

# ON Semiconductor

## Is Now

# onsemi™

To learn more about onsemi™, please visit our website at  
[www.onsemi.com](http://www.onsemi.com)

---

**onsemi** and **onsemi** and other names, marks, and brands are registered and/or common law trademarks of Semiconductor Components Industries, LLC dba "**onsemi**" or its affiliates and/or subsidiaries in the United States and/or other countries. **onsemi** owns the rights to a number of patents, trademarks, copyrights, trade secrets, and other intellectual property. A listing of **onsemi** product/patent coverage may be accessed at [www.onsemi.com/site/pdf/Patent-Marking.pdf](http://www.onsemi.com/site/pdf/Patent-Marking.pdf). **onsemi** reserves the right to make changes at any time to any products or information herein, without notice. The information herein is provided "as-is" and **onsemi** makes no warranty, representation or guarantee regarding the accuracy of the information, product features, availability, functionality, or suitability of its products for any particular purpose, nor does **onsemi** assume any liability arising out of the application or use of any product or circuit, and specifically disclaims any and all liability, including without limitation special, consequential or incidental damages. Buyer is responsible for its products and applications using **onsemi** products, including compliance with all laws, regulations and safety requirements or standards, regardless of any support or applications information provided by **onsemi**. "Typical" parameters which may be provided in **onsemi** data sheets and/or specifications can and do vary in different applications and actual performance may vary over time. All operating parameters, including "Typicals" must be validated for each customer application by customer's technical experts. **onsemi** does not convey any license under any of its intellectual property rights nor the rights of others. **onsemi** products are not designed, intended, or authorized for use as a critical component in life support systems or any FDA Class 3 medical devices or medical devices with a same or similar classification in a foreign jurisdiction or any devices intended for implantation in the human body. Should Buyer purchase or use **onsemi** products for any such unintended or unauthorized application, Buyer shall indemnify and hold **onsemi** and its officers, employees, subsidiaries, affiliates, and distributors harmless against all claims, costs, damages, and expenses, and reasonable attorney fees arising out of, directly or indirectly, any claim of personal injury or death associated with such unintended or unauthorized use, even if such claim alleges that **onsemi** was negligent regarding the design or manufacture of the part. **onsemi** is an Equal Opportunity/Affirmative Action Employer. This literature is subject to all applicable copyright laws and is not for resale in any manner. Other names and brands may be claimed as the property of others.

# STK544UC62K-E

## Intelligent Power Module (IPM) 600 V, 10 A



ON Semiconductor®

www.onsemi.com

### Overview

This Inverter IPM includes the output stage of a 3-phase inverter, pre-drive circuits, bootstrap circuits, and protection circuits in one package.

### Function

- SIP (single in-line package) of the transfer full mold structure.
- The emitter line of the each lower phase outputs to an external terminal with the option of control using 3-phase current detection with external resistors.
- Direct input of CMOS level control signals without an insulating circuit is possible.
- Protective circuits including over current and pre-drive low voltage protection are built in.
- A single power supply drive is enabled through the use of bootstrap circuits for upper IGBT gate drives.
- Built-in dead-time for shoot-thru protection.
- Internal substrate temperature is measured with an internal pulled up thermistor.

### Certification

- UL1557 (File Number : E339285)

### Specifications

#### Absolute Maximum Ratings at Tc = 25°C

Parameter	Symbol	Conditions	Ratings	Unit
Supply voltage	V <sub>CC</sub>	V+ to VRU(VRV,VRW), surge < 500 V *1	450	V
Collector-emitter voltage	V <sub>CE</sub>	V+ to U(V,W) or U(V,W) to VRU(VRV,VRW)	600	V
Output current	I <sub>o</sub>	V+, VRU,VRV,VRW, U,V,W terminal current	±10	A
		V+, VRU,VRV,VRW, U,V,W terminal current at Tc = 100°C	±6	A
Output peak current	I <sub>op</sub>	V+, VRU,VRV,VRW, U,V,W terminal current for a pulse width of 1 ms	±20	A
Pre-driver voltage	VD1,2,3,4	VB1 to U, VB2 to V, VB3 to W, V <sub>DD</sub> to V <sub>SS</sub> *2	20	V
Input signal voltage	V <sub>IN</sub>	HIN1, 2, 3, LIN1, 2, 3 terminals	-0.3 to 7	V
ITRIP terminal voltage	V <sub>ITRIP</sub>	ITRIP terminal	V <sub>SS</sub> +5	V
Maximum power dissipation	P <sub>d</sub>	IGBT per 1 channel	22	W
Junction temperature	T <sub>j</sub>	IGBT,FRD	150	°C
Storage temperature	T <sub>stg</sub>		-40 to +125	°C
Operating case temperature	T <sub>c</sub>	IPM case temperature	-40 to +100	°C
Tightening torque		Case mounting screws *3	0.9	Nm
Withstand voltage	V <sub>is</sub>	50 Hz sine wave AC 1 minute *4	2000	VRMS

Reference voltage is "V<sub>SS</sub>" terminal voltage unless otherwise specified.

\*1 : Surge voltage developed by the switching operation due to the wiring inductance between V+ and VRU(VRV,VRW) terminals.

\*2 : VD1 = VB1 to U, VD2 = VB2 to V, VD3 = VB3 to W, VD4 = V<sub>DD</sub> to V<sub>SS</sub> terminal voltage.

\*3 : Flatness of the heat-sink should be less than -50 μm to +100 μm.

\*4 : Test conditions : AC 2500 V, 1 second.

Stresses exceeding those listed in the Maximum Ratings table may damage the device. If any of these limits are exceeded, device functionality should not be assumed, damage may occur and reliability may be affected.

### ORDERING INFORMATION

See detailed ordering and shipping information on page 15 of this data sheet.

## STK544UC62K-E

### Electrical Characteristics at Tc = 25°C, VD1, VD2, VD3, VD4 = 15 V

Parameter	Symbol	Conditions	Test circuit	Ratings			Unit
				min	typ	max	
<b>Power output section</b>							
Collector-emitter cut-off current	I <sub>CE</sub>	V <sub>CE</sub> = 600 V	Fig.1	-	-	0.1	mA
Bootstrap diode reverse current	I <sub>R(BD)</sub>	V <sub>R(BD)</sub> = 600 V		-	-	0.1	mA
Collector to emitter saturation voltage	V <sub>CE(SAT)</sub>	I <sub>o</sub> = 10 A, T <sub>j</sub> = 25°C	Fig.2	-	1.4	2.3	V
		I <sub>o</sub> = 5 A, T <sub>j</sub> = 100°C		-	1.3	-	
Diode forward voltage	V <sub>F</sub>	I <sub>o</sub> = 10 A, T <sub>j</sub> = 25°C	Fig.3	-	1.3	2.2	V
		I <sub>o</sub> = 5 A, T <sub>j</sub> = 100°C		-	1.2	-	
Bootstrap diode forward voltage	V <sub>F(BD)</sub>	I <sub>F</sub> = 0.1 A	-	-	2.0	-	V
Bootstrap circuit resistance	R <sub>BC</sub>	Resistor value for common boot charge line	-	-	2	-	Ω
	R <sub>BS</sub>	Resistor values for separate boot charge lines	-	-	10	-	
Junction to case thermal resistance	θ <sub>j-c(T)</sub>	IGBT	-	-	4.5	5.5	°C/W
	θ <sub>j-c(D)</sub>	FRD		-	-	5.5	
Thermal resistance case to sink	R <sub>th(c-s)</sub>	1W/mK thermal conductivity *1	-	-	0.1	-	
<b>Protection section</b>							
FAULT clearance delay time	FLTCLR	Form time fault condition clears	-	6	9	12	ms
Switching time	t <sub>ON</sub>	I <sub>o</sub> = 10 A	Fig.5	-	0.48	-	μs
	t <sub>OFF</sub>	Inductive load		-	0.54	-	

Reference voltage is "V<sub>SS</sub>" terminal voltage unless otherwise specified.

\*1 : At 100 μm thickness of the thermal grease.

Product parametric performance is indicated in the Electrical Characteristics for the listed test conditions, unless otherwise noted. Product performance may not be indicated by the Electrical Characteristics if operated under different conditions.

### Electrical Characteristics Driver Function at Tc = 25°C

Parameter	Symbol	Test circuit	Ratings			Unit
			min	typ	max	
<b>Supply section</b>						
V <sub>DD</sub> and V <sub>BS</sub> supply undervoltage protection reset	V <sub>DDUV+</sub>	-	10.5	11.1	11.7	V
	V <sub>BSUV+</sub>					
V <sub>DD</sub> and V <sub>BS</sub> supply undervoltage protection set	V <sub>DDUV-</sub>	-	10.3	10.9	11.5	V
	V <sub>BSUV-</sub>					
V <sub>DD</sub> and V <sub>BS</sub> supply undervoltage hysteresis	V <sub>DDUVH</sub>	-	0.14	0.2	-	V
	V <sub>BSUVH</sub>					
Quiescent V <sub>DD</sub> supply current	I <sub>QDD</sub>	Fig.4	-	2.0	4.0	mA
Quiescent V <sub>BS</sub> supply current	I <sub>QBS</sub>		-	0.08	0.4	mA
<b>Input section</b>						
Logic low input voltage	V <sub>INL</sub>	-	-	-	0.8	V
Logic high input voltage	V <sub>INH</sub>	-	2.5	-	-	V
Logic 0 input leakage current	I <sub>IN+</sub>	-	76	118	160	μA
Logic 1 input leakage current	I <sub>IN-</sub>	-	97	150	203	μA
ITRIP threshold voltage (OUT = LO or OUT = HI)	V <sub>ITRIP</sub>	-	3.67	4.17	4.67	V
<b>Dynamic section</b>						
Dead time (Internal dead time injected by driver)	DT	-	220	300	380	ns
ITRIP to shutdown propagation delay	t <sub>ITRIP</sub>	-	1.0	1.2	1.4	μs
ITRIP blanking time	t <sub>ITRPBL</sub>	-	-	0.9	-	μs

Reference voltage is "V<sub>SS</sub>" terminal voltage unless otherwise specified.

## STK544UC62K-E

### Switching Characteristics at Tc = 25°C, VD1, VD2, VD3, VD4 = 15 V

Parameter	Symbol	Conditions	Ratings			Unit
			min	typ	max	
Turn-on switching loss	Eon	I <sub>C</sub> = 5 A, V <sub>+</sub> = 400 V V <sub>DD</sub> = 15 V, L = 3.9 mH, Tc = 25°C	-	195	-	μJ
Turn-off switching loss	Eoff		-	122	-	μJ
Total switching loss	Etot		-	317	-	μJ
Turn-on switching loss	Eon	I <sub>C</sub> = 5 A, V <sub>+</sub> = 400 V, V <sub>DD</sub> = 15 V, L = 3.9 mH, Tc = 100°C	-	224	-	μJ
Turn-off switching loss	Eoff		-	186	-	μJ
Total switching loss	Etot		-	410	-	μJ
Diode reverse recovery time	trr	I <sub>F</sub> = 5 A, V <sub>+</sub> = 400 V, V <sub>DD</sub> = 15 V, L = 3.9 mH, Tc = 100°C	-	70	-	ns
Reverse bias safe operating area	RBSOA	I <sub>o</sub> = 20 A, V <sub>CE</sub> = 450 V	FULL SQUARE			-
Short circuit safe operating area	SCSOA	V <sub>CE</sub> = 400 V	4	-	-	μs

V<sub>DD</sub> = V<sub>B1</sub> = V<sub>B2</sub> = V<sub>B3</sub> = 15 V, V<sub>SS</sub> = V<sub>S1</sub> = V<sub>S2</sub> = V<sub>S3</sub> = 0 V, outputs loaded with 1 nF, all voltage are referenced to V<sub>SS</sub>; unless otherwise noted.

### Internal NTC-Thermistor Characteristics

Parameter		Conditions	Typ.	Unit
R25	Resistance	Tc = 25°C	100 ±3%	kΩ
R125	Resistance	Tc = 125°C	2.522 ±3%	kΩ
B	B-Constant (25 to 50°C)	$R_2 = R_1 e^{[B(1/T_2 - 1/T_1)]}$	4250 ±1%	K
Temperature range		-	-40 to +125	°C
Typ. Dissipation constant		Tc=25°C	1	mW/°C

### Notes

- The pre-drive power supply low voltage protection has approximately 200 mV of hysteresis and operates as follows.
  - Upper side : The gate is turned off and will return to regular operation when recovering to the normal voltage, but the latch will continue till the input signal will turn 'high'.
  - Lower side : The gate is turned off and will automatically reset when recovering to normal voltage. It does not depend on input signal voltage.
- When assembling the IPM on the heat sink the tightening torque range is 0.6 Nm to 0.9 Nm.
- The pre-drive low voltage protection protects the device when the pre-drive supply voltage falls due to an operating malfunction.
- When use the over-current protection with external shunt resistor, please set the current protection level to be equal to or less than the rating of output peak current (I<sub>op</sub>).

# STK544UC62K-E

## Equivalent Block Diagram

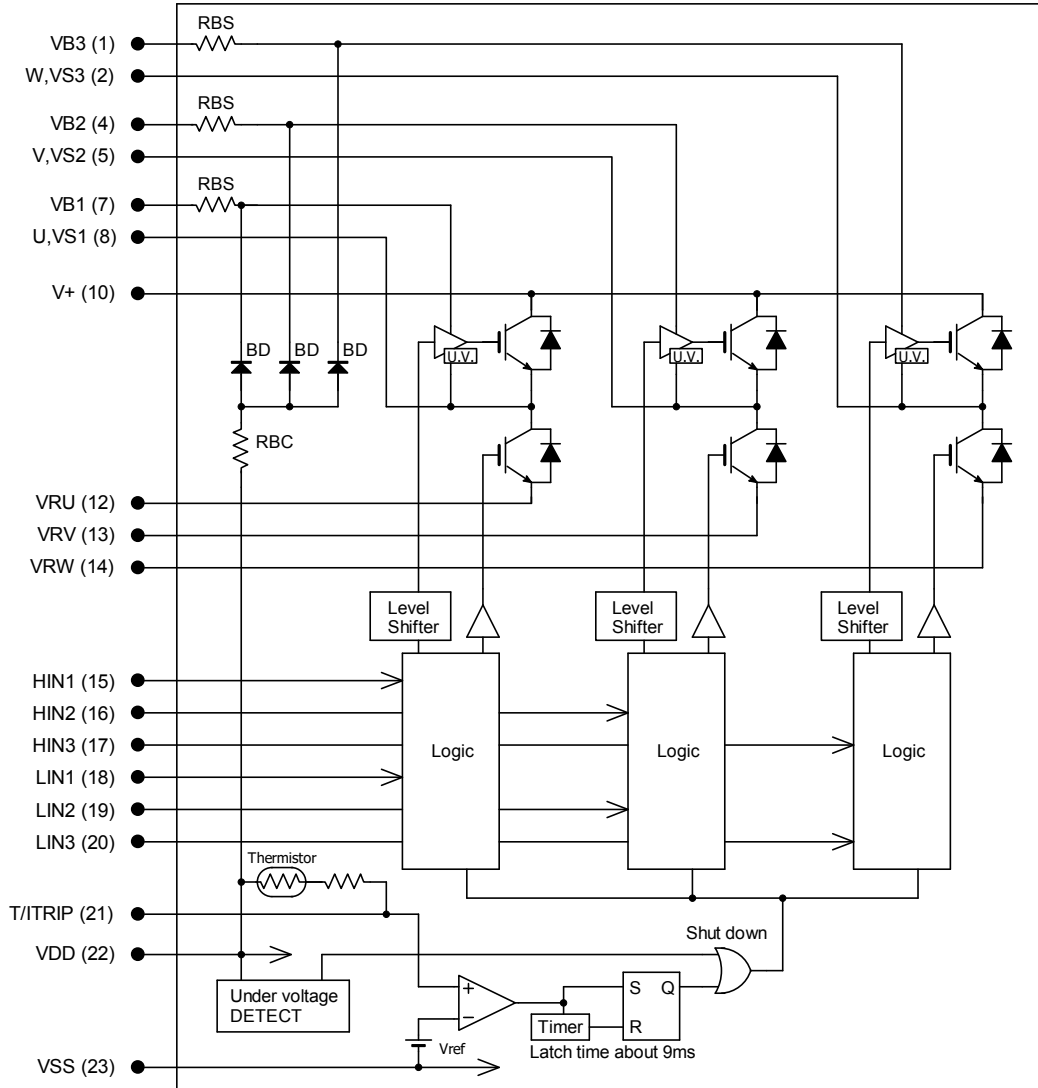

## Module Pin-Out Description

Pin	Name	Description
1	VB3	High Side Floating Supply Voltage 3
2	W, VS3	Output 3, High Side Floating Supply Offset Voltage 3
3	-	Without pin
4	VB2	High Side Floating Supply Voltage 2
5	V, VS2	Output 2, High Side Floating Supply Offset Voltage 2
6	-	Without pin
7	VB1	High Side Floating Supply Voltage 1
8	U, VS1	Output 1, High Side Floating Supply Offset Voltage 1
9	-	Without pin
10	V+	Positive Bus Input Voltage
11	-	Without pin
-	-	-

Pin	Name	Description
12	VRU	Low Side Emitter Connection – Phase 1
13	VRV	Low Side Emitter Connection – Phase 2
14	VRW	Low Side Emitter Connection – Phase 3
15	HIN1	Logic Input High Side Gate Driver – Phase 1
16	HIN2	Logic Input High Side Gate Driver – Phase 2
17	HIN3	Logic Input High Side Gate Driver – Phase 3
18	LIN1	Logic Input Low Side Gate Driver – Phase 1
19	LIN2	Logic Input Low Side Gate Driver – Phase 2
20	LIN3	Logic Input Low Side Gate Driver – Phase 3
21	T/Itrip	Temperature Monitor and Shut-down Pin
22	VDD	+15 V Main Supply
23	VSS	Negative Main Supply

# STK544UC62K-E

## Test Circuit

The tested phase U+ shows the upper side of the U phase and U- shows the lower side of the U phase.

### ■ $I_{CE} / I_R(BD)$

	U+	V+	W+	U-	V-	W-
M	10	10	10	8	5	2
N	8	5	2	12	13	14

	U(BD)	V(BD)	W(BD)
M	7	4	1
N	23	23	23

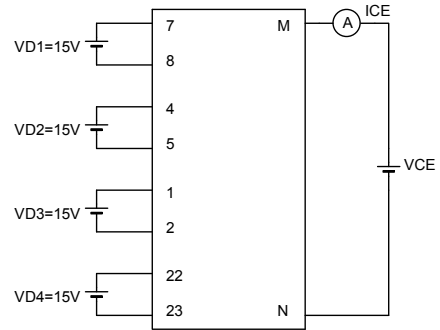

Fig. 1

### ■ $V_{CE(SAT)}$ (test by pulse)

	U+	V+	W+	U-	V-	W-
M	10	10	10	8	5	2
N	8	5	2	12	13	14
m	15	16	17	18	19	20

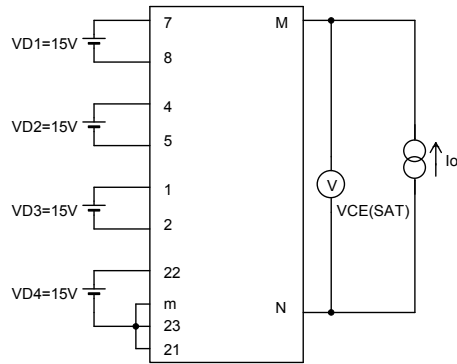

Fig. 2

### ■ $V_F$ (test by pulse)

	U+	V+	W+	U-	V-	W-
M	10	10	10	8	5	2
N	8	5	2	12	13	14

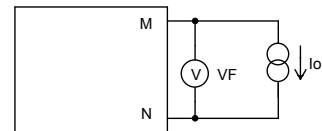

Fig. 3

### ■ $I_D$

	VD1	VD2	VD3	VD4
M	7	4	1	22
N	8	5	2	23

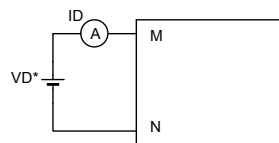

Fig. 4

# STK544UC62K-E

- Switching time (The circuit is a representative example of the lower side U phase.)

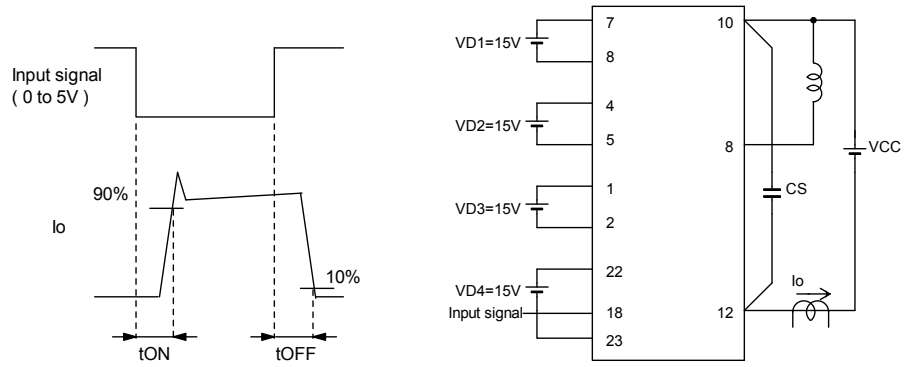

Fig. 5

- RB-SOA (The circuit is a representative example of the lower side U phase.)

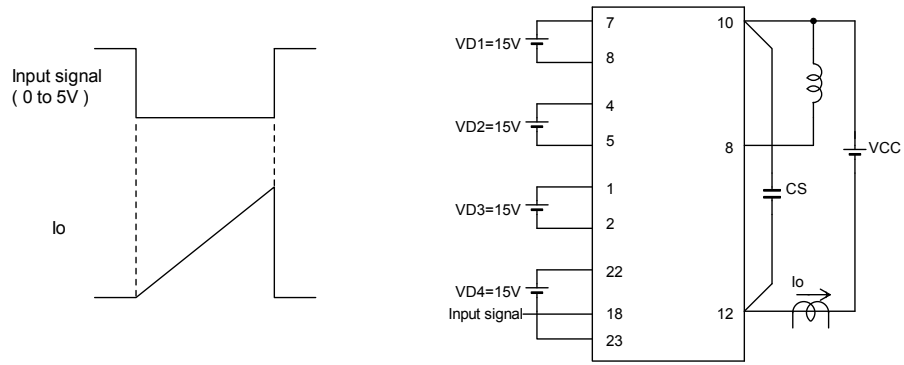

Fig. 6

# STK544UC62K-E

## Input / Output Timing Diagram

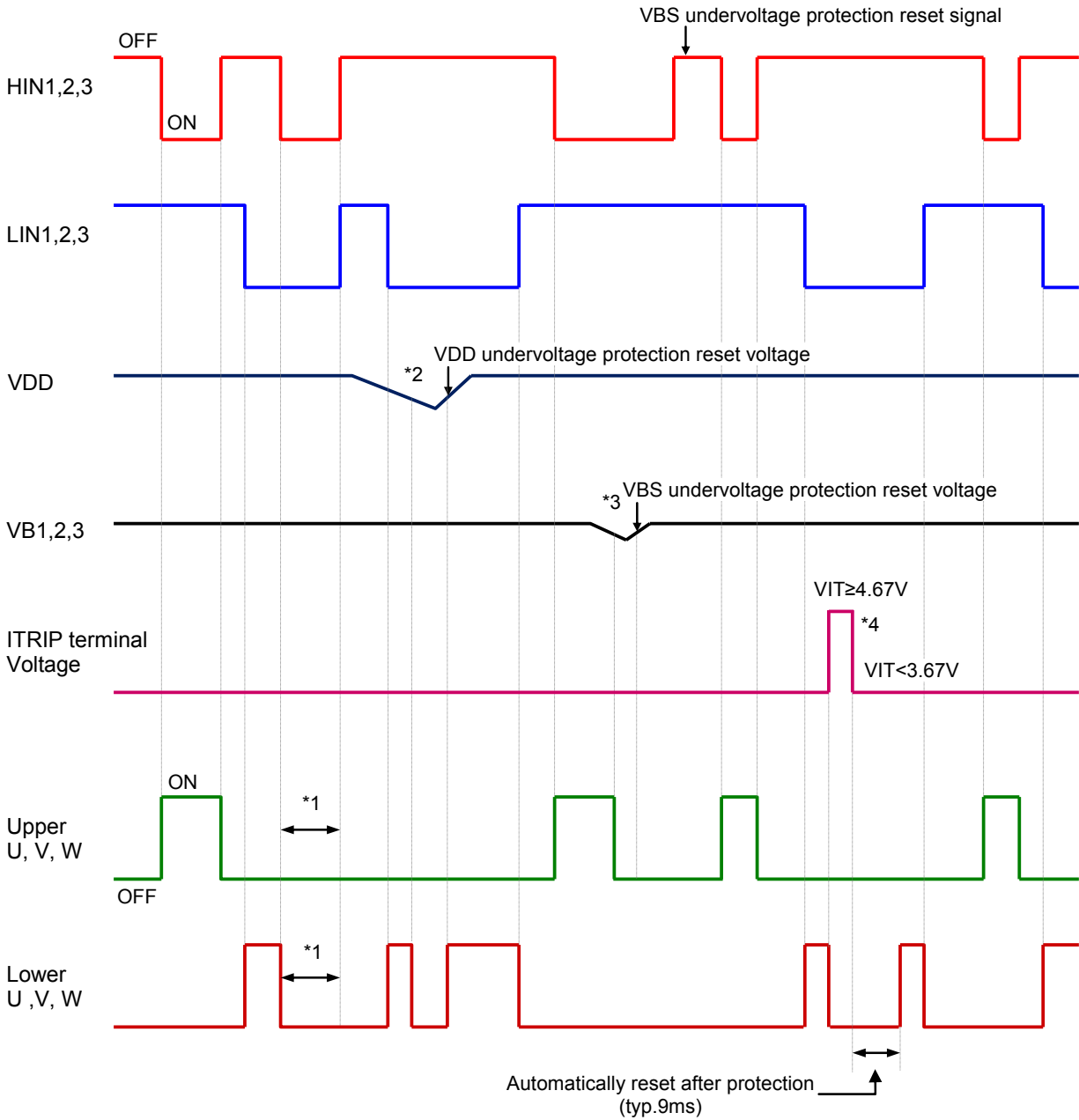

Fig. 7

### Notes

- \*1 : Shows the prevention of shoot-thru via control logic, however, more dead time must be added to account for switching delay externally.
- \*2 : When  $V_{DD}$  decreases all gate output signals will go low and cut off all 6 IGBT outputs. When  $V_{DD}$  rises the operation will resume immediately.
- \*3 : When the upper side voltage at VB1, VB2 and VB3 drops only the corresponding upper side output is turned off. The outputs return to normal operation immediately after the upper side gate voltage rises.
- \*4 : When  $V_{ITRIP}$  exceeds threshold all IGBT's are turned off and normal operation resumes 9 ms (typ) after over current condition is removed.



Logic level table

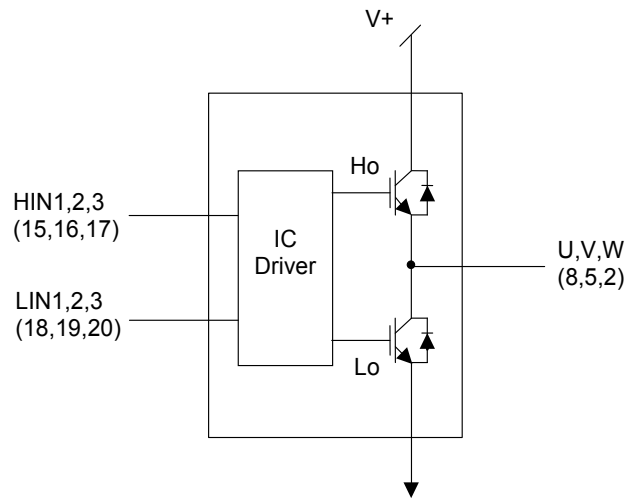

Itrip	HIN1,2,3	LIN1,2,3	U,V,W
0	0	1	V+
0	1	0	0
0	1	1	X
1	X	X	X

Fig. 8

# STK544UC62K-E

## Sample Application Circuit

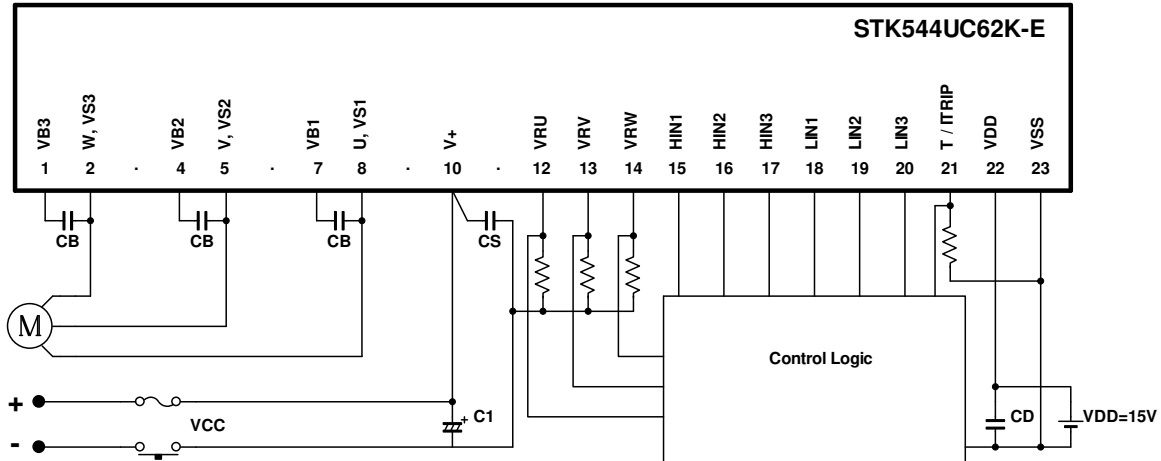

## Recommended Operating Conditions at Tc = 25°C

Item	Symbol	Conditions	Ratings			Unit
			min	typ	max	
Supply voltage	V <sub>CC</sub>	Between V+ to VRU(VRV,VRW)	0	280	450	V
Pre-driver supply voltage	VD1,2,3	Between VB1 to U,VB2 to V,VB3 to W	12.5	15	17.5	V
	VD4	Between V <sub>DD</sub> to V <sub>SS</sub> *1	13.5	15	16.5	
ON-state input voltage	V <sub>IN(ON)</sub>	HIN1,HIN2,HIN3,LIN1,LIN2,LIN3	0	-	0.3	V
OFF-state input voltage	V <sub>IN(OFF)</sub>	terminal	3.0	-	5.0	
PWM frequency	f <sub>PWM</sub>	-	1	-	20	kHz
Dead time	DT	Turn-off to turn-on (External)	0.5	-	-	μs
Mounting torque	-	'M3' type screw	0.6	-	0.9	Nm

\*1 : Pre-drive power supply (VD4 = 15 ± 1.5 V) must be have the capacity of I<sub>o</sub> = 20 mA (DC), 0.5 A (Peak).

Functional operation above the stresses listed in the Recommended Operating Ranges is not implied. Extended exposure to stresses beyond the Recommended Operating Ranges limits may affect device reliability.

## Usage Precaution

1. This IPM includes internal bootstrap diode and resistor. By adding a capacitor CB, a single high side drive voltage is generated; each phase requires an individual bootstrap capacitor. The recommended value of CB is in the range of 1 to 47 μF, however, this value needs to be verified prior to production. When not using the bootstrap circuit, each upper side pre-drive power supply requires an external independent power supply.
2. It is essential that wiring length between terminals in the snubber circuit be kept as short as possible to reduce the effect of surge voltages. Recommended value of CS is in the range of 0.1 to 10 μF.
3. VRU, VRV, and VRW terminals are direct outputs of the emitter line of the each lower phase IGBT and can be used to monitor each phase's or collective current with external resistors. IF current is not monitored, each resistor should be short-circuited.
4. Disconnection of terminals U, V, or W during normal motor operation will cause damage to IPM, use caution with this connection.
5. Zener diode with 10 V is connected with the inside of the signal input terminal. When inputting voltage which exceeds 5 V, connect resistor between the side of the power and the signal input terminal, for the input current of the signal input terminal become equal to or less than 0.5 mA. This resistor is effective with the noise absorption of the signal terminal, too.
6. A fuse on V<sub>CC</sub> is recommended.
7. Inside the IPM, a thermistor used as the temperature monitor is connected between V<sub>DD</sub> terminal and T/ITRIP terminal, therefore, an external pull down resistor connected between the T/ITRIP terminal and V<sub>SS</sub> terminal should be used. The temperature monitor example application is as follows, please refer the Fig.10, Fig.11, and Fig.12 below.
8. All data shown implements an example of the application circuit but does not guarantee a design for the mass production.

# STK544UC62K-E

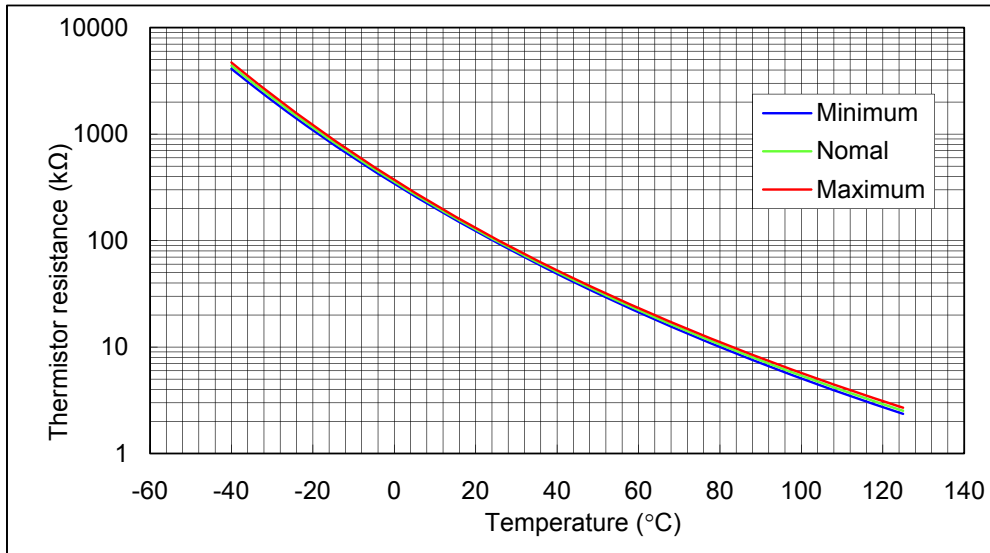

Fig. 10 Variation of thermistor resistance with temperature

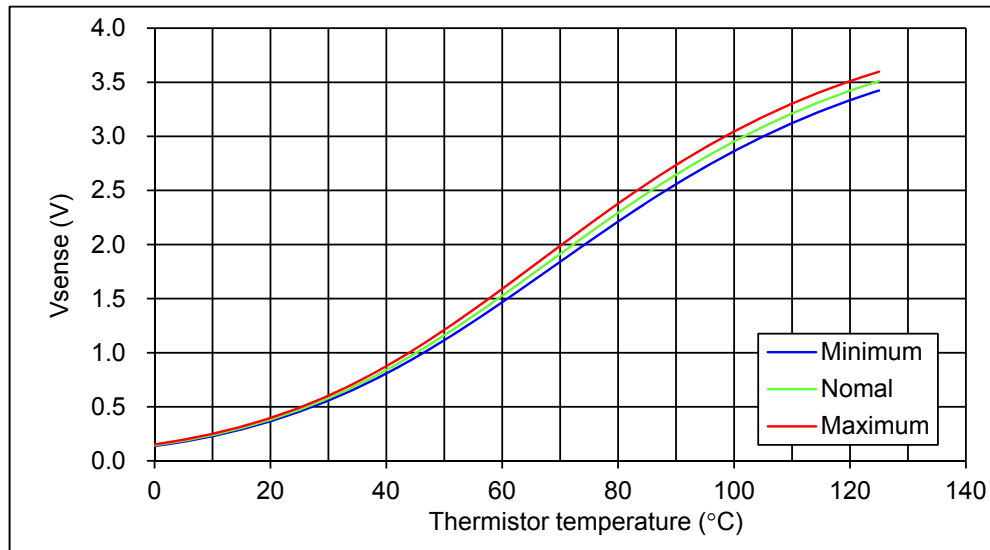

Fig. 11 Variation of temperature sense voltage with thermistor temperature by using external bias resistance of 4.3 kΩ ±1% and V<sub>DD</sub> = 15 V

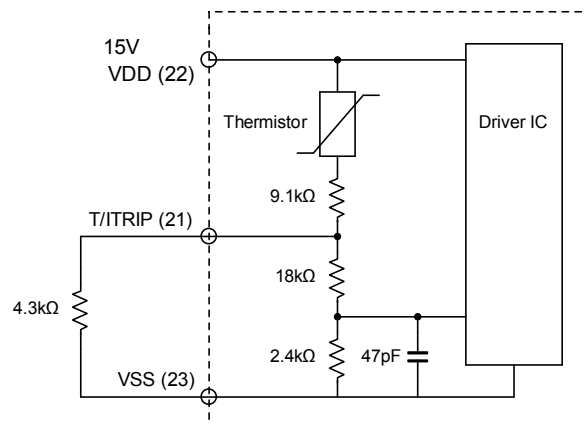

Fig. 12 Sample application circuit for temperature monitoring

# STK544UC62K-E

## The characteristic of PWM switching frequency

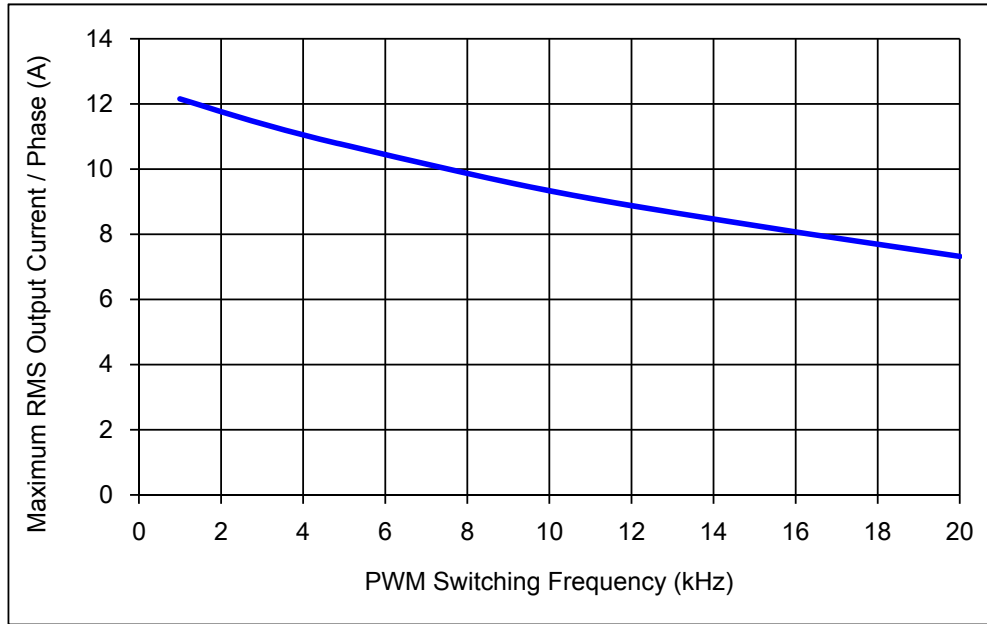

Fig. 13 Maximum sinusoidal phase current as function of switching frequency  
at  $T_c = 100^\circ\text{C}$ ,  $V_{CC} = 400\text{ V}$

Switching waveform

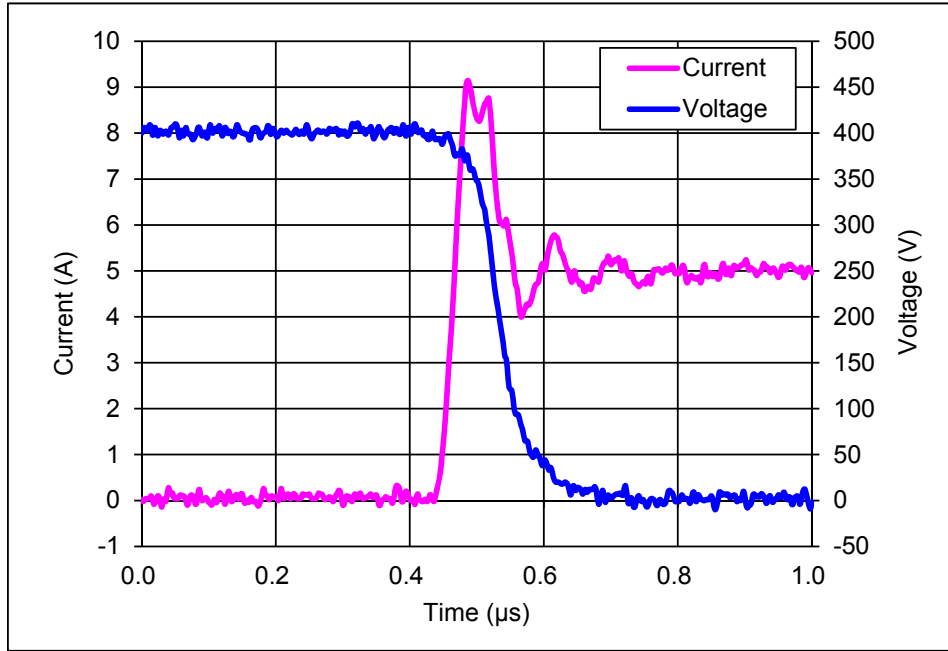

Fig. 14 IGBT Turn-on. Typical turn-on waveform at  $T_c = 100^\circ\text{C}$ ,  $V_{CC} = 400\text{ V}$

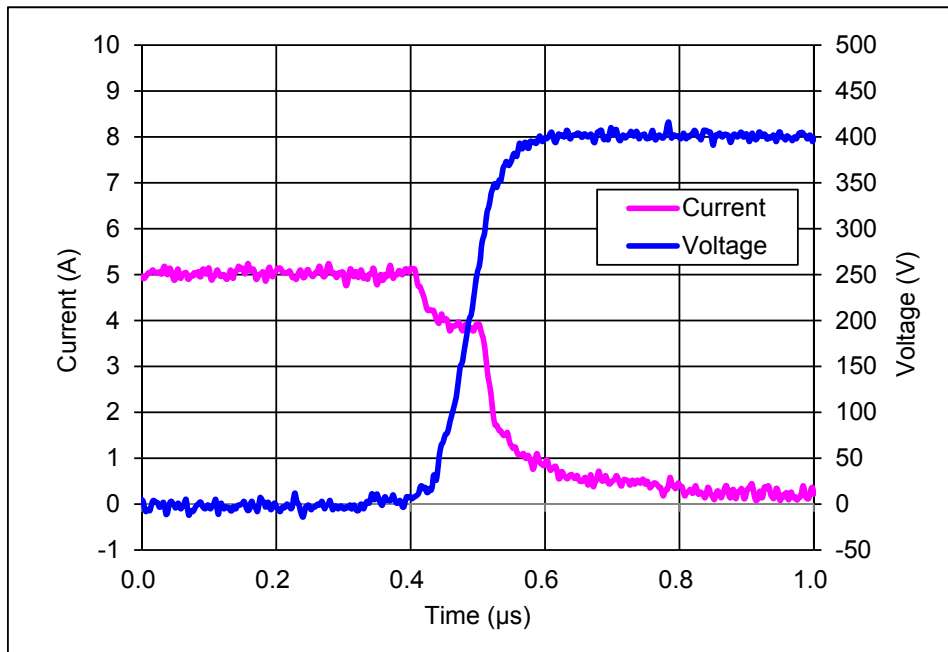

Fig. 15 IGBT Turn-off. Typical turn-off waveform at  $T_c = 100^\circ\text{C}$ ,  $V_{CC} = 400\text{ V}$

**CB capacitor value calculation for bootstrap circuit**

**Calculate conditions**

Parameter	Symbol	Value	Unit
Upper side power supply	VBS	15	V
Total gate charge of output power IGBT at 15 V	QG	89	nC
Upper limit power supply low voltage protection	UVLO	12	V
Upper side power dissipation	IDMAX	95	μA
ON time required for CB voltage to fall from 15 V to UVLO	TONMAX	-	S

**Capacitance calculation formula**

Thus, the following formula are true  
 $VBS \times CB - QG - IDMAX \times TONMAX = UVLO \times CB$   
 therefore,  
 $CB = (QG + IDMAX \times TONMAX) / (VBS - UVLO)$

The relationship between TONMAX and CB becomes as follows. CB is recommended to be approximately 3 times the value calculated above. The recommended value of CB is in the range of 1 to 47 μF, however, this value needs to be verified prior to production.

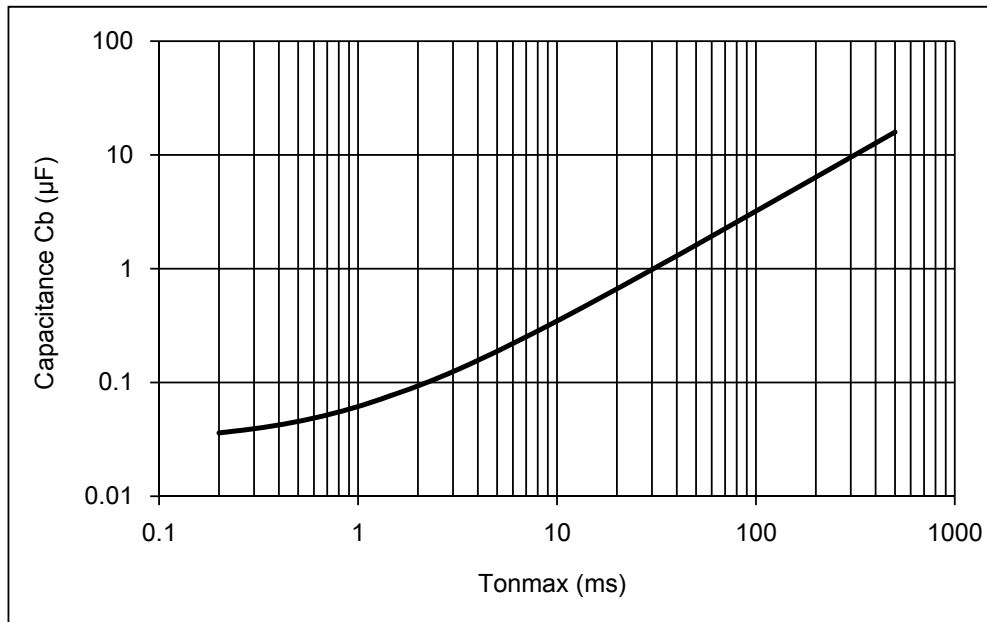

Fig. 16 TONMAX vs CB characteristic

# STK544UC62K-E

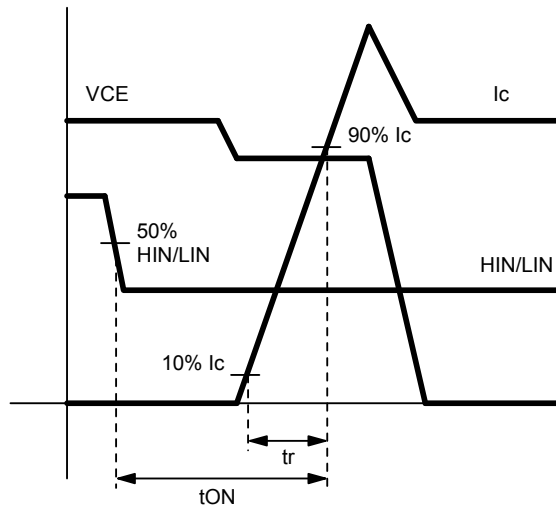

Fig. 17 Input to output propagation turn-on delay time

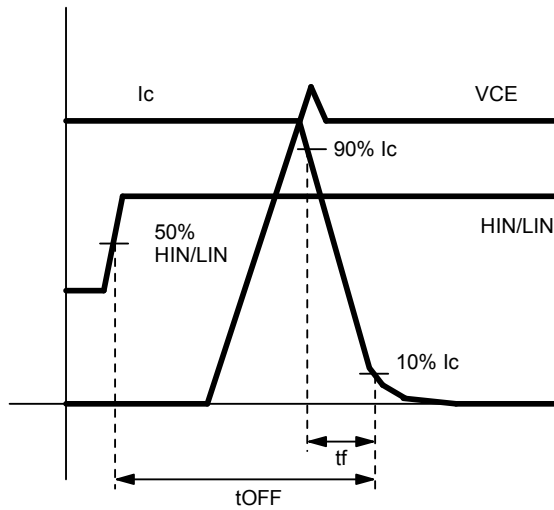

Fig. 18 Input to output propagation turn-off delay time

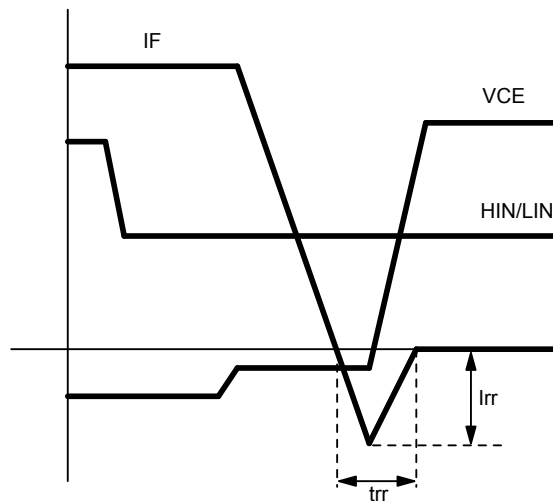
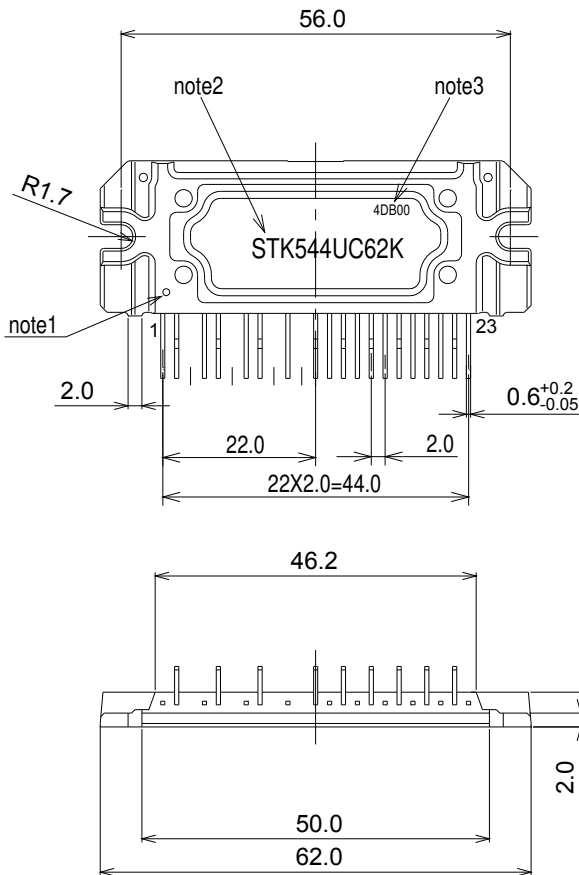

Fig. 19 Diode reverse recovery

# STK544UC62K-E

## PACKAGE DIMENSIONS

unit : mm



missing pin :3,6,9,11

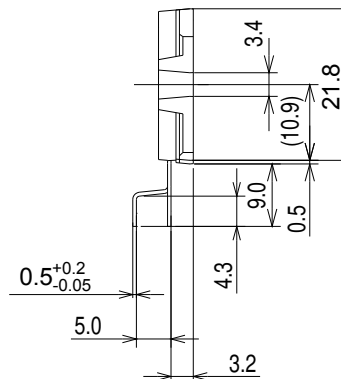

- note1 : Mark for No.1 pin identification.
- note2 : The form of a character in this drawing differs from that of IPM.
- note3 : This indicates the lot code.  
The form of a character in this drawing differs from that of IPM.

The tolerances of length are +/- 0.5 mm unless otherwise specified.

## ORDERING INFORMATION

Device	Package	Shipping (Qty / Packing)
STK544UC62K-E	SIP23 (Pb-Free)	8 / Tube

ON Semiconductor and the ON Semiconductor logo are trademarks of Semiconductor Components Industries, LLC dba ON Semiconductor or its subsidiaries in the United States and/or other countries. ON Semiconductor owns the rights to a number of patents, trademarks, copyrights, trade secrets, and other intellectual property. A listing of ON Semiconductor's product/patent coverage may be accessed at [www.onsemi.com/site/pdf/Patent-Marking.pdf](http://www.onsemi.com/site/pdf/Patent-Marking.pdf). ON Semiconductor reserves the right to make changes without further notice to any products herein. ON Semiconductor makes no warranty, representation or guarantee regarding the suitability of its products for any particular purpose, nor does ON Semiconductor assume any liability arising out of the application or use of any product or circuit, and specifically disclaims any and all liability, including without limitation special, consequential or incidental damages. Buyer is responsible for its products and applications using ON Semiconductor products, including compliance with all laws, regulations and safety requirements or standards, regardless of any support or applications information provided by ON Semiconductor. "Typical" parameters which may be provided in ON Semiconductor data sheets and/or specifications can and do vary in different applications and actual performance may vary over time. All operating parameters, including "Typicals" must be validated for each customer application by customer's technical experts. ON Semiconductor does not convey any license under its patent rights nor the rights of others. ON Semiconductor products are not designed, intended, or authorized for use as a critical component in life support systems or any FDA Class 3 medical devices or medical devices with a same or similar classification in a foreign jurisdiction or any devices intended for implantation in the human body. Should Buyer purchase or use ON Semiconductor products for any such unintended or unauthorized application, Buyer shall indemnify and hold ON Semiconductor and its officers, employees, subsidiaries, affiliates, and distributors harmless against all claims, costs, damages, and expenses, and reasonable attorney fees arising out of, directly or indirectly, any claim of personal injury or death associated with such unintended or unauthorized use, even if such claim alleges that ON Semiconductor was negligent regarding the design or manufacture of the part. ON Semiconductor is an Equal Opportunity/Affirmative Action Employer. This literature is subject to all applicable copyright laws and is not for resale in any manner.