

# STB33N65M2, STF33N65M2, STP33N65M2, STI33N65M2

N-channel 650 V, 0.117  $\Omega$  typ., 24 A MDmesh™ M2  
Power MOSFETs in D<sup>2</sup>PAK, TO-220FP, TO-220 and I<sup>2</sup>PAK packages

Datasheet - production data

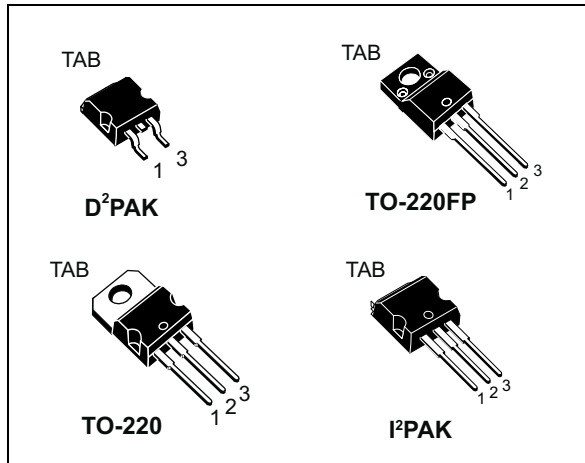
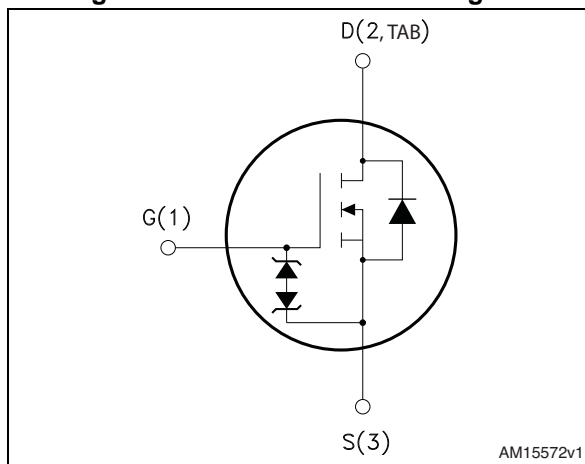

Figure 1. Internal schematic diagram



## Features

Order codes	V <sub>DS</sub>	R <sub>DS(on)</sub> max	I <sub>D</sub>
STB33N65M2	650 V	0.14 $\Omega$	24 A
STF33N65M2			
STP33N65M2			
STI33N65M2			

- Extremely low gate charge
- Excellent output capacitance (C<sub>oss</sub>) profile
- 100% avalanche tested
- Zener-protected

## Applications

- Switching applications

## Description

These devices are N-channel Power MOSFETs developed using MDmesh™ M2 technology. Thanks to their strip layout and improved vertical structure, the devices exhibit low on-resistance and optimized switching characteristics, rendering them suitable for the most demanding high efficiency converters.

Table 1. Device summary

Order codes	Marking	Package	Packaging
STB33N65M2	33N65M2	D <sup>2</sup> PAK	Tape and reel
STF33N65M2		TO-220FP	Tube
STP33N65M2		TO-220	
STI33N65M2		I <sup>2</sup> PAK	

# Contents

- 1      Electrical ratings ..... 3**
- 2      Electrical characteristics ..... 4**
  - 2.1    Electrical characteristics (curves) ..... 6
- 3      Test circuits ..... 9**
- 4      Package mechanical data ..... 10**
  - 4.1    D<sup>2</sup>PAK, STB33N65M2 ..... 10
  - 4.2    TO-220FP, STF33N65M2 ..... 13
  - 4.3    TO-220, STP33N65M2 ..... 15
  - 4.4    I<sup>2</sup>PAK, STI33N65M2 ..... 17
- 5      Packaging mechanical data ..... 19**
- 6      Revision history ..... 22**

# 1 Electrical ratings

**Table 2. Absolute maximum ratings**

Symbol	Parameter	Value		Unit
		D <sup>2</sup> PAK, TO-220, I <sup>2</sup> PAK	TO-220FP	
V <sub>GS</sub>	Gate-source voltage	± 25		V
I <sub>D</sub>	Drain current (continuous) at T <sub>C</sub> = 25 °C	24	24 <sup>(1)</sup>	A
I <sub>D</sub>	Drain current (continuous) at T <sub>C</sub> = 100 °C	15	15 <sup>(1)</sup>	A
I <sub>DM</sub> <sup>(2)</sup>	Drain current (pulsed)	96		A
P <sub>TOT</sub>	Total dissipation at T <sub>C</sub> = 25 °C	190	34	W
V <sub>ISO</sub>	Insulation withstand voltage (RMS) from all three leads to external heat sink (t=1 s; T <sub>C</sub> =25 °C)		2500	V
dv/dt <sup>(3)</sup>	Peak diode recovery voltage slope	15		V/ns
dv/dt <sup>(4)</sup>	MOSFET dv/dt ruggedness	50		
T <sub>stg</sub>	Storage temperature	- 55 to 150		°C
T <sub>j</sub>	Max. operating junction temperature	150		

1. Current limited by package.
2. Pulse width limited by safe operating area.
3. I<sub>SD</sub> ≤ 24 A, di/dt ≤ 400 A/μs; V<sub>DS peak</sub> < V<sub>(BR)DSS</sub>; V<sub>DD</sub>=400 V
4. V<sub>DS</sub> ≤ 520 V

**Table 3. Thermal data**

Symbol	Parameter	Value				Unit
		D <sup>2</sup> PAK	TO-220FP	TO-220	I <sup>2</sup> PAK	
R <sub>thj-case</sub>	Thermal resistance junction-case max	0.66	3.68	0.66		°C/W
R <sub>thj-pcb</sub> <sup>(1)</sup>	Thermal resistance junction-pcb max	30				°C/W
R <sub>thj-amb</sub>	Thermal resistance junction-ambient max		62.5			°C/W

1. When mounted on 1 inch<sup>2</sup> FR-4, 2 Oz copper board

**Table 4. Avalanche characteristics**

Symbol	Parameter	Value	Unit
I <sub>AR</sub>	Avalanche current, repetitive or not repetitive (pulse width limited by T <sub>jmax</sub> )	2.5	A
E <sub>AS</sub>	Single pulse avalanche energy (starting T <sub>j</sub> =25°C, I <sub>D</sub> = I <sub>AR</sub> ; V <sub>DD</sub> =50 V)	780	mJ

## 2 Electrical characteristics

( $T_C = 25\text{ °C}$  unless otherwise specified)

**Table 5. On /off states**

Symbol	Parameter	Test conditions	Min.	Typ.	Max.	Unit
$V_{(BR)DSS}$	Drain-source breakdown voltage	$V_{GS} = 0, I_D = 1\text{ mA}$	650			V
$I_{DSS}$	Zero gate voltage drain current	$V_{GS} = 0, V_{DS} = 650\text{ V}$			1	$\mu\text{A}$
		$V_{GS} = 0, V_{DS} = 650\text{ V}, T_C = 125\text{ °C}$			100	$\mu\text{A}$
$I_{GSS}$	Gate-body leakage current	$V_{DS} = 0, V_{GS} = \pm 25\text{ V}$			$\pm 10$	$\mu\text{A}$
$V_{GS(th)}$	Gate threshold voltage	$V_{DS} = V_{GS}, I_D = 250\text{ }\mu\text{A}$	2	3	4	V
$R_{DS(on)}$	Static drain-source on-resistance	$V_{GS} = 10\text{ V}, I_D = 12\text{ A}$		0.117	0.14	$\Omega$

**Table 6. Dynamic**

Symbol	Parameter	Test conditions	Min.	Typ.	Max.	Unit
$C_{iss}$	Input capacitance	$V_{DS} = 100\text{ V}, f = 1\text{ MHz}, V_{GS} = 0\text{ V}$	-	1790	-	pF
$C_{oss}$	Output capacitance		-	75	-	pF
$C_{riss}$	Reverse transfer capacitance		-	2	-	pF
$C_{oss\text{ eq}}^{(1)}$	Equivalent output capacitance	$V_{GS} = 0\text{ V}, V_{DS} = 0\text{ to }520\text{ V}$	-	380	-	pF
$R_G$	Intrinsic gate resistance	$f = 1\text{ MHz open drain}$	-	5	-	$\Omega$
$Q_g$	Total gate charge	$V_{DD} = 520\text{ V}, I_D = 24\text{ A}, V_{GS} = 10\text{ V}$ (see <a href="#">Figure 17</a> )	-	41.5	-	nC
$Q_{gs}$	Gate-source charge		-	6.8	-	nC
$Q_{gd}$	Gate-drain charge		-	18	-	nC

1.  $C_{oss\text{ eq}}$  is defined as a constant equivalent capacitance giving the same charging time as  $C_{oss}$  when  $V_{DS}$  increases from 0 to 80%  $V_{DSS}$

**Table 7. Switching times**

Symbol	Parameter	Test conditions	Min.	Typ.	Max.	Unit
$t_{d(on)}$	Turn-on delay time	$V_{DD} = 325\text{ V}, I_D = 12\text{ A}, R_G = 4.7\text{ }\Omega, V_{GS} = 10\text{ V}$ (see <a href="#">Figure 16</a> and <a href="#">Figure 21</a> )	-	13.5	-	ns
$t_r$	Rise time		-	11.5	-	ns
$t_{d(off)}$	Turn-off delay time		-	72.5	-	ns
$t_f$	Fall time		-	9	-	ns

Table 8. Source drain diode

Symbol	Parameter	Test conditions	Min.	Typ.	Max.	Unit
$I_{SD}$	Source-drain current		-		24	A
$I_{SDM}^{(1)}$	Source-drain current (pulsed)		-		96	A
$V_{SD}^{(2)}$	Forward on voltage	$V_{GS} = 0\text{ V}$ , $I_{SD} = 24\text{ A}$	-		1.6	V
$t_{rr}$	Reverse recovery time	$I_{SD} = 24\text{ A}$ , $di/dt = 100\text{ A}/\mu\text{s}$ $V_{DD} = 60\text{ V}$ (see <a href="#">Figure 18</a> )	-	426		ns
$Q_{rr}$	Reverse recovery charge		-	7		$\mu\text{C}$
$I_{RRM}$	Reverse recovery current		-	33.5		A
$t_{rr}$	Reverse recovery time	$I_{SD} = 24\text{ A}$ , $di/dt = 100\text{ A}/\mu\text{s}$ $V_{DD} = 60\text{ V}$ , $T_j = 150\text{ }^\circ\text{C}$ (see <a href="#">Figure 18</a> )	-	544		ns
$Q_{rr}$	Reverse recovery charge		-	10		$\mu\text{C}$
$I_{RRM}$	Reverse recovery current		-	36.5		A

1. Pulse width limited by safe operating area.
2. Pulsed: pulse duration = 300  $\mu\text{s}$ , duty cycle 1.5%

## 2.1 Electrical characteristics (curves)

Figure 2. Safe operating area for TO-220, D<sup>2</sup>PAK and I<sup>2</sup>PAK

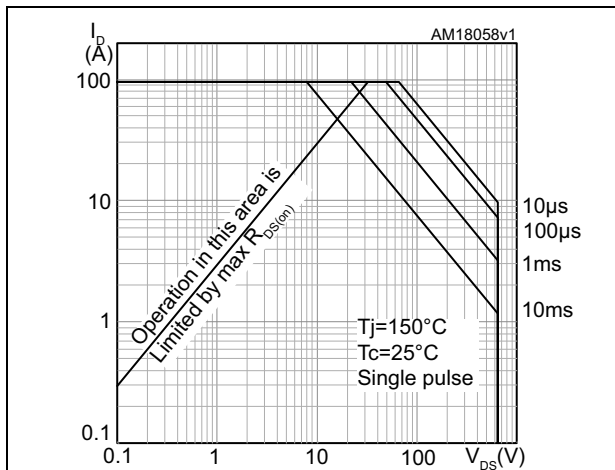

Figure 3. Thermal impedance for TO-220, D<sup>2</sup>PAK and I<sup>2</sup>PAK

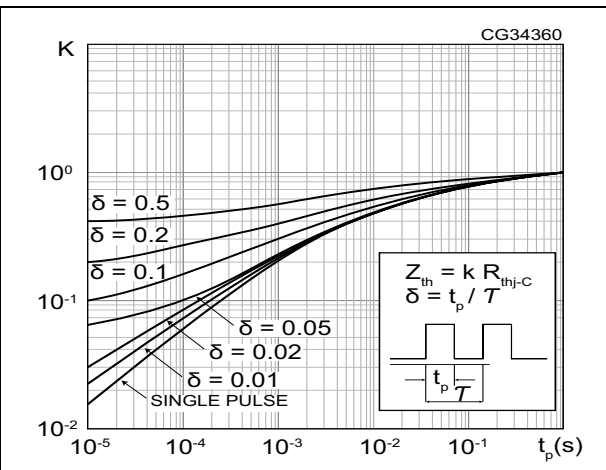

Figure 4. Safe operating area for TO-220FP

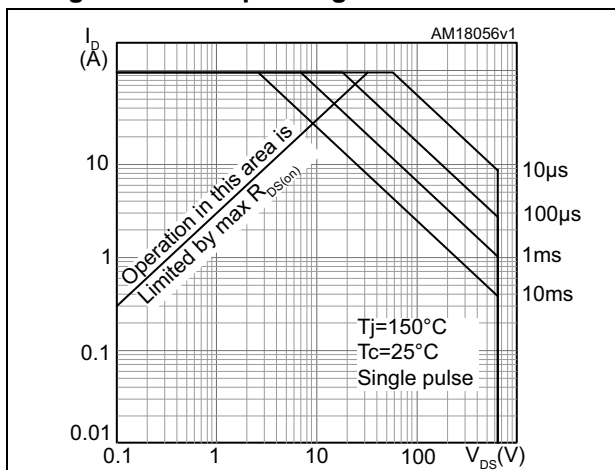

Figure 5. Thermal impedance for TO-220FP

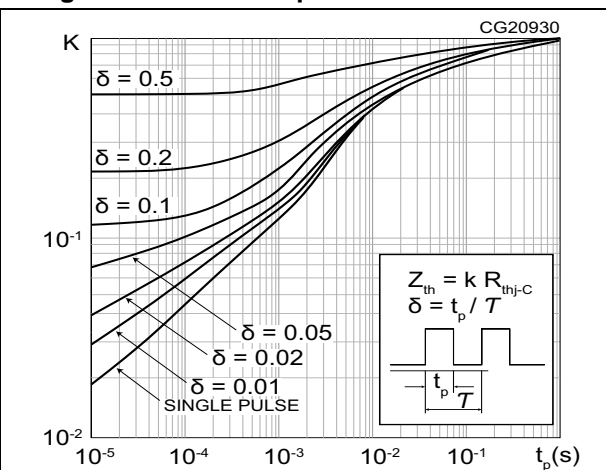

Figure 6. Output characteristics

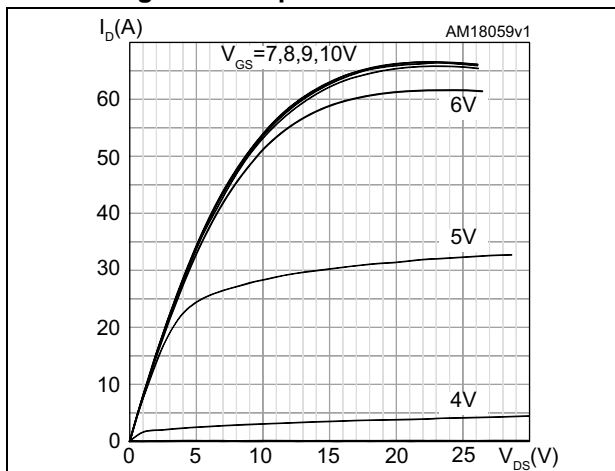

Figure 7. Transfer characteristics

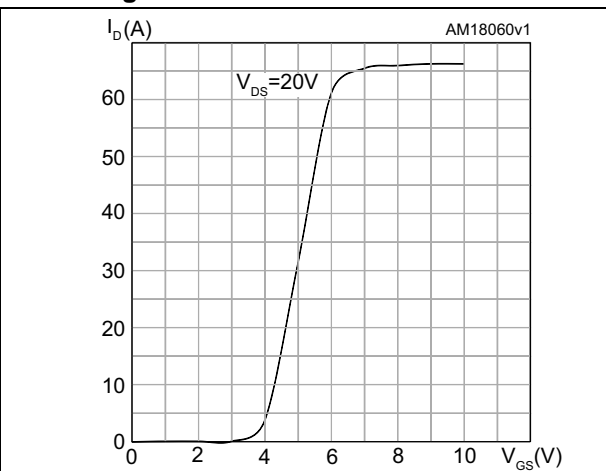

Figure 8. Gate charge vs gate-source voltage

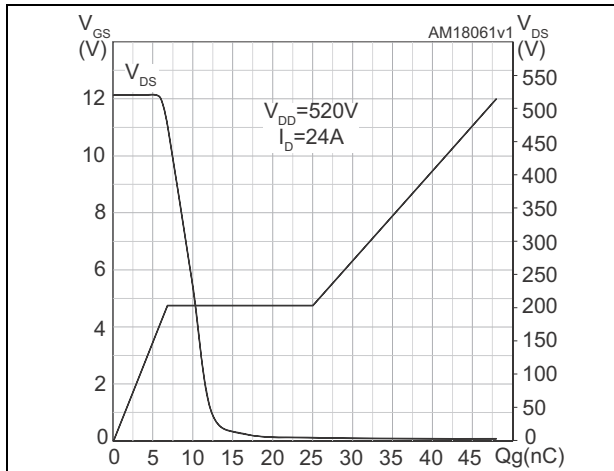

Figure 9. Static drain-source on-resistance

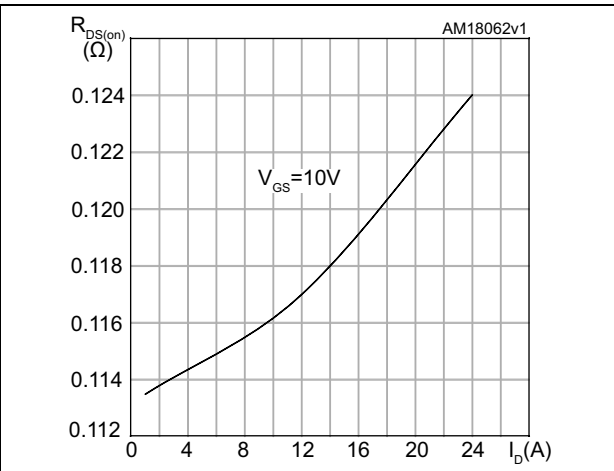

Figure 10. Capacitance variations

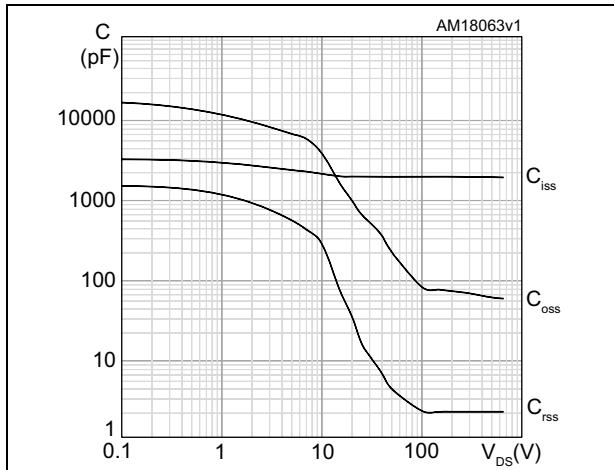

Figure 11. Output capacitance stored energy

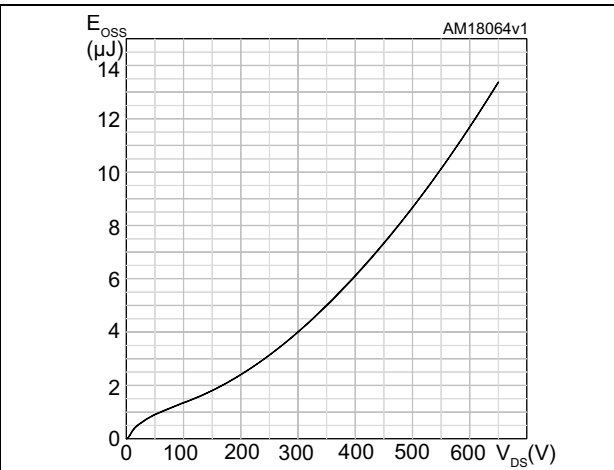

Figure 12. Normalized gate threshold voltage vs temperature

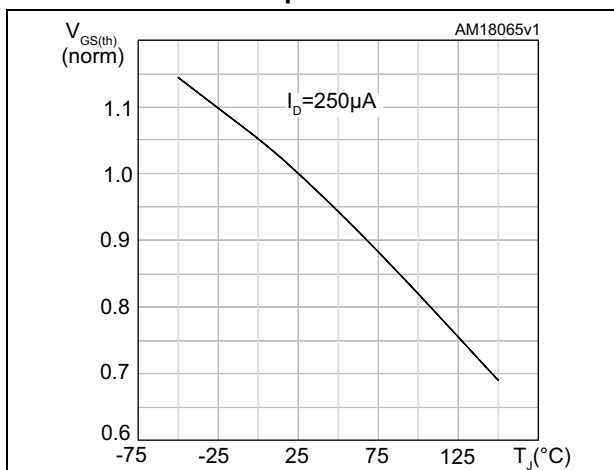

Figure 13. Normalized on-resistance vs temperature

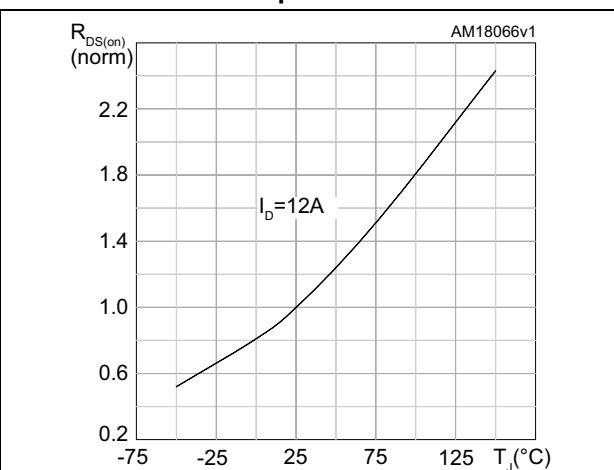

Figure 14. Source-drain diode forward characteristics

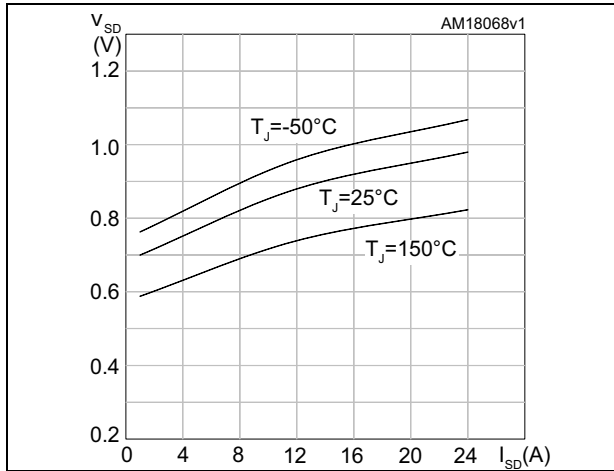
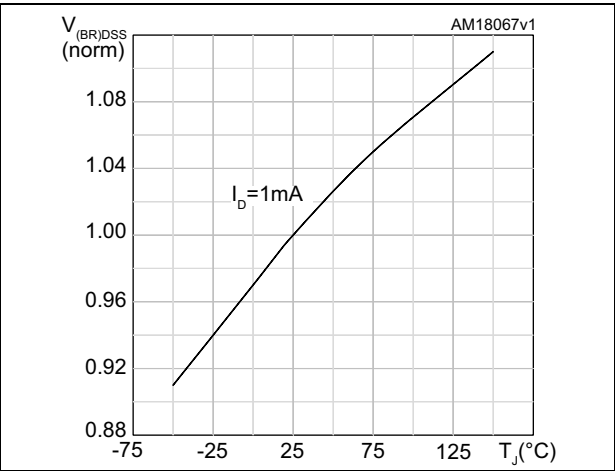

Figure 15. Normalized  $V_{(BR)DSS}$  vs temperature





### 3 Test circuits

Figure 16. Switching times test circuit for resistive load



Figure 17. Gate charge test circuit

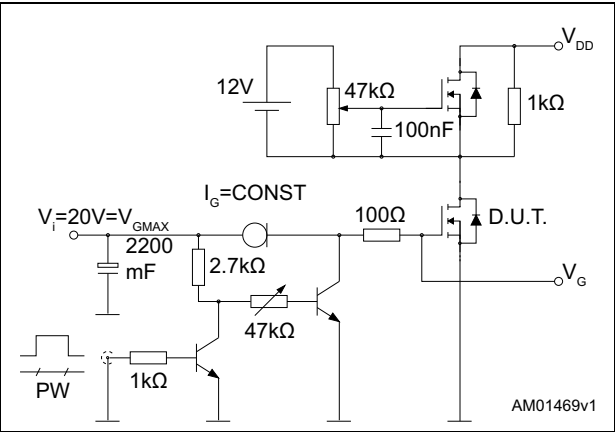

Figure 18. Test circuit for inductive load switching and diode recovery times



Figure 19. Unclamped inductive load test circuit

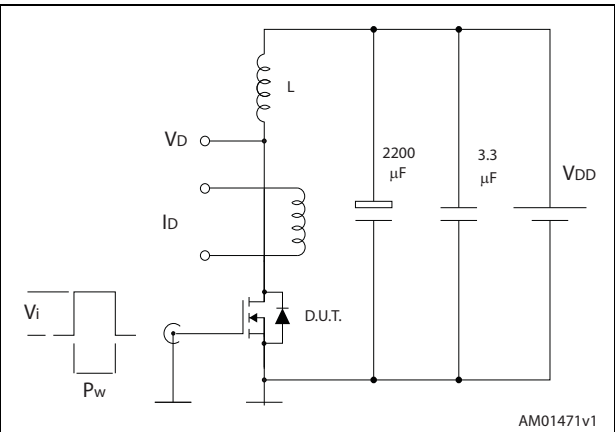

Figure 20. Unclamped inductive waveform

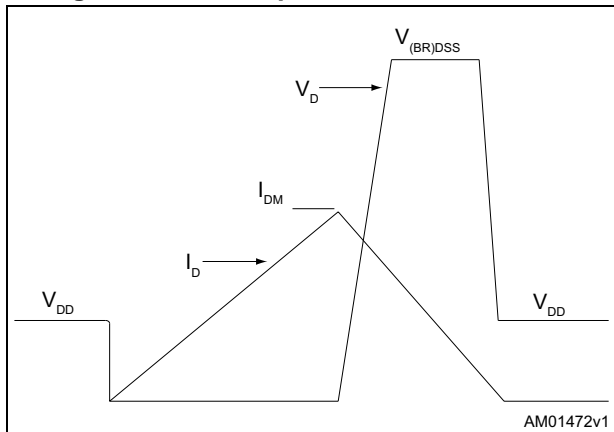
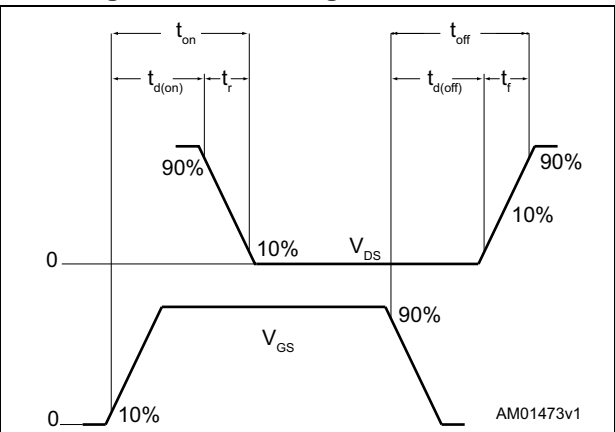

Figure 21. Switching time waveform



## 4 Package mechanical data

In order to meet environmental requirements, ST offers these devices in different grades of ECOPACK® packages, depending on their level of environmental compliance. ECOPACK® specifications, grade definitions and product status are available at: [www.st.com](http://www.st.com). ECOPACK® is an ST trademark.

### 4.1 D<sup>2</sup>PAK, STB33N65M2

Figure 22. D<sup>2</sup>PAK (TO-263) drawing

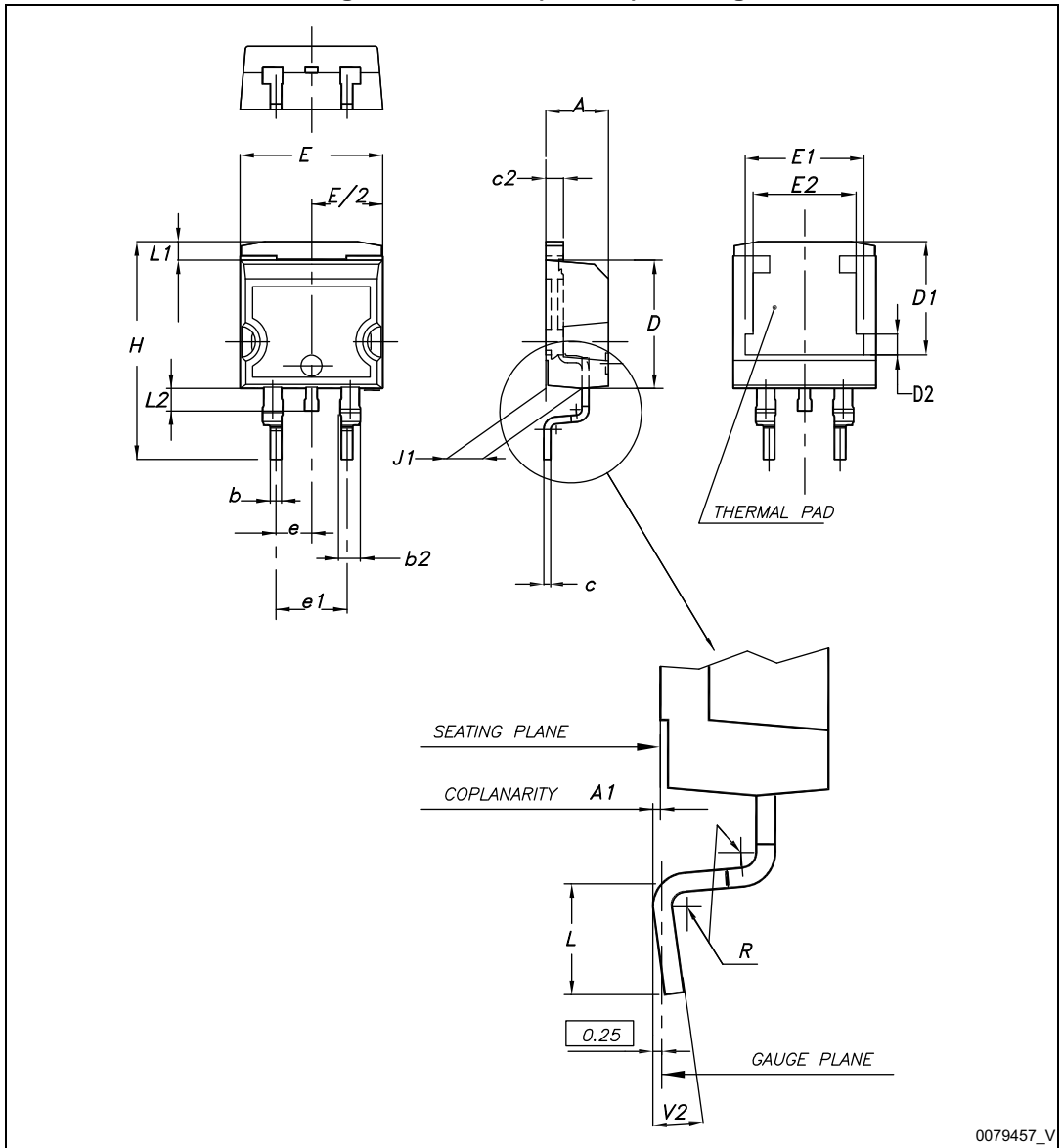
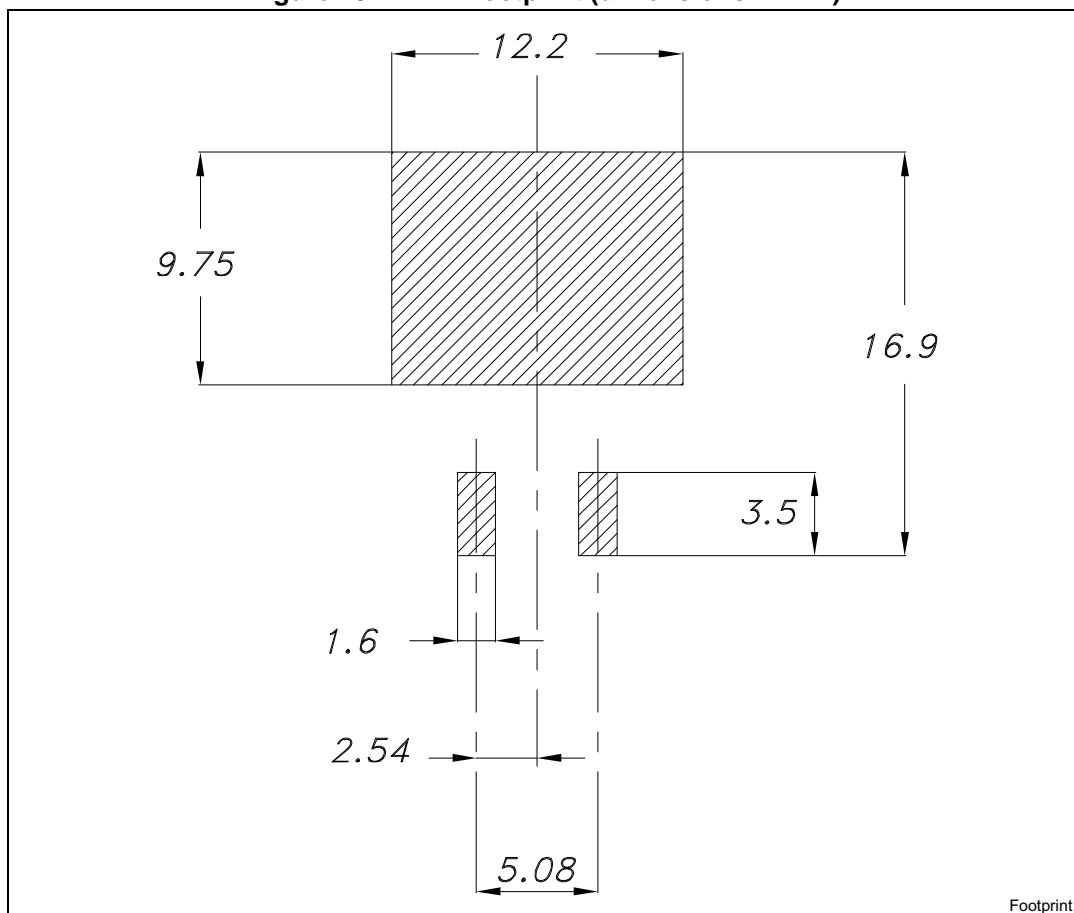

Table 9. D<sup>2</sup>PAK (TO-263) mechanical data

Dim.	mm		
	Min.	Typ.	Max.
A	4.40		4.60
A1	0.03		0.23
b	0.70		0.93
b2	1.14		1.70
c	0.45		0.60
c2	1.23		1.36
D	8.95		9.35
D1	7.50	7.75	8.00
D2	1.10	1.30	1.50
E	10		10.40
E1	8.50	8.70	8.90
E2	6.85	7.05	7.25
e		2.54	
e1	4.88		5.28
H	15		15.85
J1	2.49		2.69
L	2.29		2.79
L1	1.27		1.40
L2	1.30		1.75
R		0.4	
V2	0°		8°

Figure 23. D<sup>2</sup>PAK footprint (dimensions in mm)



### 4.2 TO-220FP, STF33N65M2

Figure 24. TO-220FP drawing

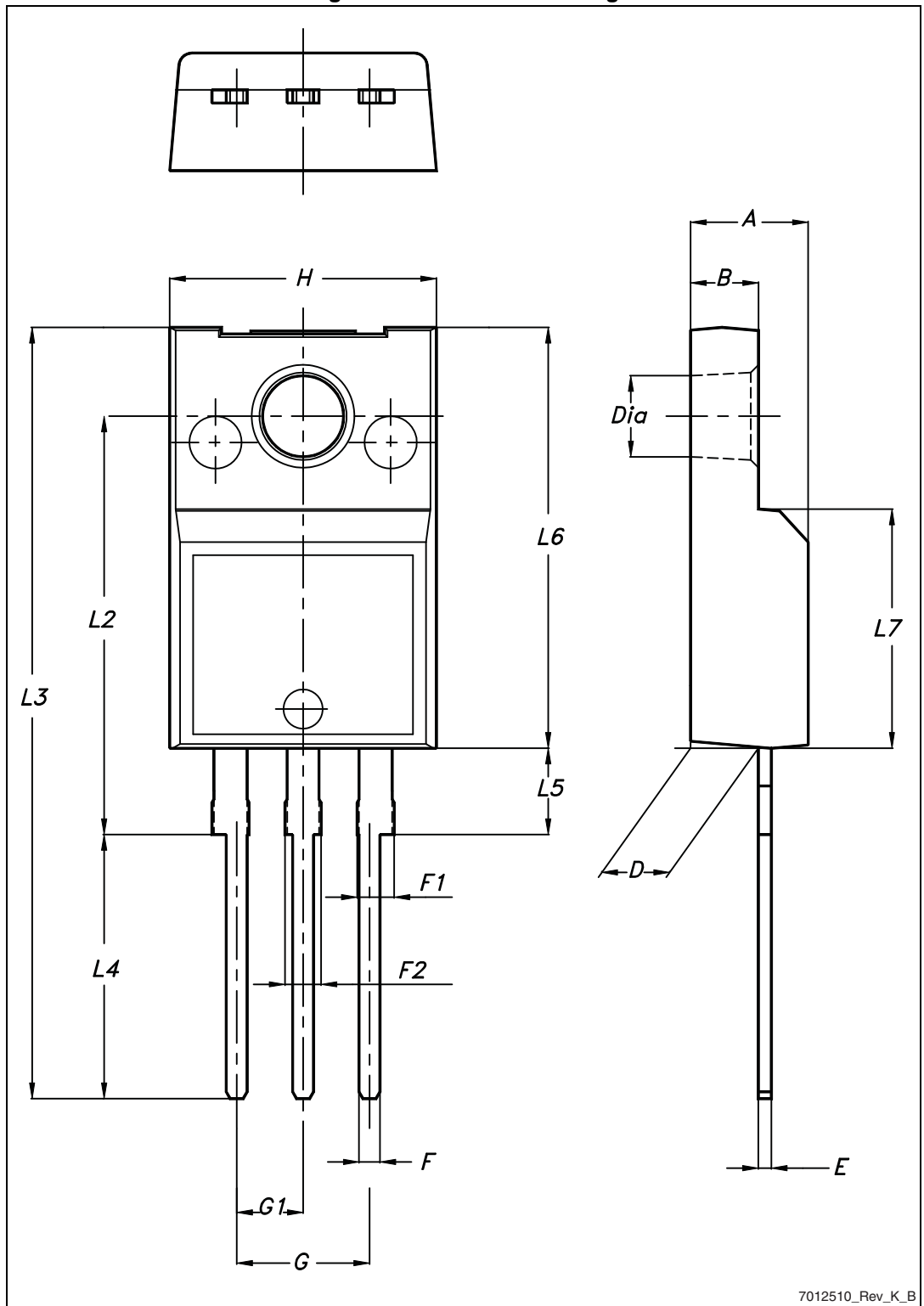

7012510\_Rev\_K\_B

Table 10. TO-220FP mechanical data

Dim.	mm		
	Min.	Typ.	Max.
A	4.4		4.6
B	2.5		2.7
D	2.5		2.75
E	0.45		0.7
F	0.75		1
F1	1.15		1.70
F2	1.15		1.70
G	4.95		5.2
G1	2.4		2.7
H	10		10.4
L2		16	
L3	28.6		30.6
L4	9.8		10.6
L5	2.9		3.6
L6	15.9		16.4
L7	9		9.3
Ø	3		3.2

4.3 TO-220, STP33N65M2

Figure 25. TO-220 type A drawing

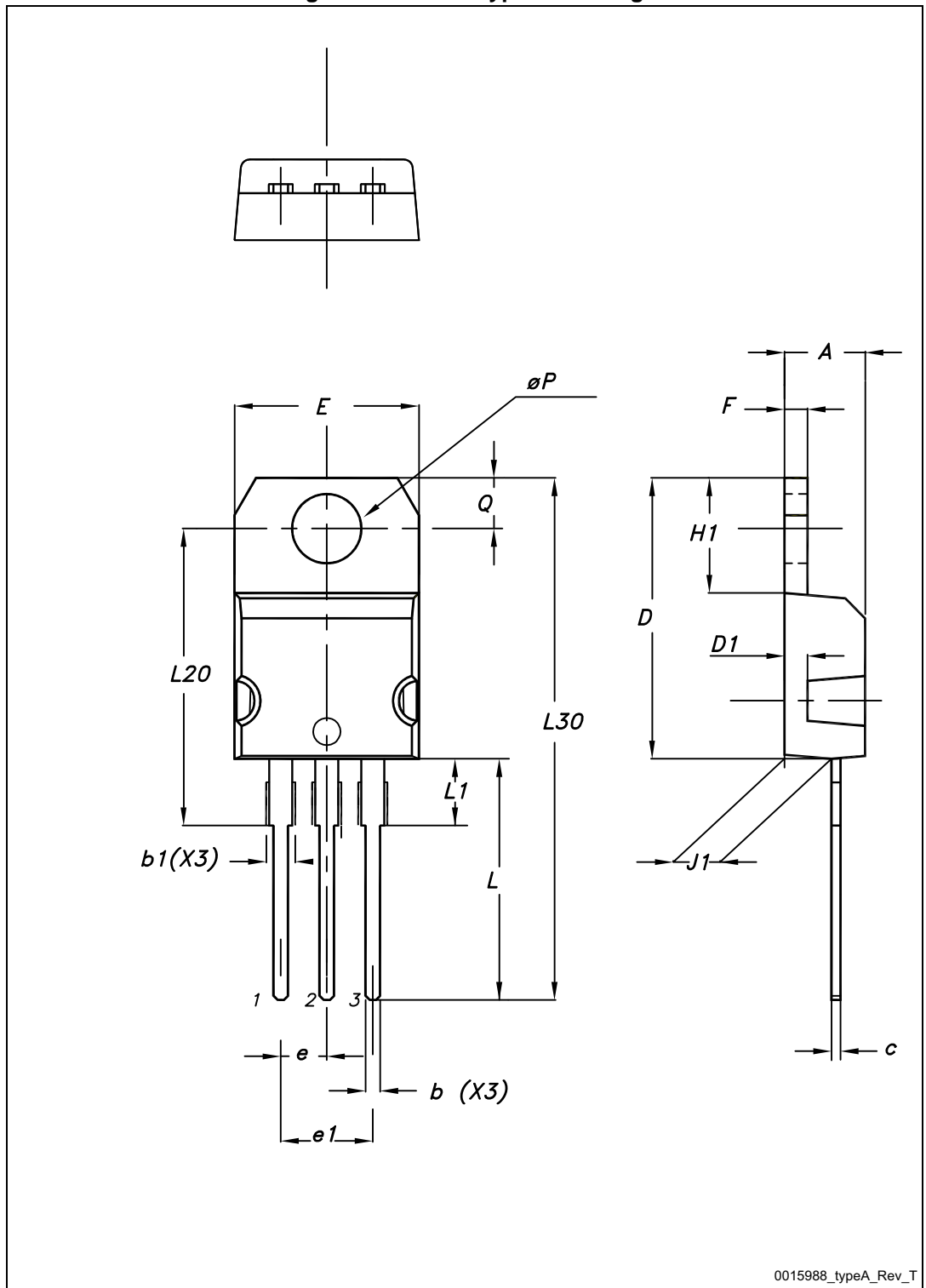

Table 11. TO-220 type A mechanical data

Dim.	mm		
	Min.	Typ.	Max.
A	4.40		4.60
b	0.61		0.88
b1	1.14		1.70
c	0.48		0.70
D	15.25		15.75
D1		1.27	
E	10		10.40
e	2.40		2.70
e1	4.95		5.15
F	1.23		1.32
H1	6.20		6.60
J1	2.40		2.72
L	13		14
L1	3.50		3.93
L20		16.40	
L30		28.90	
ØP	3.75		3.85
Q	2.65		2.95



### 4.4 I<sup>2</sup>PAK, STI33N65M2

Figure 26. I<sup>2</sup>PAK (TO-262) drawing

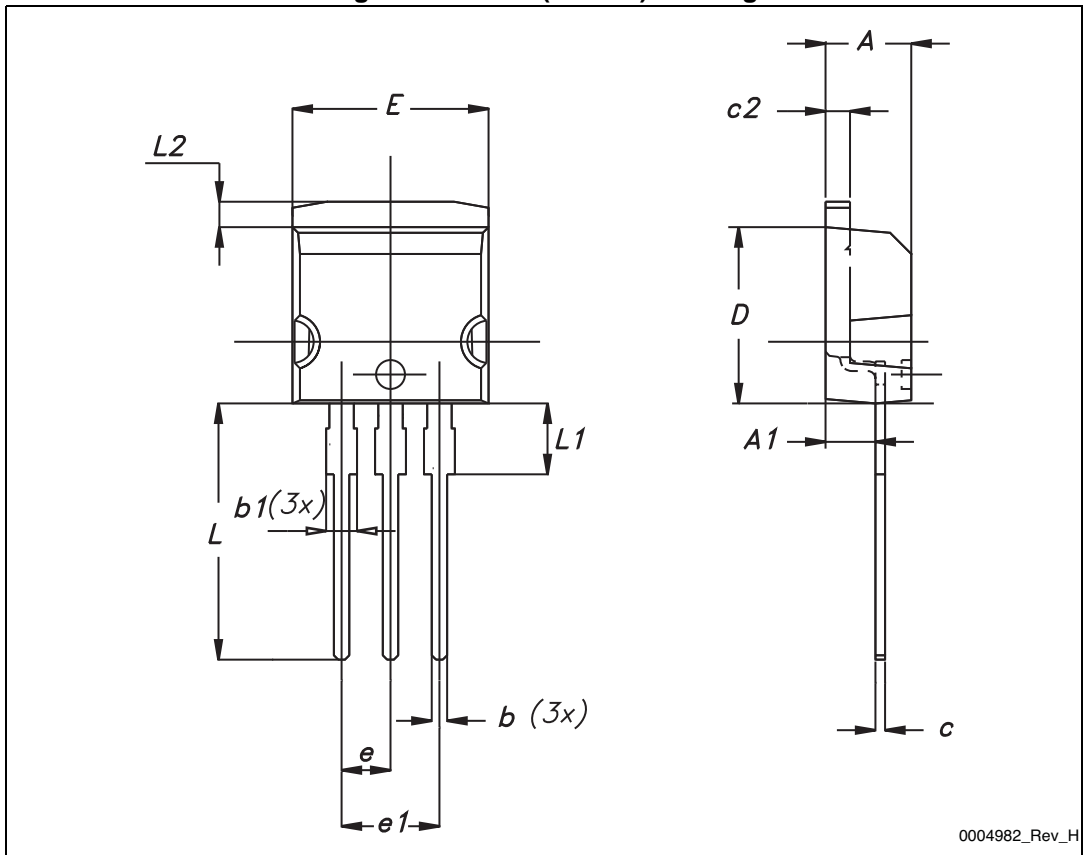

Table 12. I<sup>2</sup>PAK (TO-262) mechanical data

DIM.	mm.		
	min.	typ	max.
A	4.40		4.60
A1	2.40		2.72
b	0.61		0.88
b1	1.14		1.70
c	0.49		0.70
c2	1.23		1.32
D	8.95		9.35
e	2.40		2.70
e1	4.95		5.15
E	10		10.40
L	13		14
L1	3.50		3.93
L2	1.27		1.40

## 5 Packaging mechanical data

Figure 27. Tape for D<sup>2</sup>PAK (TO-263)

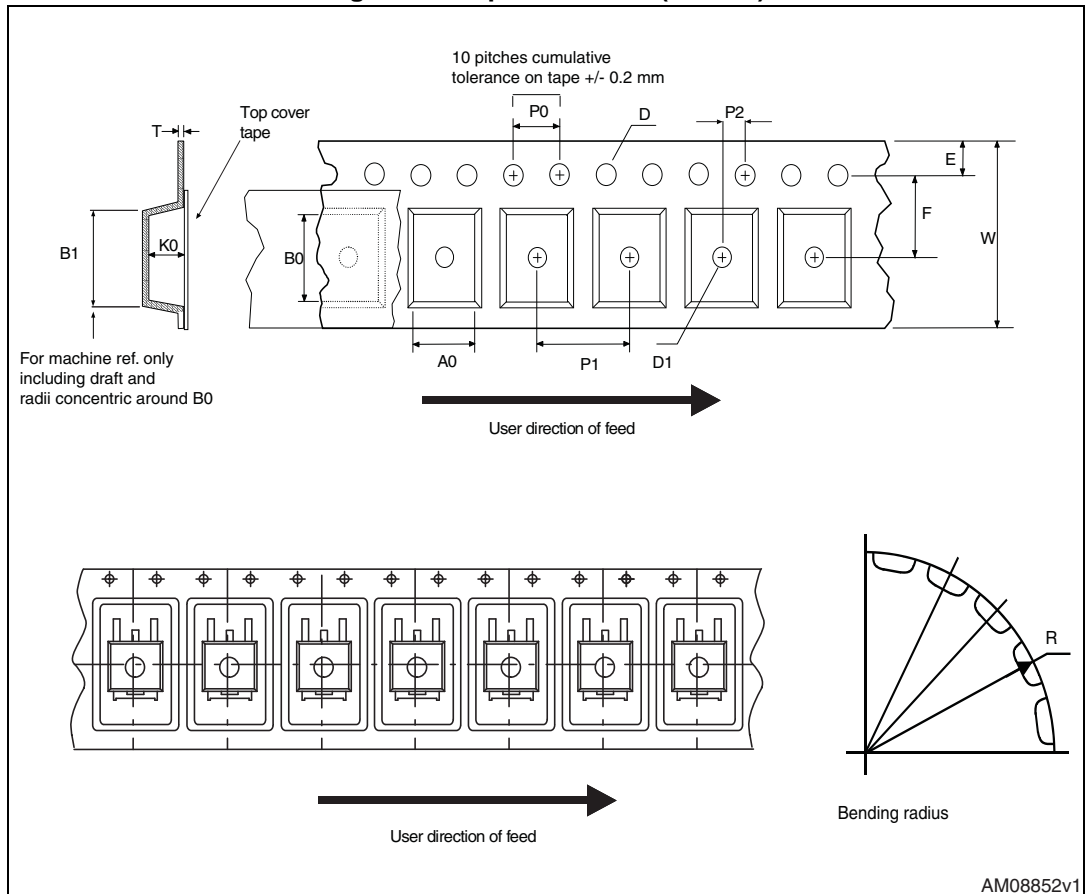

Figure 28. Reel for D<sup>2</sup>PAK (TO-263)

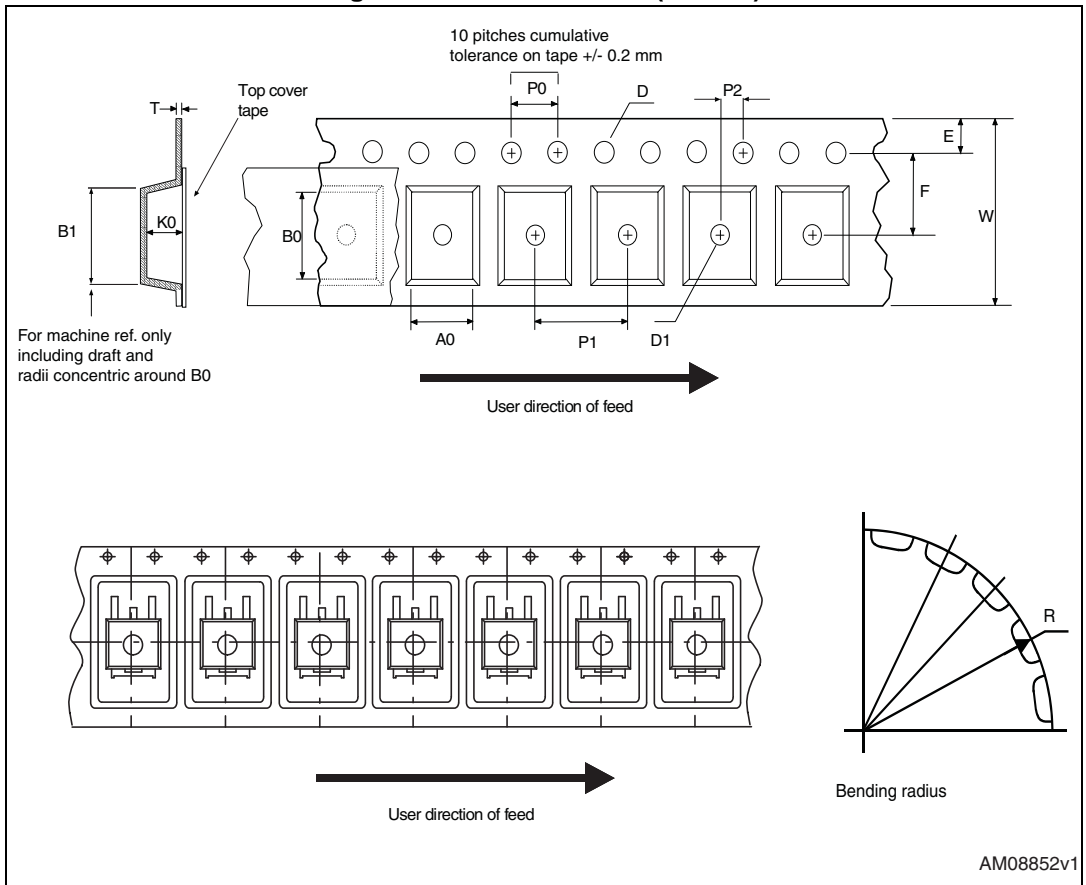

Table 13. D<sup>2</sup>PAK (TO-263) tape and reel mechanical data

Tape			Reel		
Dim.	mm		Dim.	mm	
	Min.	Max.		Min.	Max.
A0	10.5	10.7	A		330
B0	15.7	15.9	B	1.5	
D	1.5	1.6	C	12.8	13.2
D1	1.59	1.61	D	20.2	
E	1.65	1.85	G	24.4	26.4
F	11.4	11.6	N	100	
K0	4.8	5.0	T		30.4
P0	3.9	4.1			
P1	11.9	12.1	Base qty		1000
P2	1.9	2.1	Bulk qty		1000
R	50				
T	0.25	0.35			
W	23.7	24.3			

## 6 Revision history

Table 14. Document revision history

Date	Revision	Changes
10-Dec-2014	1	First release.

**IMPORTANT NOTICE – PLEASE READ CAREFULLY**

STMicroelectronics NV and its subsidiaries ("ST") reserve the right to make changes, corrections, enhancements, modifications, and improvements to ST products and/or to this document at any time without notice. Purchasers should obtain the latest relevant information on ST products before placing orders. ST products are sold pursuant to ST's terms and conditions of sale in place at the time of order acknowledgement.

Purchasers are solely responsible for the choice, selection, and use of ST products and ST assumes no liability for application assistance or the design of Purchasers' products.

No license, express or implied, to any intellectual property right is granted by ST herein.

Resale of ST products with provisions different from the information set forth herein shall void any warranty granted by ST for such product.

ST and the ST logo are trademarks of ST. All other product or service names are the property of their respective owners.

Information in this document supersedes and replaces information previously supplied in any prior versions of this document.

© 2014 STMicroelectronics – All rights reserved

