



STP22NM60 - STF22NM60 STB22NM60 - STB22NM60-1 - STW22NM60

N-CHANNEL 600V - 0.19 Ω - 22A TO-220/FP/D²PAK/I²PAK/TO-247
MDmesh™ Power MOSFET

ADVANCED DATA

TYPE	V _{DSS}	R _{DS(on)}	R _{ds(on)} *Q _g	I _D
STP22NM60	600 V	< 0.25 Ω	7.6 Ω *nC	22 A
STF22NM60	600 V	< 0.25 Ω	7.6 Ω *nC	22 A
STB22NM60	600 V	< 0.25 Ω	7.6 Ω *nC	22 A
STB22NM60-1	600 V	< 0.25 Ω	7.6 Ω *nC	22 A
STW22NM60	600 V	< 0.25 Ω	7.6 Ω *nC	22 A

- TYPICAL R_{DS(on)} = 0.19 Ω
- HIGH dv/dt AND AVALANCHE CAPABILITIES
- 100% AVALANCHE TESTED
- LOW INPUT CAPACITANCE AND GATE CHARGE
- LOW GATE INPUT RESISTANCE

DESCRIPTION

This improved version of MDmesh™ which is based on Multiple Drain process represents the new benchmark in high voltage MOSFETs. The resulting product exhibits even lower on-resistance, impressively high dv/dt and excellent avalanche characteristics. The adoption of the Company's proprietary strip technique yields overall performances that are significantly better than that of similar competition's products.

APPLICATIONS

The MDmesh™ family is very suitable for increasing power density of high voltage converters allowing system miniaturization and higher efficiencies.

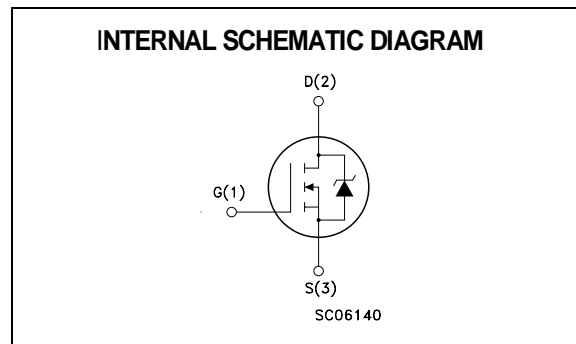
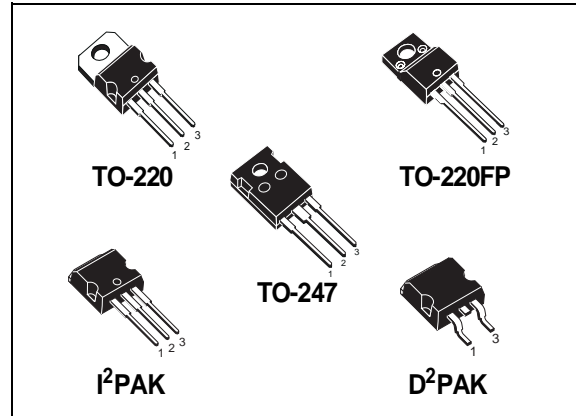

ORDERING INFORMATION

SALES TYPE	MARKING	PACKAGE	PACKAGING
STP22NM60	P22NM60	TO-220	TUBE
STF22NM60	F22NM60	TO-220FP	TUBE
STB22NM60	B22NM60T4	D ² PAK	TAPE & REEL
STB22NM60-1	B22NM60-1	I ² PAK	TUBE
STW22NM60	W22NM60	TO-247	TUBE

STP22NM60 / STF22NM60 / STB22NM60 / STB22NM60-1 - STW22NM60

ABSOLUTE MAXIMUM RATINGS

Symbol	Parameter	Value			Unit
		STP22NM60 STB22NM60/1	STF22NM60	STW22NM60	
V _{DS}	Drain-source Voltage (V _{GS} = 0)	600			V
V _{DGR}	Drain-gate Voltage (R _{GS} = 20 kΩ)	600			V
V _{GS}	Gate- source Voltage	±30			V
I _D	Drain Current (continuous) at T _C = 25°C	22	22 (*)	22	A
I _D	Drain Current (continuous) at T _C = 100°C	12.6	12.6 (*)	12.6	A
I _{DM} (•)	Drain Current (pulsed)	80	80(*)	80	A
P _{TOT}	Total Dissipation at T _C = 25°C	192	45	210	W
	Derating Factor	1.2	0.36	1.2	W/°C
dv/dt(1)	Peak Diode Recovery voltage slope	15			V/ns
V _{ISO}	Insulation Withstand Voltage (DC)	--	2500	--	V
T _{stg}	Storage Temperature	-65 to 150			°C
T _j	Max. Operating Junction Temperature	150			°C

(•) Pulse width limited by safe operating area;

(*) Limited only by maximum temperature allowed

(1) I_{SD} ≤ 22A, di/dt ≤ 400A/μs, V_{DD} ≤ V_{(BR)DSS}, T_j ≤ T_{JMAX}.

THERMAL DATA

		TO-220/D ² PAK/I ² PAK/TO-247	TO-220FP	
R _{thj-case}	Thermal Resistance Junction-case Max	0.65	2.8	°C/W
R _{thj-amb}	Thermal Resistance Junction-ambient Max	62.5		°C/W
T _l	Maximum Lead Temperature For Soldering Purpose	300		°C

AVALANCHE CHARACTERISTICS

Symbol	Parameter	Max Value	Unit
I _{AR}	Avalanche Current, Repetitive or Not-Repetitive (pulse width limited by T _j max)	11	A
E _{AS}	Single Pulse Avalanche Energy (starting T _j = 25 °C, I _D = I _{AR} , V _{DD} = 50 V)	650	mJ

ELECTRICAL CHARACTERISTICS (T_{CASE} = 25 °C UNLESS OTHERWISE SPECIFIED)

ON/OFF

Symbol	Parameter	Test Conditions	Min.	Typ.	Max.	Unit
V _{(BR)DSS}	Drain-source Breakdown Voltage	I _D = 250 μA, V _{GS} = 0	600			V
I _{DSS}	Zero Gate Voltage Drain Current (V _{GS} = 0)	V _{DS} = Max Rating V _{DS} = Max Rating, T _C = 125 °C			1 10	μA μA
I _{GSS}	Gate-body Leakage Current (V _{DS} = 0)	V _{GS} = ±30 V			±100	nA
V _{GS(th)}	Gate Threshold Voltage	V _{DS} = V _{GS} , I _D = 250 μA	3	4	5	V
R _{DS(on)}	Static Drain-source On Resistance	V _{GS} = 10 V, I _D = 11 A		0.19	0.25	Ω

ELECTRICAL CHARACTERISTICS (CONTINUE)
DYNAMIC

Symbol	Parameter	Test Conditions	Min.	Typ.	Max.	Unit
g_{fs} (1)	Forward Transconductance	$V_{DS} > I_{D(on)} \times R_{DS(on)max}$, $I_D = 11$ A		TBD		S
C_{iss} C_{oss} C_{rss}	Input Capacitance Output Capacitance Reverse Transfer Capacitance	$V_{DS} = 25$ V, $f = 1$ MHz, $V_{GS} = 0$		1590 803 52		pF pF pF
C_{oss} eq. (2)	Equivalent Output Capacitance	$V_{GS} = 0$ V, $V_{DS} = 0$ V to 400 V		130		pF
R_g	Gate Input Resistance	$f = 1$ MHz Gate DC Bias=0 Test Signal Level=20mV Open Drain		1.6		Ω

(1) Pulsed: Pulse duration = 300 μ s, duty cycle 1.5 %.

(*) C_{oss} eq. is defined as a constant equivalent capacitance giving the same charging time as C_{oss} when V_{DS} increases from 0 to 80% V_{DSS} .

SWITCHING ON

Symbol	Parameter	Test Conditions	Min.	Typ.	Max.	Unit
$t_{d(on)}$ t_r	Turn-on Delay Time Rise Time	$V_{DD} = 200$ V, $I_D = 11$ A $R_G = 4.7\Omega$, $V_{GS} = 10$ V (see test circuit, Figure 3)		25 20		ns ns
Q_g Q_{gs} Q_{gd}	Total Gate Charge Gate-Source Charge Gate-Drain Charge	$V_{DD} = 400$ V, $I_D = 22$ A, $V_{GS} = 10$ V		40 11 25	71	nC nC nC

SWITCHING OFF

Symbol	Parameter	Test Conditions	Min.	Typ.	Max.	Unit
$t_{r(voff)}$ t_f t_c	Off-voltage Rise Time Fall Time Cross-over Time	$V_{DD} = 480$ V, $I_D = 22$ A, $R_G = 4.7\Omega$, $V_{GS} = 10$ V (see test circuit, Figure 5)		13 15 26		ns ns ns

SOURCE DRAIN DIODE

Symbol	Parameter	Test Conditions	Min.	Typ.	Max.	Unit
I_{SD} I_{SDM} (2)	Source-drain Current Source-drain Current (pulsed)				20 80	A A
V_{SD} (1)	Forward On Voltage	$I_{SD} = 22$ A, $V_{GS} = 0$			1.5	V
t_{rr} Q_{rr} I_{rrm}	Reverse Recovery Time Reverse Recovery Charge Reverse Recovery Current	$I_{SD} = 22$ A, $di/dt = 100$ A/ μ s, $V_{DD} = 100$ V, $T_j = 25^\circ$ C (see test circuit, Figure 5)		416 5.6 27		ns μ C A
t_{rr} Q_{rr} I_{rrm}	Reverse Recovery Time Reverse Recovery Charge Reverse Recovery Current	$I_{SD} = 22$ A, $di/dt = 100$ A/ μ s, $V_{DD} = 100$ V, $T_j = 150^\circ$ C (see test circuit, Figure 5)		544 7.3 28		ns μ C A

Note: 1. Pulsed: Pulse duration = 300 μ s, duty cycle 1.5 %.
2. Pulse width limited by safe operating area.

Fig. 1: Unclamped Inductive Load Test Circuit

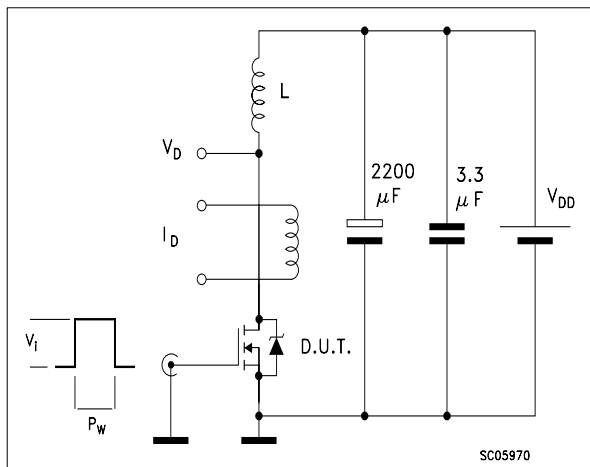

Fig. 2: Unclamped Inductive Waveform

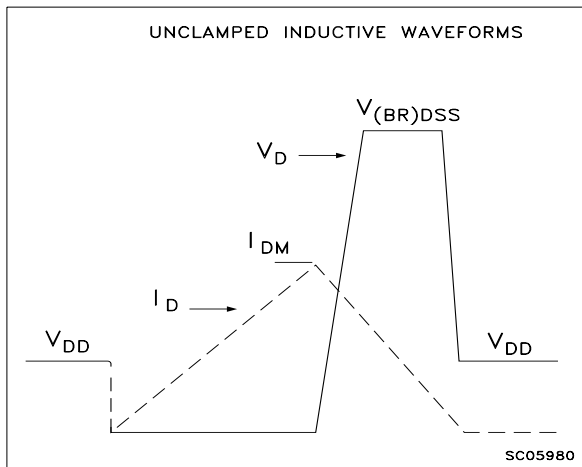

Fig. 3: Switching Times Test Circuit For Resistive Load

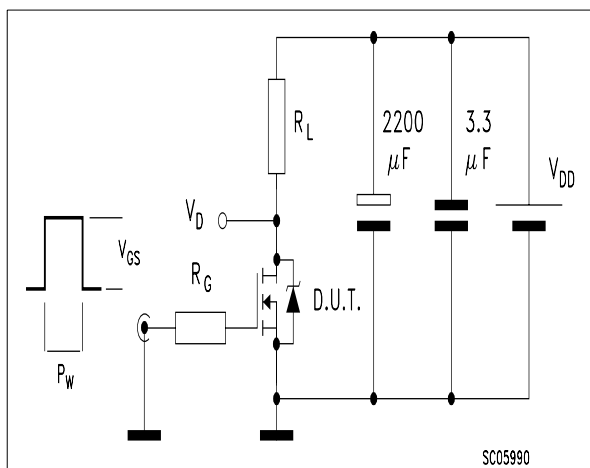

Fig. 4: Gate Charge test Circuit

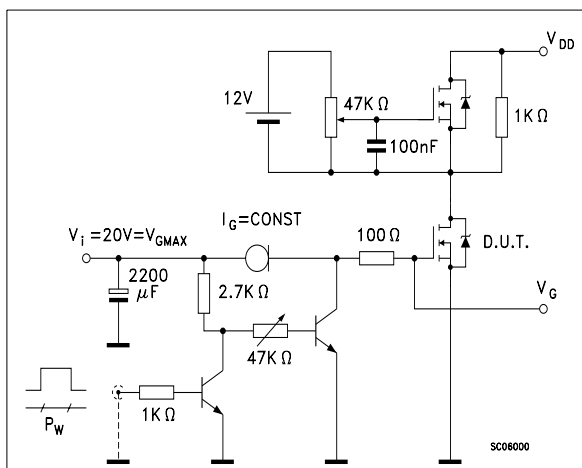
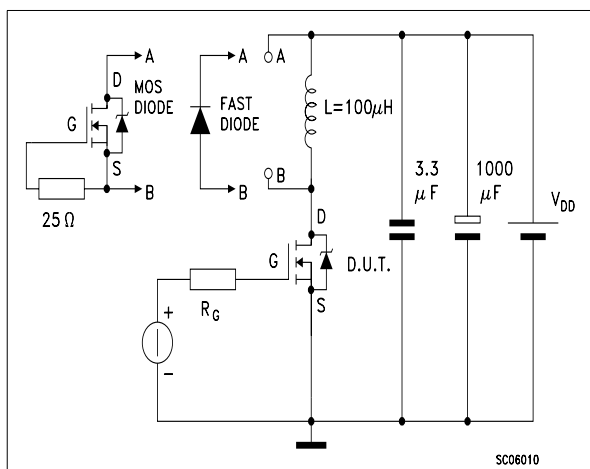
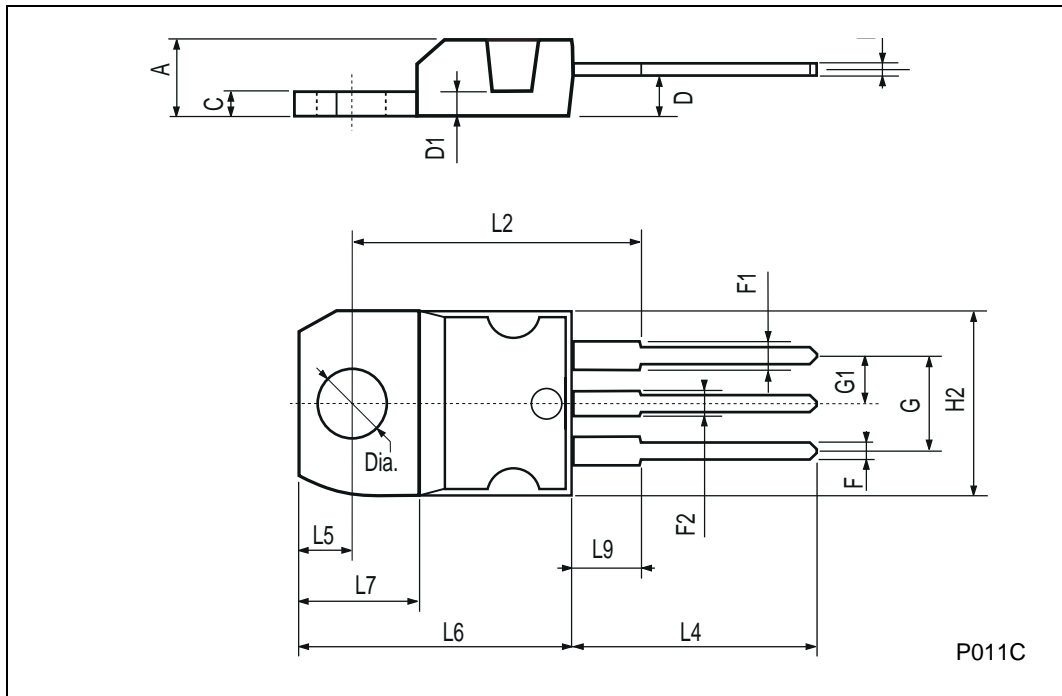

Fig. 5: Test Circuit For Inductive Load Switching And Diode Recovery Times



TO-220 MECHANICAL DATA

DIM.	mm			inch		
	MIN.	TYP.	MAX.	MIN.	TYP.	MAX.
A	4.40		4.60	0.173		0.181
C	1.23		1.32	0.048		0.051
D	2.40		2.72	0.094		0.107
D1		1.27			0.050	
E	0.49		0.70	0.019		0.027
F	0.61		0.88	0.024		0.034
F1	1.14		1.70	0.044		0.067
F2	1.14		1.70	0.044		0.067
G	4.95		5.15	0.194		0.203
G1	2.4		2.7	0.094		0.106
H2	10.0		10.40	0.393		0.409
L2		16.4			0.645	
L4	13.0		14.0	0.511		0.551
L5	2.65		2.95	0.104		0.116
L6	15.25		15.75	0.600		0.620
L7	6.2		6.6	0.244		0.260
L9	3.5		3.93	0.137		0.154
DIA.	3.75		3.85	0.147		0.151



TO-220FP MECHANICAL DATA

DIM.	mm.			inch		
	MIN.	TYP	MAX.	MIN.	TYP.	MAX.
A	4.4		4.6	0.173		0.181
B	2.5		2.7	0.098		0.106
D	2.5		2.75	0.098		0.108
E	0.45		0.7	0.017		0.027
F	0.75		1	0.030		0.039
F1	1.15		1.7	0.045		0.067
F2	1.15		1.7	0.045		0.067
G	4.95		5.2	0.195		0.204
G1	2.4		2.7	0.094		0.106
H	10		10.4	0.393		0.409
L2		16			0.630	
L3	28.6		30.6	1.126		1.204
L4	9.8		10.6	.0385		0.417
L5	2.9		3.6	0.114		0.141
L6	15.9		16.4	0.626		0.645
L7	9		9.3	0.354		0.366
∅	3		3.2	0.118		0.126

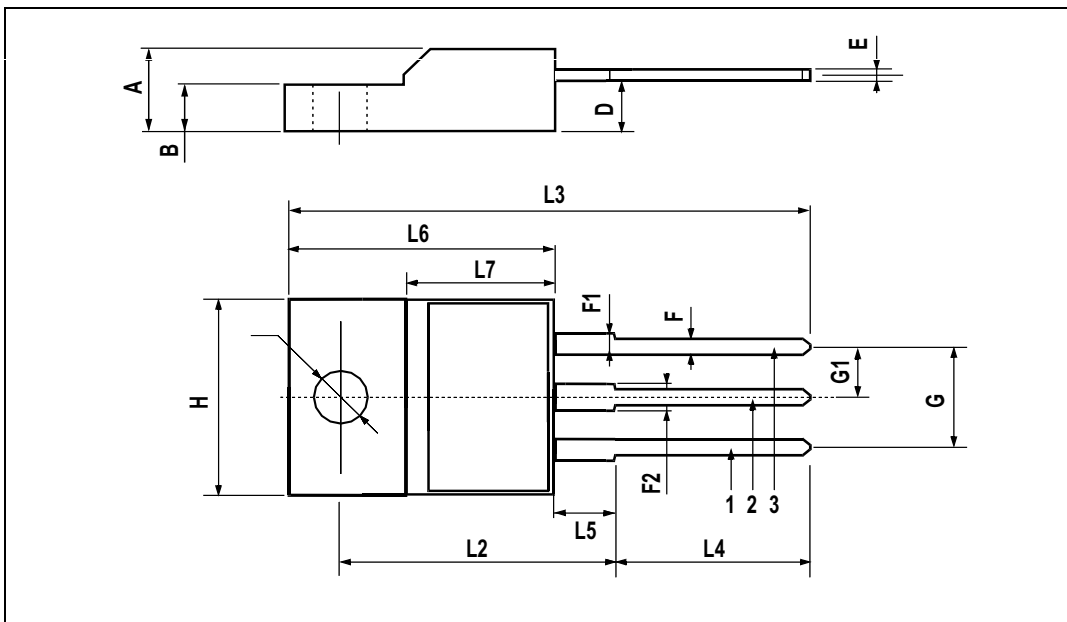

D²PAK MECHANICAL DATA

DIM.	mm.			inch		
	MIN.	TYP	MAX.	MIN.	TYP.	MAX.
A	4.4		4.6	0.173		0.181
A1	2.49		2.69	0.098		0.106
A2	0.03		0.23	0.001		0.009
B	0.7		0.93	0.027		0.036
B2	1.14		1.7	0.044		0.067
C	0.45		0.6	0.017		0.023
C2	1.23		1.36	0.048		0.053
D	8.95		9.35	0.352		0.368
D1		8			0.315	
E	10		10.4	0.393		
E1		8.5			0.334	
G	4.88		5.28	0.192		0.208
L	15		15.85	0.590		0.625
L2	1.27		1.4	0.050		0.055
L3	1.4		1.75	0.055		0.068
M	2.4		3.2	0.094		0.126
R		0.4			0.015	
V2	0°		8°			

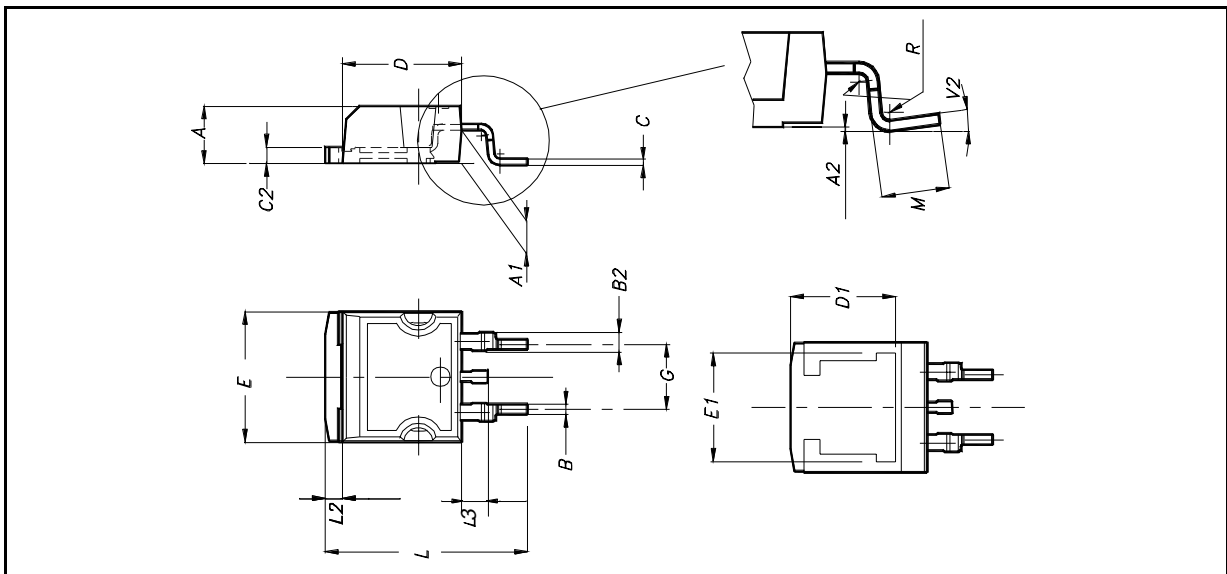

TO-262 (I²PAK) MECHANICAL DATA

DIM.	mm			inch		
	MIN.	TYP.	MAX.	MIN.	TYP.	MAX.
A	4.4		4.6	0.173		0.181
A1	2.49		2.69	0.098		0.106
B	0.7		0.93	0.027		0.036
B2	1.14		1.7	0.044		0.067
C	0.45		0.6	0.017		0.023
C2	1.23		1.36	0.048		0.053
D	8.95		9.35	0.352		0.368
e	2.4		2.7	0.094		0.106
E	10		10.4	0.393		0.409
L	13.1		13.6	0.515		0.531
L1	3.48		3.78	0.137		0.149
L2	1.27		1.4	0.050		0.055

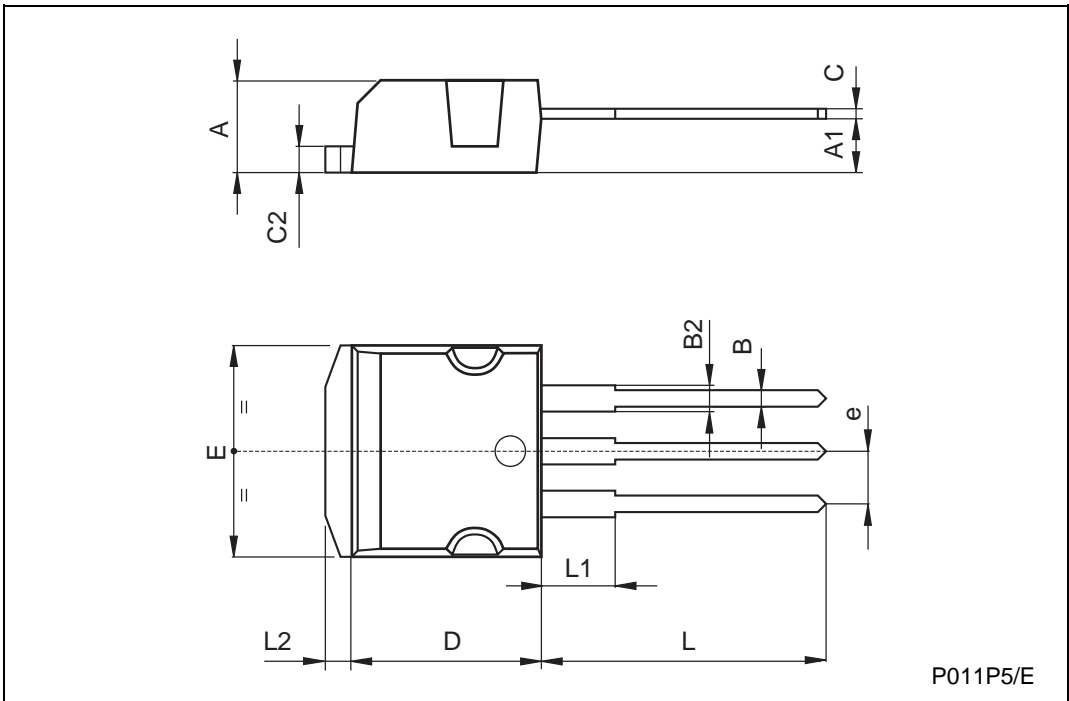

D²PAK FOOTPRINT

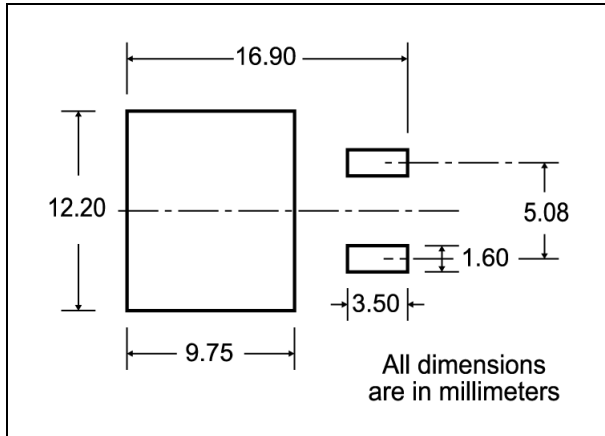

TUBE SHIPMENT (no suffix)*

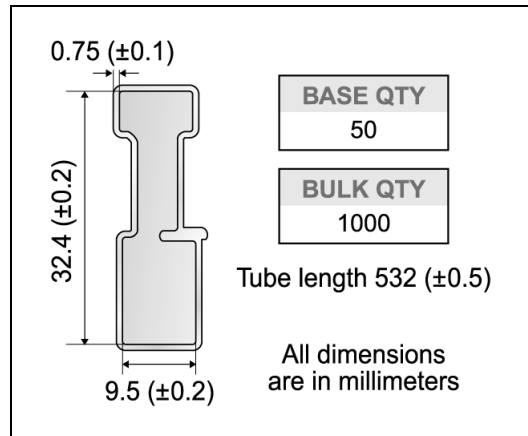

TAPE AND REEL SHIPMENT (suffix "T4")*

Diagram showing the tape mechanical data. It includes a circular reel view with dimensions A, B, C, D, and a full radius. A slot in the core is shown with a 2.5mm min. width and a 40 mm min. access hole at the slot location. A side view shows dimensions T, C, N, and G (measured at hub).

TAPE MECHANICAL DATA

DIM.	mm		inch	
	MIN.	MAX.	MIN.	MAX.
A0	10.5	10.7	0.413	0.421
B0	15.7	15.9	0.618	0.626
D	1.5	1.6	0.059	0.063
D1	1.59	1.61	0.062	0.063
E	1.65	1.85	0.065	0.073
F	11.4	11.6	0.449	0.456
K0	4.8	5.0	0.189	0.197
P0	3.9	4.1	0.153	0.161
P1	11.9	12.1	0.468	0.476
P2	1.9	2.1	0.075	0.082
R	50		1.574	
T	0.25	0.35	0.0098	0.0137
W	23.7	24.3	0.933	0.956

REEL MECHANICAL DATA

DIM.	mm		inch	
	MIN.	MAX.	MIN.	MAX.
A		330		12.992
B	1.5		0.059	
C	12.8	13.2	0.504	0.520
D	20.2		0.795	
G	24.4	26.4	0.960	1.039
N	100		3.937	
T		30.4		1.197

BASE QTY	1000
BULK QTY	1000

Diagram showing the reel and tape mechanical data. It includes a side view of the reel with dimensions K₀, T, D, P₂, P₀, E, F, W, B₀, D₁, A₀, P₁, and a center line of cavity. A top view shows the tape with dimensions A₀, P₁, and P₂. A bending radius diagram shows a minimum bending radius R min. The user direction of feed and feed direction are also indicated.

10 pitches cumulative tolerance on tape + / - 0.2 mm

Center line of cavity

User Direction of Feed

FEED DIRECTION

Bending radius

TRL

* on sales type



TO-247 MECHANICAL DATA

DIM.	mm.			inch		
	MIN.	TYP.	MAX.	MIN.	TYP.	MAX.
A	4.85		5.15	0.19		0.20
A1	2.20		2.60	0.086		0.102
b	1.0		1.40	0.039		0.055
b1	2.0		2.40	0.079		0.094
b2	3.0		3.40	0.118		0.134
c	0.40		0.80	0.015		0.03
D	19.85		20.15	0.781		0.793
E	15.45		15.75	0.608		0.620
e		5.45			0.214	
L	14.20		14.80	0.560		0.582
L1	3.70		4.30	0.14		0.17
L2		18.50			0.728	
øP	3.55		3.65	0.140		0.143
øR	4.50		5.50	0.177		0.216
S		5.50			0.216	

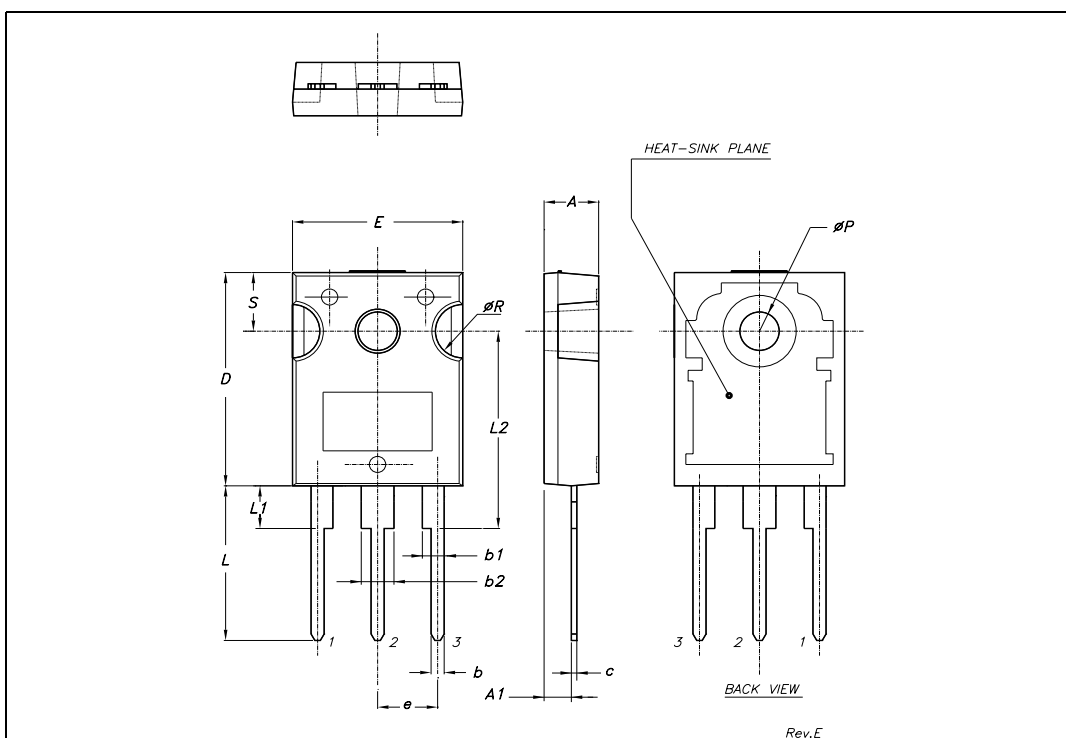

Information furnished is believed to be accurate and reliable. However, STMicroelectronics assumes no responsibility for the consequences of use of such information nor for any infringement of patents or other rights of third parties which may result from its use. No license is granted by implication or otherwise under any patent or patent rights of STMicroelectronics. Specifications mentioned in this publication are subject to change without notice. This publication supersedes and replaces all information previously supplied. STMicroelectronics products are not authorized for use as critical components in life support devices or systems without express written approval of STMicroelectronics.

© The ST logo is a registered trademark of STMicroelectronics

© 2003 STMicroelectronics - Printed in Italy - All Rights Reserved
STMicroelectronics GROUP OF COMPANIES

Australia - Brazil - Canada - China - Finland - France - Germany - Hong Kong - India - Israel - Italy - Japan - Malaysia - Malta - Morocco
Singapore - Spain - Sweden - Switzerland - United Kingdom - United States.

© <http://www.st.com>