

Electronic fuse for 3.3 V and 5 V lines

Datasheet - production data



Features

- Power MOSFET on-resistance (typ.): 40 mΩ
- Enable function
- Output clamp voltage (typ.): 5.7 V in 5 V mode, and 3.8 V in 3.3 V mode
- Undervoltage lockout
- Short-circuit limit
- Overload foldback current limit
- Controlled soft-start
- Thermal auto-retry
- Internal sensing FET
- Operative temp. range: - 40 °C to 85 °C
- Available in DFN 3x3 10L package

Description

The STEF4S is an integrated electronic fuse optimized for monitoring the output current and the input voltage. It can be connected in series to 3.3 V or 5 V rails, protecting the electronic circuitry on its output from overcurrent and overvoltage. The operating mode (5 V or 3.3 V) can be selected by a dedicated pin. The STEF4S has a controlled turn-on time, adjustable by an external capacitor. When an overload condition occurs the device limits the output current to a

predefined safe value. If the anomalous overload condition persists it goes into an open state, disconnecting the load from the power supply. If a continuous short-circuit is present on the board, the E-fuse limits the output current to a safe value.

In case of overvoltage on the input, the device clamps the output voltage to a predefined value and protects the load.

If the anomalous fault condition persists, the internal thermal protection circuit shuts down the device and then automatically attempts to re-supply the load until the fault condition is removed.

Unlike mechanical fuses, which must be physically replaced after a single event, the E-fuse does not degrade in its performance after short-circuit/thermal protection interventions.

Applications

- Hard disk drives
- Solid state drives (SSD)
- Hard disk and SSD arrays
- Set-top boxes
- DVD and blu-ray disc drivers

Table 1. Device summary

| Order code | Package | Packing |
|------------|-------------|---------------|
| STEF4SPUR | DFN 3x3 10L | Tape and reel |

Contents

| | | |
|----------|--|-----------|
| 1 | Block diagram | 3 |
| 2 | Pin configuration | 4 |
| 3 | Maximum ratings | 5 |
| 4 | Electrical characteristics | 6 |
| 5 | Typical characteristics | 8 |
| 5.1 | Operating modes | 9 |
| 5.1.1 | Turn-on | 9 |
| 5.1.2 | Normal operating condition | 9 |
| 5.1.3 | Output voltage clamp | 9 |
| 5.1.4 | Current limiting | 9 |
| 5.1.5 | Thermal shutdown and auto-retry function | 9 |
| 5.2 | Startup time and CSS calculation | 9 |
| 5.3 | UVLO and voltage clamp selection | 10 |
| 5.4 | Enable pin | 10 |
| 6 | Typical performance characteristics | 11 |
| 7 | Package mechanical data | 14 |
| 8 | Packaging mechanical data | 17 |
| 9 | Revision history | 20 |

1 Block diagram

Figure 1. Device block diagram

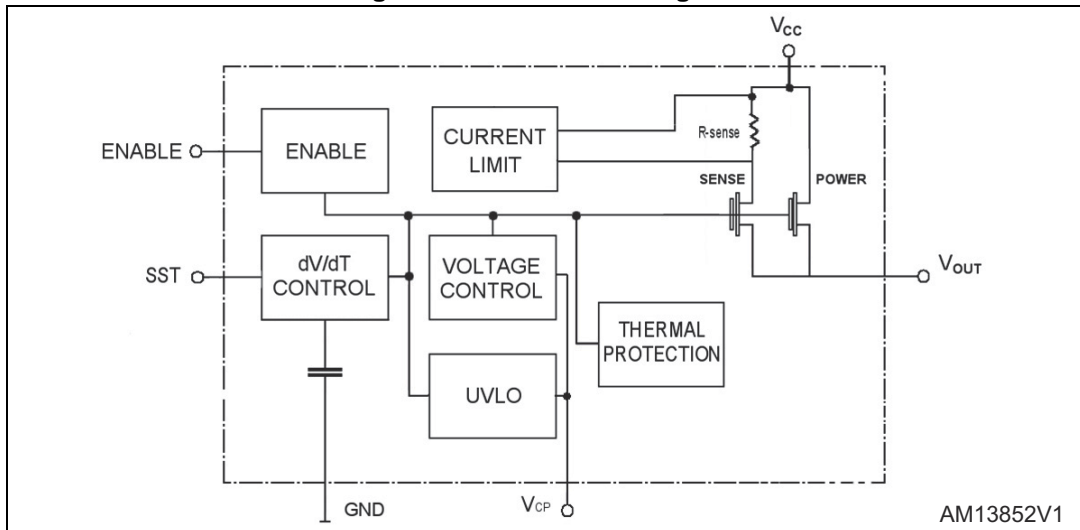

2 Pin configuration

Figure 2. Pin configuration (top view)

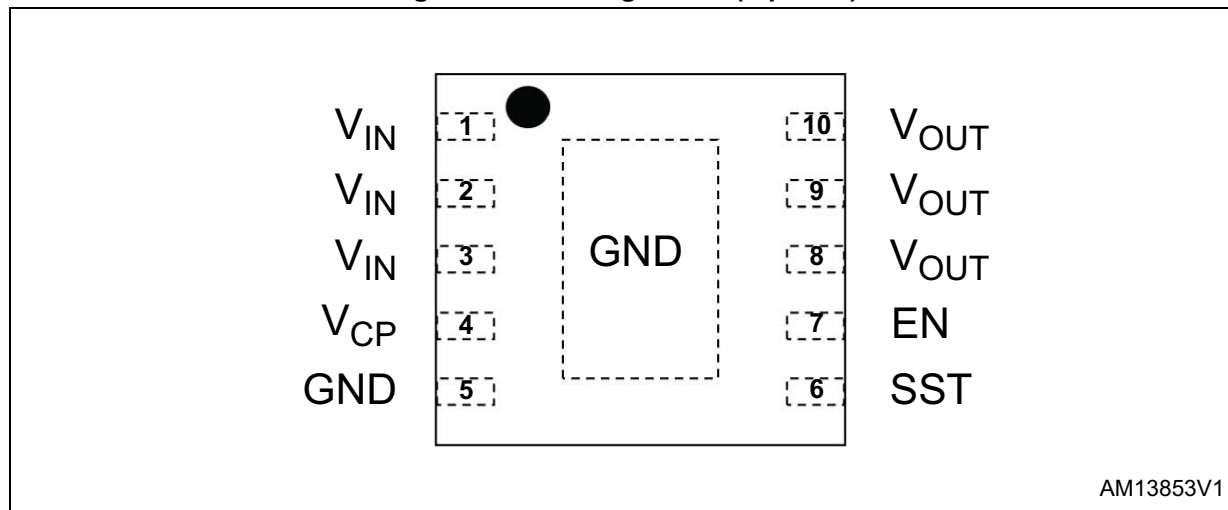

Table 2. Pin description

| Pin n° | Symbol | Note |
|---------|-----------|---|
| 1, 2, 3 | V_{IN} | Input supply voltage pin |
| 4 | V_{CP} | Voltage clamping and UVLO selection pin (high state 5 V, low state 3.3 V) |
| 5 | GND | Ground pin (can be left floating if TAB is connected to GND) |
| 6 | SST | Soft-start time selection pin. A capacitor can be connected between this pin and GND to increase the startup time |
| 7 | EN | Enable pin (active high) |
| 8,9,10 | V_{OUT} | Output voltage pin |
| EXP | GND | Exposed pad is internally connected to GND |

3 Maximum ratings

Table 3. Absolute maximum ratings

| Symbol | Parameter | Value | Unit |
|------------|--|------------------|------|
| V_{IN} | Positive power supply voltage | -0.3 to 15 | V |
| V_{OUT} | Output voltage | -0.3 to 7 | V |
| V_{CP} | UVLO and voltage clamp selection pin | -0.3 to V_{IN} | V |
| EN | Enable pin | -0.3 to V_{IN} | V |
| SST | Soft-start time selection pin | -0.3 to 4.6 | V |
| T_J | Max. junction temperature ⁽¹⁾ | -40 to 125 | °C |
| T_{STG} | Storage temperature range | -65 to 150 | °C |
| T_{LEAD} | Lead temperature (soldering) 10 s | 260 | °C |

1. The thermal limit is set above the maximum thermal rating. It is not recommended the device to operate at temperatures greater than the maximum ratings for extended periods of time.

Note: Absolute maximum ratings are those values beyond which damage to the device may occur. Functional operation under these conditions is not implied.

Table 4. Thermal data

| Symbol | Parameter | Value | Unit |
|------------|-------------------------------------|-------|------|
| R_{thJA} | Thermal resistance junction-ambient | 40 | °C/W |
| R_{thJC} | Thermal resistance junction-case | 2.5 | °C/W |

4 Electrical characteristics

Unless otherwise specified, typical values are referred to $V_{IN} = 5\text{ V}$ for $V_{CP} = V_{IN}$ and $V_{IN} = 3.3\text{ V}$ for $V_{CP} = \text{GND}$, $T = 25\text{ }^\circ\text{C}$, min. and max. values are referred to $T = -40\text{ }^\circ\text{C}$ to $85\text{ }^\circ\text{C}$.

Table 5. STEF4S electrical characteristics

| Symbol | Parameter | Test conditions | Min. | Typ. | Max. | Unit |
|---|--|--|------|------|------|------------|
| V_{IN} | Operating input voltage | | | | 10 | V |
| Under/overvoltage protection, 3.3 V mode | | | | | | |
| V_{Clamp} | Output clamping voltage | $V_{IN} = 10\text{ V}$, $V_{CP} = \text{GND}$ | 3.6 | 3.8 | 4.0 | V |
| V_{UVLO} | Under voltage lockout | $V_{CP} = \text{GND}$, Turn-on, voltage going up | 2.2 | 2.3 | 2.4 | V |
| V_{Hyst} | UVLO hysteresis | $V_{CP} = \text{GND}$ | 50 | 90 | 130 | mV |
| Under/overvoltage protection, 5 V mode | | | | | | |
| V_{Clamp} | Output clamping voltage | $V_{IN} = 10\text{ V}$, $V_{CP} = V_{IN}$ | 5.4 | 5.7 | 6.0 | V |
| V_{UVLO} | Under voltage lockout | $V_{CP} = V_{IN}$, Turn-on, voltage going up | 3.4 | 3.6 | 3.8 | V |
| V_{Hyst} | UVLO hysteresis | $V_{CP} = V_{IN}$ | 60 | 105 | 150 | mV |
| Power MOSFET | | | | | | |
| $R_{DS(on)}$ | ON-resistance $R_{DS(on)} = (V_{IN} - V_{OUT}) / I_{OUT}$ | | | 40 | | m Ω |
| | | $T_j = 85\text{ }^\circ\text{C}^{(1)}$ | | | 70 | |
| Current limit | | | | | | |
| I_{OL} | Protection trip current | | | 5 | | A |
| I_{Lim} | Overload current limit | | 5 | 7 | 9 | A |
| I_{Short} | Short-circuit current limit | $V_{OUT} = 0\text{ V}$ | | 3 | | A |
| Soft-start circuit | | | | | | |
| T_{SS} | Output voltage ramp time | From $V_{IN} = V_{UVLO}$ to $V_{OUT} = 90\%$, no C_{SS} | | 0.6 | | ms |
| | | From $V_{IN} = V_{UVLO}$ to $V_{OUT} = 90\%$, $C_{SS} = 100\text{ nF}$ | 16 | 23 | 30 | |
| Enable pin thresholds | | | | | | |
| V_{EN-L} | Enable pin switch-off voltage | Output disabled | | | 0.4 | V |
| V_{EN-H} | Enable pin switch-on voltage | Output enabled | 2 | | | V |
| V_{CP} pin thresholds | | | | | | |
| V_{CP-L} | 3.3 V mode selection threshold | 3.3 V mode enabled | | | 0.4 | V |
| V_{CP-H} | 5 V mode selection threshold | 5 V mode enabled | 2 | | | V |

Table 5. STEF4S electrical characteristics

| Symbol | Parameter | Test conditions | Min. | Typ. | Max. | Unit |
|----------------------|---------------------------|--|------|------|------|--------------------|
| Total device | | | | | | |
| I_{Bias} | Bias current | ON state, $V_{EN} = V_{IN} = 5\text{ V}$ | | 50 | 65 | μA |
| | | OFF state, $V_{EN} = \text{GND}$, $V_{IN} = 5\text{ V}$ | | 15 | | |
| V_{min} | Minimum operating voltage | Device is in OFF state ($V_{OUT} = 0$) | 2 | | | V |
| Thermal latch | | | | | | |
| TSD | Shutdown temperature | | | 140 | | $^{\circ}\text{C}$ |
| | Hysteresis | | | 20 | | |

1. Guaranteed by design, not tested in production.

5 Typical characteristics

Figure 3. Application circuit

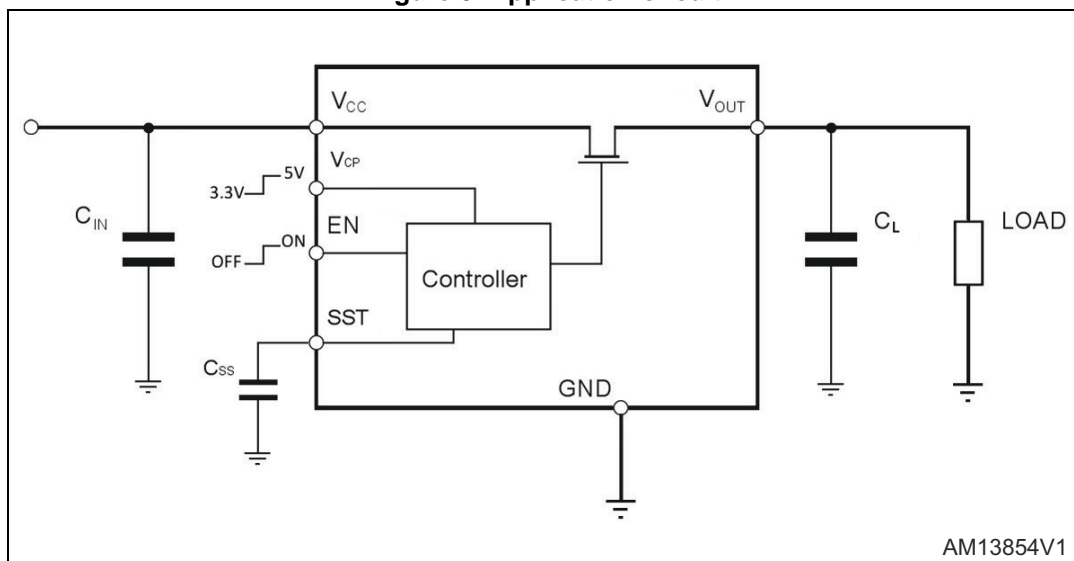

5.1 Operating modes

5.1.1 Turn-on

When the input voltage is applied and the EN pin is high, the output voltage is supplied with a slope defined by the internal dv/dt circuitry. If no additional capacitor is connected to C_{SS} pin, the total time from the enable signal going high and the output voltage reaching the nominal value is around 0.6 ms.

5.1.2 Normal operating condition

The STEF4S E-fuse behaves like a mechanical fuse, buffering the circuitry on its output with the same voltage shown at its input, apart from a small voltage fall due to the MOSFET R_{DS(on)}.

5.1.3 Output voltage clamp

The internal voltage clamp circuit clamps the output voltage to the V_{Clamp} values reported in [Table 5](#) if the input voltage exceeds the typical thresholds of 3.8 V in the 3.3 V mode and 5.7 V in the 5 V mode.

5.1.4 Current limiting

When an overload event occurs, the current limiting circuit reduces the conductivity of the power MOSFET, in order to clamp the input current at the pre-programmed value. The current limit circuit has a foldback characteristic to reduce the power dissipation over the power MOSFET in short-circuit condition.

5.1.5 Thermal shutdown and auto-retry function

If the device temperature exceeds the thermal shutdown threshold, typically 140 °C, the thermal shutdown circuitry turns the power MOSFET off and disconnects the load. Once the die temperature has decreased about 20 °C the device automatically attempts to apply again the power to the load (auto-retry). This cycle persists until the fault condition is removed.

5.2 Startup time and C_{SS} calculation

Connecting a capacitor between the C_{SS} pin and GND allows the modification of the output voltage startup time. The startup time (T_{SS}) is defined as the time interval between the device UVLO threshold, which has been overcome, and V_{OUT}, which has reached 90% of the nominal value as shown in [Figure 4](#).

The below [Table 6](#) shows the typical startup time obtained with the industry-standard values of C_{SS}.

Table 6. Startup time vs. C_{SS} capacitor value

| Parameter | Value | | | |
|----------------------|-------|-----|------|-----|
| C _{SS} [nF] | None | 10 | 47 | 100 |
| T _{SS} [ms] | 0.6 | 2.3 | 10.8 | 23 |

The capacitance to be added to C_{SS} pin can be also estimated by using the following theoretical formula:

Equation 1

$$C_{SS} = 4.35 \times 10^{-6} \times T_{SS}$$

The above value is not valid if C_{SS} is not connected. C_{SS} is expressed in Farad and the time in seconds.

A ceramic low leakage capacitor is suggested for this purpose. The formula is meant as a theoretical support to choose the C_{SS} capacitor and it does not take into account the capacitor tolerance, temperature and process variations.

Figure 4. Startup time

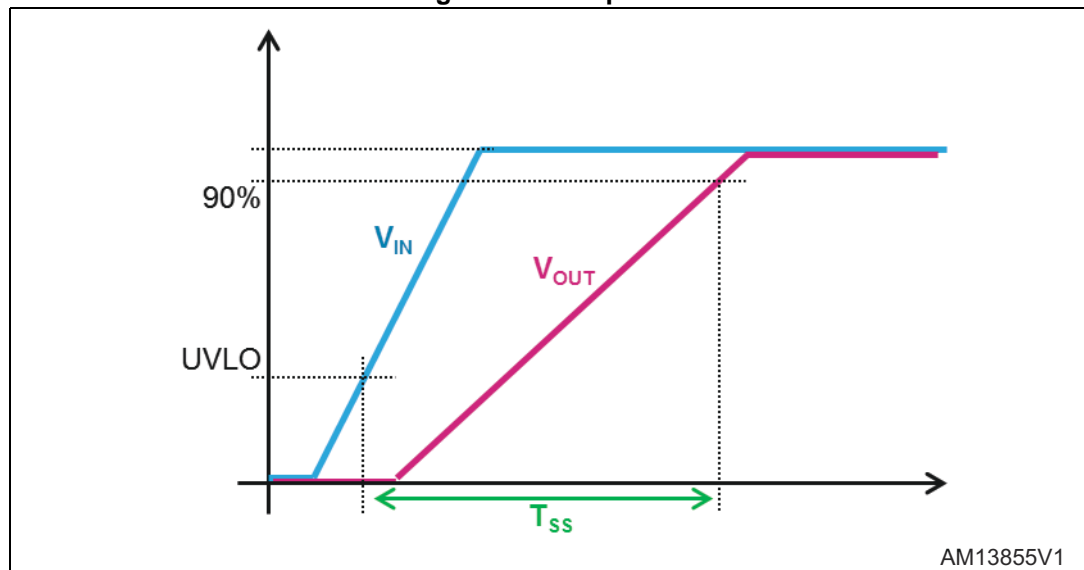

5.3 UVLO and voltage clamp selection

The device can be used either on the 3.3 V or on the 5 V lines. The operating mode can be selected through the V_{CP} pin.

If this pin is set at high level (V_{CP} > 2 V) the operating mode is 5 V. In this mode the UVLO threshold is 3.6 V typical, the clamping voltage is set to 5.7 V.

If the V_{CP} pin is pulled to low level (V_{CP} < 0.4 V), the operating mode is 3.3 V. In this mode the UVLO threshold is 2.3 V typical, the clamping voltage is set to 3.8 V.

5.4 Enable pin

The EN pin is used to turn on/off the device. The device is disabled when the EN pin voltage is lower than 0.4 V, enabled if the EN pin voltage is higher than 2 V.

6 Typical performance characteristics

(The following plots are referred to the typical application circuit and, unless otherwise noted, at $T_A = 25\text{ }^\circ\text{C}$)

Figure 5. $R_{DS(on)}$ vs temperature (3.3 V)

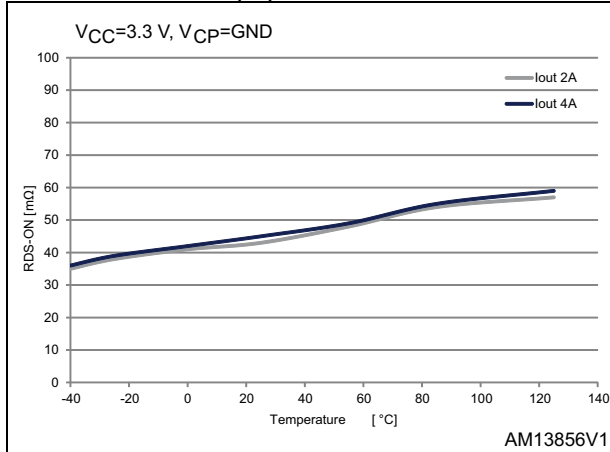

Figure 6. $R_{DS(on)}$ vs temperature (5 V)

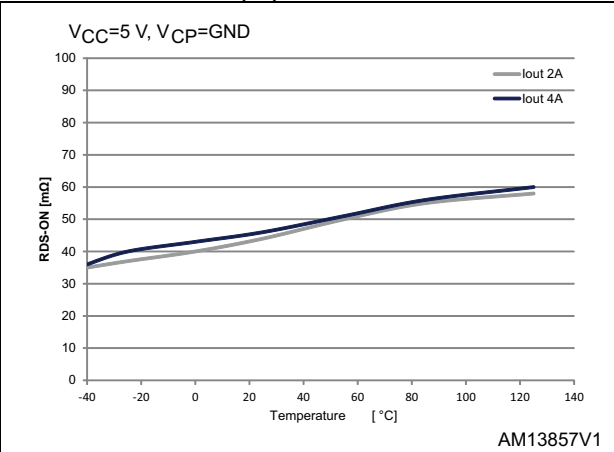

Figure 7. Clamping voltage vs temperature (3.3 V)

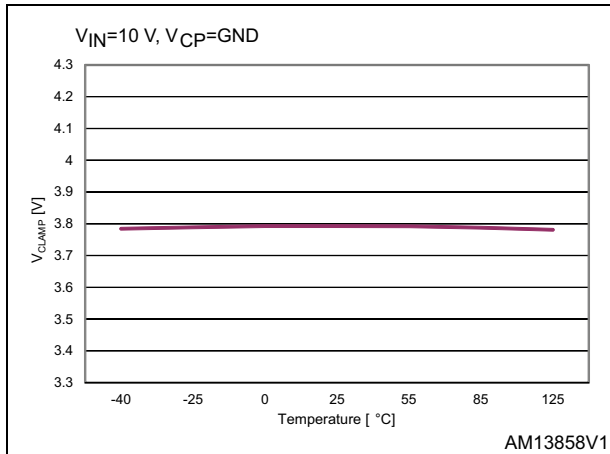

Figure 8. Clamping voltage vs temperature (5 V)

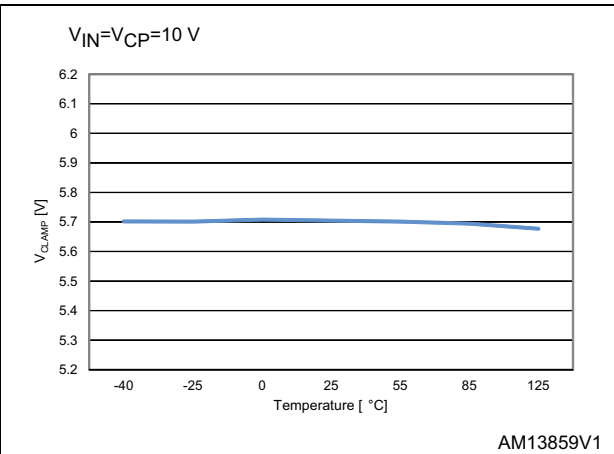

Figure 9. UVLO threshold vs temperature (3.3 V) Figure 10. UVLO threshold vs temperature (5 V)

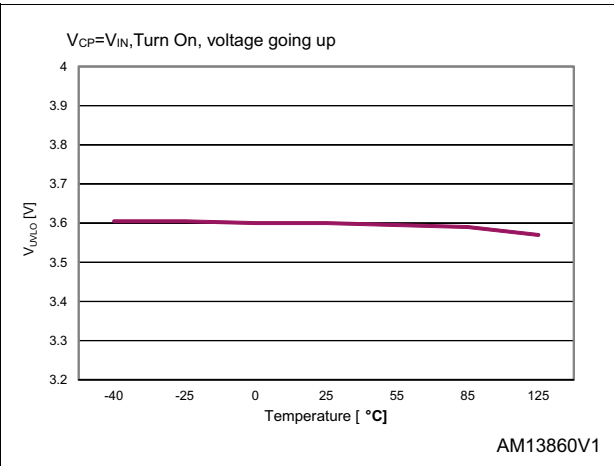
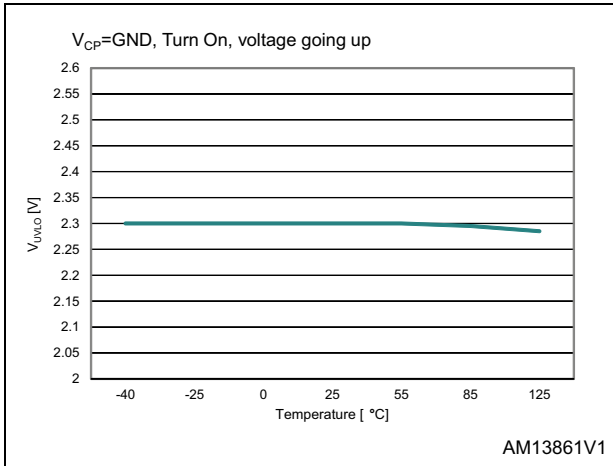

Figure 11. Bias current vs temperature (3.3 V)

Figure 12. Bias current vs temperature (5 V)

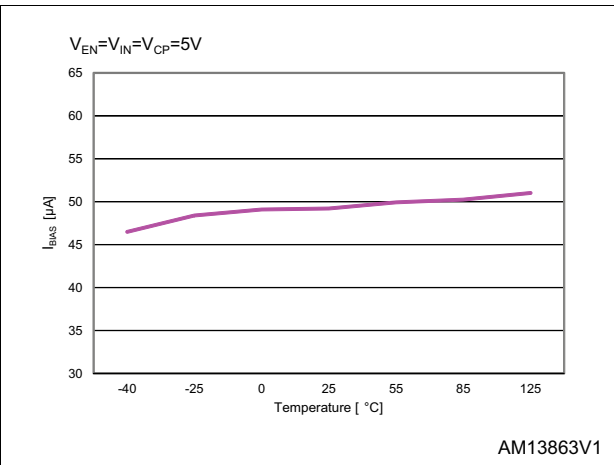
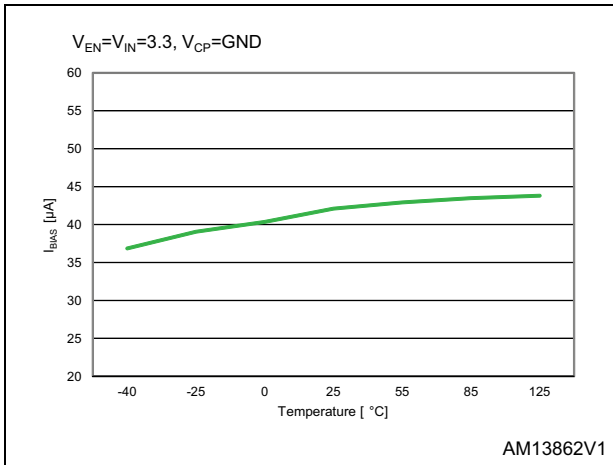

Figure 13. Shutdown current vs temperature (3.3 V)

Figure 14. Shutdown current vs temperature (5 V)

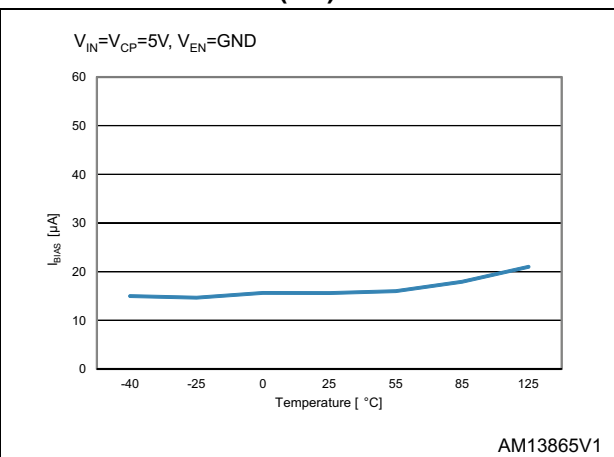
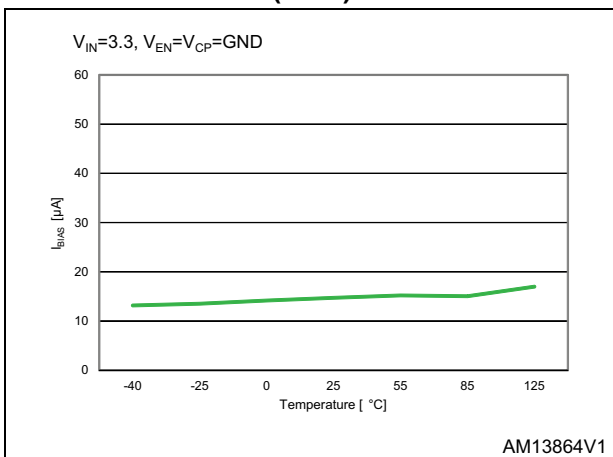

Figure 15. Trip point, overload and short-circuit current (3.3 V)

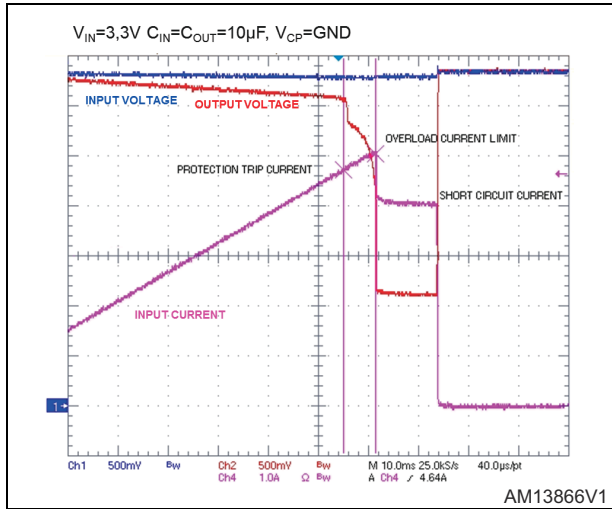

Figure 16. Trip point, overload and short-circuit current (5 V)

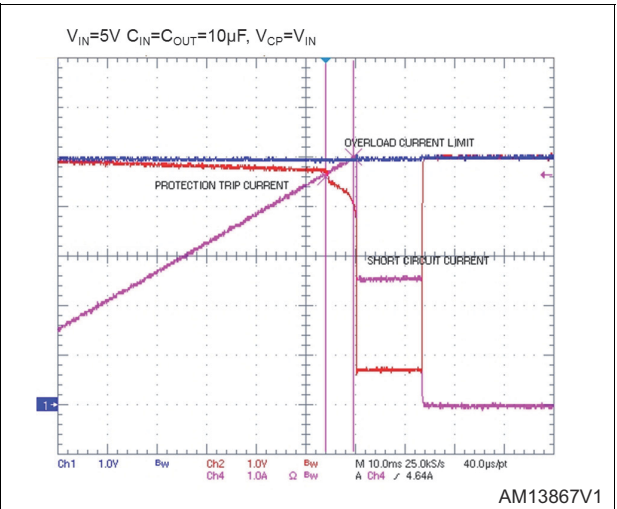

Figure 17. Startup into short-circuit (3.3 V)

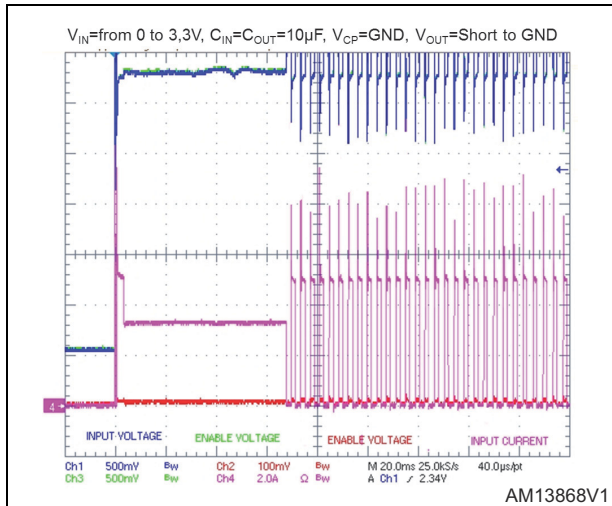

Figure 18. Startup into short-circuit (5 V)

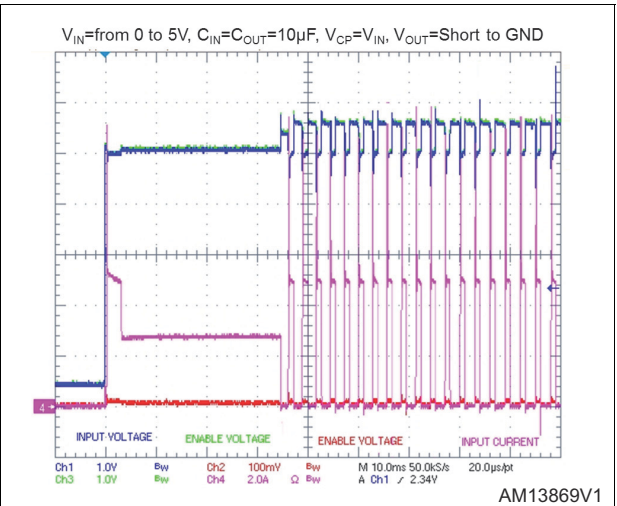

Figure 19. Soft-start behavior (3.3 V)

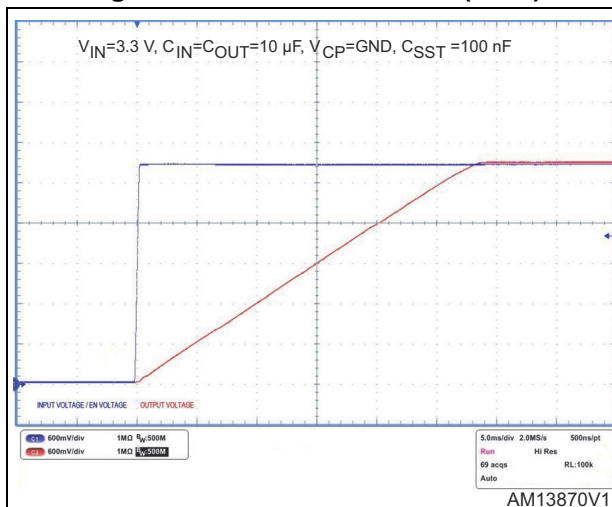
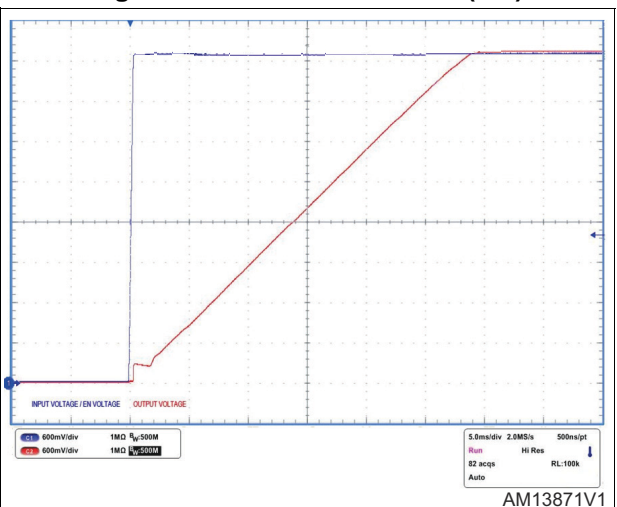

Figure 20. Soft-start behavior (5 V)



7 Package mechanical data

In order to meet environmental requirements, ST offers these devices in different grades of ECOPACK[®] packages, depending on their level of environmental compliance. ECOPACK[®] specifications, grade definitions and product status are available at: www.st.com. ECOPACK[®] is an ST trademark.

Table 7. DFN6 (3 x 3 mm) mechanical data

| Dim. | mm | | |
|------|-------|-------|-------|
| | Min. | Typ. | Max. |
| A | 0.70 | 0.75 | 0.80 |
| A1 | 0.00 | 0.02 | 0.05 |
| b | 0.18 | 0.25 | 0.30 |
| D | | 3.00 | |
| E | | 3.00 | |
| e | | 0.5 | |
| D2 | 2.234 | 2.384 | 2.484 |
| E2 | 1.496 | 1.646 | 1.746 |
| K | 0.20 | | |
| L | 0.30 | 0.40 | 0.50 |
| aaa | | 0.05 | |
| bbb | | 0.10 | |
| ccc | | 0.10 | |
| ddd | | 0.05 | |
| eee | | 0.08 | |

Figure 21. DFN6 (3 x 3 mm) drawings

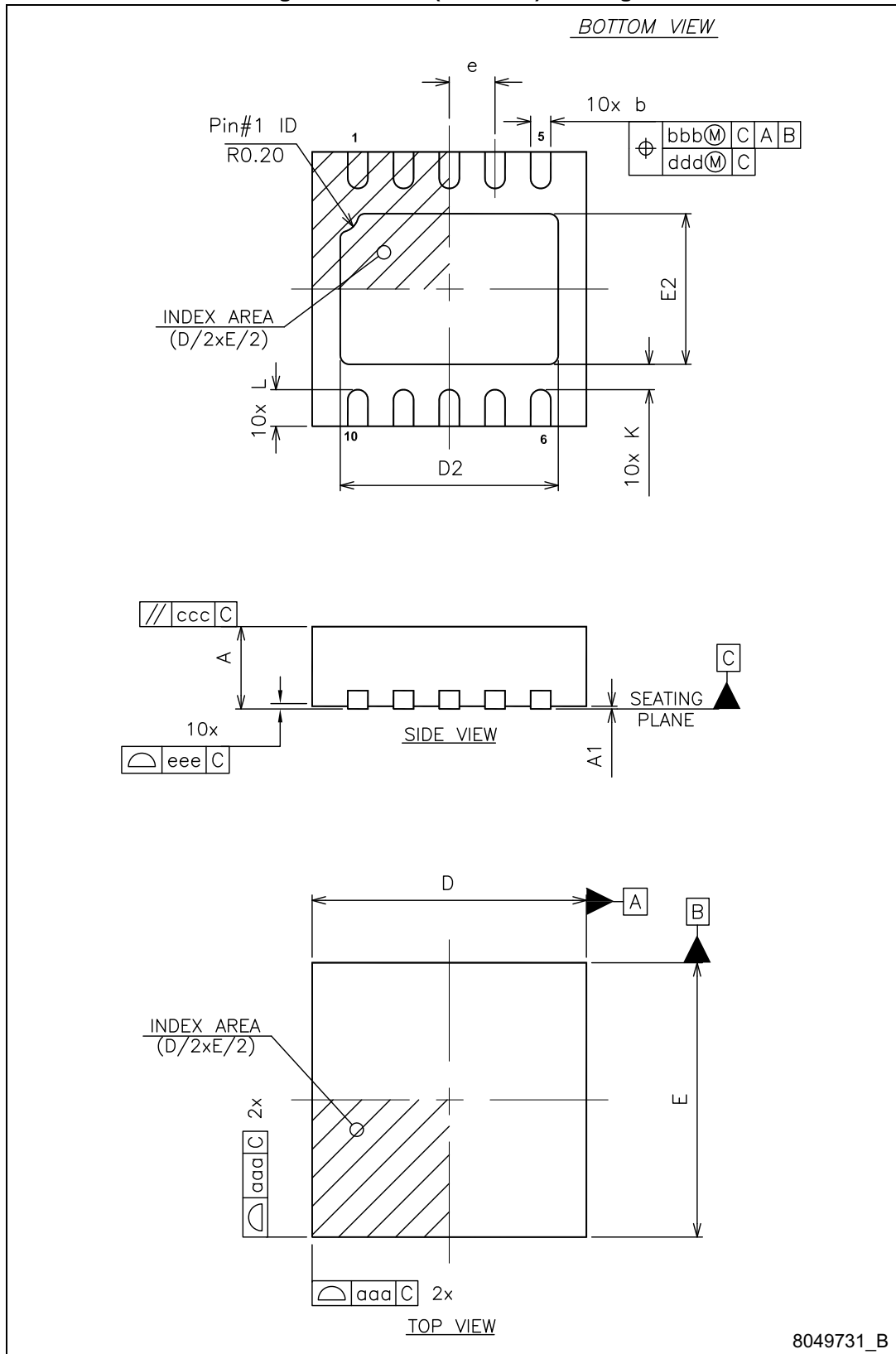
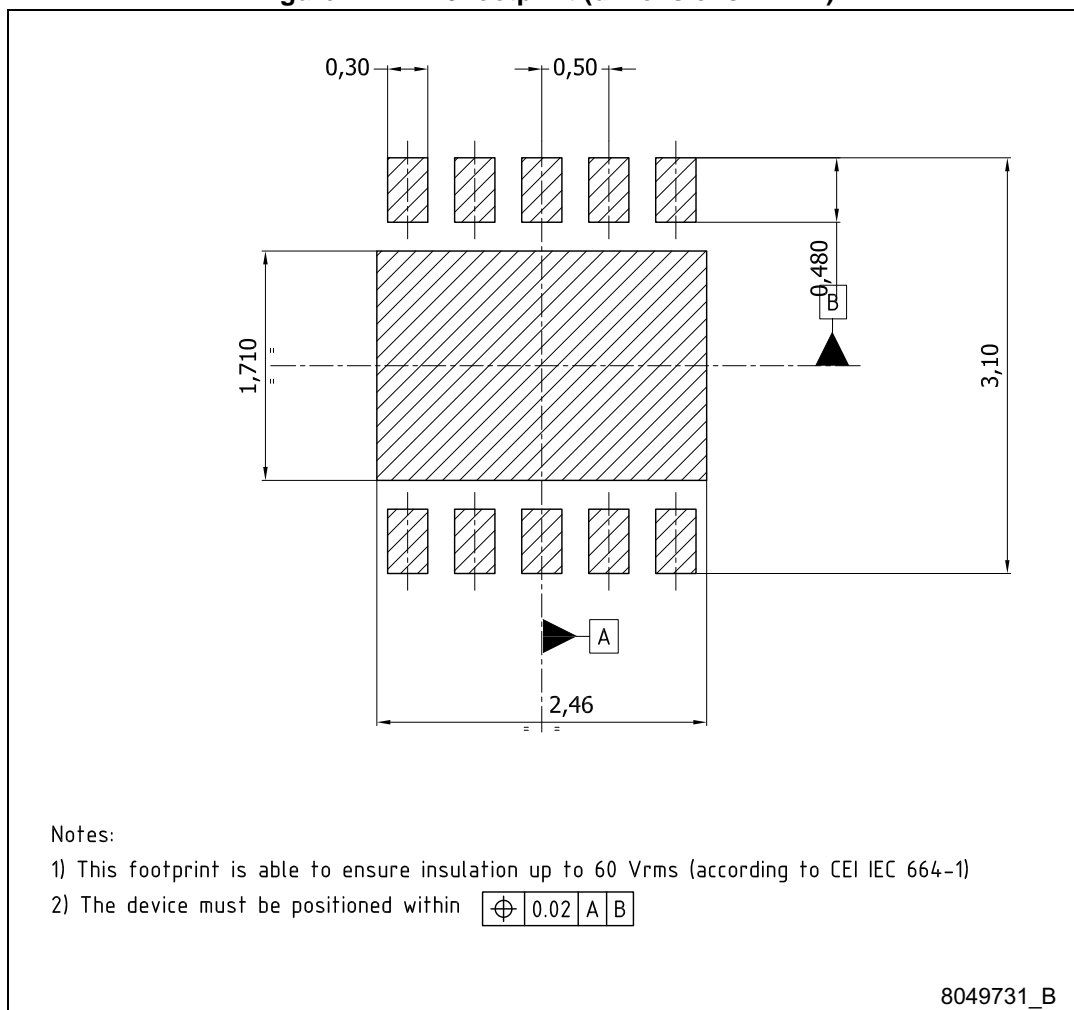

Figure 22. DFN6 footprint (dimensions in mm)



8 Packaging mechanical data

Table 8. DFN6 tape and reel mechanical data

| Dim. | mm | | |
|------|------|------|------|
| | Min. | Typ. | Max. |
| A0 | 3.20 | 3.30 | 3.40 |
| B0 | 3.20 | 3.30 | 3.40 |
| K0 | 1 | 1.10 | 1.20 |

Figure 23. Tape for DFN6

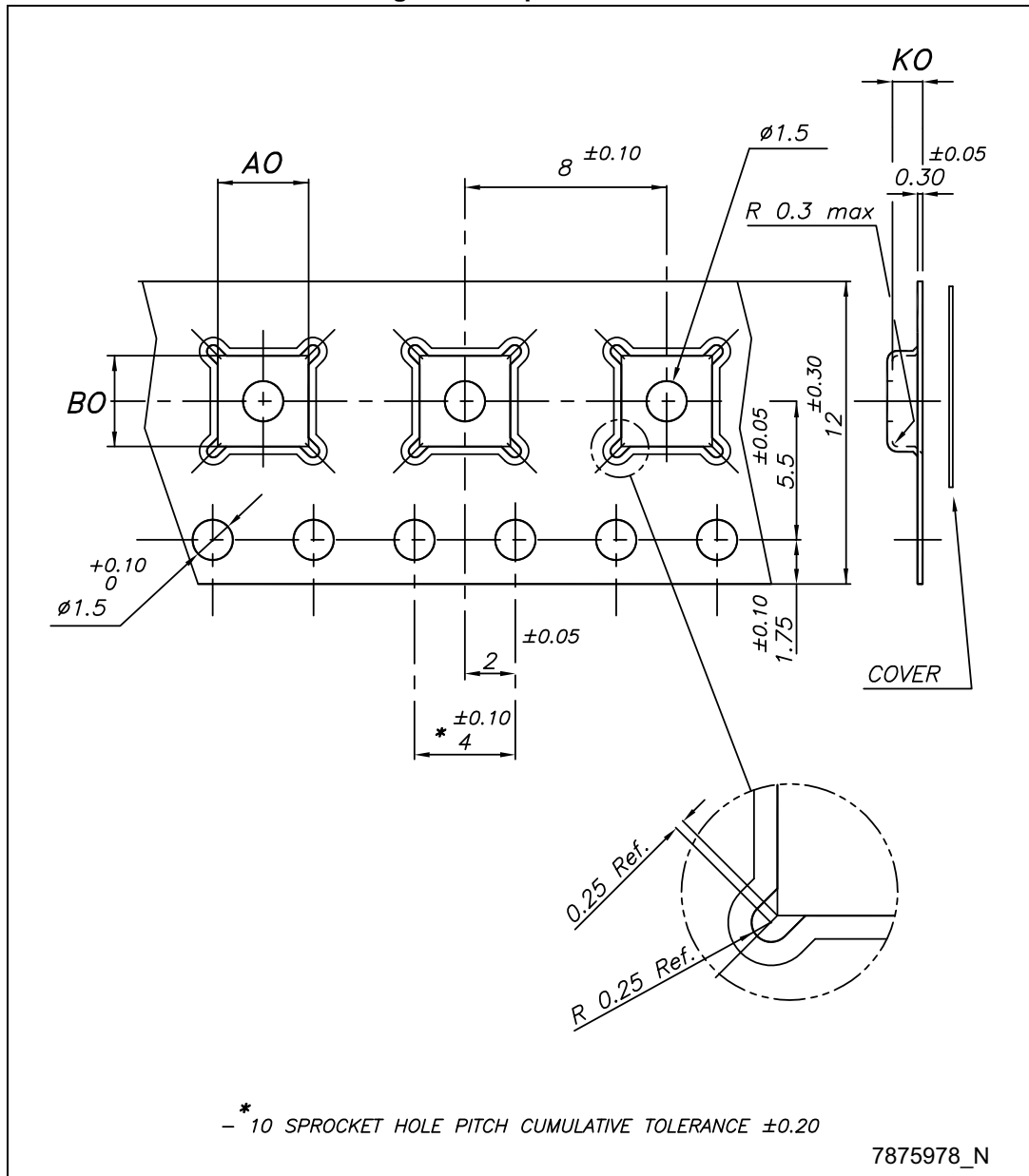

Figure 24. Reel for DFN6

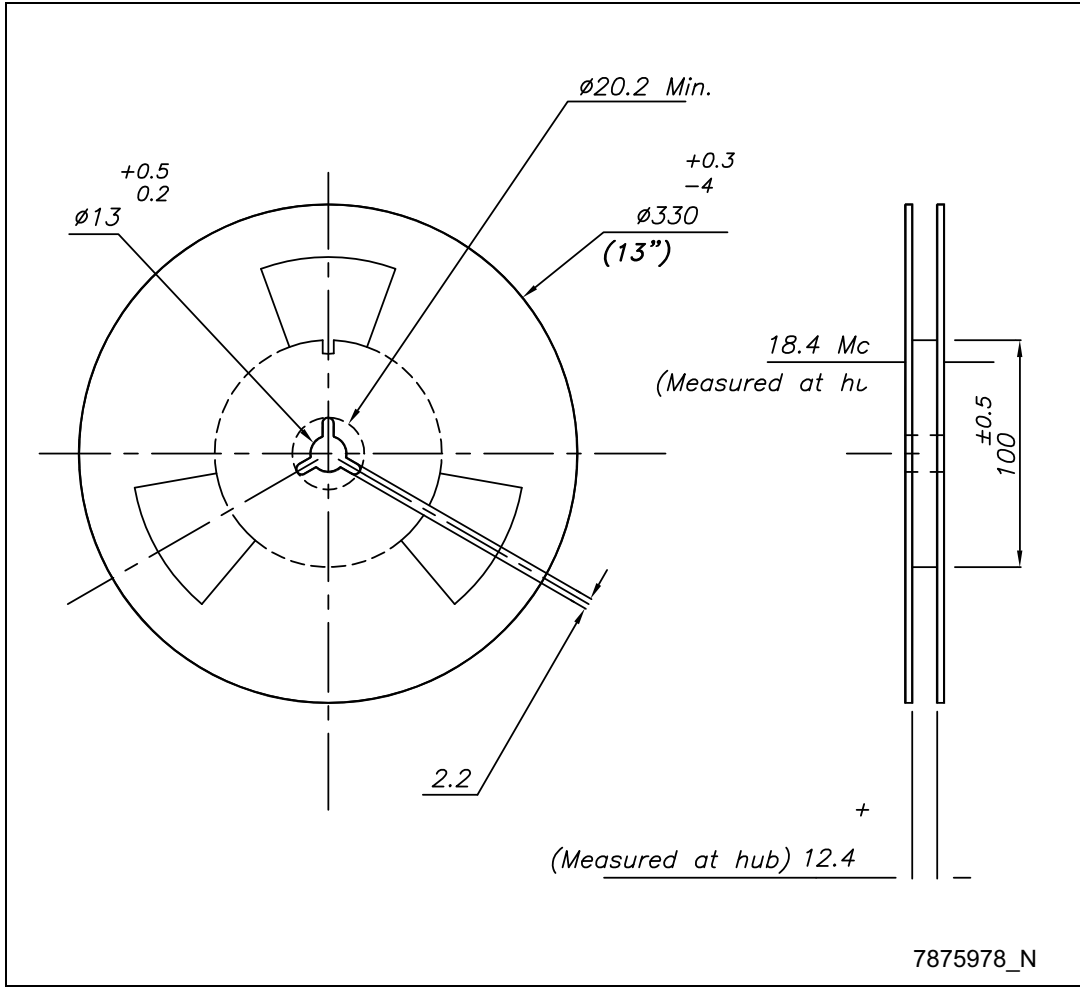
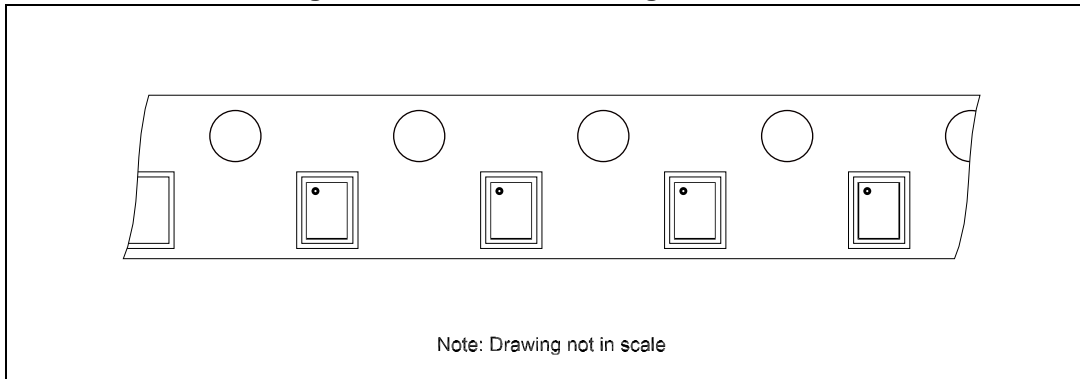

Figure 25. Schematic drawing orientation



9 Revision history

Table 9. Document revision history

| Date | Revision | Changes |
|-------------|----------|------------------|
| 23-Oct-2013 | 1 | Initial release. |

Please Read Carefully:

Information in this document is provided solely in connection with ST products. STMicroelectronics NV and its subsidiaries ("ST") reserve the right to make changes, corrections, modifications or improvements, to this document, and the products and services described herein at any time, without notice.

All ST products are sold pursuant to ST's terms and conditions of sale.

Purchasers are solely responsible for the choice, selection and use of the ST products and services described herein, and ST assumes no liability whatsoever relating to the choice, selection or use of the ST products and services described herein.

No license, express or implied, by estoppel or otherwise, to any intellectual property rights is granted under this document. If any part of this document refers to any third party products or services it shall not be deemed a license grant by ST for the use of such third party products or services, or any intellectual property contained therein or considered as a warranty covering the use in any manner whatsoever of such third party products or services or any intellectual property contained therein.

UNLESS OTHERWISE SET FORTH IN ST'S TERMS AND CONDITIONS OF SALE ST DISCLAIMS ANY EXPRESS OR IMPLIED WARRANTY WITH RESPECT TO THE USE AND/OR SALE OF ST PRODUCTS INCLUDING WITHOUT LIMITATION IMPLIED WARRANTIES OF MERCHANTABILITY, FITNESS FOR A PARTICULAR PURPOSE (AND THEIR EQUIVALENTS UNDER THE LAWS OF ANY JURISDICTION), OR INFRINGEMENT OF ANY PATENT, COPYRIGHT OR OTHER INTELLECTUAL PROPERTY RIGHT.

ST PRODUCTS ARE NOT DESIGNED OR AUTHORIZED FOR USE IN: (A) SAFETY CRITICAL APPLICATIONS SUCH AS LIFE SUPPORTING, ACTIVE IMPLANTED DEVICES OR SYSTEMS WITH PRODUCT FUNCTIONAL SAFETY REQUIREMENTS; (B) AERONAUTIC APPLICATIONS; (C) AUTOMOTIVE APPLICATIONS OR ENVIRONMENTS, AND/OR (D) AEROSPACE APPLICATIONS OR ENVIRONMENTS. WHERE ST PRODUCTS ARE NOT DESIGNED FOR SUCH USE, THE PURCHASER SHALL USE PRODUCTS AT PURCHASER'S SOLE RISK, EVEN IF ST HAS BEEN INFORMED IN WRITING OF SUCH USAGE, UNLESS A PRODUCT IS EXPRESSLY DESIGNATED BY ST AS BEING INTENDED FOR "AUTOMOTIVE, AUTOMOTIVE SAFETY OR MEDICAL" INDUSTRY DOMAINS ACCORDING TO ST PRODUCT DESIGN SPECIFICATIONS. PRODUCTS FORMALLY ESCC, QML OR JAN QUALIFIED ARE DEEMED SUITABLE FOR USE IN AEROSPACE BY THE CORRESPONDING GOVERNMENTAL AGENCY.

Resale of ST products with provisions different from the statements and/or technical features set forth in this document shall immediately void any warranty granted by ST for the ST product or service described herein and shall not create or extend in any manner whatsoever, any liability of ST.

ST and the ST logo are trademarks or registered trademarks of ST in various countries.

Information in this document supersedes and replaces all information previously supplied.

The ST logo is a registered trademark of STMicroelectronics. All other names are the property of their respective owners.

© 2013 STMicroelectronics - All rights reserved

STMicroelectronics group of companies

Australia - Belgium - Brazil - Canada - China - Czech Republic - Finland - France - Germany - Hong Kong - India - Israel - Italy - Japan - Malaysia - Malta - Morocco - Philippines - Singapore - Spain - Sweden - Switzerland - United Kingdom - United States of America

www.st.com