



# STD45NF75

## N-CHANNEL 75V - 0.018 Ω -40A DPAK STripFET™ II POWER MOSFET

TYPE	V <sub>DSS</sub>	R <sub>DS(on)</sub>	I <sub>D</sub>
STD45NF75	75 V	<0.024 Ω	40 A(**)

- TYPICAL R<sub>DS(on)</sub> = 0.018 Ω
- 100% AVALANCHE TESTED
- GATE CHARGE MINIMIZED
- SURFACE-MOUNTING DPAK (TO-252)  
POWER PACKAGE IN TAPE & REEL  
(SUFFIX "T4")

### DESCRIPTION

This Power MOSFET is the latest development of STMicroelectronics unique "Single Feature Size™" strip-based process. The resulting transistor shows extremely high packing density for low on-resistance, rugged avalanche characteristics and less critical alignment steps therefore a remarkable manufacturing reproducibility.

### APPLICATIONS

- HIGH CURRENT, SWITCHING APPLICATIONS

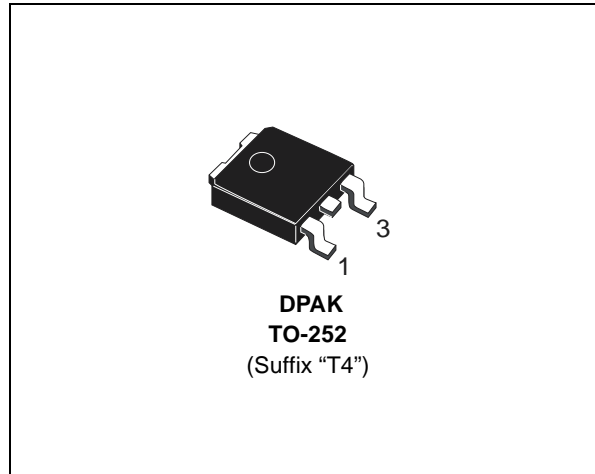

### INTERNAL SCHEMATIC DIAGRAM

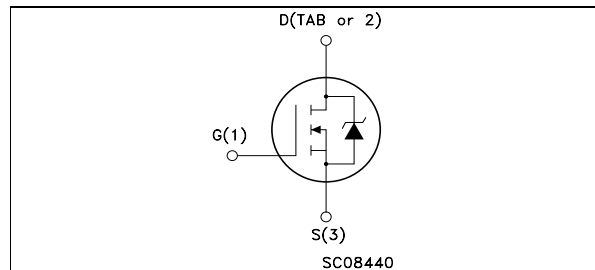

### Ordering Information

SALES TYPE	MARKING	PACKAGE	PACKAGING
STD45NF75T4	D45NF75	DPAK	TAPE & REEL

### ABSOLUTE MAXIMUM RATINGS

Symbol	Parameter	Value	Unit
V <sub>DS</sub>	Drain-source Voltage (V <sub>GS</sub> = 0)	75	V
V <sub>DGR</sub>	Drain-gate Voltage (R <sub>GS</sub> = 20 kΩ)	75	V
V <sub>GS</sub>	Gate- source Voltage	± 20	V
I <sub>D(**)</sub>	Drain Current (continuous) at T <sub>C</sub> = 25°C	40	A
I <sub>D</sub>	Drain Current (continuous) at T <sub>C</sub> = 100°C	30	A
I <sub>DM(●)</sub>	Drain Current (pulsed)	160	A
P <sub>tot</sub>	Total Dissipation at T <sub>C</sub> = 25°C	100	W
	Derating Factor	0.67	W/°C
dv/dt (1)	Peak Diode Recovery voltage slope	20	V/ns
E <sub>AS</sub> (2)	Single Pulse Avalanche Energy	500	mJ
T <sub>stg</sub>	Storage Temperature	-55 to 175	°C
T <sub>j</sub>	Operating Junction Temperature		

(●) Pulse width limited by safe operating area.

(\*\*) Current Limited by Package

(1) I<sub>SD</sub> ≤ 40A, di/dt ≤ 800A/μs, V<sub>DD</sub> ≤ V<sub>(BR)DSS</sub>, T<sub>j</sub> ≤ T<sub>JMAX</sub>

(2) Starting T<sub>j</sub> = 25 °C, I<sub>D</sub> = 20 A, V<sub>DD</sub> = 40V

# STD45NF75

## THERMAL DATA

Rthj-case	Thermal Resistance Junction-case	Max	1.5	°C/W
Rthj-pcb	Thermal Resistance Junction-pcb	Max	see curve on page 6	°C/W
T <sub>l</sub>	Maximum Lead Temperature For Soldering Purpose (for 10 sec. 1.6 mm from case)		275	°C

## ELECTRICAL CHARACTERISTICS (T<sub>case</sub> = 25 °C unless otherwise specified)

### OFF

Symbol	Parameter	Test Conditions	Min.	Typ.	Max.	Unit
V <sub>(BR)DSS</sub>	Drain-source Breakdown Voltage	I <sub>D</sub> = 250 μA V <sub>GS</sub> = 0	75			V
I <sub>DSS</sub>	Zero Gate Voltage Drain Current (V <sub>GS</sub> = 0)	V <sub>DS</sub> = Max Rating V <sub>DS</sub> = Max Rating T <sub>C</sub> = 125°C			1 10	μA μA
I <sub>GSS</sub>	Gate-body Leakage Current (V <sub>DS</sub> = 0)	V <sub>GS</sub> = ± 20 V			±100	nA

### ON (\*)

Symbol	Parameter	Test Conditions	Min.	Typ.	Max.	Unit
V <sub>GS(th)</sub>	Gate Threshold Voltage	V <sub>DS</sub> = V <sub>GS</sub> I <sub>D</sub> = 250 μA	2		4	V
R <sub>DS(on)</sub>	Static Drain-source On Resistance	V <sub>GS</sub> = 10 V I <sub>D</sub> = 20 A		0.018	0.024	Ω

### DYNAMIC

Symbol	Parameter	Test Conditions	Min.	Typ.	Max.	Unit
g <sub>fs</sub> (*)	Forward Transconductance	V <sub>DS</sub> = 25 V I <sub>D</sub> = 20 A		50		S
C <sub>iss</sub> C <sub>oss</sub> C <sub>rss</sub>	Input Capacitance Output Capacitance Reverse Transfer Capacitance	V <sub>DS</sub> = 25V, f = 1 MHz, V <sub>GS</sub> = 0		1760 360 140		pF pF pF

**ELECTRICAL CHARACTERISTICS** (continued)

**SWITCHING ON**

Symbol	Parameter	Test Conditions	Min.	Typ.	Max.	Unit
$t_{d(on)}$ $t_r$	Turn-on Delay Time Rise Time	$V_{DD} = 37\text{ V}$ $I_D = 20\text{ A}$ $R_G = 4.7\ \Omega$ $V_{GS} = 10\text{ V}$ (Resistive Load, Figure 3)		15 40		ns ns
$Q_g$ $Q_{gs}$ $Q_{gd}$	Total Gate Charge Gate-Source Charge Gate-Drain Charge	$V_{DD}=60\text{ V}$ $I_D=40\text{ A}$ $V_{GS}= 10\text{ V}$ (see test circuit, Figure 4)		60 13 23	80	nC nC nC

**SWITCHING OFF**

Symbol	Parameter	Test Conditions	Min.	Typ.	Max.	Unit
$t_{d(off)}$ $t_f$	Turn-off Delay Time Fall Time	$V_{DD} = 37\text{ V}$ $I_D = 20\text{ A}$ $R_G = 4.7\ \Omega$ , $V_{GS} = 10\text{ V}$ (Resistive Load, Figure 3)		55 12		ns ns

**SOURCE DRAIN DIODE**

Symbol	Parameter	Test Conditions	Min.	Typ.	Max.	Unit
$I_{SD}$ $I_{SDM} (\bullet)$	Source-drain Current Source-drain Current (pulsed)				40 160	A A
$V_{SD} (^*)$	Forward On Voltage	$I_{SD} = 40\text{ A}$ $V_{GS} = 0$			1.5	V
$t_{rr}$ $Q_{rr}$ $I_{RRM}$	Reverse Recovery Time Reverse Recovery Charge Reverse Recovery Current	$I_{SD} = 40\text{ A}$ $di/dt = 100\text{ A}/\mu\text{s}$ $V_{DD} = 30\text{ V}$ $T_j = 150^\circ\text{C}$ (see test circuit, Figure 5)		120 410 7.5		ns nC A

(\*)Pulsed: Pulse duration = 300  $\mu\text{s}$ , duty cycle 1.5 %.

(•)Pulse width limited by safe operating area.

**Safe Operating Area**

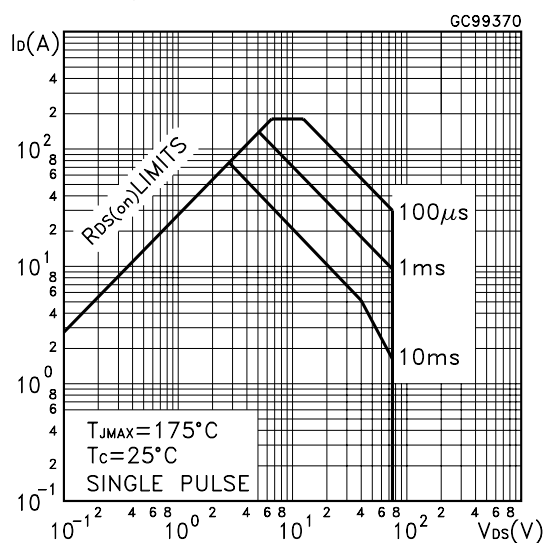

**Thermal Impedance**

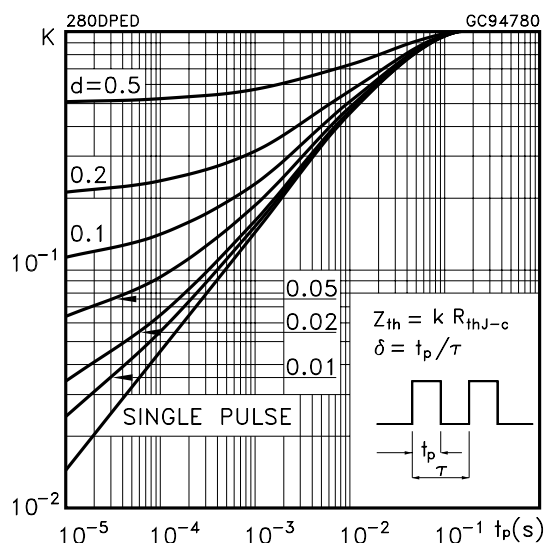

# STD45NF75

Output Characteristics

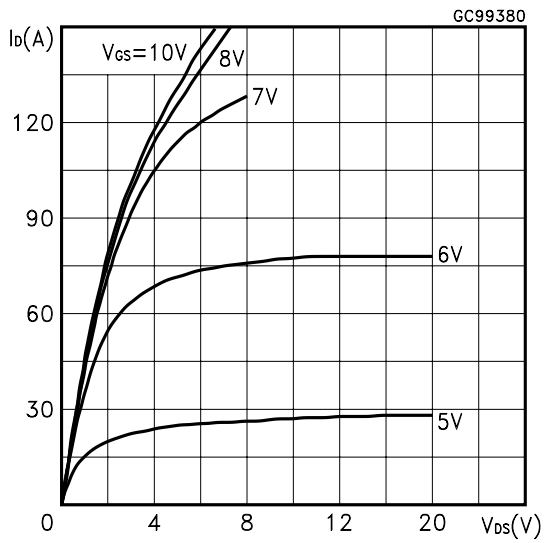

Transfer Characteristics

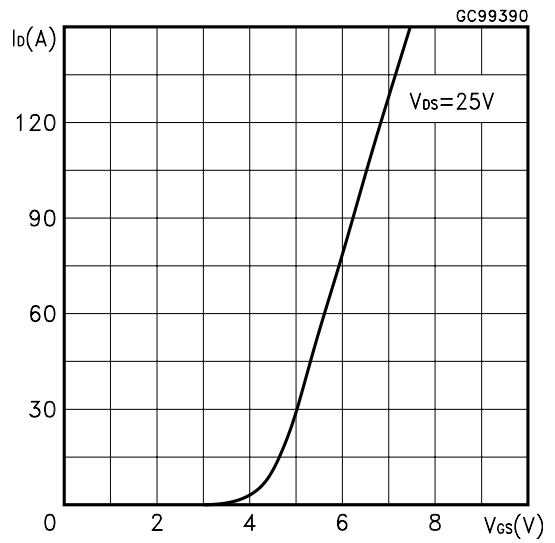

Transconductance

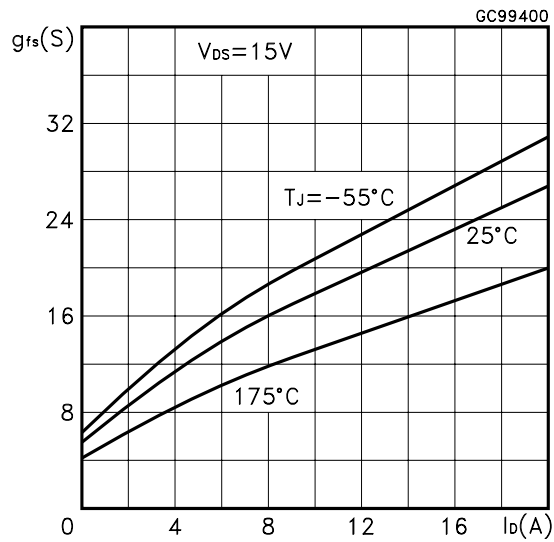

Static Drain-source On Resistance

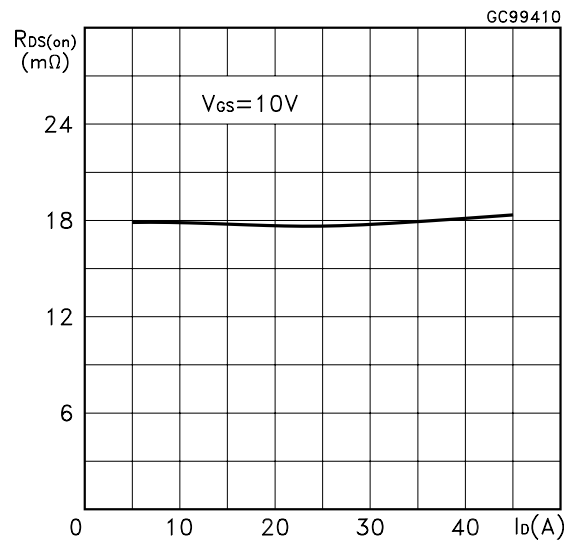

Gate Charge vs Gate-source Voltage

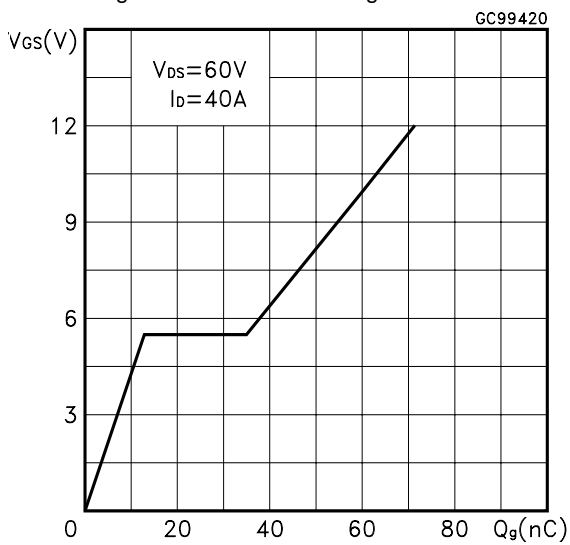

Capacitance Variations

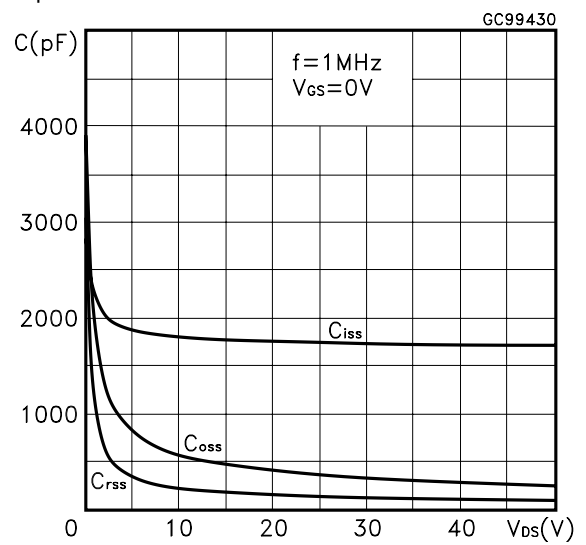

Normalized Gate Threshold Voltage vs Temperature

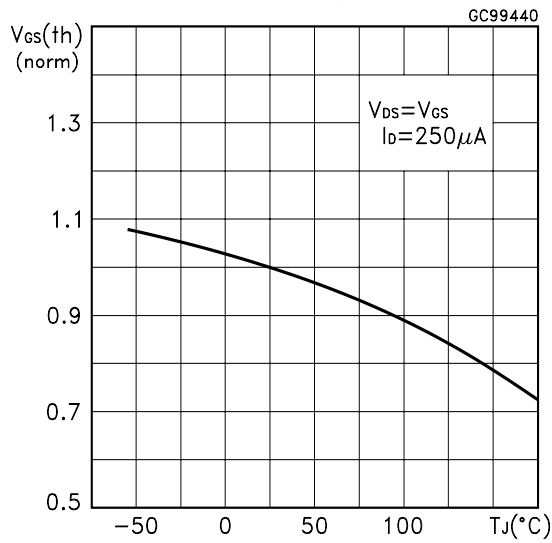

Normalized on Resistance vs Temperature

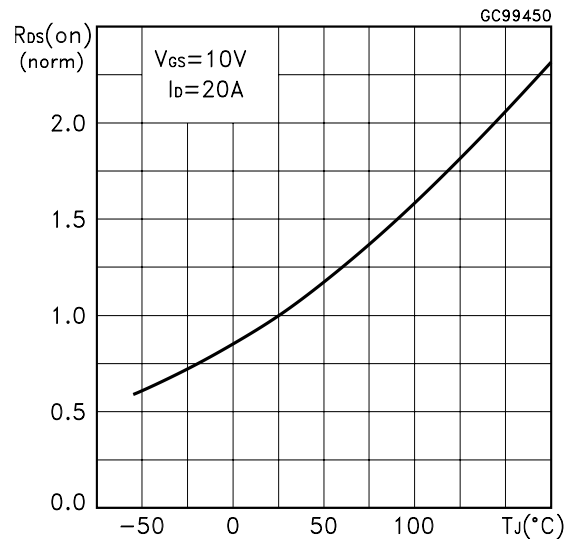

Source-drain Diode Forward Characteristics

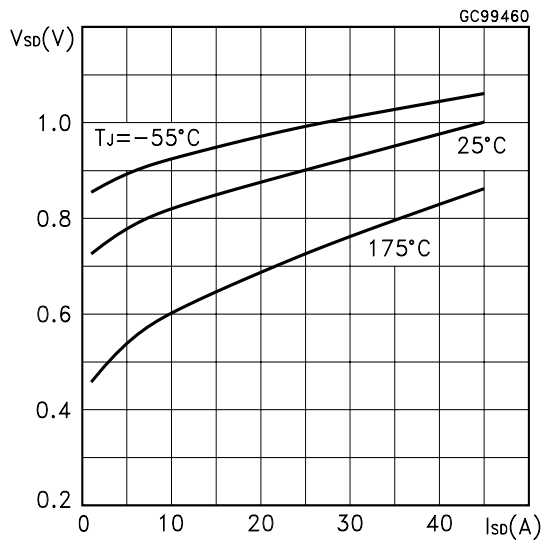

Normalized Breakdown Voltage vs Temperature.

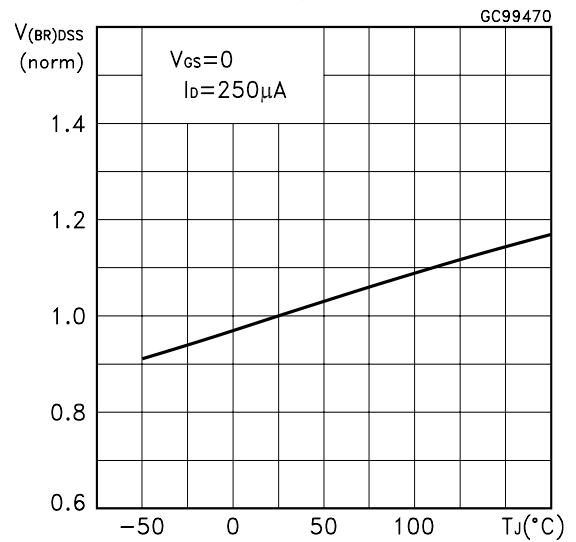

Power Derating vs Tc

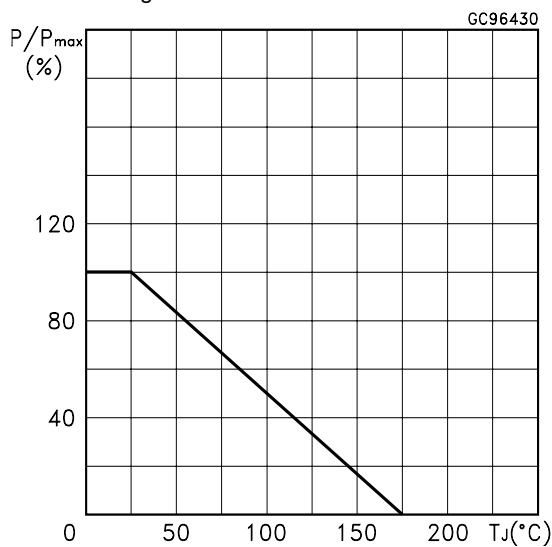

Max Id Current vs Tc.

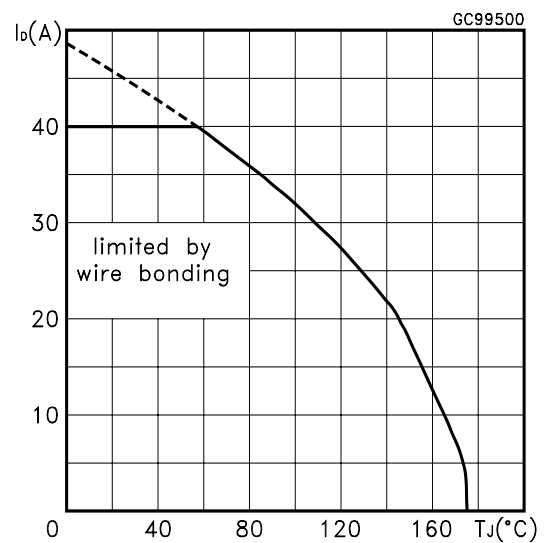

# STD45NF75

Thermal Resistance Rthj-a vs PCB Copper Area

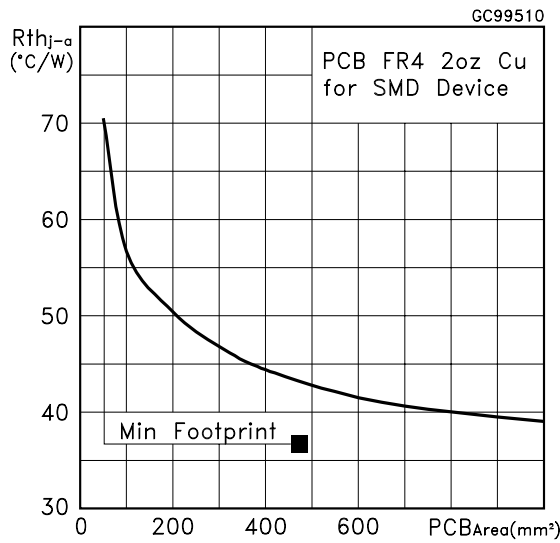

Max Power Dissipation vs PCB Copper Area

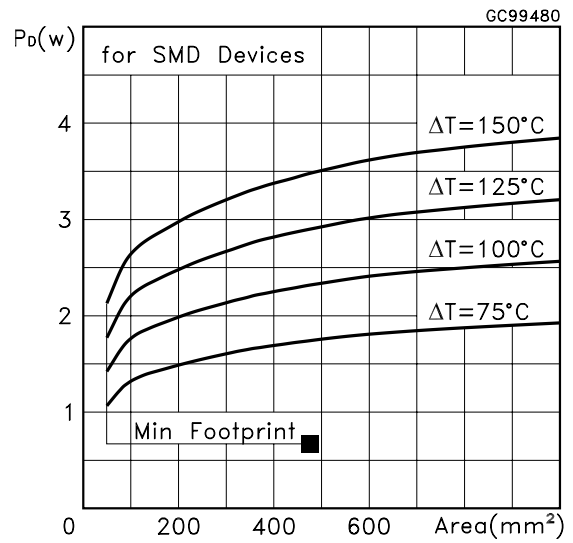

## Allowable Iav vs. Time in Avalanche

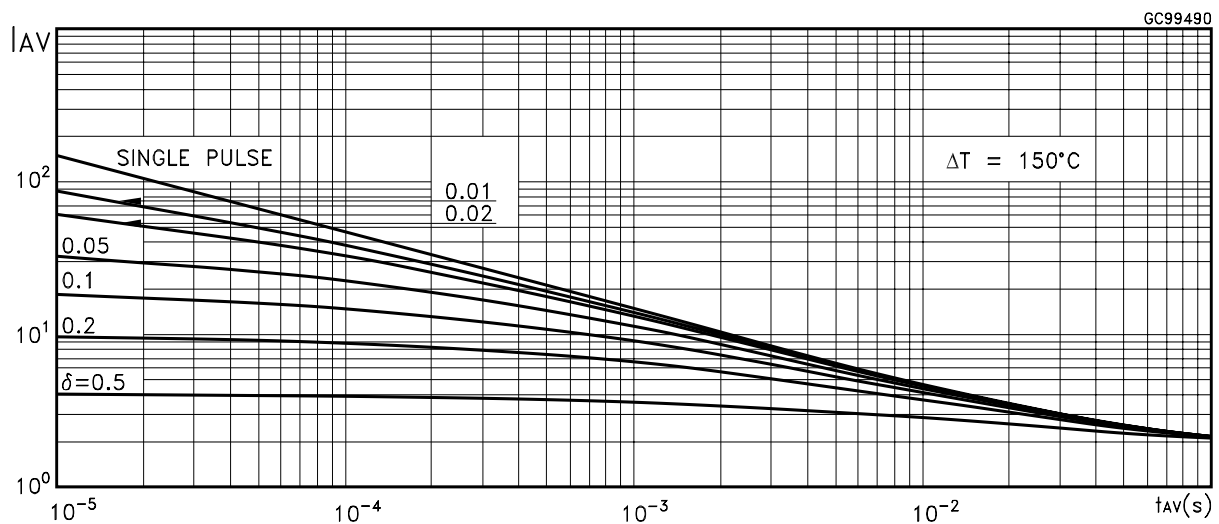

The previous curve gives the safe operating area for unclamped inductive loads, single pulse or repetitive, under the following conditions:

$$P_{D(AVE)} = 0.5 * (1.3 * BV_{DSS} * I_{AV})$$

$$E_{AS(AR)} = P_{D(AVE)} * t_{AV}$$

Where:

- $I_{AV}$  is the Allowable Current in Avalanche
- $P_{D(AVE)}$  is the Average Power Dissipation in Avalanche (Single Pulse)
- $t_{AV}$  is the Time in Avalanche

To derate above 25 °C, at fixed  $I_{AV}$ , the following equation must be applied:

$$I_{AV} = 2 * (T_{jmax} - T_{CASE}) / (1.3 * BV_{DSS} * Z_{th})$$

Where:

$Z_{th} = K * R_{th}$  is the value coming from Normalized Thermal Response at fixed pulse width equal to  $T_{AV}$ .



**SPICE THERMAL MODEL**

Parameter	Node	Value
CTHERM1	7 - 6	$6 * 10^{-4}$
CTHERM2	6 - 5	$8 * 10^{-3}$
CTHERM3	5 - 4	$2 * 10^{-2}$
CTHERM4	4 - 3	$6 * 10^{-2}$
CTHERM5	3 - 2	$9.65 * 10^{-2}$
CTHERM6	2 - 1	$6 * 10^{-1}$
R THERM1	7 - 6	0.045
R THERM2	6 - 5	0.105
R THERM3	5 - 4	0.150
R THERM4	4 - 3	0.225
R THERM5	3 - 2	0.375
R THERM6	2 - 1	0.600

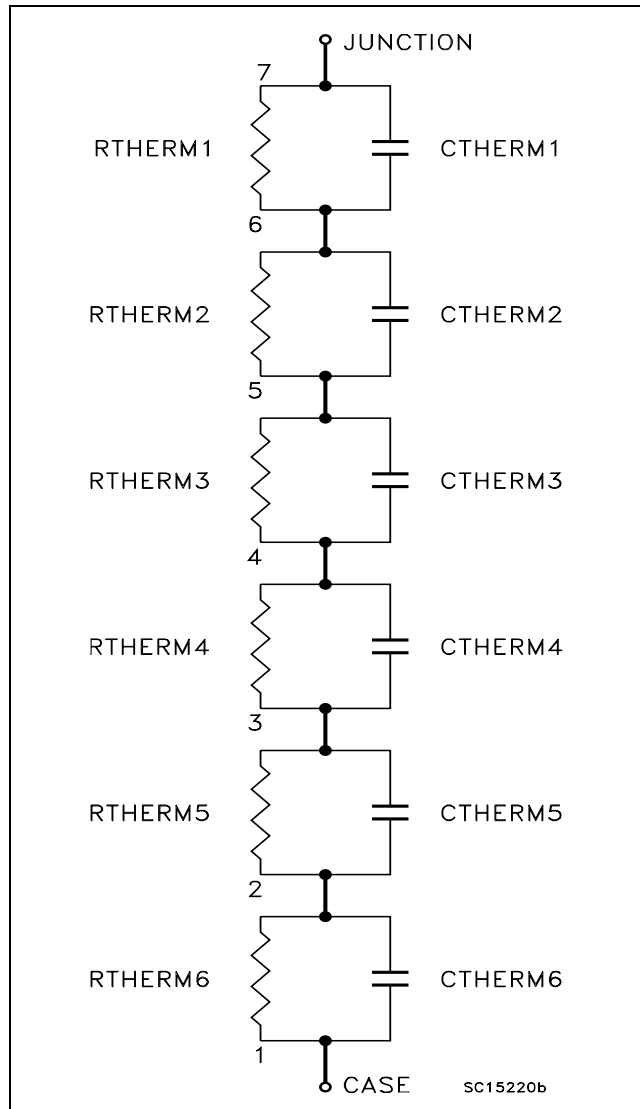

Fig. 1: Unclamped Inductive Load Test Circuit

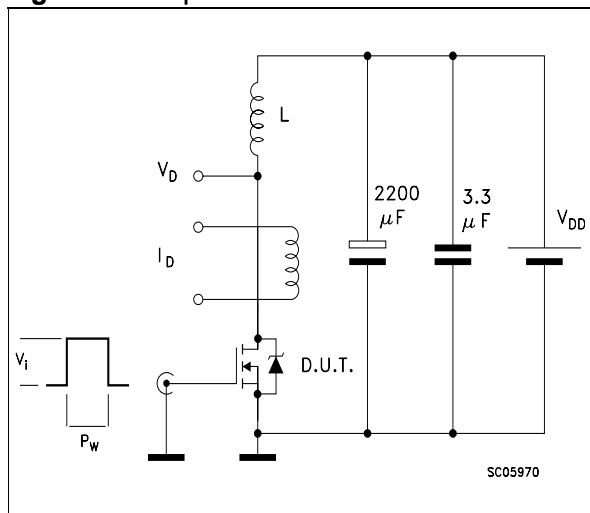

Fig. 2: Unclamped Inductive Waveform

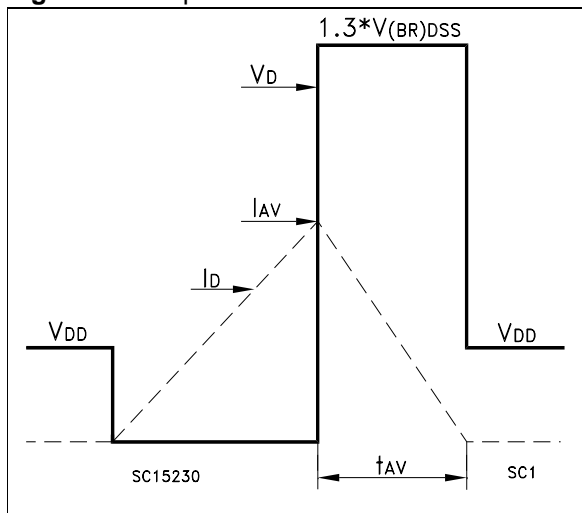

Fig. 3: Switching Times Test Circuits For Resistive Load

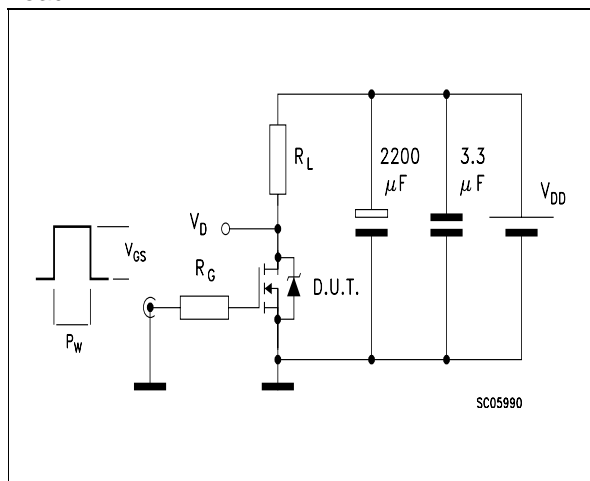

Fig. 3.1: Switching Time Waveform

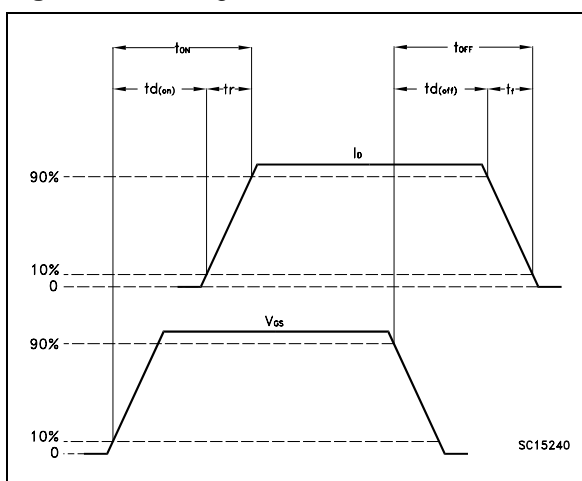

Fig. 4: Gate Charge Test Circuit

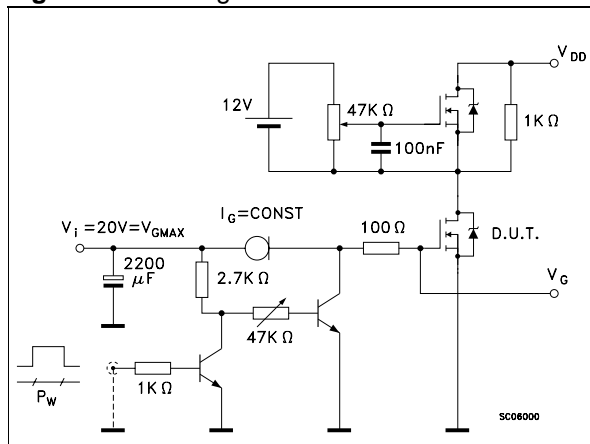

Fig. 4.1: Gate Charge Test Waveform

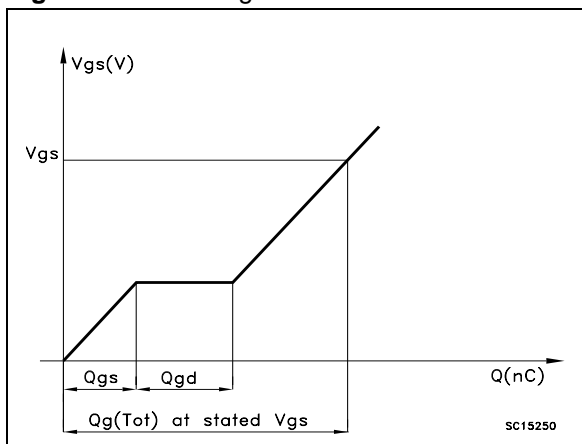



Fig. 5: Diode Switching Test Circuit

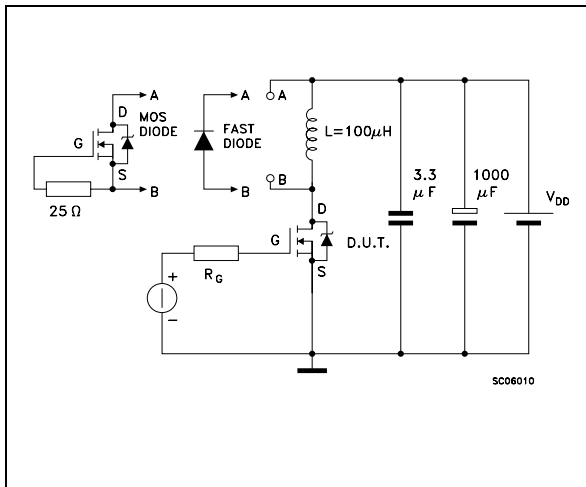
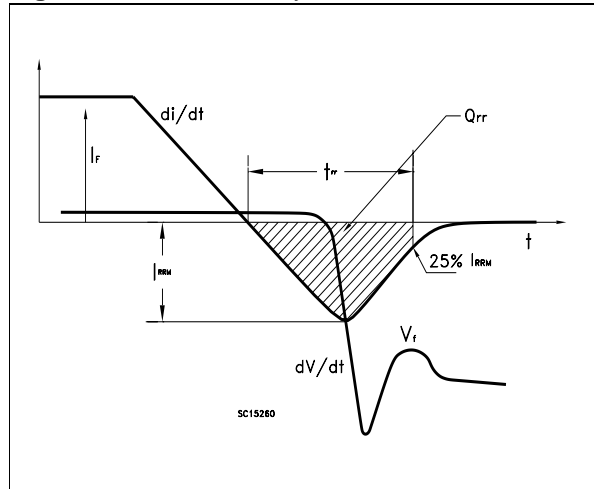
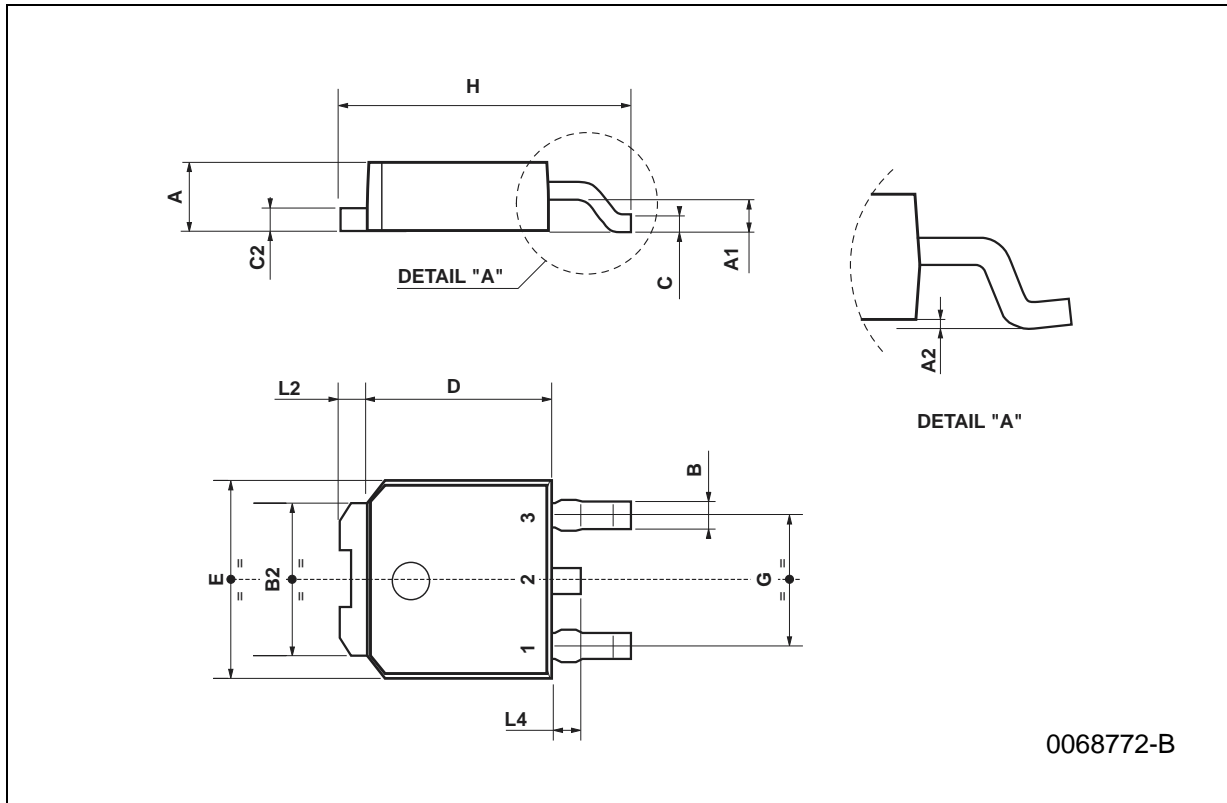

Fig. 5.1: Diode Recovery Times Waveform



**TO-252 (DPAK) MECHANICAL DATA**

DIM.	mm			inch		
	MIN.	TYP.	MAX.	MIN.	TYP.	MAX.
A	2.2		2.4	0.086		0.094
A1	0.9		1.1	0.035		0.043
A2	0.03		0.23	0.001		0.009
B	0.64		0.9	0.025		0.035
B2	5.2		5.4	0.204		0.212
C	0.45		0.6	0.017		0.023
C2	0.48		0.6	0.019		0.023
D	6		6.2	0.236		0.244
E	6.4		6.6	0.252		0.260
G	4.4		4.6	0.173		0.181
H	9.35		10.1	0.368		0.397
L2		0.8			0.031	
L4	0.6		1	0.023		0.039



**DPAK FOOTPRINT**

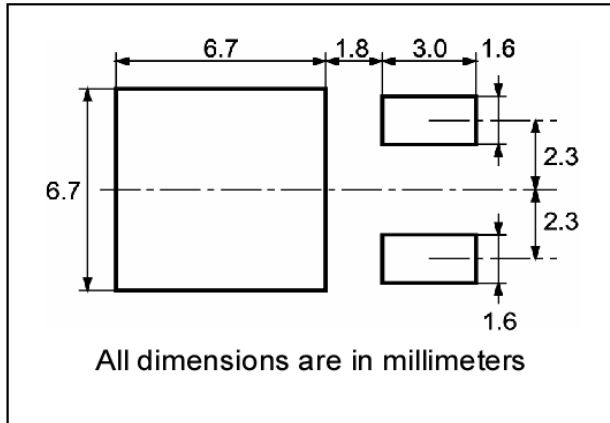

**TUBE SHIPMENT (no suffix)\***

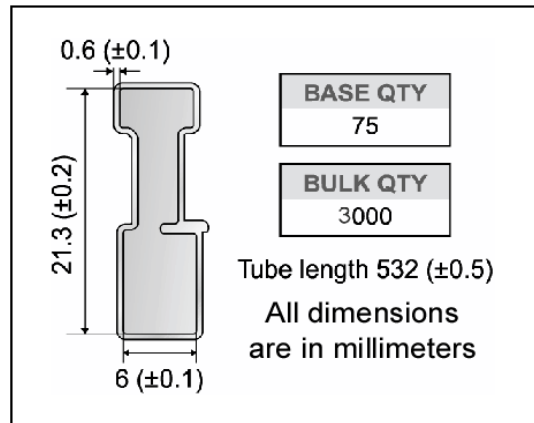

**TAPE AND REEL SHIPMENT (suffix "T4")\***

40 mm min. Access hole at slot location

Full radius

Tape slot in core for tape start 2.5mm min. width

G measured at hub

**REEL MECHANICAL DATA**

DIM.	mm		inch	
	MIN.	MAX.	MIN.	MAX.
A		330		12.992
B	1.5		0.059	
C	12.8	13.2	0.504	0.520
D	20.2		0.795	
G	16.4	18.4	0.645	0.724
N	50		1.968	
T		22.4		0.881

BASE QTY	BULK QTY
1000	1000

**TAPE MECHANICAL DATA**

DIM.	mm		inch	
	MIN.	MAX.	MIN.	MAX.
A0	6.8	7	0.267	0.275
B0	10.4	10.6	0.409	0.417
B1		12.1		0.476
D	1.5	1.6	0.059	0.063
D1	1.5		0.059	
E	1.65	1.85	0.065	0.073
F	7.4	7.6	0.291	0.299
K0	2.55	2.75	0.100	0.108
P0	3.9	4.1	0.153	0.161
P1	7.9	8.1	0.311	0.319
P2	1.9	2.1	0.075	0.082
R	40		1.574	
W	15.7	16.3	0.618	0.641

10 pitches cumulative tolerance on tape +/- 0.2 mm

Center line of cavity

Bending radius R min.

FEED DIRECTION

For machine ref. only including draft and radii concentric around B0

Information furnished is believed to be accurate and reliable. However, STMicroelectronics assumes no responsibility for the consequences of use of such information nor for any infringement of patents or other rights of third parties which may result from its use. No license is granted by implication or otherwise under any patent or patent rights of STMicroelectronics. Specifications mentioned in this publication are subject to change without notice. This publication supersedes and replaces all information previously supplied. STMicroelectronics products are not authorized for use as critical components in life support devices or systems without express written approval of STMicroelectronics.

The ST logo is registered trademark of STMicroelectronics  
All other names are the property of their respective owners.

© 2004 STMicroelectronics - All Rights Reserved

**STMicroelectronics GROUP OF COMPANIES**

Australia - Belgium - Brazil - Canada - China - Czech Republic - Finland - France - Germany - Hong Kong - India - Israel - Italy - Japan -  
Malaysia - Malta - Morocco - Singapore - Spain - Sweden - Switzerland - United Kingdom - United States.

[www.st.com](http://www.st.com)