

## Fully Integrated GPS/Galileo/Glonass/QZSS Receiver with embedded RF and in-package Flash

Data brief – preliminary data

### Features

- STMicroelectronics® 3<sup>rd</sup> generation positioning receiver with 32 Tracking channels and 2 fast acquisition channels compatible with GPS, Galileo and Glonass systems
- Embedded RF Front-End with separate GPS/Galileo/QZSS and Glonass IF outputs
- Embedded low noise amplifier
- -162 dBm indoor sensitivity (tracking mode)
- Fast TTFF < 1 s in Hot start and 35 s in Cold Start
- High performance ARM946 MCU (up to 208 MHz)
- 256 Kbyte embedded SRAM
- In-Package SQI Flash Memory (16 Mbits)
- Real Time Clock (RTC) circuit
- 32-bit Watch-dog timer
- 3 UARTs
- 1 I<sup>2</sup>C master/slave interface
- 1 Synchronous Serial Port (SSP, Motorola-SPI supported) or 1 External SQI Flash interface
- USB2.0 dual-role full speed (12 MHz) with integrated physical layer transceiver
- 2 Controller Area Network (CAN)
- 2 channels ADC (10 bits)
- 3 Embedded 1.8 V voltage regulators
- I/O level selectable 1.8 V or 3.3 V
- Operating Condition:
  - V<sub>DD12</sub>: 1.2 V ±10%
  - V<sub>DD18/RF18</sub>: 1.8 V ±5%
  - V<sub>LPVR</sub> 1.62 V to 3.6 V
  - V<sub>ddIO</sub>: 1.8 V ±5%; 3.3 V ±10%

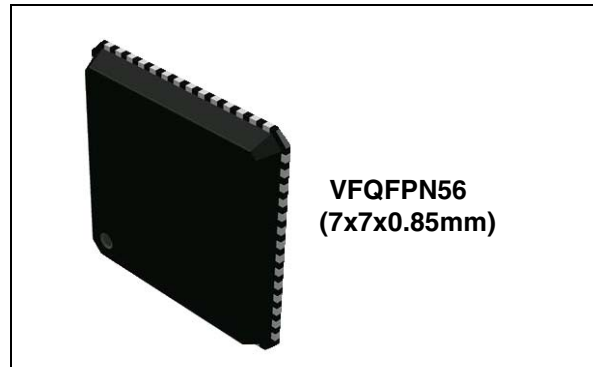

- Package:
  - VFQFPN56 (7 x 7 x 0.85 mm) 0.4 mm pitch
- Ambient temperature range: -40/+85°C

### Description

STA8088FG is a single die standalone positioning receiver IC working on multiple constellations (GPS/Galileo/Glonass/QZSS).

The minimum BOM make STA8088FG the ideal solution for low-cost and small footprint products such handheld computers, cameras, data loggers, and sports accessories.

The device is offered with a complete GNSS firmware which performs all GNSS operations including tracking, acquisition, navigation and data output with no need of external memories

# Contents

- 1 Overview ..... 5**
- 2 Pin description ..... 6**
  - 2.1 Block diagram ..... 6
  - 2.2 VFQFPN56 pin configuration ..... 7
  - 2.3 Power supply pins ..... 8
  - 2.4 Main function pins ..... 9
  - 2.5 Test/emulated dedicated pins ..... 10
  - 2.6 RF front-end pins ..... 10
  - 2.7 Port 0 pins ..... 10
  - 2.8 Port 1 pins ..... 11
- 3 Package and packing information ..... 13**
  - 3.1 ECOPACK® packages ..... 13
  - 3.2 VFQFPN56 7 x 7 x 0.85 mm package information ..... 13
- 4 Ordering information ..... 15**
- 5 Revision history ..... 16**

## List of tables

Table 1.	Power supply pins . . . . .	8
Table 2.	Main function pins . . . . .	9
Table 3.	Test/emulated dedicated pins . . . . .	10
Table 4.	RF front-end pins . . . . .	10
Table 5.	Port 0 pins . . . . .	11
Table 6.	Port 1 pins . . . . .	11
Table 7.	VFQFPN56 package dimensions . . . . .	13
Table 8.	Document revision history . . . . .	16

## List of figures

Figure 1.	STA8088FG system block diagram . . . . .	6
Figure 2.	VFQFPN56 connection diagram - with CAN (bottom view) . . . . .	7
Figure 3.	VFQFPN56 connection diagram - no CAN (bottom view). . . . .	8
Figure 4.	VFQFPN56 7 x 7 x 0.85 mm package dimension. . . . .	14
Figure 5.	Ordering information scheme . . . . .	15

# 1 Overview

STA8088FG is a highly integrated System-On-Chip device designed for positioning systems applications.

The low power consumption and minimum BOM make STA8088FG the ideal solution for low-cost and battery-operated portable products such as handheld, computers, cameras, data loggers and sports accessories, as well as automotive application.

It combines a high performance ARM946 microprocessor with embedded enhanced peripherals and I/O capabilities with ST next generation triple-constellation positioning engine. The RF front-end and base band processor are able to support GPS/Galileo and Glonass navigation systems. The device is offered with a complete firmware which performs all positioning operations including tracking, acquisition, navigation and data output with no need of external memories.

It also provides clock generation via PLL, backup logic with real time clock and it supports USB2.0 standard at full speed, (12 Mbps) with on-chip PHY.

STA8088FG is software compatible with the ARM processor family. The device is power supplied with 1.8V and uses three on-chip voltage regulators to internally supply the RF front-end, core logic and the backup logic. In order to reduce the power consumption the chip can be directly powered with 1.2 V bypassing the embedded voltage regulators which will be put in power down mode.

I/O lines are compatible with 1.8 V and 3.3 V.

The chip, using STMicroelectronics CMOSRF Technology, is housed in a VFQFPN-56 (7 x 7 x 0.85 mm) package with stacked 16 Mbit Flash memory.

## 2 Pin description

### 2.1 Block diagram

Figure 1. STA8088FG system block diagram

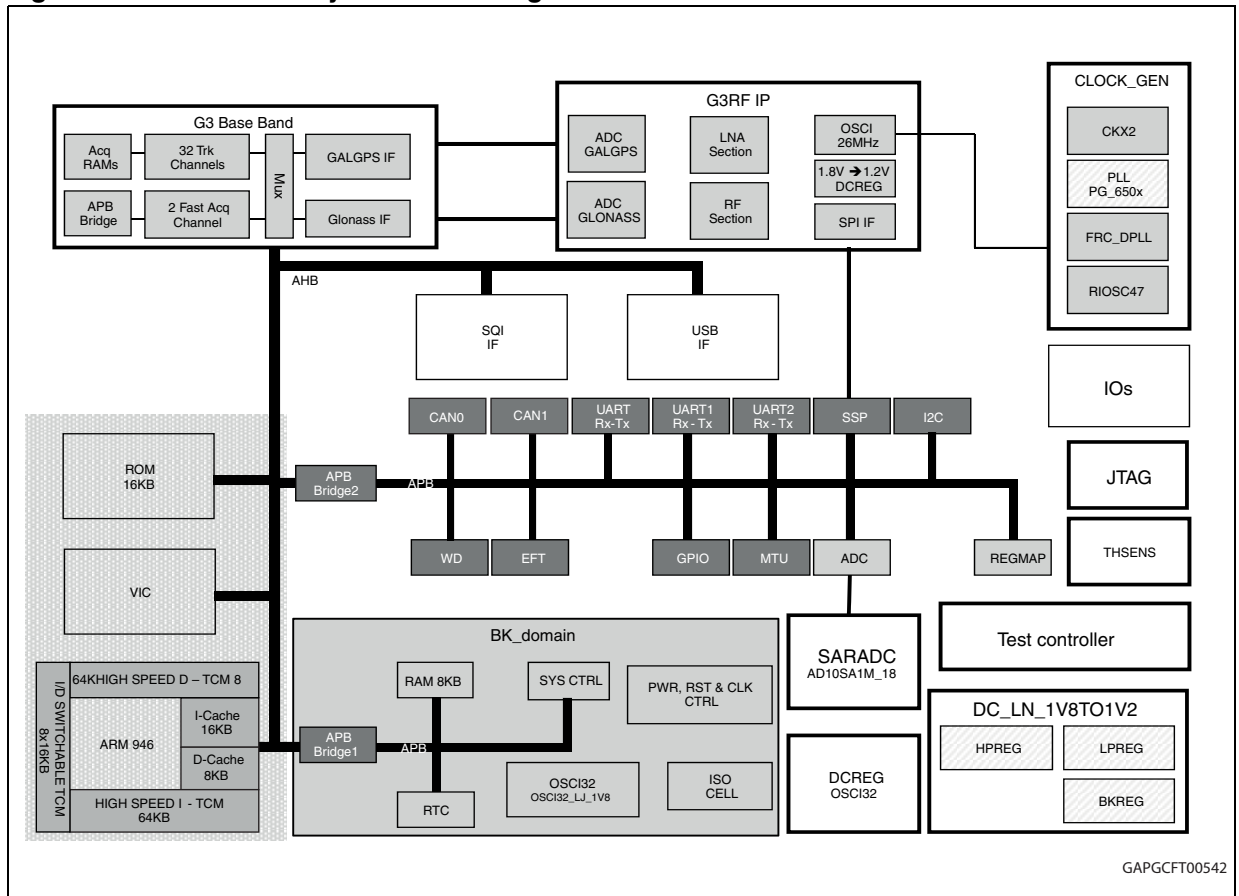

## 2.2 VFQFPN56 pin configuration

Figure 2. VFQFPN56 connection diagram - with CAN (bottom view)

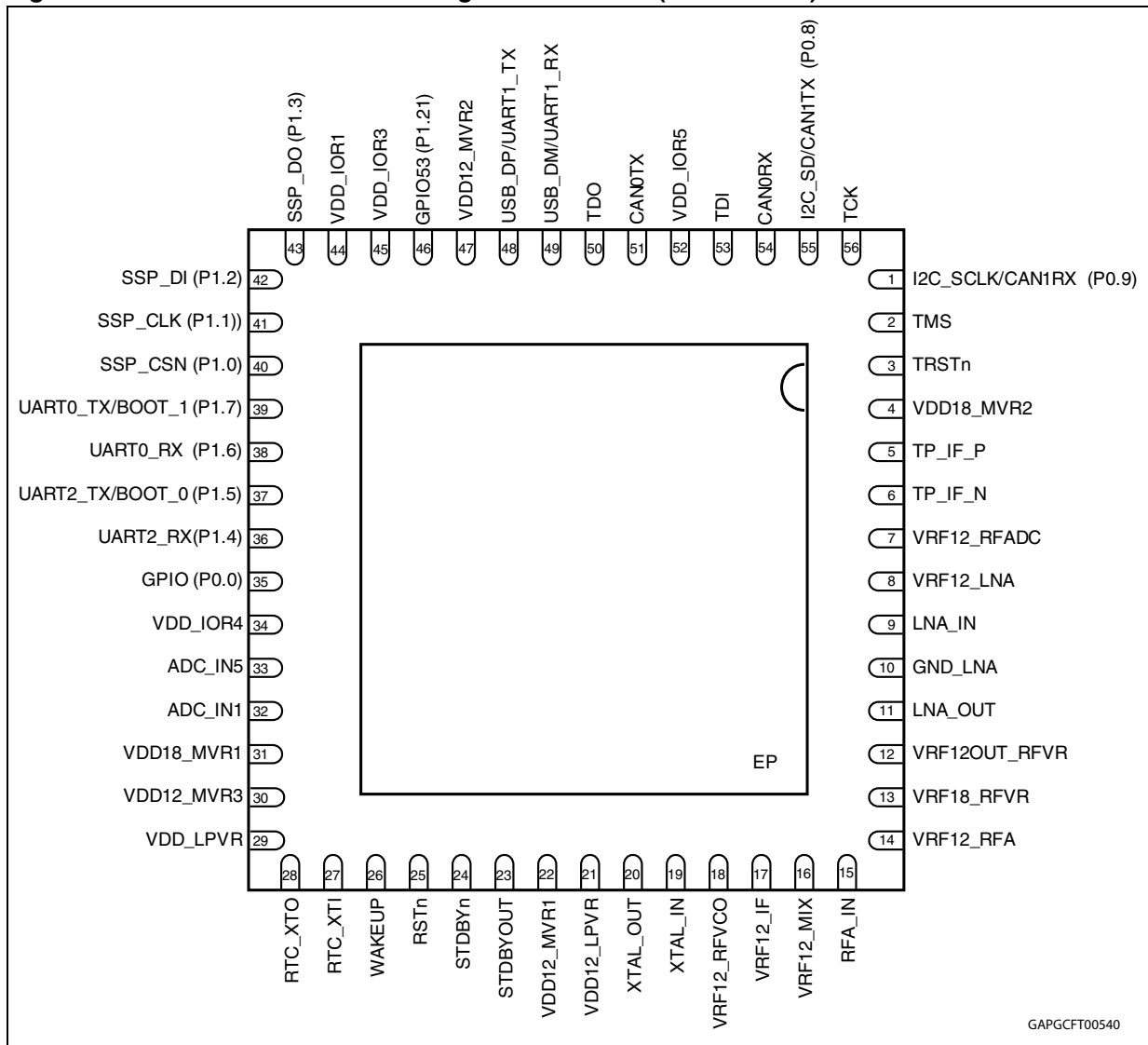
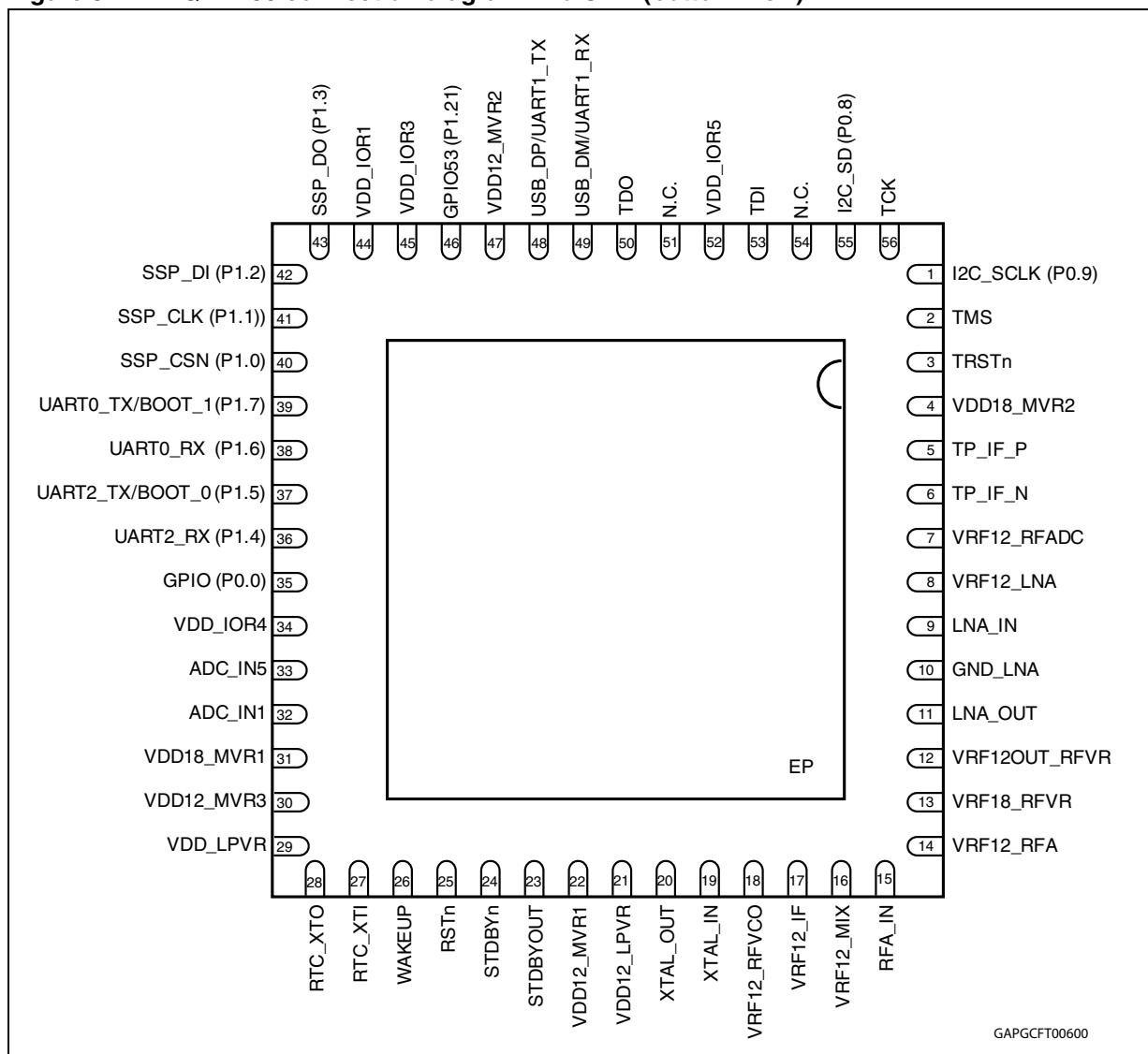

Figure 3. VFQFPN56 connection diagram - no CAN (bottom view)



### 2.3 Power supply pins

Table 1. Power supply pins

Symbol	I/O	Functions	VFQFN56
VDD18_MVR[1,2]	Pwr	Digital supply voltage for main voltage regulator (1.8 V)	31,4
VDD12_MVR[1,2,3]	Pwr	Digital supply voltage for core circuitry (1.2 V). When using the MVR, this pin shall not be driven by an external voltage supply, but a capacitance shall be connected between these pins and GND to guarantee on-chip voltage stability.	22,47,30
VDD_LPVR	Pwr	Digital supply voltage for low power voltage regulator (1.62 - 3.6 V)	29



Table 1. Power supply pins (continued)

Symbol	I/O	Functions	VFQFN56
VDD12_LPVR	Pwr	Digital supply voltage for backup logic (1.2 V). When using the LPVR, this pin shall not be driven by an external voltage supply, but a capacitance shall be connected between these pins and GND to guarantee on-chip voltage stability.	21
VDD_IOR1	Pwr	Digital supply voltage for I/O ring 1 (1.8 or 3.3 V)	44
VDD_IOR3	Pwr	Digital supply voltage for I/O ring 3 (1.8 V)	45
VDD_IOR4	Pwr	Digital supply voltage for I/O ring 4 (1.8 V)	34
VDD_IOR5	Pwr	Digital supply voltage for I/O ring 5 (3.3 V)	52
VRF18_RFVR	Pwr	Analog supply voltage for RF voltage regulator (1.8 V)	13
VRF12OUT_RFVR	Pwr	RF voltage regulator 1.2 V output	12
VRF12_LNA	Pwr	Analog supply voltage for LNA (1.2 V)	8
VRF12_RFA	Pwr	Analog supply voltage for RFA (1.2 V)	14
VRF12_MIX	Pwr	Analog supply voltage for Mixer (1.2 V)	16
VRF12_IF	Pwr	Analog supply voltage for IF (1.2 V)	17
VRF12_RFVCO	Pwr	Analog supply voltage for VCO (1.2 V)	18
VRF12_RFADC	Pwr	Analog supply voltage for RF ADC (1.2 V)	7
GND_LNA	GND	Analog supply ground for LNA	10
GND	GND	Analog and digital supply ground	EP

## 2.4 Main function pins

Table 2. Main function pins

Symbol	I/O voltage	I/O	Functions	VFQFN56
STDBYn	1.2V	I	When low, the chip is forced in Standby Mode - All pins in high impedance except the ones powered by Backup supply	24
STDBYOUT	1.2V	O	When low, indicates the chip is in Standby Mode.	23
RSTn	1.2V	I	Reset Input with Schmitt-Trigger characteristics and noise filter.	25
WAKEUP	1.2V	I	WAKEUP from STANDBY mode	26
RTC_XTI	1.5V (Max)	I	Input of the 32 KHz oscillator amplifier circuit and input of the internal real time clock circuit.	27
RTC_XTO	1.5V (Max)	O	Output of the oscillator amplifier circuit.	28
ADC_IN[1,5]	1.4V – 0 Typ Range	I	ADC Analog input [1,5]	32,33
USB_DP/UART1_TX	VDD_IOR5	USB/O	USB D+ signal / UART 1 Tx data	48
USB_DM/UART1_RX	VDD_IOR5	USB/I	USB D- signal / UART 1 Rx data	49

Table 2. Main function pins (continued)

Symbol	I/O voltage	I/O	Functions	VFQFPN56
CAN0TX <sup>(1)</sup>	VDD_IOR5	O	CAN0 - transmit data output	51
CAN0RX <sup>(1)</sup>	VDD_IOR5	I	CAN0 - receive data input	54

1. Only for STA8088FGB (see [Figure 5: Ordering information scheme](#)).

## 2.5 Test/emulated dedicated pins

Table 3. Test/emulated dedicated pins

Symbol	I/O voltage	I/O	Functions	VFQFPN56
TDO	VDD_IOR5	O	JTAG test data out	50
TDI	VDD_IOR5	I	JTAG test data in	53
TCK	VDD_IOR5	I	JTAG test clock	56
TMS	VDD_IOR5	I	JTAG test mode select	2
TRSTn	VDD_IOR5	I	JTAG test circuit reset	3
TP_IF_P	VRF12_IF	O	Diff. test point for IF – positive	5
TP_IF_N	VRF12_IF	O	Diff. test point for IF – negative	6

## 2.6 RF front-end pins

Table 4. RF front-end pins

Symbol	I/O voltage	I/O	Functions	VFQFPN56
LNA_IN	VRF12_LNA	I	Low noise amplifier input	9
LNA_OUT	VRF12_LNA	O	Low noise amplifier output	11
RFA_IN	VRF12_RFA	I	RF amplifier input	15
XTAL_In	VRF12_RFDig	I	Input side of crystal oscillator or TCXO input	19
XTAL_Out	VRF12_RFDig	O	Output side of crystal oscillator	20

## 2.7 Port 0 pins

Port 0 consists of a 32-bit bidirectional I/O port (only 3-bit are used in STA8088FG).

It can be either used as general purpose Input or Output port, or configured according to the associated alternate functions.

**Table 5. Port 0 pins**

Symbol	I/O voltage	I/O	Mode	Functions	VFQFPN56
P0.0	VDD_IOR1	IO	Default	GPIO.0: General Purpose IO	35
		I	A	PPS_IN: Pulse Per Second Input	
		O	B	PPS_OUT: Pulse Per Second Output	
		O	C	SSP_CSN: SSP Chip Select Active Low	
P0.8	VDD_IOR5	O	Default	CAN1TX <sup>(1)</sup> : CAN1 Transmit Data Output	55
		IO	A	GPIO.8: General Purpose IO	
		IO	B	I2C_SD: I2C Serial Data	
P0.9	VDD_IOR5	I	Default	CAN1RX <sup>(1)</sup> : CAN 1 Receive Data Input	1
		IO	A	GPIO.9: General Purpose IO	
		O	B	I2C_SCLK: I2C Clock	

1. Only for STA8088FGB (see [Figure 5: Ordering information scheme](#)).

## 2.8 Port 1 pins

Port 1 consists of a 32-bit bidirectional I/O port (only 9-bit are used in STA8088FG).

It can be either used as general purpose Input or Output port, or configured according to the associated alternate functions.

**Table 6. Port 1 pins**

Symbol	I/O Voltage	I/O	Mode	Functions	VFQFPN56
P1.0	VDD_IOR1	O	Default	SSP_CSN/IOPWRSEL_R1: SSP chip select active low / I/O Ring 1 power selection	40
		I/O	A	GPIO32: general purpose I/O	
		I/O	B	SIGNGGPS: GGPS 3-bit coding output (sign)	
		O	C	SQI_CEN: SQI Flash chip enable	
P1.1	VDD_IOR1	I/O	Default	SSP_CLK: SSP clock	41
		I/O	A	GPIO33: general purpose I/O	
		I/O	B	CLOCK_GGPS: GGPS clock out	
		O	C	SQI_CLK: SQI Flash clock	
P1.2	VDD_IOR1	I	Default	SSP_DI: SSP serial data input	42
		I/O	A	GPIO34: general purpose I/O	
		I/O	B	SIGNGNS: GNS 3-bit coding output (sign)	
		IO	C	SQI_SIO0/SI: SQI Flash data I/O 0 / serial I	

Table 6. Port 1 pins (continued)

Symbol	I/O Voltage	I/O	Mode	Functions	VFQFPN56
P1.3	VDD_IOR1	O	Default	SSP_DO: SSP serial data output	43
		I/O	A	GPIO35: general purpose I/O	
		I/O	B	CLOCK_GNS: GNS clock out	
		IO	C	SQI_SIO1/SO: SQI Flash data I/O 1 / serial O	
P1.4	VDD_IOR1	I	Default	UART2_RX: UART 2 Rx data	36
		I/O	A	GPIO36: general purpose I/O	
P1.5	VDD_IOR1	I/O	Default	UART2_TX / BOOT_0: UART 2 Tx data / ARM Boot 0	37
		I/O	A	GPIO37: general purpose I/O	
P1.6	VDD_IOR1	I	Default	UART0_RX: UART 0 Rx data	38
		I/O	A	GPIO38: general purpose I/O	
		I/O	C	SQI_SIO2: SQI Flash data I/O 2	
P1.7	VDD_IOR1	I/O	Default	UART0_TX / BOOT_1: UART 0 Tx data / ARM Boot 1	39
		I/O	A	GPIO39: general purpose I/O	
		I/O	C	SQI_SIO3: SQI Flash data I/O 3	
P1.21	VDD_IOR3	I/O	A	GPIO53: general purpose I/O	46

### 3 Package and packing information

#### 3.1 ECOPACK<sup>®</sup> packages

In order to meet environmental requirements, ST offers these devices in different grades of ECOPACK<sup>®</sup> packages, depending on their level of environmental compliance. ECOPACK<sup>®</sup> specifications, grade definitions and product status are available at: [www.st.com](http://www.st.com).

ECOPACK<sup>®</sup> is an ST trademark.

#### 3.2 VFQFPN56 7 x 7 x 0.85 mm package information

Table 7. VFQFPN56 package dimensions

Symbol	Min.	Typ.	Max
<b>Common dimensions</b>			
A	0.80	0.85	0.90
A1	0	0.01	0.05
A2	0.60	0.65	0.70
A3	0.20 REF		
b	0.15	0.20	0.25
D	7.00 BSC		
D1	6.75 BSC		
D2	5.0	5.1	5.2
E	7.00 BSC		
E1	6.75 BSC		
E2	5.0	5.1	5.2
e	0.40 BSC		
θ	0°		12°
L	0.30	0.40	0.50
N	56		
Nd	14		
Ne	14		
P	0.24	0.42	0.60
Q	0.30	0.40	0.65
R	0.13	0.17	0.23

Figure 4. VFQFPN56 7 x 7 x 0.85 mm package dimension

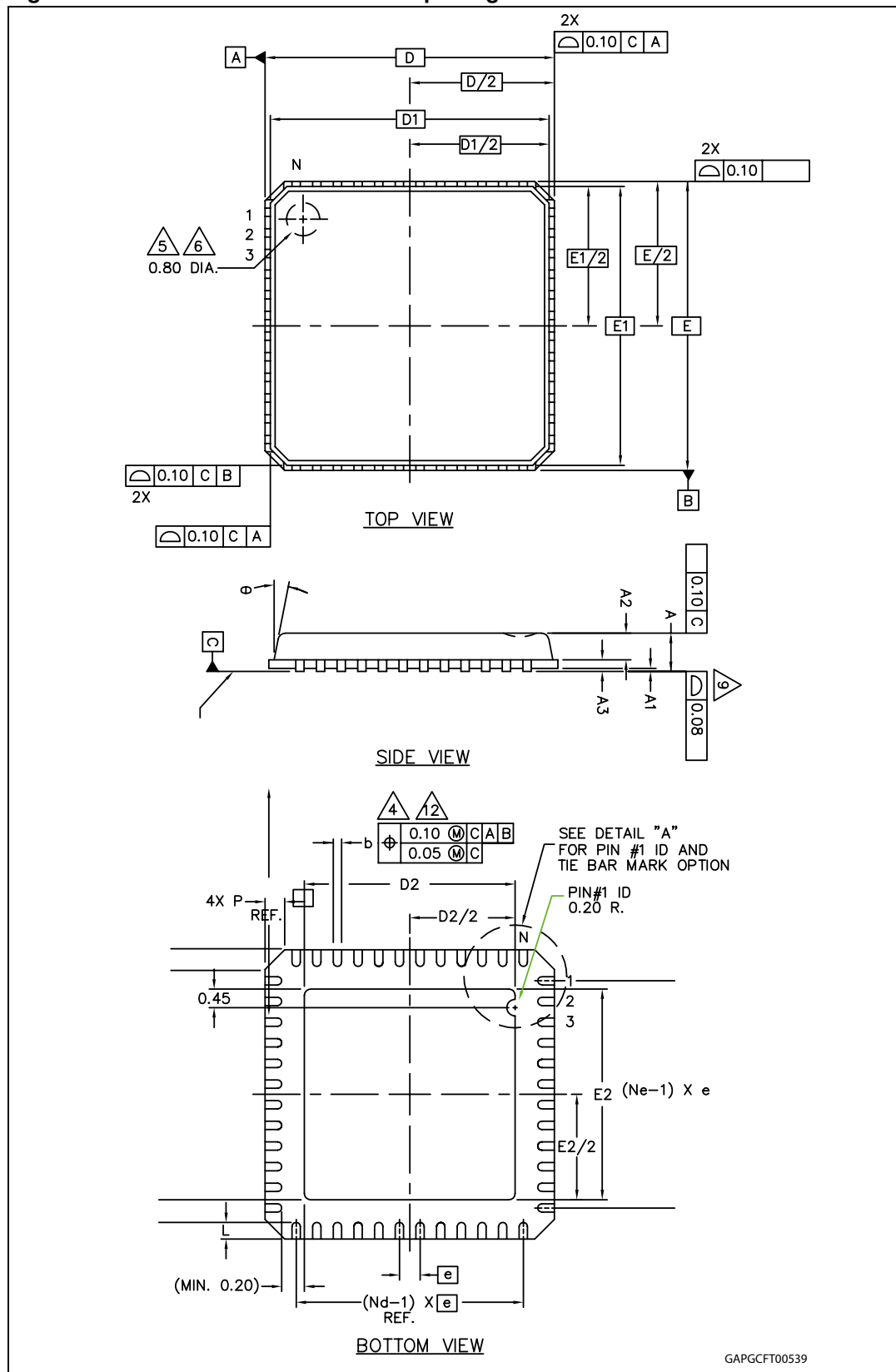

# 4 Ordering information

Figure 5. Ordering information scheme

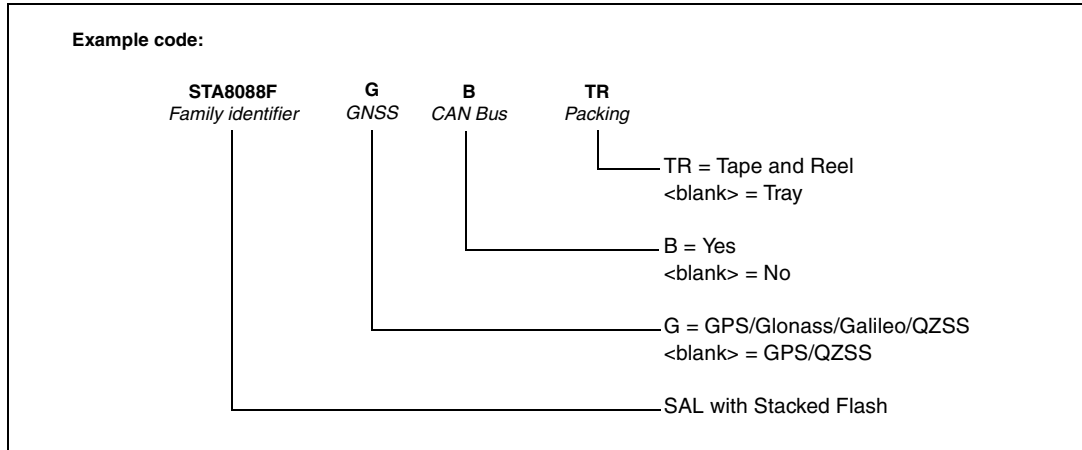

## 5 Revision history

**Table 8. Document revision history**

Date	Revision	Changes
27-Jan-2012	1	Initial release.
07-Mar-2012	2	Updated <i>Features</i> list Updated following figures: – <i>Figure 2: VFQFPN56 connection diagram - with CAN (bottom view)</i> – <i>Figure 3: VFQFPN56 connection diagram - no CAN (bottom view)</i> <i>Table 2: Main function pins:</i> – USB_DP/UART1_TX, USB_DM/UART1_RX: updated I/O



**Please Read Carefully:**

Information in this document is provided solely in connection with ST products. STMicroelectronics NV and its subsidiaries ("ST") reserve the right to make changes, corrections, modifications or improvements, to this document, and the products and services described herein at any time, without notice.

All ST products are sold pursuant to ST's terms and conditions of sale.

Purchasers are solely responsible for the choice, selection and use of the ST products and services described herein, and ST assumes no liability whatsoever relating to the choice, selection or use of the ST products and services described herein.

No license, express or implied, by estoppel or otherwise, to any intellectual property rights is granted under this document. If any part of this document refers to any third party products or services it shall not be deemed a license grant by ST for the use of such third party products or services, or any intellectual property contained therein or considered as a warranty covering the use in any manner whatsoever of such third party products or services or any intellectual property contained therein.

**UNLESS OTHERWISE SET FORTH IN ST'S TERMS AND CONDITIONS OF SALE ST DISCLAIMS ANY EXPRESS OR IMPLIED WARRANTY WITH RESPECT TO THE USE AND/OR SALE OF ST PRODUCTS INCLUDING WITHOUT LIMITATION IMPLIED WARRANTIES OF MERCHANTABILITY, FITNESS FOR A PARTICULAR PURPOSE (AND THEIR EQUIVALENTS UNDER THE LAWS OF ANY JURISDICTION), OR INFRINGEMENT OF ANY PATENT, COPYRIGHT OR OTHER INTELLECTUAL PROPERTY RIGHT.**

**UNLESS EXPRESSLY APPROVED IN WRITING BY TWO AUTHORIZED ST REPRESENTATIVES, ST PRODUCTS ARE NOT RECOMMENDED, AUTHORIZED OR WARRANTED FOR USE IN MILITARY, AIR CRAFT, SPACE, LIFE SAVING, OR LIFE SUSTAINING APPLICATIONS, NOR IN PRODUCTS OR SYSTEMS WHERE FAILURE OR MALFUNCTION MAY RESULT IN PERSONAL INJURY, DEATH, OR SEVERE PROPERTY OR ENVIRONMENTAL DAMAGE. ST PRODUCTS WHICH ARE NOT SPECIFIED AS "AUTOMOTIVE GRADE" MAY ONLY BE USED IN AUTOMOTIVE APPLICATIONS AT USER'S OWN RISK.**

Resale of ST products with provisions different from the statements and/or technical features set forth in this document shall immediately void any warranty granted by ST for the ST product or service described herein and shall not create or extend in any manner whatsoever, any liability of ST.

ST and the ST logo are trademarks or registered trademarks of ST in various countries.

Information in this document supersedes and replaces all information previously supplied.

The ST logo is a registered trademark of STMicroelectronics. All other names are the property of their respective owners.

© 2012 STMicroelectronics - All rights reserved

STMicroelectronics group of companies

Australia - Belgium - Brazil - Canada - China - Czech Republic - Finland - France - Germany - Hong Kong - India - Israel - Italy - Japan - Malaysia - Malta - Morocco - Philippines - Singapore - Spain - Sweden - Switzerland - United Kingdom - United States of America

[www.st.com](http://www.st.com)

