

44-V, 5.5-A, quad power half bridge

Features

- Minimum input output pulse width distortion
- 150 mW $R_{ds(on)}$ complementary DMOS output stage
- CMOS compatible logic inputs
- Thermal protection
- thermal warning output
- Under-voltage protection
- No power-on, power- off sequence required

Description

STA510F is a monolithic, quad, half-bridge stage in Multipower BCD technology. The device can be used as dual bridge or reconfigured, by connecting CONFIG pin to V_{DD} pin, as single bridge with double current capability, and as half bridge (binary mode) with half current capability.

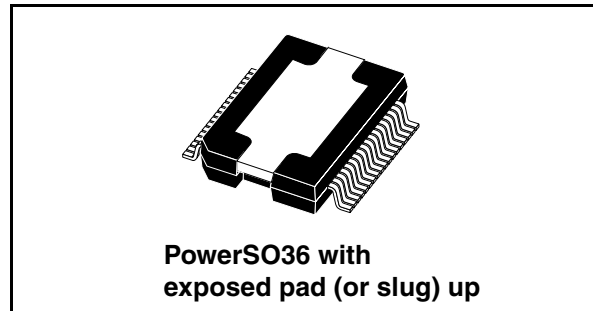

The device is particularly designed to make the output stage of a stereo all-digital high-efficiency (FFX) amplifier capable of delivering 100 W + 100 W output power into 8-Ω loads with THD = 10% and V_{CC} = 39 V. In single BTL configuration the device can deliver 200 W into a 4-Ω load with THD = 10% and V_{CC} = 39 V.

The device is fully compatible with the DDX[®] driver device.

The input pins have a threshold proportional to V_L pin voltage.

Table 1. Device summary

Order code	Operating Temp. range	Package	Packing
STA510F	0° to 70° C	PowerSO36 (slug up)	Tube

Figure 1. Typical application

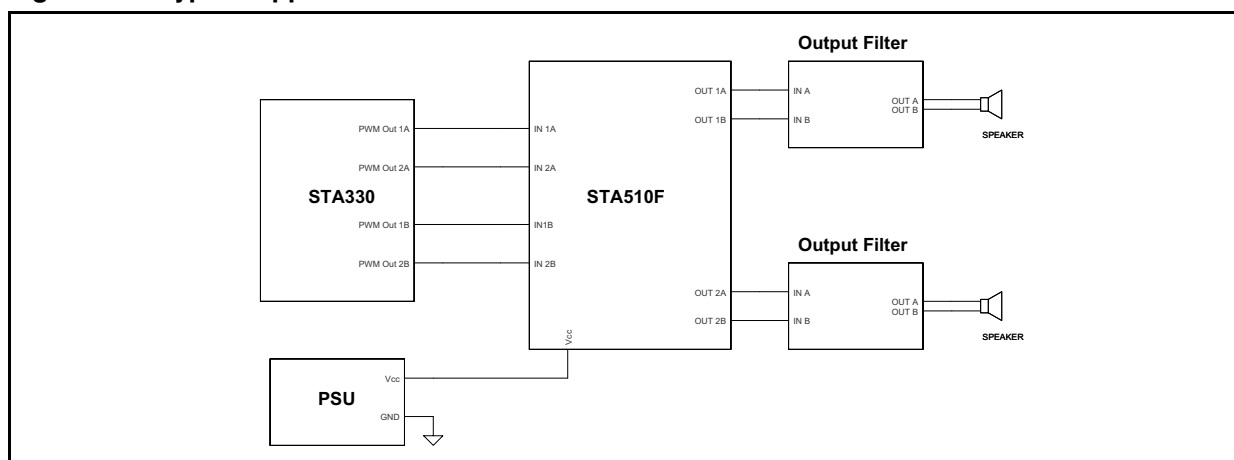

1 Pin description

Figure 2. Pin connection (top view)

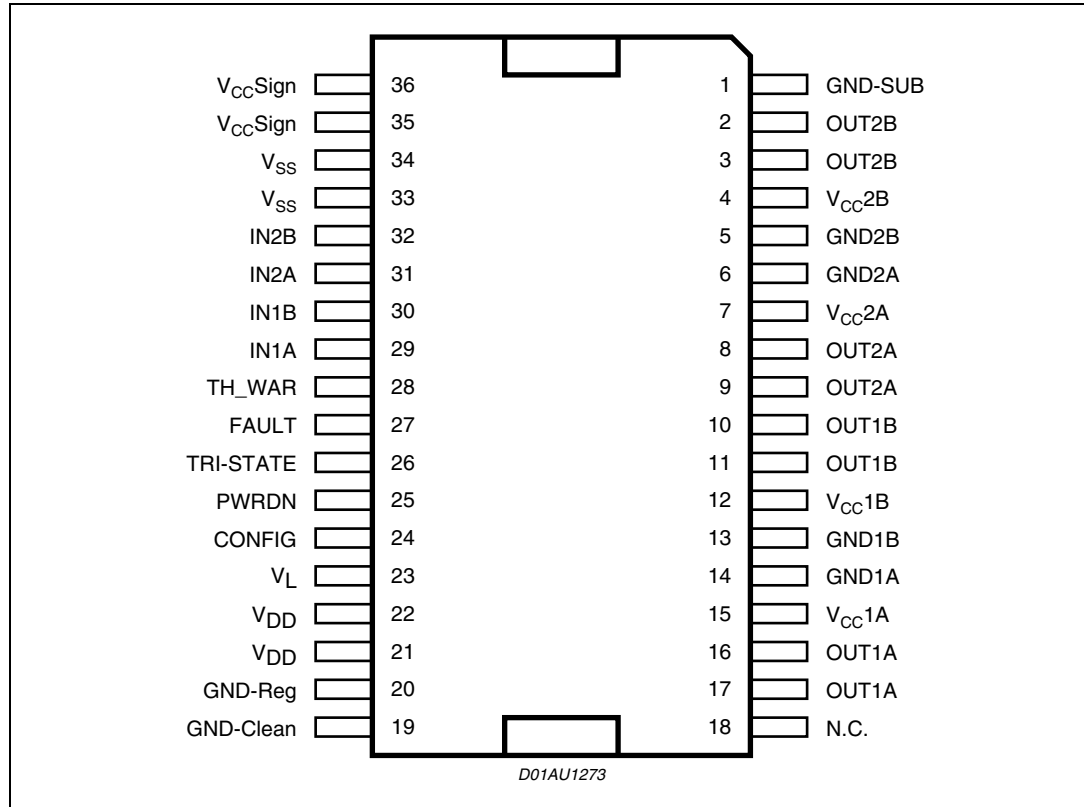

Table 2. Pin list

Pin	Name	Description
1	GND-SUB	Substrate ground
2, 3	OUT2B	Output half bridge 2B
4	V _{CC} 2B	Positive Supply
5	GND2B	Negative Supply
6	GND2A	Negative Supply
7	V _{CC} 2A	Positive Supply
8, 9	OUT2A	Output half bridge 2A
10, 11	OUT1B	Output half bridge 1B
12	V _{CC} 1B	Positive Supply
13	GND1B	Negative Supply
14	GND1A	Negative Supply
15	V _{CC} 1A	Positive Supply
16, 17	OUT1A	Output half bridge 1A

Table 2. Pin list (continued)

Pin	Name	Description
18	NC	Not connected
19	GND-clean	Logical ground
20	GND-Reg	Ground for regulator Vdd
21, 22	Vdd	5V Regulator referred to ground
23	V _L	High logical state setting voltage
24	CONFIG	Configuration
25	PWRDN	Stand-by
26	TRI-STATE	Hi-Z
27	FAULT	Fault pin advisor
28	TH-WAR	Thermal warning advisor
29	IN1A	Input of half bridge 1A
30	IN1B	Input of half bridge 1B
31	IN2A	Input of half bridge 2A
32	IN2B	Input of half bridge 2B
33, 34	Vss	5-V regulator referred to +Vcc
35, 36	VCCSIGN	Signal positive supply

Table 3.

Pin	Logical value	Device status
FAULT ⁽¹⁾	0	Fault detected (short circuit, or thermal)
	1	Normal operation
TRI-STATE	0	All power stages in Hi-Z state
	1	Normal operation
PWRDN	0	Low-power mode
	1	Normal operation
THWAR ⁽¹⁾	0	Temperature of the IC = 130° C
	1	Normal operation
CONFIG ⁽²⁾	0	Normal Operation
	1	OUT1A = OUT1B, OUT2A = OUT2B (IF IN1A = IN1B and IN2A = IN2B)

1. The pin is open collector. To have the high logic value, it needs a pull-up resistor.
2. CONFIG = 1 means connect Pin 24 (CONFIG) to Pins 21, 22 (Vdd).

2 Electrical specifications

2.1 Absolute maximum ratings

Table 4. Absolute maximum ratings

Symbol	Parameter	Value	Unit
V _{CC}	DC supply voltage (Pin 4, 7, 12, 15)	44	V
V _{max}	Maximum voltage on pins 23 to 32	5.5	V
ESD	Max ESD on pins (HBM)	±1000	V
T _{op}	Operating temperature range	0 to 70	° C
T _{stg} , T _j	Storage and junction temperature	-40 to 150	° C

2.2 Thermal data

Table 5. Thermal data

Symbol	Parameter	Min	Typ	Max	Unit
T _{j-case}	Thermal resistance junction to case (thermal pad)		1	2.5	°C/W
T _{jSD}	Thermal shut-down junction temperature		150		° C
T _{warn}	Thermal warning temperature		130		° C
t _{hSD}	Thermal shut-down hysteresis		25		° C

2.3 Electrical specifications

Unless otherwise stated, the results in [Table 6](#) below are given for the conditions: V_L = 3.3 V, V_{cc} = 37 V and T = 25° C unless otherwise specified.

Table 6. Electrical specifications

Symbol	Parameter	Condition	Min	Typ	Max	Unit
R _{dsON}	Power Pchannel/Nchannel MOSFET RdsON	I _d = 1 A		150	200	mΩ
I _{dss}	Power Pchannel/Nchannel leakage current				100	μA
g _N	Power Pchannel RdsON matching	I _d = 1 A	95			%
g _P	Power Nchannel RdsON matching	I _d = 1 A	95			%
Dt _s	Low current dead time (static)	see test circuit Figure 3		10	20	ns
Dt _d	High current dead time (dynamic)	L=22μH, C = 470nF, R _L = 8 Ω, I _d = 4.5 A, see test circuit Figure 4			50	ns

Table 6. Electrical specifications (continued)

Symbol	Parameter	Condition	Min	Typ	Max	Unit
$t_{d\ ON}$	Turn-on delay time	Resistive load			100	ns
$t_{d\ OFF}$	Turn-off delay time	Resistive load			100	ns
t_r	Rise time	Resistive load, as Figure 4			25	ns
t_f	Fall time	Resistive load, as Figure 4			25	ns
V_{CC}	Supply voltage operating voltage		10		40	V
$V_{IN-High}$	High level input voltage		$V_L/2 + 300\text{ mV}$			V
V_{IN-Low}	Low level input voltage				$V_L/2 - 300\text{ mV}$	V
I_{IN-H}	High level input current	Pin voltage = V_L		1		μA
I_{IN-L}	Low level input current	Pin voltage = 0.3V		1		μA
$I_{PWRDN-H}$	High level PWRDN pin input current	$V_L = 3.3\text{V}$		35		μA
V_{Low}	Low logical state voltage (pins PWRDN, TRISTATE) (see Table 7)	$V_L = 3.3\text{V}$			0.8	V
V_{High}	High logical state voltage (pins PWRDN, TRISTATE) (see Table 7)	$V_L = 3.3\text{V}$	1.7			V
$I_{VCC-PWRDN}$	Supply current from Vcc in power down	PWRDN = 0			3	mA
I_{FAULT}	Output current pins FAULT -TH-WARN when FAULT CONDITIONS	$V_{pin} = 3.3\text{V}$		1		mA
$I_{VCC-hiz}$	Supply current from Vcc in tri-state	Pin TRI-STATE = 0		22		mA
I_{VCC}	Supply current from Vcc in operation (both channel switching)	Input pulse width duty cycle = 50%, switching frequency = 384 kHz, no LC filters;		70		mA
I_{OUT-SH}	Overcurrent protection threshold I_{sc} (short circuit current limit) (note 2)		5.5	7	9	A
V_{UV}	Undervoltage protection threshold			7		V
t_{pw_min}	Output minimum pulse width	No Load	25		40	ns

Table 7. V_{Low} , V_{High} threshold variation with V_L

V_L	$V_{Low\ max}$	$V_{High\ min}$	Unit
2.7	0.7	1.5	V
3.3	0.8	1.7	V
5	0.85	1.85	V

Table 8. Logic truth table

TRI-STATE	INxA	INxB	Q1	Q2	Q3	Q4	Output mode
0	x	x	OFF	OFF	OFF	OFF	Hi-Z
1	0	0	OFF	OFF	ON	ON	DUMP
1	0	1	OFF	ON	ON	OFF	NEGATIVE
1	1	0	ON	OFF	OFF	ON	POSITIVE
1	1	1	ON	ON	OFF	OFF	Not used

Figure 3. Test circuit for low current dead time

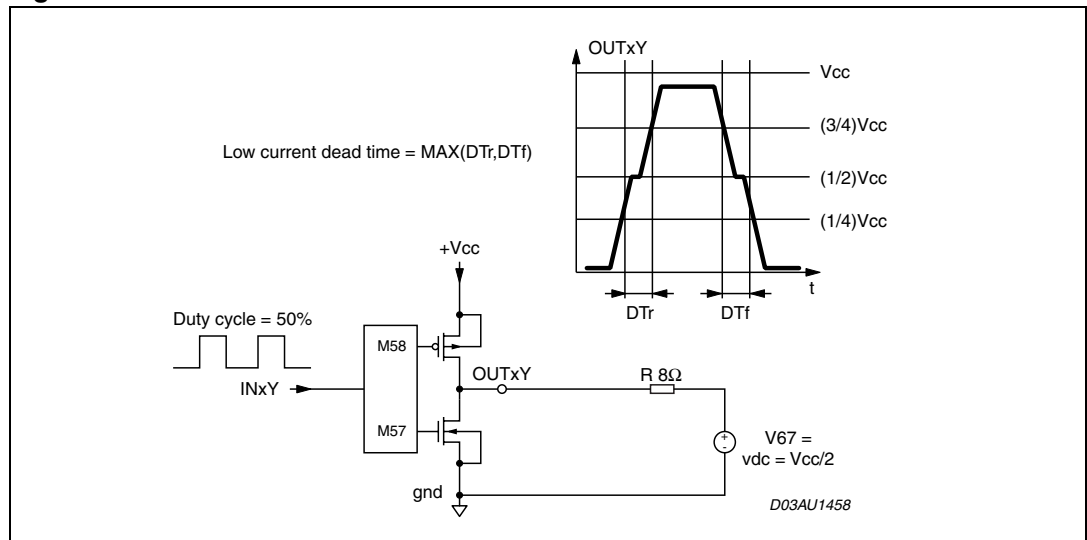

Figure 4. Test circuit for high current dead time

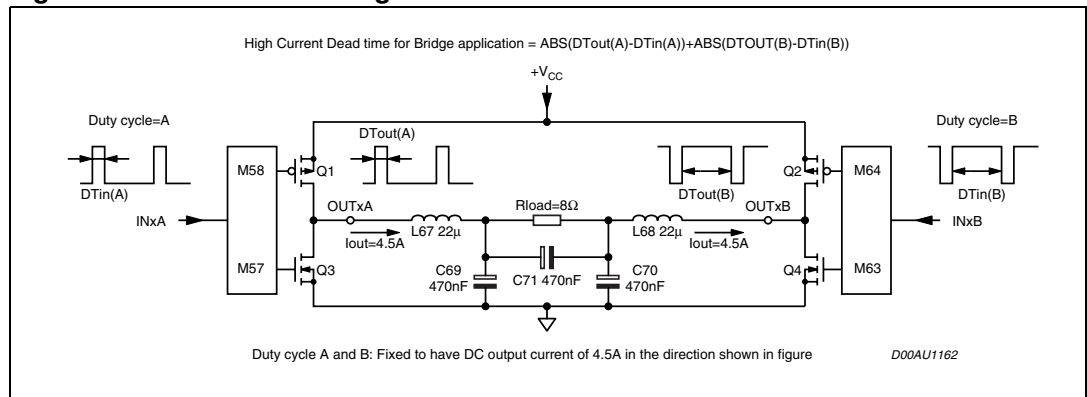

Figure 5. Typical quad half-bridge configuration giving 200 W per channel into 4 Ω speakers, 10% THD, V_{CC} = 39 V

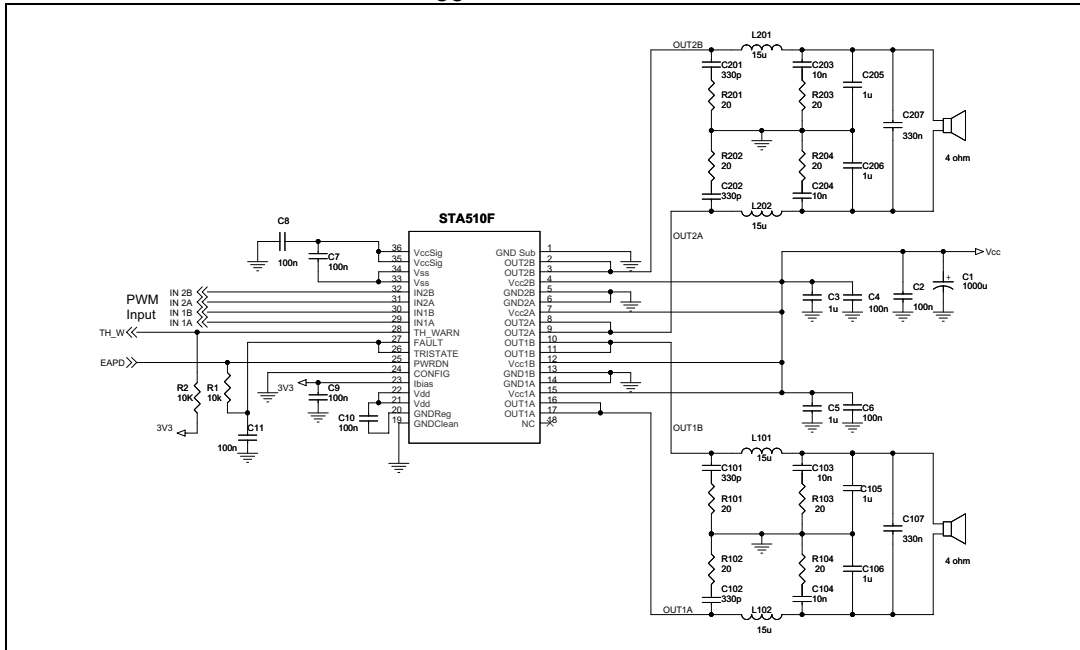
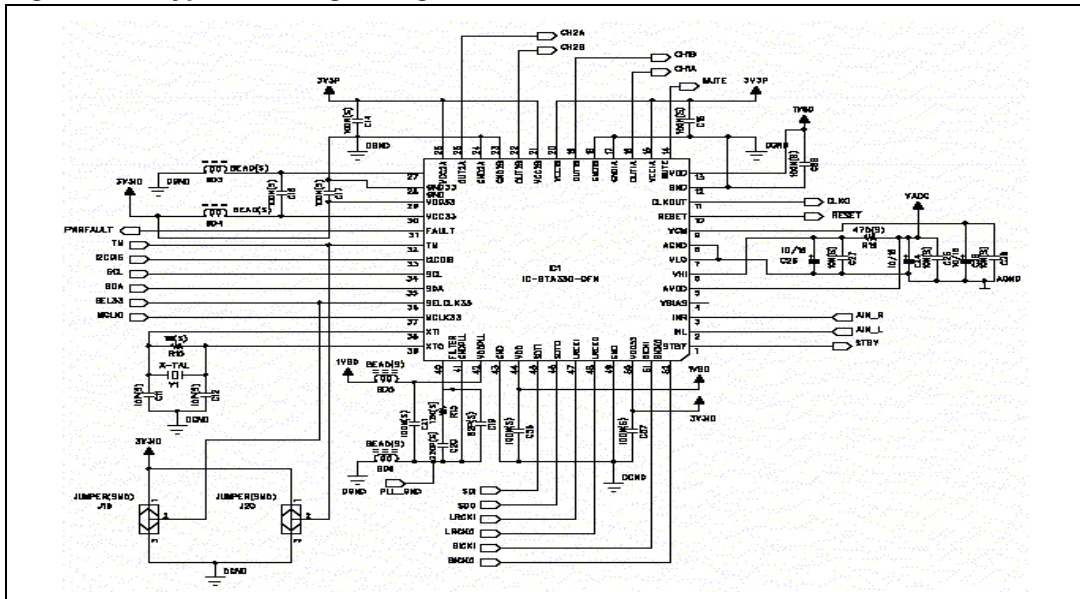

Figure 6. Typical driving configuration with STA330



3 Package information

In order to meet environmental requirements, ST offers these devices in ECOPACK[®] packages. These packages have a Lead-free second level interconnect. The category of second Level Interconnect is marked on the package and on the inner box label, in compliance with JEDEC Standard JESD97. The maximum ratings related to soldering conditions are also marked on the inner box label. ECOPACK is an ST trademark.

ECOPACK specifications are available at: <http://www.st.com>.

Figure 7. PowerSO36 package dimensions

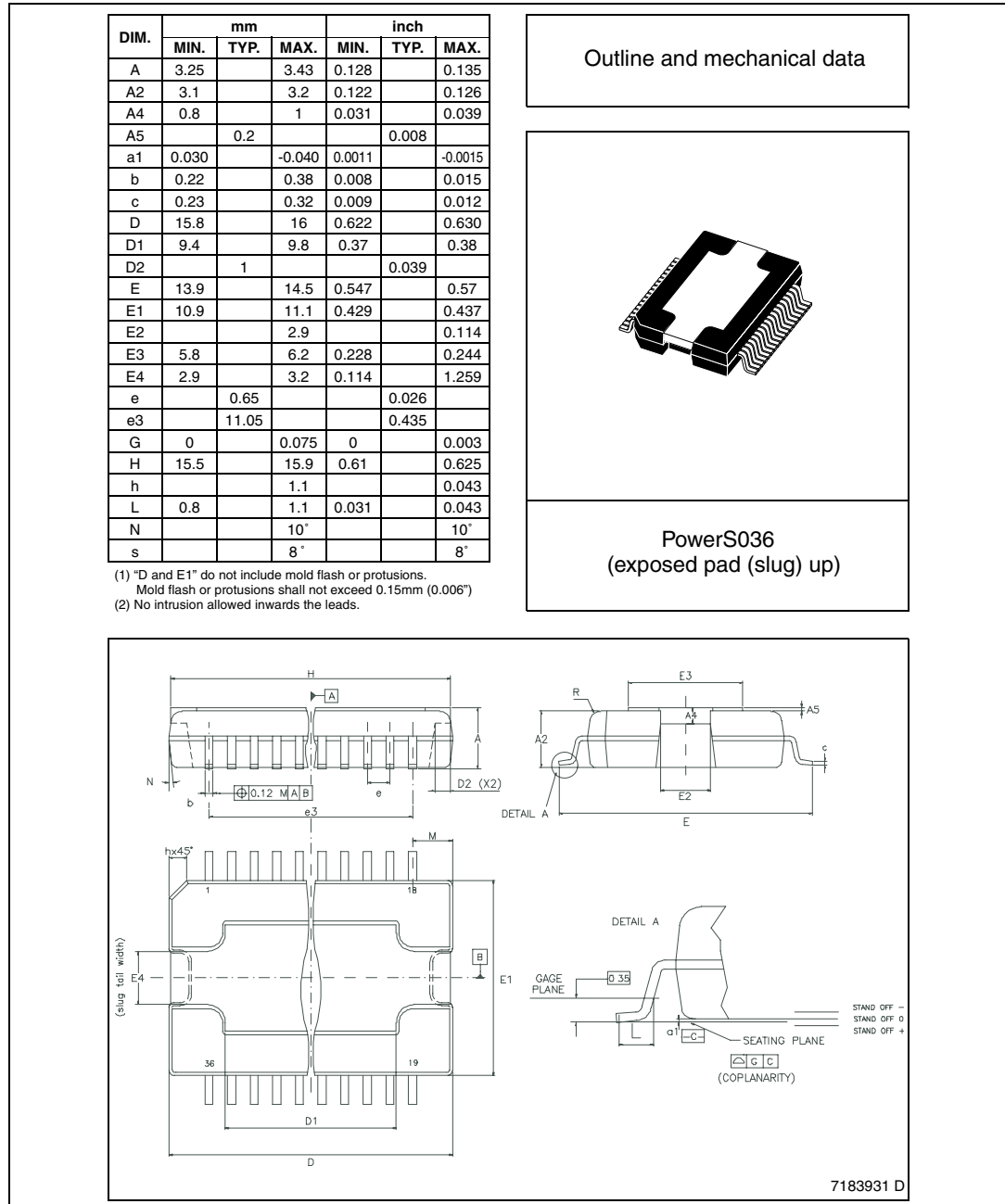

4 Trademarks and other acknowledgements

FFX is a STMicroelectronics proprietary digital modulation technology.

DDX is a registered trademark of Apogee Technology, Inc.

ECOPACK is a registered trademark of STMicroelectronics.

5 Revision history

Table 9. Document revision history

Date	Revision	Changes
13-Dec-2007	1	Initial release.

Please Read Carefully:

Information in this document is provided solely in connection with ST products. STMicroelectronics NV and its subsidiaries ("ST") reserve the right to make changes, corrections, modifications or improvements, to this document, and the products and services described herein at any time, without notice.

All ST products are sold pursuant to ST's terms and conditions of sale.

Purchasers are solely responsible for the choice, selection and use of the ST products and services described herein, and ST assumes no liability whatsoever relating to the choice, selection or use of the ST products and services described herein.

No license, express or implied, by estoppel or otherwise, to any intellectual property rights is granted under this document. If any part of this document refers to any third party products or services it shall not be deemed a license grant by ST for the use of such third party products or services, or any intellectual property contained therein or considered as a warranty covering the use in any manner whatsoever of such third party products or services or any intellectual property contained therein.

UNLESS OTHERWISE SET FORTH IN ST'S TERMS AND CONDITIONS OF SALE ST DISCLAIMS ANY EXPRESS OR IMPLIED WARRANTY WITH RESPECT TO THE USE AND/OR SALE OF ST PRODUCTS INCLUDING WITHOUT LIMITATION IMPLIED WARRANTIES OF MERCHANTABILITY, FITNESS FOR A PARTICULAR PURPOSE (AND THEIR EQUIVALENTS UNDER THE LAWS OF ANY JURISDICTION), OR INFRINGEMENT OF ANY PATENT, COPYRIGHT OR OTHER INTELLECTUAL PROPERTY RIGHT.

UNLESS EXPRESSLY APPROVED IN WRITING BY AN AUTHORIZED ST REPRESENTATIVE, ST PRODUCTS ARE NOT RECOMMENDED, AUTHORIZED OR WARRANTED FOR USE IN MILITARY, AIR CRAFT, SPACE, LIFE SAVING, OR LIFE SUSTAINING APPLICATIONS, NOR IN PRODUCTS OR SYSTEMS WHERE FAILURE OR MALFUNCTION MAY RESULT IN PERSONAL INJURY, DEATH, OR SEVERE PROPERTY OR ENVIRONMENTAL DAMAGE. ST PRODUCTS WHICH ARE NOT SPECIFIED AS "AUTOMOTIVE GRADE" MAY ONLY BE USED IN AUTOMOTIVE APPLICATIONS AT USER'S OWN RISK.

Resale of ST products with provisions different from the statements and/or technical features set forth in this document shall immediately void any warranty granted by ST for the ST product or service described herein and shall not create or extend in any manner whatsoever, any liability of ST.

ST and the ST logo are trademarks or registered trademarks of ST in various countries.

Information in this document supersedes and replaces all information previously supplied.

The ST logo is a registered trademark of STMicroelectronics. All other names are the property of their respective owners.

© 2007 STMicroelectronics - All rights reserved

STMicroelectronics group of companies

Australia - Belgium - Brazil - Canada - China - Czech Republic - Finland - France - Germany - Hong Kong - India - Israel - Italy - Japan - Malaysia - Malta - Morocco - Singapore - Spain - Sweden - Switzerland - United Kingdom - United States of America

www.st.com