



ST7580

FSK, PSK multi-mode power line networking system-on-chip

Features

- Fully integrated narrow-band power line networking system-on-chip
- High-performing PHY processor with embedded turnkey firmware featuring:
 - B-FSK modulation up to 9.6 kbps
 - B-PSK, Q-PSK, 8-PSK modulations up to 28.8 kbps
 - Dual channel operation mode
 - Convolutional error correction coding
 - Signal-to-noise ratio estimation
 - B-PSK with PNA mode against impulsive noise
- Protocol engine embedding turnkey communication protocol
 - Framing service
 - Error detection
 - Sniffer functionality
- Host controller UART interface up to 57.6 kbps
- AES-128 based authentication and confidentiality services
- Fully integrated analog front end:
 - ADC and DAC
 - Digital transmission level control
 - PGA with automatic gain control
 - High sensitivity receiver
- Fully integrated single-ended power amplifier for line driving
 - Up to 1 A RMS, 14 V p-p output
 - Configurable active filtering topology
 - Very high linearity
 - Embedded temperature sensor
 - Current control feature
- 8 to 18 V power amplifier supply
- 3.3 V or 5 V digital I/O supply
- Zero crossing detection

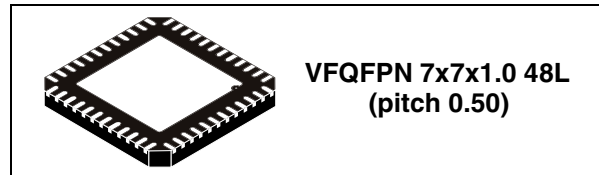

- Suitable for EN50065, FCC part 15 and ARIB compliant applications
- Communication carrier frequency programmable up to 250 kHz
- VFQFPN48 7x7x1.0 48L exposed pad package
- -40 °C to +85 °C temperature range

Applications

- Smart metering applications
- Street lighting control
- Command and control networking

Description

The ST7580 is a flexible power line networking system-on-chip combining a high performing PHY processor core and a protocol controller with a fully integrated analog front end (AFE) and line driver for a scalable future-proof, cost effective, single chip, narrow-band power line communication solution.

Table 1. Device summary

Order codes	Package	Packaging
ST7580	VFQFPN48	Tube
ST7580TR		Tape and reel

Contents

1	Device overview	3
2	Pin connection	4
	2.1 Pin description	5
3	Maximum ratings	7
	3.1 Absolute maximum ratings	7
	3.2 Thermal data	7
4	Electrical characteristics	8
5	Analog front end (AFE)	14
	5.1 Reception path	14
	5.2 Transmission path	15
	5.3 Power amplifier	15
	5.4 Current and voltage control	16
	5.5 Thermal shutdown and temperature control	17
	5.6 Zero crossing comparator	17
6	Power management	18
	6.1 Ground connections	19
7	Clock management	21
8	Functional overview	21
	8.1 References	22
9	Physical layer	23
	9.1 PSK modulations	23
	9.1.1 PSK modes	23
	9.1.2 PSK physical frame	24
	9.2 FSK modulations	24
	9.2.1 FSK options	24
	9.2.2 FSK physical frame	26

	9.2.3	FSK settings	26
	9.3	Channel and modulation selection	26
10		Data link layer	28
	10.1	Data link frame	28
	10.2	Error detection and sniffer mode	28
	10.3	Security services	28
11		Package mechanical data	29
12		Revision history	31

1 Device overview

Made using multi-power technology with state-of-the-art VLSI CMOS lithography, the ST7580 is based on dual digital core architecture (a PHY processor engine and a protocol controller core) to guarantee outstanding communication performance with a high level of flexibility for either open standards or customized implementations.

A HW 128-bit AES encryption block with customizable key management is available on chip when secure communication is requested.

The on-chip analog front end featuring analog to digital and digital to analog conversion, automatic gain control, plus the integrated power amplifier delivering up to 1 A RMS output current makes the ST7580 a unique system-on-chip for power line communication.

Line coupling network design is also simplified, leading to a very low cost BOM.

Robust and performing operations are guaranteed while keeping power consumption and signal distortion levels very low; this makes the ST7580 an ideal platform for the most stringent application requirements and regulatory standards compliance.

Figure 1. Block diagram

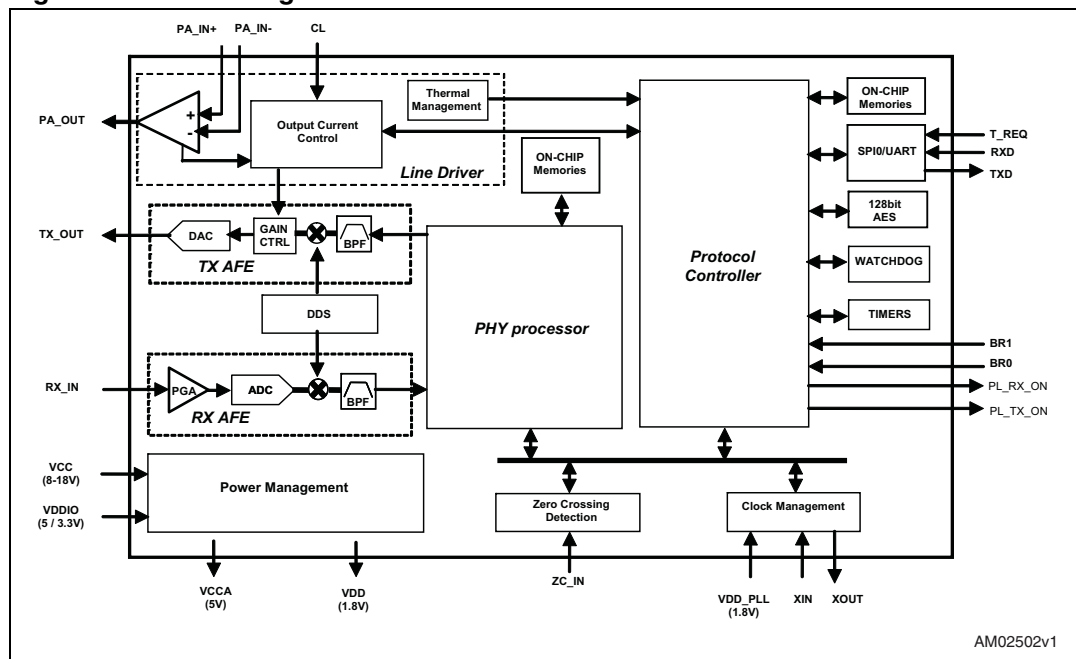

2 Pin connection

Figure 2. Pinout top view

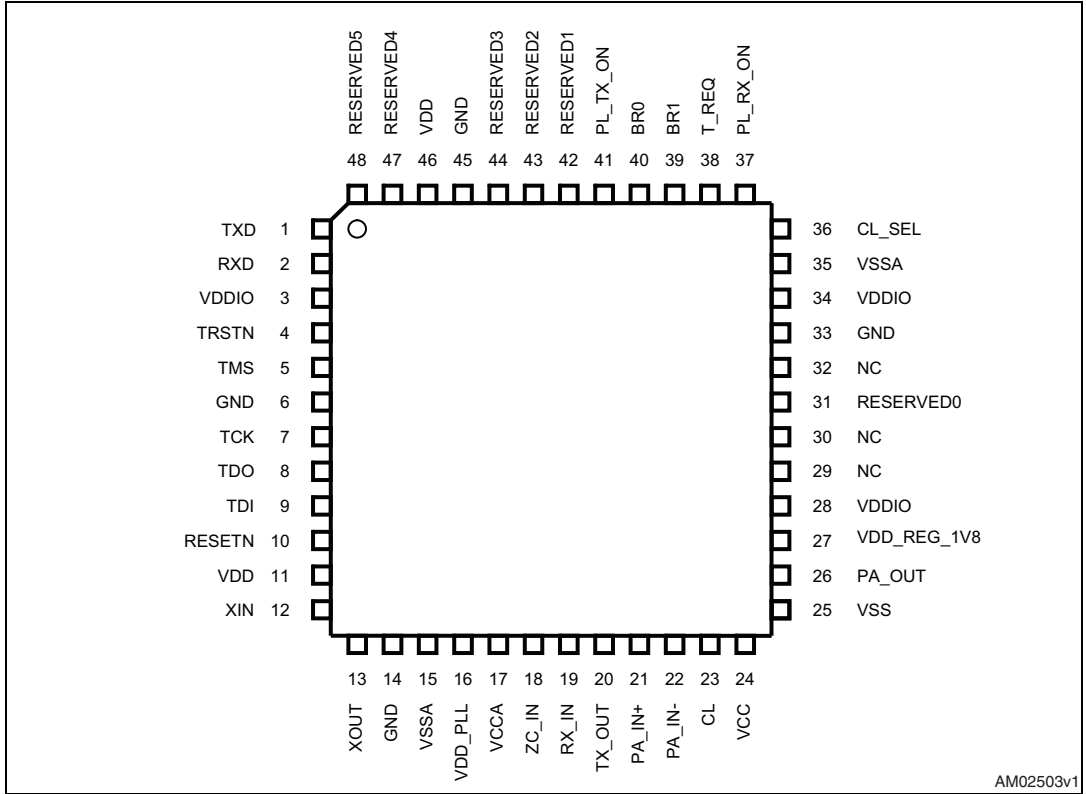

2.1 Pin description

Table 2. Pin description

Pin	Name	Type	Reset state	Internal Pull-up	Description
1	TXD	Digital output	High Z	Disabled	UART data out. External pull-up to VDDIO required
2	RXD	Digital input	High Z	Disabled	UART data in
3	VDDIO	Power	-	-	3.3 V – 5 V I/O supply
4	TRSTN	Digital input	Input	Enabled	System JTAG interface reset (active low)
5	TMS	Digital input	Input	Enabled	System JTAG interface mode select
6	GND	Power	-	-	Digital ground
7	TCK	Digital input	High Z	Disabled	System JTAG interface clock. External pull-up to VDDIO required
8	TDO	Digital output	High Z	Disabled	System JTAG interface data out
9	TDI	Digital input	Input	Enabled	System JTAG interface data in
10	RESETN	Digital input	Input	Disabled	System reset (active low)
11	VDD	Power	-	-	1.8 V digital supply
12	XIN	Analog	-	-	Crystal oscillator input / external clock input
13	XOUT	Analog	-	-	Crystal oscillator output (if external clock is supplied on XIN, XOUT must be left floating)
14	GND	Power	-	-	Digital ground
15	VSSA	Power	-	-	Analog ground
16	VDD_PLL	Power	-	-	1.8 V PLL supply voltage (connect to VDD)
17	VCCA	Power	-	-	5 V analog supply / internal regulator output. Externally accessible for filtering purposes only.
18	ZC_IN	Analog input	-	-	Zero crossing input If not used connect to VSSA
19	RX_IN	Analog input	-	-	Reception analog input
20	TX_OUT	Analog output	-	-	Transmission analog output
21	PA_IN+	Analog input	-	-	Power amplifier Non-inverting input
22	PA_IN-	Analog input	-	-	Power amplifier Inverting input
23	CL	Analog input	-	-	Current limit sense input
24	VCC	Power	-	-	Power supply
25	VSS	Power	-	-	Power ground
26	PA_OUT	Analog output	-	-	Power amplifier output

Table 2. Pin description (continued)

Pin	Name	Type	Reset state	Internal Pull-up	Description
27	VDD_REG_1V8	Power	-	-	1.8 V digital supply / internal regulator output. Externally accessible for filtering purposes only
28	VDDIO	Power	-	-	3.3 V - 5 V I/O supply
29	NC	-	-	-	Not used, leave floating
30	NC	-	-	-	Not used, leave floating
31	RESERVED0	Power	-	-	Pull-up to VDDIO.
32	NC	-	-	-	Not used, leave floating
33	GND	Power	-	-	Digital ground
34	VDDIO	Power	-	-	3.3 V – 5 V I/O supply
35	VSSA	Power	-	-	Analog ground
36	CL_SEL	Digital output	High Z	Disabled	Current limit resistor selection output
37	PL_RX_ON	Digital output	High Z	Disabled	Reception in progress output
38	T_REQ	Digital input	High Z	Disabled	UART communication control line
39	BR1	Digital input	High Z	Disabled	UART baud rate selection (sampled after each reset event) see Table 3 .
40	BR0	Digital Input	High Z	Disabled	
41	PL_TX_ON	Digital output	High Z	Disabled	Transmission in progress output
42	RESERVED1	-	-	-	Pull up to VDDIO
43	RESERVED2	-	-	-	Pull up to VDDIO
44	RESERVED3	-	-	-	Pull up to VDDIO
45	GND	Power	-	-	Digital ground
46	VDD	Power	-	-	1.8 V digital supply
47	RESERVED4	-	-	-	Connect to VDDIO
48	RESERVED5	-	-	-	Pull up to VDDIO
-	Exposed pad	-	-	-	Electrically connected to VSSA. It is recommended that the exposed pad be thermally connected to a copper ground plane for enhanced electrical and thermal performance.

Table 3. UART baud rate selection

BR0	BR1	Baud rate
0	0	9600
0	1	19200
1	0	38400
1	1	57600

3 Maximum ratings

3.1 Absolute maximum ratings

Figure 3. Absolute maximum ratings

Symbol	Parameter	Value		Unit
		Min.	Max.	
VCC	Power supply voltage	-0.3	20	V
VSSA-GND	Voltage between VSSA and GND	-0.3	0.3	V
VDDIO	I/O supply voltage	-0.3	5.5	V
VI	Digital input voltage	GND-0.3	VDDIO+0.3	V
VO	Digital output voltage	GND-0.3	VDDIO+0.3	V
V(PA_IN)	PA inputs voltage range	VSS-0.3	VCC+0.3	V
V(PA_OUT)	PA_OUT voltage range	VSS-0.3	VCC+0.3	V
V(RX_IN)	RX_IN voltage range	-(VCCA+0.3)	VCC+0.3	V
V(ZC_IN)	ZC_IN voltage range	-(VCCA+0.3)	VCCA+0.3	V
V(TX_OUT, CL)	TX_OUT, CL voltage range	VSSA-0.3	VCCA+0.3	V
V(XIN)	XIN voltage range	GND-0.3	VDDIO+0.3	V
I(PA_OUT)	Power amplifier output non-repetitive pulse current		5	A peak
I(PA_OUT)	Power amplifier output non-repetitive RMS current		1.4	A RMS
T _{amb}	Operating ambient temperature	-40	85	°C
T _{stg}	Storage temperature	-50	150	°C
V(ESD)	Maximum withstanding voltage range Test condition: CDF-AEC-Q100-002 “human body model” acceptance criteria: “normal performance”	-2	+2	kV

3.2 Thermal data

Table 4. Thermal characteristics

Symbol	Parameter	Value	Unit
R _{thJA1}	Maximum thermal resistance junction-ambient steady-state ⁽¹⁾	50	°C/W
R _{thJA2}	Maximum thermal resistance junction-ambient steady-state ⁽²⁾	42	°C/W

1. Mounted on a 2-side + vias PCB with a ground dissipating area on the bottom side.
2. Same conditions as in Note 1, with maximum transmission duration limited to 100 s.

4 Electrical characteristics

$T_A = -40$ to $+85$ °C, $T_J < 125$ °C, $V_{CC} = 18$ V unless otherwise specified.

Table 5. Electrical characteristics

Symbol	Parameter	Note	Min.	Typ.	Max.	Unit
Power supply						
VCC	Power supply voltage		8	13	18	V
I(VCC) RX	Power supply current - Rx mode	VCCA externally supplied		0.35	0.5	mA
I(VCC) TX	Power supply current - Tx mode, no load	VCCA externally supplied		22	30	mA
VCC UVLO_TL	VCC undervoltage lockout low threshold		6.1	6.5	6.95	V
VCC UVLO_TH	VCC undervoltage lockout high threshold		6.8	7.2	7.5	V
VCC UVLO_HYST	VCC undervoltage lockout hysteresis		250 ⁽¹⁾	700		mV
I(VCCA) RX	Analog supply current - Rx mode			5	6	mA
I(VCCA) TX	Analog supply current - Tx mode	V(TX_OUT) =5 V p-p, no load		8	10	mA
VDD	Digital core supply voltage	Externally supplied	-10%	1.8	+10%	V
I(VDD)	Digital core supply current			35	41	mA
I(VDD) RESET	Digital core supply current in RESET state			8		mA
VDD_PLL	PLL supply voltage			VDD		V
I(VDD_PLL)	PLL supply current			0.4	0.5	mA
VDDIO	Digital I/O supply voltage	Externally supplied	-10%	3.3 or 5	+10%	V
VDDIO UVLO_TL	VDDIO undervoltage lockout low threshold		2.2	2.4	2.6	V
VDDIO UVLO_TH	VDDIO undervoltage lockout high threshold		2.45	2.65	2.85	V
VDDIO UVLO_HYST	VDDIO undervoltage lockout hysteresis		180	240		mV

**Table 5. Electrical characteristics (continued)**

Symbol	Parameter	Note	Min.	Typ.	Max.	Unit	
Analog front end							
Power amplifier							
V(PA_OUT) BIAS	Power amplifier output bias voltage - Rx mode			VCC/2		V	
GBWP	Power amplifier gain-bandwidth product		100			MHz	
I(PA_OUT) MAX	Power amplifier maximum output current				1000	mA rms	
V(PA_OUT) TOL	Power amplifier output tolerance ⁽²⁾	VCC=18 V, V(PA_OUT) = 14 V p-p (typ.), V(PA_OUT) BIAS = VCC/2, RLOAD=50 Ω - See Figure 4	-3%		+3%		
V(PA_OUT) HD2	Power amplifier output 2 nd harmonic distortion			-70	-63	dBc	
V(PA_OUT) HD3	Power amplifier output 3 rd harmonic distortion				-66	-63	dBc
V(PA_OUT) THD	Power amplifier output total harmonic distortion				0.1	0.15	%
C(PA_IN)	Power amplifier input capacitance	PA_IN+ vs. VSS ⁽³⁾		10		pF	
		PA_IN- vs. VSS ⁽³⁾		10		pF	
PSRR	Power supply rejection ratio	50 Hz		100		dB	
		1 kHz		93		dB	
		100 kHz		70		dB	
CL_TH	Current sense high threshold on CL pin		2.25	2.35	2.4	V	
CL_RATIO	Ratio between PA_OUT and CL output current			80			
Transmitter							
V(TX_OUT) BIAS	Transmitter output bias voltage - Rx mode			VCCA/2		V	
V(TX_OUT) MAX	Transmitter output maximum voltage swing	TX_GAIN = 31, no load	4.8	4.95	VCCA	V p-p	
TX_GAIN	Transmitter output digital gain range		0		31		
TX_GAIN TOL	Transmitter output digital gain tolerance		-0.35		0.35	dB	
R(TX_OUT)	Transmitter output resistance			1		kΩ	
V(TX_OUT) HD2	Transmitter output 2 nd harmonic distortion	V(TX_OUT) = V(TX_OUT) Max. no load, T = 25 °C		-72	-67	dBc	

Table 5. Electrical characteristics (continued)

Symbol	Parameter	Note	Min.	Typ.	Max.	Unit
V(TX_OUT) HD3	Transmitter output 3 rd harmonic distortion			-70	-55	dBc
V(TX_OUT) THD	Transmitter output total harmonic distortion			0.1	0.2	%
Receiver						
V(RX_IN) MAX	Receiver input maximum voltage	VCC = 18 V			15	V p-p
V(RX_IN) BIAS	Receiver input bias voltage			VCCA/2		V
Z(RX_IN)	Receiver input Impedance			10		kΩ
V(RX_IN) MIN	Receiver input sensitivity	B-PSK coded mode, f _C = 86 kHz, BER = 10 ⁻³ , SNR ≥ 20 db ⁽³⁾		36		dBμV RMS
		FSK mode, Symbol rate = 2400, Deviation = 1, f _C = 86 kHz, BER = 10 ⁻³ , SNR ≥ 20 dB		39		dBμV RMS
PGA_MIN	PGA minimum gain			-18		dB
PGA_MAX	PGA maximum gain			30		dB
Oscillator						
V(XIN)	Oscillator input voltage swing	Clock frequency supplied externally		1.8	VDDIO	V p-p
V(XIN) TH	Oscillator input voltage threshold		0.8	0.9	1	V
f(XIN)	Crystal oscillator frequency			8		MHz
f(XIN) TOL	External quartz crystal frequency tolerance		-150		+150	ppm
ESR	External quartz crystal ESR value				100	Ω
C _L	External quartz crystal load capacitance			16	20	pF

**Table 5. Electrical characteristics (continued)**

Symbol	Parameter	Note	Min.	Typ.	Max.	Unit
f _{CLK_AFE}	Internal frequency of the analog front end			8		MHz
f _{CLK_PROTOCOL}	Internal frequency of the protocol controller core			28		MHz
f _{CLK_PHY}	Internal frequency of the PHY processor			56		MHz
Temperature sensor						
T _{TH1}	Temperature threshold 1	(3)	63	70	77	°C
T _{TH2}	Temperature threshold 2		90	100	110	°C
T _{TH3}	Temperature threshold 3		112	125	138	°C
T _{TH4}	Temperature threshold 4		153	170	187	°C
Zero crossing comparator						
V(ZC_IN) MAX	Zero crossing detection input voltage range				10	V p-p
V(ZC_IN) TL	Zero crossing detection input low threshold		-40	-30	-20	mV
V(ZC_IN) TH	Zero crossing detection input high threshold		30	40	50	mV
V(ZC_IN) HYST	Zero crossing detection input hysteresis		62	70	78	mV
ZC_IN d.c.	Zero crossing input duty cycle			50		%
Digital Section						
Digital I/O						
R _{PULL-UP}	Internal pull-up resistors	VDDIO = 3.3 V		66		kΩ
		VDDIO = 5 V		41		kΩ
V _{IH}	High logic level input voltage		0.65*VDDIO		VDDIO+0.3	V
V _{IL}	Low logic level input voltage		-0.3		0.35*VDDIO	V
V _{OH}	High logic level output voltage	I _{OH} = -4 mA	VDDIO-0.4			V
V _{OL}	Low logic level output voltage	I _{OL} = 4 mA			0.4	V

Table 5. Electrical characteristics (continued)

Symbol	Parameter	Note	Min.	Typ.	Max.	Unit
UART interface						
Baud rate			-1.5%	57600	+1.5%	BAUD
			-1.5%	38400	+1.5%	BAUD
			-1.5%	19200	+1.5%	BAUD
			-1.5%	9600	+1.5%	BAUD
Reset and power on						
t_{RESETN}	Minimum valid reset pulse duration			1		μs
t_{startup}	Startup time at power-on or after a reset event			60		ms

1. Referred to $T_{\text{amb}} = -40\text{ }^{\circ}\text{C}$.
2. This parameter does not include the tolerance of external components.
3. Guaranteed by design.

Figure 4. Power amplifier test circuit

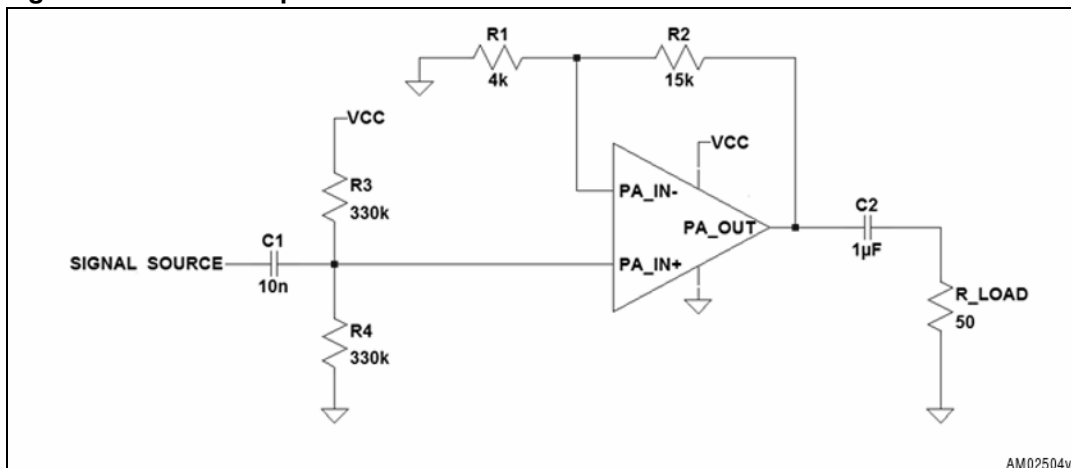

AM02504v1

Figure 5. I(VCC) vs. I(PA_OUT) curve - typical values

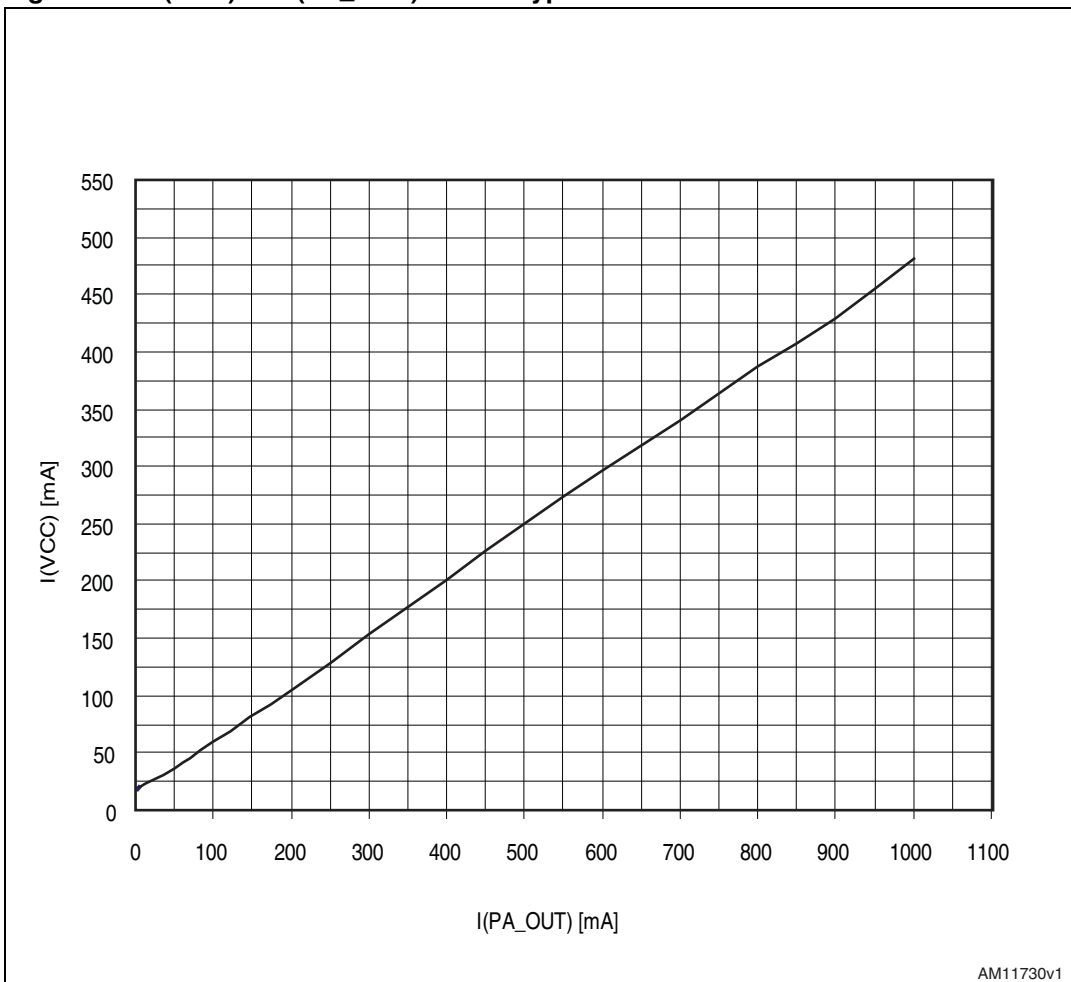

AM11730v1

5 Analog front end (AFE)

5.1 Reception path

Figure 6 shows the block diagram of the ST7580 input receiving path. The main blocks are a wide input range analog programmable gain amplifier (PGA) and the analog to digital converter (ADC).

Figure 6. Reception path block diagram

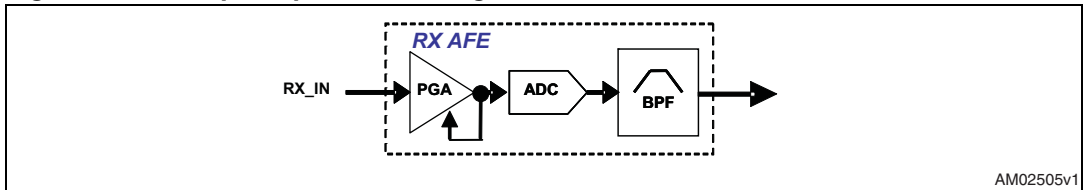

The PGA is controlled by an embedded loop algorithm, adapting the PGA gain to amplify or attenuate the input signal according to the input voltage range for the ADC.

The PGA gain ranges from -18 dB up to 30 dB, with steps of 6 dB (typ.), as described in *Table 6*.

Table 6. PGA gain table

PGA code	PGA gain (typ.) [dB]	RX_IN max. range [V p-p]
0	-18	V(RX_IN) MAX
1	-12	8
2	-6	4
3	0	2
4	6	1
5	12	0.500
6	18	0.250
7	24	0.125
8	30	0.0625

5.2 Transmission path

Figure 7 shows the transmission path block diagram. It is mainly based on a digital to analog converter (DAC), capable of generating a linear signal up to its full scale output. A gain control block before the DAC gives the possibility to scale down the output signal to match the desired transmission level.

Figure 7. Transmission path block diagram

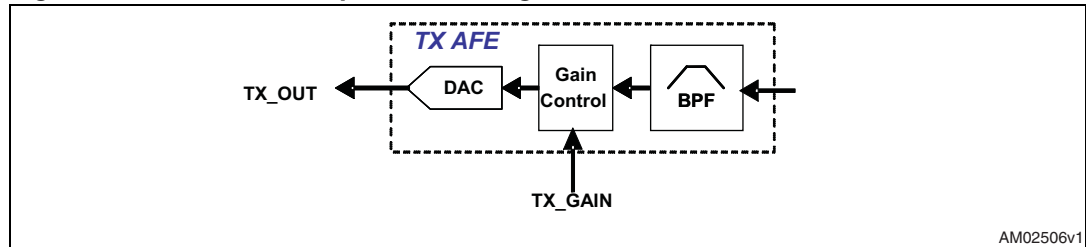

The amplitude of the transmitted signal can be set on a 32-step logarithmic scale via the TX_GAIN parameter, introducing an attenuation ranging from 0 dB (typ.), corresponding to the TX_OUT full range, down to -31 dB (typ.).

The signal level set by the TX_GAIN parameter can be calculated using the following formula:

Equation 1 output attenuation A [dB] vs. TX GAIN

$$A[\text{dB}] = (\text{TX_GAIN} - 31) \cdot \text{TX_GAIN}_{\text{TOL}}$$

5.3 Power amplifier

The integrated power amplifier is characterized by very high linearity, required to comply with the different international regulations (CENELEC, FCC, etc.) limiting the spurious conducted emissions on the mains, and a current capability of I(PA_OUT) MAX that allows the amplifier to drive even very low impedance points of the network.

All pins of the power amplifier are accessible, making it possible to build an active filter network to increase the linearity of the output signal.

5.4 Current and voltage control

The power amplifier output current sensing is performed by mirroring a fraction of the output current and making it flow through a resistor R_{CL} connected between the C_L pin and VSS . The following relationship can be established between $V(CL)$ and $I(PA_OUT)$:

Equation 2 $V(CL)$ vs. $I(PA_OUT)$

$$V(CL) = \frac{R_{CL} \cdot I(PA_OUT)}{CL_RATIO}$$

The voltage level $V(CL)$ is compared with the internal threshold CL_TH . When the $V(CL)$ exceeds the CL_TH level, the $V(TX_OUT)$ voltage is decreased by one TX_GAIN step at a time until $V(CL)$ goes below the CL_TH threshold.

The current sense circuit is depicted in [Figure 8](#).

Figure 8. PA_OUT current sense circuit

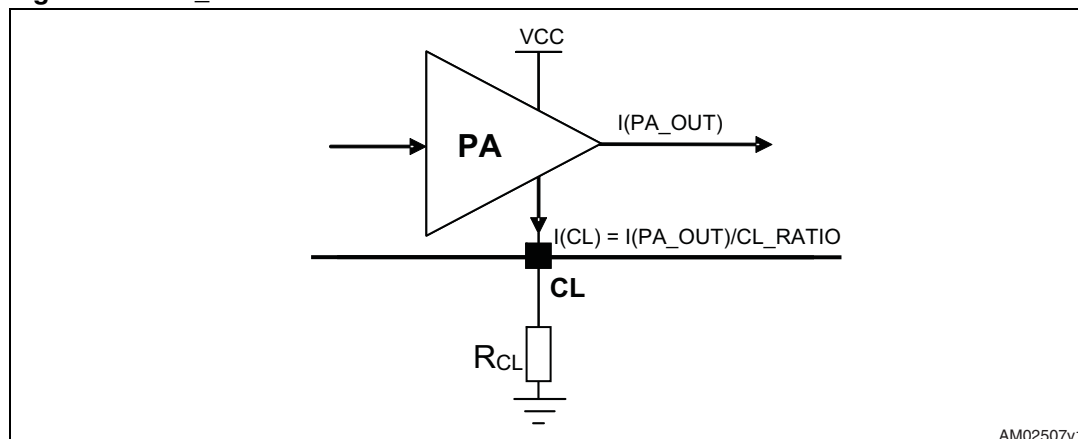

The R_{CL} value to get the desired output current limit $I(PA_OUT)_{LIM}$ can be calculated as follows:

Equation 3 R_{CL} calculation

$$R_{CL} = \frac{CL_TH}{I(PA_OUT)_{LIM} / CL_RATIO}$$

Note that $I(PA_OUT)_{LIM}$ is expressed as peak current, so the corresponding RMS current is calculated according to the transmitted signal waveform. As FSK and PSK modulations have different crest factor values, different R_{CL} values are required for the two modulations.

The R_{CL} values, to get 1 A RMS output current limit, calculated with typical values for CL_TH and CL_RATIO parameters, are indicated in [Table 7](#).

Table 7. CL resistor typical values

Parameter	Description	Value	Unit
R_{CL}	Resistor value for $I(PA_OUT)_{max.} = 1$ A RMS = 1.41 A pk (FSK mode)	133	Ω
	Resistor value for $I(PA_OUT)_{max.} = 1$ A RMS = 2 A pk (PSK mode)	94	

The CL_SEL pin can be used to switch automatically the RCL resistor value according to the used modulation. If FSK modulation is selected, CL_SEL is forced to GND, while if PSK modulation is selected, CL_SEL is in high impedance state.

5.5 Thermal shutdown and temperature control

The ST7580 performs an automatic shutdown of the power amplifier circuitry when the internal temperature exceeds T_{TH4} . After a thermal shutdown event, the temperature must go below T_{TH3} before the ST7580 power amplifier comes back into operation.

Moreover, a digital thermometer is embedded to identify the internal temperature in four zones, as indicated in [Table 8](#).

Table 8. Temperature zones

Temperature zone	Temperature value
1	$T < T_{TH1}$
2	$T_{TH1} < T < T_{TH2}$
3	$T_{TH2} < T < T_{TH3}$
4	$T > T_{TH3}$

5.6 Zero crossing comparator

The ST7580 embeds an analog comparator with hysteresis, used for optional zero crossing detection and synchronization. It requires a bipolar (ac) analog input signal, synchronous to the mains voltage.

6 Power management

Figure 9 shows the power supply structure for the ST7580. The ST7580 operates from two external supply voltages:

- VCC (8 to 18 V) for the power amplifier and the analog section
- VDDIO (3.3 or 5 V) for interface lines and digital blocks.

Two internal linear regulators provide the remaining required voltages:

- 5 V analog front end supply: generated from the VCC voltage and connected to the VCCA pin
- 1.8 V digital core supply: generated from the VDDIO voltage and connected to VDD_REG_1V8 (direct regulator output) and VDD pins.

The VDD_PLL pin, supplying the internal clock PLL, must be externally connected to VDD through a ferrite bead for noise filtering purposes.

All supply voltages must be properly filtered to their respective ground, using external capacitors close to each supply pin, in accordance with the supply scheme depicted in *Figure 9*.

Note that the internal regulators connected to VDD_REG_1V8 and to VCCA are not designed to supply external circuitry; their outputs are externally accessible for filtering purposes only.

External connections between all VDD pins are not required.

Figure 9. Power supply internal scheme and external connections

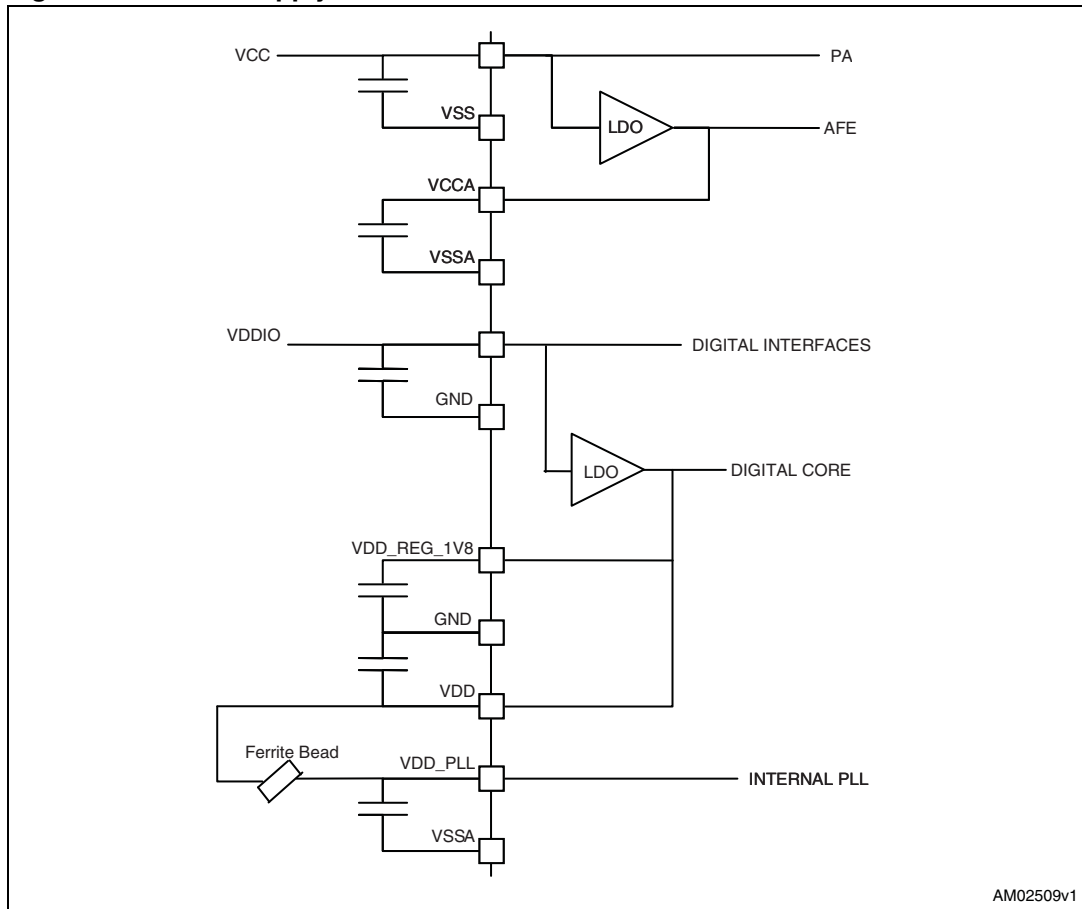

6.1 Ground connections

The ST7580 presents analog and digital ground connections. In particular, VSS is the power ground, VSSA is the analog ground, while GND pins refer to digital ground.

It is recommended to provide external connections between the ground pins as follows:

- GND pins 6, 14, 33, and 45 are connected together;
- VSSA pins 15 and 35 are connected to the exposed pad;
- VSS is also connected to the exposed pad;
- Connection between VSSA and GND is provided through a ferrite bead.

Figure 10. ST7580 ground pins and recommended external connections

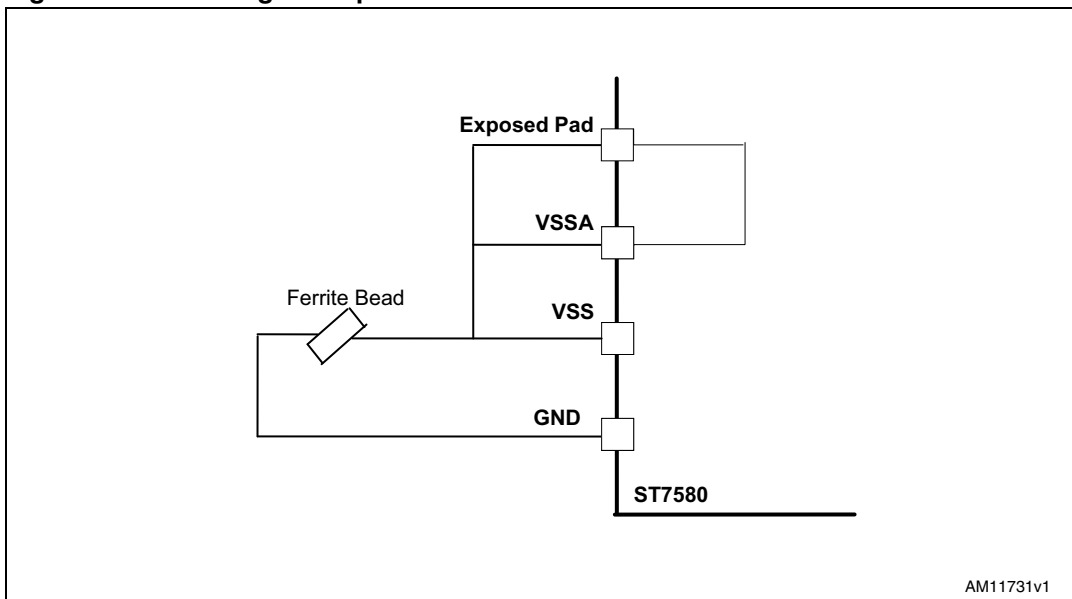

7 Clock management

The main clock source is an 8 MHz crystal connected to the internal oscillator through the XIN and XOUT pins. Both XIN and XOUT pins have a 32 pF integrated capacitor, in order to drive a crystal having a load capacitance of 16 pF with no additional components.

Alternatively, an 8 MHz external clock can be directly supplied to the XIN pin, leaving XOUT floating.

A PLL internally connected to the output of the oscillator generates the $f_{\text{CLK_PHY}}$, required by the PHY processor block engine. $f_{\text{CLK_PHY}}$ is then divided by two to obtain $f_{\text{CLK_PROTOCOL}}$, required by the protocol controller.

8 Functional overview

The ST7580 provides a complete physical layer (PHY) to the external host and some data link layer (DL) services for power line communication. It is mainly developed for smart metering applications in CENELEC A band, but suitable also for other command and control applications and remote load management in CENELEC B and D band.

A UART host interface is available for communication with an external host, exporting all the functions and services required to configure and control the device and its protocol stack.

The embedded PHY layer, hosted in the PHY processor, implements two different modulation schemes: a B-FSK modulation up to 9.6 kbps and a multi-mode PSK modulation with channel quality estimation, dual channel receiving mode, and convolutional coding, delivering a throughput up to 28.8 kbps.

The embedded DL layer hosted in the protocol controller offers framing and error correction services.

Figure 11. Functional overview

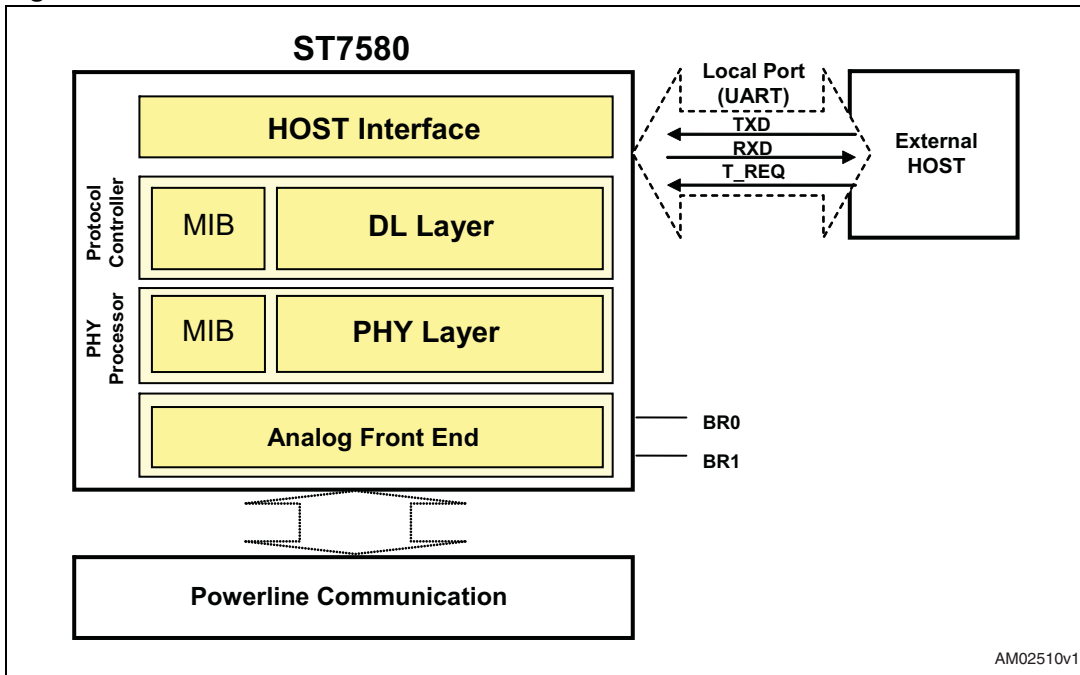

8.1 References

Additional information regarding the host interface, including a detailed description of all services and commands can be found in the following document:

- User manual UM0932

9 Physical layer

The physical layer implemented in the ST7580 provides the following services:

- Bit modulation and demodulation according to PSK and FSK schemes
- Carrier selection up to 250 kHz
- Bit, byte, and frame synchronization with training sequence and physical header
- Signal to noise ratio (SNR) estimation.

9.1 PSK modulations

The ST7580 supports several PSK (phase shift keying) modulations with a symbol rate of 9600 baud. As all PSK modulations share the same physical frame, the receiver is able to recognize the PSK modulation kind used by the transmitter without further settings.

9.1.1 PSK modes

The ST7580 supports several PSK modes:

- Uncoded modes: B-PSK, Q-PSK, 8-PSK
- Coded modes: B-PSK coded, Q-PSK coded
- B-PSK coded with peak noise avoidance (PNA) algorithm.

PSK coded modes transmit, on the power line, two coded bits for each information bit (code rate $\frac{1}{2}$), halving the bit rate of the communication, but increasing the communication robustness through error correction.

B-PSK coded with the peak noise avoidance algorithm allows an even more robust communication and it is recommended to reject impulsive noise synchronous with the mains period. PNA modulation requires the transmitter to be synchronized to the mains period: the ZC_IN pin must be connected to a zero crossing detection circuit.

[Table 9](#) summarizes all the available PSK modulations and their bit rate.

Table 9. PSK modes description

Modulation	Symbol rate [baud]	Information bits per symbol	Bit rate [bps]
B-PSK	9600	1	9600
Q-PSK	9600	2	19200
8-PSK	9600	3	28800
B-PSK coded	9600	$\frac{1}{2}$	4800
Q-PSK coded	9600	1	9600
B-PSK coded PNA	9600	$\frac{1}{4}$	2400

9.1.2 PSK physical frame

Figure 12 shows the physical frame for PSK modulations.

Figure 12. PSK physical frame structure (length in bytes)

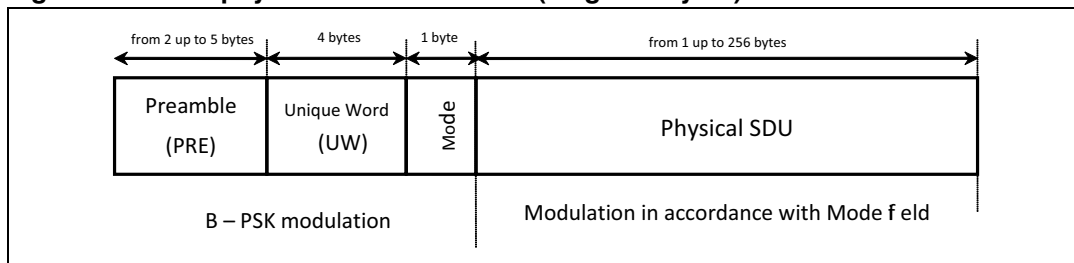

The meaning of each field is as follows:

- **Preamble:** a sequence of alternating 1 and 0 symbols (AAh bytes) required by the receiver PLL to achieve bit synchronization. Its length is programmable from 2 to 5 bytes.
- **Unique word:** a predefined sequence used to mark the start of a physical frame. The physical layer also provides SNR estimation on the received unique word.
- **Mode:** indicates the PSK mode used for the physical SDU. Thanks to this byte, the receiver can automatically detect the PSK mode to be used to properly receive the physical SDU.
- **Physical SDU (service data unit):** payload of the physical layer. Its length is specified in its first byte, which is always present.

Preamble, unique word, and mode fields are always transmitted using the B-PSK modulation. The physical layer SDU field can be sent according to any PSK modulation (B-PSK, Q-PSK, 8-PSK, B-PSK coded, Q-PSK coded, B-PSK coded PNA) expressed in the mode field.

9.2 FSK modulations

9.2.1 FSK options

The ST7580 supports several FSK (frequency shift keying) modulations with a symbol rate from 1200 to 9600 baud. Table 10 summarizes all the available FSK modulations and their bit rate.

Table 10. FSK modes description

Modulation	Symbol rate [baud]	Information bits per symbol	Bit rate [bps]
FSK @1200	1200	1	1200
FSK @2400	2400	1	2400
FSK @4800	4800	1	4800
FSK @9600	9600	1	9600

The frequency deviation (Δf) is the difference between the carrier frequency and the FSK tone.

Figure 13. Frequency deviation

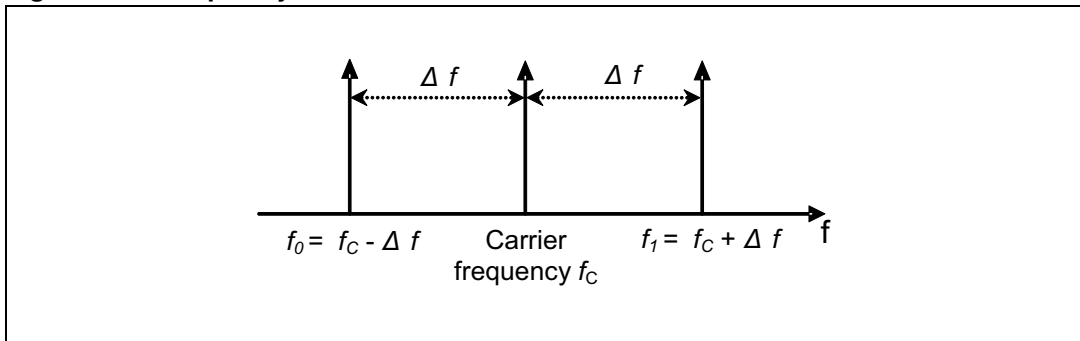

The following equation shows the frequency deviation formula for ST7580 FSK modulation:

Equation 4 Frequency deviation formula

$$\Delta f = \frac{\text{symbol_rate}}{2} * \text{deviation_factor}[\text{Hz}]$$

The deviation factor is a configurable parameter: admitted values are 1 or 0.5. [Table 11](#) summarizes the frequency deviation for all symbol rate and deviation factors.

Table 11. Frequency deviation possible values

Symbol rate [baud]	Deviation factor	
	1	0.5
1200	0.6 kHz	0.3 kHz
2400	1.2 kHz	0.6 kHz
4800	2.4 kHz	1.2 kHz
9600	4.8 kHz	2.4 kHz

9.2.2 FSK physical frame

Figure 14 shows the physical frame for FSK modulations.

Figure 14. FSK physical frame structure (length in bytes)

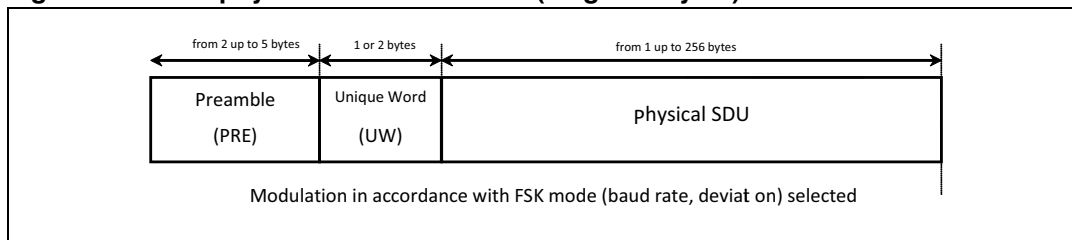

The meaning of each field is as follows:

- Preamble: a sequence of alternating 1 and 0 symbols (0xAA bytes) required by the receiver PLL to achieve bit synchronization. Its length is programmable from 2 to 5 bytes.
- Unique word: a programmable sequence used to mark the start of a physical frame. Its length and values are programmable.
- Physical SDU (service data unit): payload of the physical layer. Its length is specified in its first byte, which is always present.

9.2.3 FSK settings

In the FSK physical frame there is no automatic modulation recognition. In order to communicate using FSK modulation, the transmitter and the receiver must use the same settings in terms of baud rate, deviation and unique word. ST7580 uses a single set of FSK settings at a time, both for transmitting and receiving.

9.3 Channel and modulation selection

The ST7580 supports a range of carrier frequencies for modulation, offering a dual channel configuration for both transmission and reception. The two frequency channels f_1 , f_2 have to be set with the following constraints:

- Minimum frequency carrier value: 9 kHz
- Maximum frequency carrier for transmission: 250 kHz
- Maximum central frequency $(f_1 + f_2) / 2$: 249.999 kHz
- Maximum frequency difference $(f_1 - f_2)$: 38.461 kHz.

The transmission is always performed on one channel at a time, modulating the output signal around either the high channel or the low channel. Any modulation type can be used.

The reception can be configured in single channel mode or in dual channel mode.

- In single channel mode the receiver listens to the high channel (the carrier with a higher frequency value) only, while it neglects any communication on the low channel (the carrier with a lower frequency value).
- In dual channel mode the receiver always listens to both channels. As soon as it detects a valid frame on a channel, it stops listening to the other channel.

In addition, during reception, each channel supports only a single modulation at a time, which can be one of the two listed below:

1. Any of the PSK modulations (specified by the mode field in PSK physical frame, [Section 9.1.2](#))
2. FSK modulation, using the current FSK settings.

[Table 12](#) shows the allowed combinations for single channel and dual channel reception mode. Note that in case of FSK modulation on one channel and PSK on the other, the maximum FSK symbol rate is limited to 2400 baud.

Table 12. ST7580 allowed settings combination for reception

Reception mode	High channel	Low channel
Single channel receiver	Any PSK	-
	Selected FSK	-
Dual channel receiver	Any PSK	Any PSK
	Selected FSK (≤ 2400 baud)	Any PSK
	Any PSK	Selected FSK (≤ 2400 baud)

10 Data link layer

The data link layer implemented in the ST7580 provides some basic services:

- Encapsulation of user payloads into frames and frame delimitation
- Error detection and cancelling of corrupted frames
- Sniffer functionality for corrupted frames
- Encryption and authentication based on AES 128-bit algorithm
- Traffic statistics.

10.1 Data link frame

Figure 15 shows the data link frame structure:

Figure 15. Data link frame structure (length in bytes)

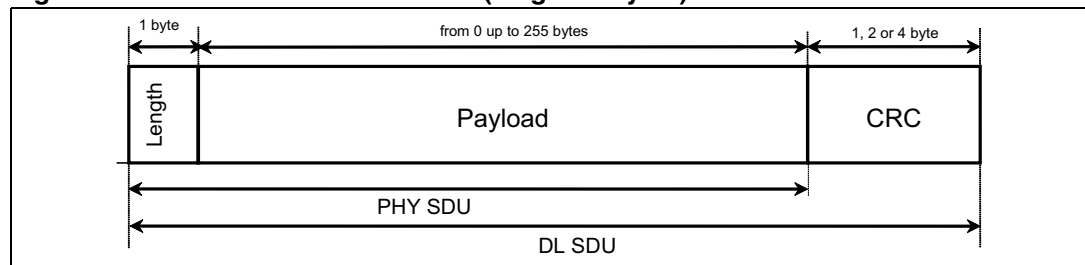

The meaning of each field is as follows:

- Length: length in bytes of the payload and CRC fields
- Payload: information bytes
- CRC: CRC check. Its length, endianness and the fields involved in the calculation (length and payload, or payload only) can be chosen by the external host.

10.2 Error detection and sniffer mode

The ST7580 data link layer uses a CRC code for error detection. The data link layer computes the CRC field and builds the frames for transmitting frames.

When receiving, it computes a CRC on the received data and compares it against the received CRC: it accepts the incoming frame only if the two values are equal. A further feature of reception configuration is the sniffer flag: if activated, the ST7580 notifies the host about frames received with wrong CRC also.

10.3 Security services

The ST7580 is able to encrypt / decrypt frames (on DL payload) through algorithms based on AES with 128-bit keys. A dedicated key that can be read and written by the external host is used for both transmitting and receiving frames.

11 Package mechanical data

In order to meet environmental requirements, ST offers these devices in different grades of ECOPACK® packages, depending on their level of environmental compliance. ECOPACK specifications, grade definitions and product status are available at: www.st.com. ECOPACK is an ST trademark.

The ST7580 is hosted in a 48-pin thermally enhanced, very thin, fine pitch quad flat package no lead (VFQFPN) with exposed pad, which allows the device to dissipate the heat that is generated by the operation of the two linear regulators and the power amplifier.

Table 13. VFQFPN48 (7 x 7 x 1.0 mm) package mechanical data

Dim.	(mm)		
	Min.	Typ.	Max.
A	0.80	0.90	1.00
A1		0.02	0.05
A2		0.65	1.00
A3		0.25	
b	0.18	0.23	0.30
D	6.85	7.00	7.15
D2	4.95	5.10	5.25
E	6.85	7.00	7.15
E2	4.95	5.10	5.25
e	0.45	0.50	0.55
L	0.30	0.40	0.50
ddd		0.08	

Figure 16. VFQFPN48 (7 x 7 x 1.0 mm) package outline

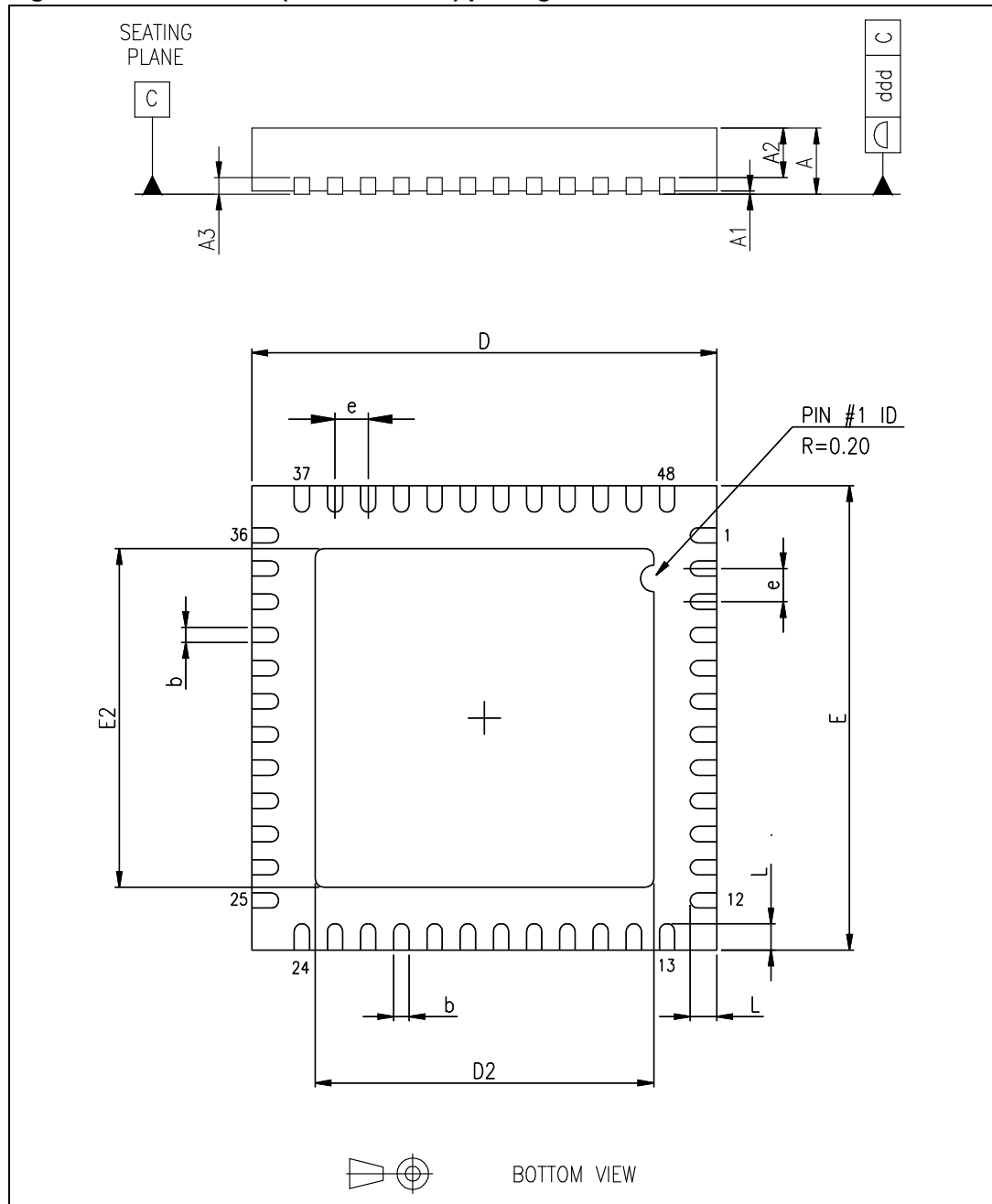

12 Revision history

Table 14. Document revision history

Date	Revision	Changes
26-Jan-2012	1	Initial release.

Please Read Carefully:

Information in this document is provided solely in connection with ST products. STMicroelectronics NV and its subsidiaries ("ST") reserve the right to make changes, corrections, modifications or improvements, to this document, and the products and services described herein at any time, without notice.

All ST products are sold pursuant to ST's terms and conditions of sale.

Purchasers are solely responsible for the choice, selection and use of the ST products and services described herein, and ST assumes no liability whatsoever relating to the choice, selection or use of the ST products and services described herein.

No license, express or implied, by estoppel or otherwise, to any intellectual property rights is granted under this document. If any part of this document refers to any third party products or services it shall not be deemed a license grant by ST for the use of such third party products or services, or any intellectual property contained therein or considered as a warranty covering the use in any manner whatsoever of such third party products or services or any intellectual property contained therein.

UNLESS OTHERWISE SET FORTH IN ST'S TERMS AND CONDITIONS OF SALE ST DISCLAIMS ANY EXPRESS OR IMPLIED WARRANTY WITH RESPECT TO THE USE AND/OR SALE OF ST PRODUCTS INCLUDING WITHOUT LIMITATION IMPLIED WARRANTIES OF MERCHANTABILITY, FITNESS FOR A PARTICULAR PURPOSE (AND THEIR EQUIVALENTS UNDER THE LAWS OF ANY JURISDICTION), OR INFRINGEMENT OF ANY PATENT, COPYRIGHT OR OTHER INTELLECTUAL PROPERTY RIGHT.

UNLESS EXPRESSLY APPROVED IN WRITING BY TWO AUTHORIZED ST REPRESENTATIVES, ST PRODUCTS ARE NOT RECOMMENDED, AUTHORIZED OR WARRANTED FOR USE IN MILITARY, AIR CRAFT, SPACE, LIFE SAVING, OR LIFE SUSTAINING APPLICATIONS, NOR IN PRODUCTS OR SYSTEMS WHERE FAILURE OR MALFUNCTION MAY RESULT IN PERSONAL INJURY, DEATH, OR SEVERE PROPERTY OR ENVIRONMENTAL DAMAGE. ST PRODUCTS WHICH ARE NOT SPECIFIED AS "AUTOMOTIVE GRADE" MAY ONLY BE USED IN AUTOMOTIVE APPLICATIONS AT USER'S OWN RISK.

Resale of ST products with provisions different from the statements and/or technical features set forth in this document shall immediately void any warranty granted by ST for the ST product or service described herein and shall not create or extend in any manner whatsoever, any liability of ST.

ST and the ST logo are trademarks or registered trademarks of ST in various countries.

Information in this document supersedes and replaces all information previously supplied.

The ST logo is a registered trademark of STMicroelectronics. All other names are the property of their respective owners.

© 2012 STMicroelectronics - All rights reserved

STMicroelectronics group of companies

Australia - Belgium - Brazil - Canada - China - Czech Republic - Finland - France - Germany - Hong Kong - India - Israel - Italy - Japan - Malaysia - Malta - Morocco - Philippines - Singapore - Spain - Sweden - Switzerland - United Kingdom - United States of America

www.st.com