

FSK power line transceiver

General features

- Half-duplex frequency shift keying (FSK) transceiver
- Integrated power line driver with programmable voltage and current control
- Programmable mains access:
 - Synchronous
 - Asynchronous
- Single supply voltage (from 7.5V up to 13.5V)
- Very low power consumption ($I_q = 5\text{mA}$)
- Integrates 5V voltage regulator (up to 50mA) with short circuit protection
- Integrated 3.3V voltage regulator (up to 50mA) with short circuit protection
- 3.3V or 5V digital supply
- 8 Programmable transmission frequencies
- Programmable baud rate up to 4800BPS
- Receiving sensitivity up to $250\mu\text{V}_{\text{RMS}}$
- Suitable for applications in accordance with EN 50065 Cenelec specification
- Carrier or preamble detection
- Band in use detection
- Programmable control register
- Watchdog timer
- 8 or 16 Bit header recognition
- ST7537 and ST7538 compatible
- UART/SPI host interface



Description

The ST7540 is a Half Duplex synchronous/asynchronous FSK Modem designed for power line communication network applications. It operates from a single supply voltage and integrates a line driver and two linear regulators for 5V and 3.3V. The device operation is controlled by means of an internal register, programmable through the synchronous serial interface. Additional functions as watchdog, clock output, output voltage and current control, preamble detection, time-out and band in use are included. Realized in Multipower BCD5 technology that allows to integrate DMOS, Bipolar and CMOS structures in the same chip.

Order codes

Part number	Package	Packaging
ST7540	HTSSOP28 (Exposed Pad)	Tube
ST7540TR	HTSSOP28 (Exposed Pad)	Tape and reel

Contents

- 1 Block diagram 4**
- 2 Pin settings 5**
 - 2.1 Pin connection 5
 - 2.2 Pin description 5
- 3 Electrical data 7**
 - 3.1 Maximum ratings 7
 - 3.2 Thermal data 7
 - 3.3 Recommended operating conditions 8
- 4 Electrical characteristics 9**
- 5 Crystal resonator and external clock 15**
- 6 Functional description 16**
 - 6.1 Carrier frequencies 16
 - 6.2 Baud rates 16
 - 6.3 Mark and space frequencies 17
 - 6.4 ST7540 Mains access 18
 - 6.5 Host processor interface 19
 - 6.5.1 Communication between Host and ST7540 20
 - 6.5.2 Control register access 22
 - 6.6 Receiving mode 23
 - 6.7 Transmission mode 26
 - 6.8 Control register 32

7	Auxiliary analog and digital functions	36
7.1	Band in use	36
7.2	Time out	36
7.3	Reset & watchdog	37
7.4	Output clock	37
7.5	Output voltage level freeze	37
7.6	Extended control register	37
7.7	Under voltage lock out	38
7.8	Thermal shutdown	38
7.9	5V Voltage regulator	38
7.10	3.3V Voltage regulator	38
7.11	Power-up procedure	38
8	Mechanical data	41
9	Revision history	43

1 Block diagram

Figure 1. Block diagram

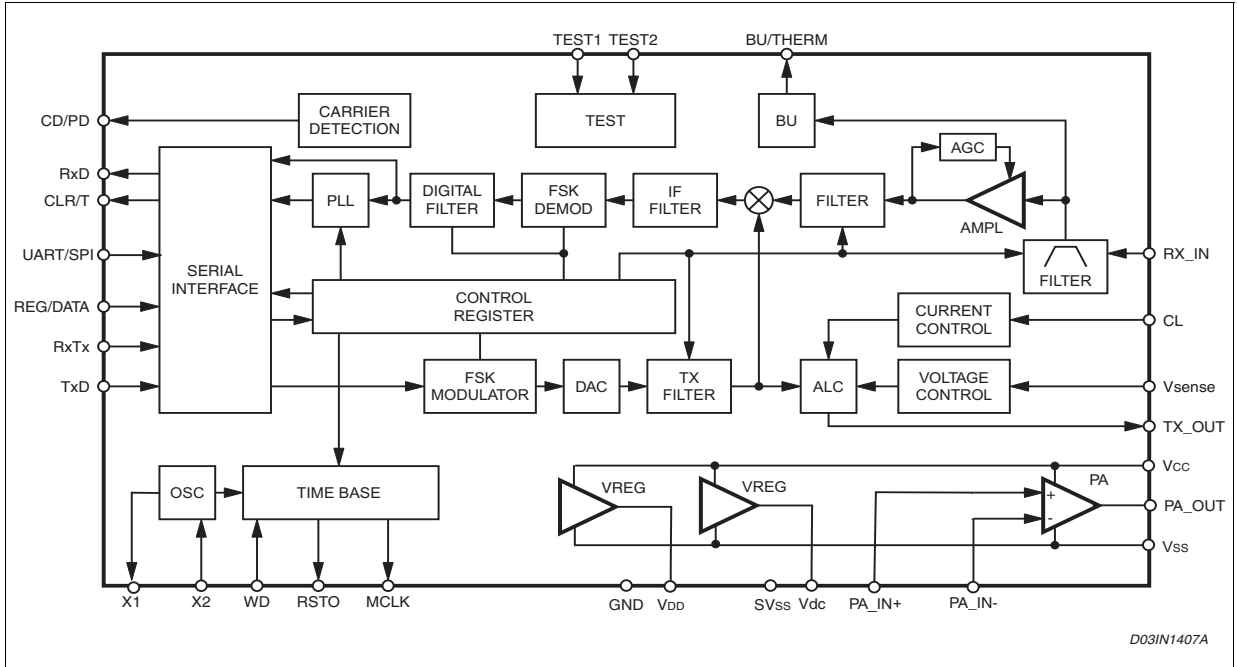

D03IN1407A

2 Pin settings

2.1 Pin connection

Figure 2. Pin connection (top view)

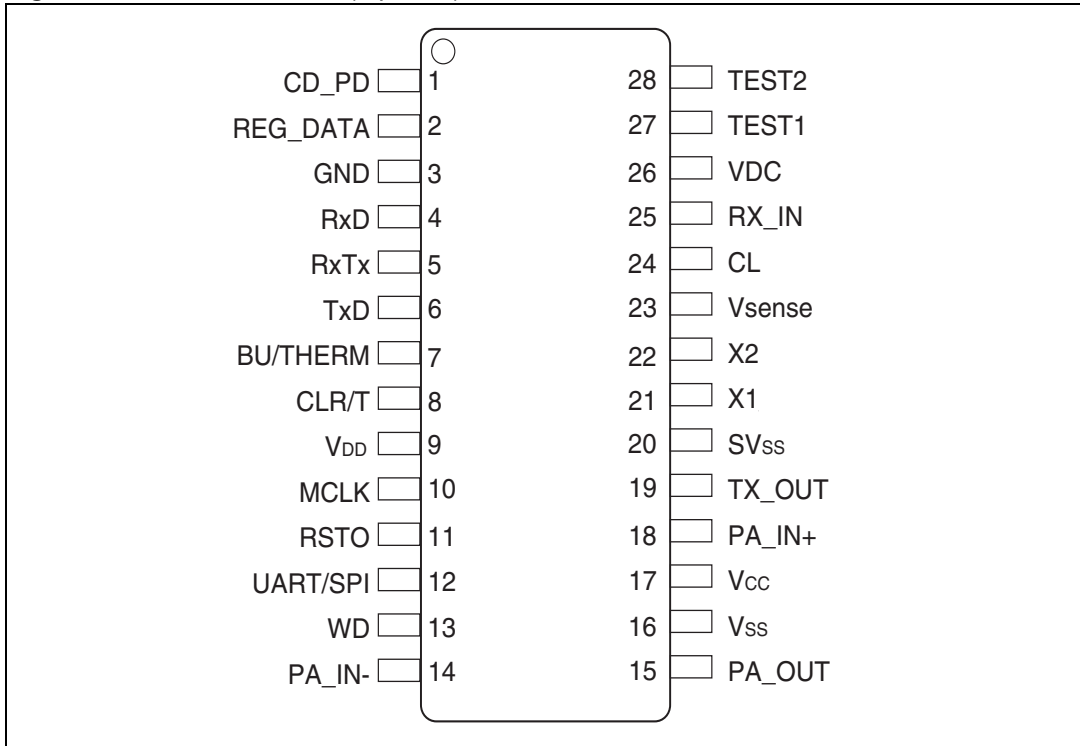

2.2 Pin description

Table 1. Pin description

N°	Name	Type	Description
1	CD_PD	Digital/Output	Carrier, preamble or frame header detect output. "1" No carrier, preamble or frame header detected "0" Carrier, preamble or frame header detected
2	REG_DATA	Digital/Input with internal pull-down	Mains or control register access selector "1" - Control register access "0" - Mains access
3	GND	Supply	Digital ground
4	RxD	Digital/Output	RX data output.
5	RxTx	Digital/Input with internal pull-up	Rx or Tx mode selection input. "1" - RX Session "0" - TX Session
6	TxD	Digital/Input with internal pull-down	TX data input.

Table 1. Pin description (continued)

N°	Name	Type	Description
7	BU/THERM	Digital/Output	Band in use/Thermal Shutdown event detection output. In Rx mode: "1" Signal within the programmed band "0" No signal within the programmed band In Tx mode: "1" - Thermal Shutdown event occurred "0" - No Thermal Shutdown event occurred (signal not latched)
8	CLR/T	Digital/Output	Synchronous mains access clock or control register access clock
9	V _{DD}	Supply/Power	Digital supply voltage or 3.3V voltage regulator output
10	MCLK	Digital/Output	Master clock output
11	RSTO	Digital/Output	Power ON or watchdog reset output
12	UART/SPI	Digital/Input with internal pull-down	Interface type: "0" - Serial peripheral interface "1" - UART interface
13	WD	Digital/Input with internal pull-up	Watchdog input. The internal watchdog counter is cleared on the falling edges.
14	PA_IN-	Analog/Input	Power line amplifier inverting input
15	PA_OUT	Power/Output	Power line amplifier output
16	V _{SS}	Supply	Power analog ground
17	V _{CC}	Supply	Power supply voltage
18	PA_IN+	Analog/Input	Power line amplifier not inverting input
19	TX_OUT	Analog/Output	Small signal analog transmit output
20	SV _{SS}	Supply	Analog signal ground
21	X1	Analog/Output	Crystal oscillator output
22	X2	Analog/Input	Crystal oscillator input - or external clock input
23	V _{SENSE} ⁽¹⁾	Analog/Input	Output voltage sensing input for the voltage control loop
24	CL ⁽²⁾	Analog/Input	Current limiting feedback. A resistor between CL and SV _{SS} sets the PLI current limiting value. An integrated 80pF filtering input capacitance is present on this pin.
25	RX_IN	Analog/Input	Receiving analog input
26	VDC	Power	5V voltage regulator output
27	TEST1	Digital/Input with internal pull-down	Test input. Must be connected to GND.
28	TEST2	Analog/Input	Test input. Must be connected SV _{SS}

1. Cannot be left floating

2. Cannot be left floating

3 Electrical data

3.1 Maximum ratings

Table 2. Absolute maximum ratings

Symbol	Parameter	Value	Unit
V_{CC}	Power supply voltage	-0.3 to + 14	V
V_{DD}	Digital supply voltage	-0.3 to +5.5	V
SV_{SS}/GND	Voltage between SV_{SS} and GND	-0.3 to +0.3	V
V_I	Digital input voltage	GND - 0.3 to $V_{DD} + 0.3$	V
V_O	Digital output voltage	GND - 0.3 to $V_{DD} + 0.3$	V
I_O	Digital output current	-2 to +2	mA
$V_{sense}, X2, PA_IN-, PA_IN+, CL$	Voltage range at $V_{sense}, X2, PA_IN-, PA_IN+, CL$ Inputs	$SV_{SS} - 0.3$ to 5.6	V
RX_IN	Voltage range at RX_IN input	-5.6 to 5.6	V
TX_OUT, X1	Voltage range at TX_OUT, X1 outputs	$SV_{SS} - 0.3$ to 5.6	V
PA_OUT	Voltage range at powered PA_OUT Output	$V_{SS} - 0.3$ to $+V_{CC} + 0.3$	V
$I(PA_OUT)$	Power line driver output current ⁽¹⁾	650	mA _{rms}
T_A	Operating ambient temperature	-40 to +85	°C
T_{STG}	Storage temperature	-50 to 150	°C
RxD, PA_OUT Pin	Maximum withstanding voltage range Test condition: CDF-AEC-Q100-002- "Human Body Model"	±1750	V
Other pins	Acceptance criteria: "Normal Performance"	±2000	V

1. This current is intended as not repetitive pulse current

3.2 Thermal data

Table 3. Thermal data

Symbol	Parameter	HTSSOP28 Exposed Pad	Unit
R_{thJA1}	Maximum thermal resistance junction-ambient steady state ⁽¹⁾	35	°C/W
R_{thJA2}	Maximum thermal resistance junction-ambient Steady State ⁽²⁾	70	°C/W

1. Mounted on Multilayer PCB with a dissipating surface on the bottom side of the PCB

2. It is the same condition of the point above, without any heatsinking surface on the board.

3.3 Recommended operating conditions

Table 4. Recommended operating conditions

Symbol	Parameter	Test Condition	Value	Unit
V_{CC}	Max allowed slope during Power-up		100	V/ms
$I(V_{CC})$	Powered analog supply Current with digital supply provided externally	Maximum total current	650	mArms
$V_{CC} - V_{DD}$	Maximum voltage Difference between V_{CC} and V_{DD} during power-up sequence	$V_{DD} < 4.75V$ with 5V Digital supply provided externally	1.2	V
V_{PA_OUT}	Output voltage swing for PA_OUT pin		$V_{CC}-4.5$	V_{PP}
$I(PA_OUT)$	Maximum output transmitting current in programmable current limiting	$R_{cl} = 1.4k\Omega$; $R_{LOAD} = 1\Omega$ (as in Figure 17)	500	mArms

4 Electrical characteristics

Table 5. Electrical characteristics

($V_{DD} = +5V$, $V_{CC} = +9V$, $V_{SS} = SV_{SS} = GND = 0V$, $-40^{\circ}C \leq T_A \leq 85^{\circ}C$, $T_J < 125^{\circ}C$, unless otherwise specified)

Symbol	Parameter	Test condition	Min.	Typ.	Max.	Unit
V_{DD}	Digital supply voltages	5V Digital supply provided externally	4.75	5	5.25	V
V_{CC}	Power supply voltage		7.5		13.5	V
$I(V_{DD})$	Digital input supply current	Transmission & receiving mode (MCLK = 4MHz), no load			3.5	mA
		Transmission & Receiving mode (MCLK = OFF), no load			1.5	mA
$I(V_{CC})$	Power supply current with digital supply provided externally	TX mode, no load			60	mArms
		RX mode			5	mArms
UVLO	Under voltage lock out Threshold on V_{CC}		3.7	3.9	4.1	V
UVLO _{HYS}	UVLO Hysteresis on V_{CC}			340		mV

Digital I/O

R_{down}	Internal pull down resistor		-30%	100	+30%	k Ω
R_{up}	Internal pull up resistor		-30%	100	+30%	k Ω

Digital I/O - 5V digital supply

V_{IH}	High logic level input voltage		2			V
V_{IL}	Low logic level input voltage				1.2	V
V_{OH}	High logic level output voltage	$I_{OH} = -2mA$	$V_{DD} - 0.45$			V
V_{OL}	Low logic level output voltage	$I_{OL} = 2mA$			GND + 0.3	V

Digital I/O - 3.3V digital supply

V_{IH}	High logic level input voltage		1.4			V
V_{IL}	Low logic level input voltage				0.8	V

Table 5. Electrical characteristics (continued)

($V_{DD} = +5V$, $V_{CC} = +9V$, $V_{SS} = SV_{SS} = GND = 0V$, $-40^{\circ}C \leq T_A \leq 85^{\circ}C$, $T_J < 125^{\circ}C$, unless otherwise specified)

Symbol	Parameter	Test condition	Min.	Typ.	Max.	Unit
V_{OH}	High logic level output voltage	$I_{OH} = -2mA$	$V_{DD} - 0.75$			V
V_{OL}	Low logic level output voltage	$I_{OL} = 2mA$			GND + 0.4	V
Oscillator						
External Clock	X2 voltage swing	External clock. Figure 4		5		V_{pp}
External Clock	X2 DC voltage level	External clock. Figure 4		2.5		V
DC	XTAL Clock duty cycle	External clock.	40		60	%
Xtal	Crystal oscillator frequency	fundamental	16			MHz
$Xtal_{ESR}$	External oscillator esr resistance				40	Ω
$Xtal_{CL}$	External oscillator stabilization capacitance	Figure 6			16	pF
Transmitter						
I_{TX_OUT}	Output transmitting current on TX_OUT				1	mArms
V_{TX_OUT}	Max carrier output AC voltage	$R_{CL} = 1.4k\Omega$ $V_{sense} = 0V$	1.75	2.3	3.5	V_{PP}
V_{TX_OUTDC}	Output DC voltage on TX_OUT		1.7	2.1	2.5	V
HD2 _{TX_OUT}	Second harmonic distortion on TX_OUT	$V_{TX_OUT} = 2V_{PP}$; $F_c = 86KHz$, no load			-42	dB _c
HD3 _{TX_OUT}	Third harmonic distortion on TX_OUT	$V_{TX_OUT} = 2V_{PP}$; $F_c = 86KHz$, no load			-49	dB _c
G accuracy	Accuracy on voltage control loop active	$R_{CL} = 0\Omega$	-1		+1	GST
G_{ST}	ALC gain step control loop gain step		0.6	1	1.4	dB
DRNG	ALC dynamic range			30		dB
C_{CL}	Input capacitance on CL pin			80		pF
$V_{senseTH}$	Voltage control loop reference threshold on V_{sense} pin	Figure 17	160	180	200	mV _{PK}
$V_{senseHYST}$	Hysteresis on voltage loop reference threshold	Figure 17		± 18		mV

Table 5. Electrical characteristics (continued)

($V_{DD} = +5V$, $V_{CC} = +9V$, $V_{SS} = SV_{SS} = GND = 0V$, $-40^{\circ}C \leq T_A \leq 85^{\circ}C$, $T_J < 125^{\circ}C$, unless otherwise specified)

Symbol	Parameter	Test condition	Min.	Typ.	Max.	Unit
V_{SENSE}	V_{SENSE} Input impedance			36		k Ω
CL_{TH}	Current control loop reference threshold on CL pin	Figure 17	1.80	1.90	2.00	V
CL_{HYST}	Hysteresis on current loop reference threshold	Figure 17	210	250	290	mV
T_{RXTx}	Carrier activation time	Figure 21 - 600 Baud Xtal = 16MHz			1.6	ms
		Figure 21- 1200 Baud Xtal = 16MHz			800	μ s
		Figure 21- 2400 Baud Xtal = 16MHz			400	μ s
		Figure 21- 4800 Baud Xtal = 16MHz			200	μ s
T_{ALC}	Carrier stabilization time from STEP 16 to zero or from step 16 to step 31,	Figure 21 Xtal = 16MHz			3.2	ms
T_{ST}	Tstep	Figure 21 Xtal = 16MHz			200	μ s
Power amplifier						
$PA_{IN(Offset)}$	Input terminals OFFSET			± 18		mV
GBWP	Gain bandwidth product		100			MHz
R_{IN}	Input resistance at PA_IN+ and PA_IN- pins	PA_IN+ vs. Vss ⁽¹⁾	1			M Ω
		PA_IN- vs. Vss ⁽¹⁾	1			M Ω
C_{IN}	Input capacitance at PA_IN+ and PA_IN- pins	PA_IN+ vs. Vss ⁽¹⁾		5		pF
		PA_IN- vs. Vss ⁽¹⁾		5		pF
CMRR	Common mode rejection ratio			40		dB

Table 5. Electrical characteristics (continued)

($V_{DD} = +5V$, $V_{CC} = +9V$, $V_{SS} = SV_{SS} = GND = 0V$, $-40^{\circ}C \leq T_A \leq 85^{\circ}C$, $T_J < 125^{\circ}C$, unless otherwise specified)

Symbol	Parameter	Test condition	Min.	Typ.	Max.	Unit
HD2 _{PA_OUT}	Second harmonic distortion on PA_OUT	$V_{PA_OUT} = 5.6V_{PP}$, $V_{CC} = 12V$ $R_{LOAD} = 30\Omega$ Carrier frequency: 86KHz <i>Figure 3</i>			-63	dB _c
HD3 _{PA_OUT}	Third harmonic distortion on PA_OUT pin	$V_{PA_OUT} = 5.6V_{PP}$, $V_{CC} = 12V$ $R_{LOAD} = 30\Omega$ Carrier frequency: 86KHz <i>Figure 3</i>			-63	dB _c

Receiver

V _{IN}	Input sensitivity (Normal Mode)			0.5	2	mV _{rms}
	Input sensitivity (High Sens.)			250		μV _{rms}
	Input sensitivity (TxD line forced to "1")			V _{BU}		dB/ μV _{rms}
V _{IN}	Maximum input signal				2	V _{rms}
R _{IN}	Input impedance		80	100	140	kΩ
V _{CD}	Carrier detection sensitivity (Normal Mode)			0.5	2	mV _{rms}
	Carrier detection sensitivity (High Sensitivity Mode)			250		μV _{rms}
	Carrier detection sensitivity (TxD forced to "1")			V _{BU}		dB/ μV _{rms}
V _{BU}	Band in Use Detection Level			83.5	86	dB/ μV _{rms}

Table 5. Electrical characteristics (continued)

($V_{DD} = +5V$, $V_{CC} = +9V$, $V_{SS} = SV_{SS} = GND = 0V$, $-40^{\circ}C \leq T_A \leq 85^{\circ}C$, $T_J < 125^{\circ}C$, unless otherwise specified)

Symbol	Parameter	Test condition	Min.	Typ.	Max.	Unit
5V Voltage regulator						
VDC	Linear regulator output voltage	$0 < I_o < 50mA$ $7.5V < V_{CC} < 13.5V$	-5%	5.05	+5%	V
3.3V Voltage regulator						
V _{DD}	Linear regulator output voltage	$0 < I_o < 50mA$ $7.5V < V_{CC} < 13.5V$	-5%	3.3	+5%	V
Other functions						
T _{RSTO}	Reset time	See Figure 23 ; Xtal = 16MHz	50			ms
T _{WD}	Watch-dog pulse width	See Figure 23	125			ns
T _{WM}	Watch-dog pulse period	Minimum value. See Figure 23	250			ns
		Maximum value. See Figure 23			1490	ms
T _{WO}	Watch-dog time out	See Figure 23			1.5	s
T _{OUT}	TX time out	Control register bit 7 and bit 8		1 3		s
T _{OFF}	Time Out OFF time	Figure 22	125			ms
T _{OFFD}	RxTx 0->1 vs. time out delay	Figure 22			20	μs
T _{CD}	Carrier detection time selectable by register	Control register bit 9 and bit10 Figure 14		500 1 3 5		μs ms ms ms
T _{DCD}	CD_PD Propagation delay	Figure 14		300	500	μs
M _{CLK}	Master clock output selectable by register	Control register bit 15 and bit 16 See Table 12		fclock fclock/2 fclock/4 off		MHz
BAUD	Baud rate	Control register bit 3 and bit 4 See Table 12		600 1200 2400 4800		Baud

Table 5. Electrical characteristics (continued)

($V_{DD} = +5V$, $V_{CC} = +9V$, $V_{SS} = SV_{SS} = GND = 0V$, $-40^{\circ}C \leq T_A \leq 85^{\circ}C$, $T_J < 125^{\circ}C$, unless otherwise specified)

Symbol	Parameter	Test condition	Min.	Typ.	Max.	Unit
Serial Interface						
T_B	Baud rate Bit Time (1/BAUD)	Control register bit 3 and bit 4 (See Figure 13)		1667 833 417 208		μs
T_s	Setup time	see Figures 8, 9, 10, 11 & 12			5	ns
T_H	Hold time	see Figures 8, 9, 10, 11 & 12			2	ns
T_{CR}	CLR/T vs. REG_DATA or RxTx	see Figures 8, 9, 10, 11 & 12			$T_B/4$	
T_{CC}	CLR/T vs. CLR/T	see Figures 8, 9, 10, 11 & 12	T_B		$2 * T_B$	
T_{DS}	Setup time	see Figures 8, 9, 10, 11 & 12	$T_B/4$		$T_B/2$	
T_{DH}	Hold time	see Figures 8, 9, 10, 11 & 12	$T_B/4$		$T_B/2$	
T_{CRP}			T_H		$T_B/2$	

1. Not tested, guaranteed by design

Figure 3. PLI configuration for PA_OUT distortions measurement

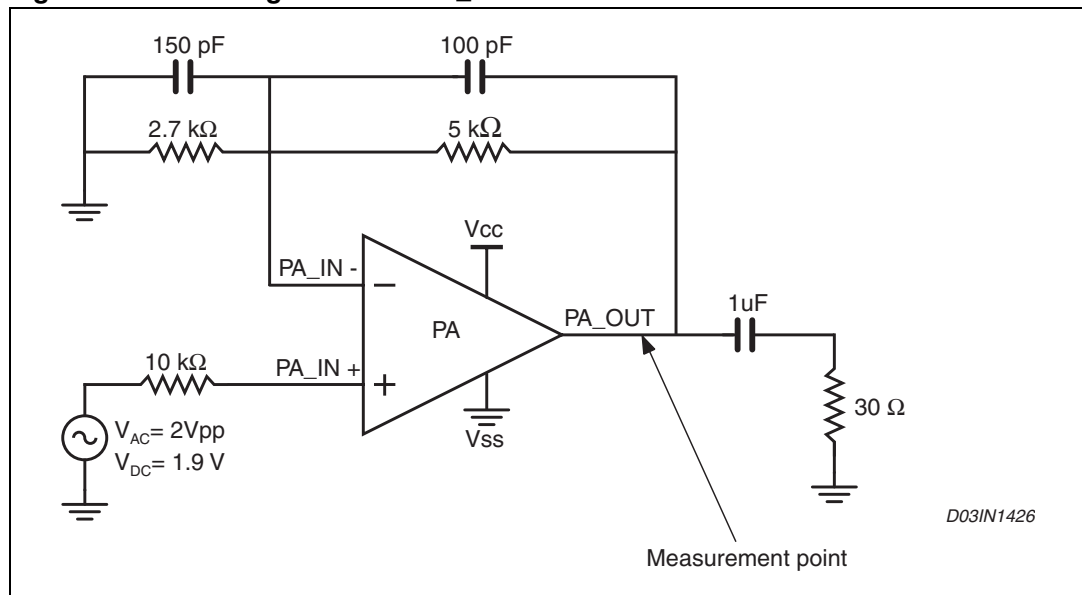

5 Crystal resonator and external clock

Figure 4. External clock waveform

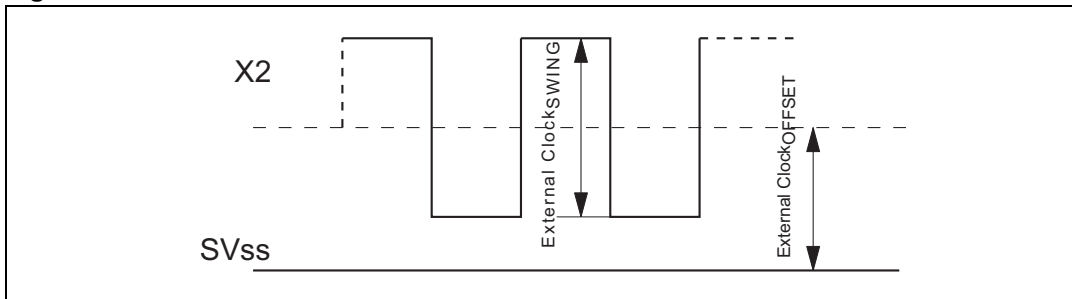
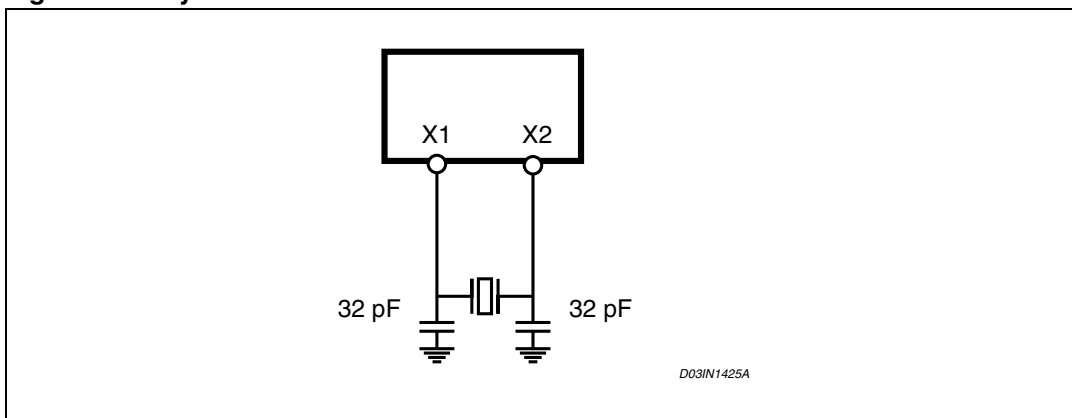

Figure 5. Crystal Resonator



6 Functional description

6.1 Carrier frequencies

ST7540 is a multi frequency device: eight programmable Carrier Frequencies are available (see [Table 6](#)).

Only one Carrier can be used a time. The communication channel could be varied during the normal working Mode to realize a multi frequency communication.

Selecting the desired frequency in the Control Register the Transmission and Reception filters are accordingly tuned.

Table 6. Channels List

FCarrier	F (KHz)
F0	60
F1	66
F2	72
F3	76
F4	82.05
F5	86
F6	110
F7 ⁽¹⁾	132.5

1. Default value

6.2 Baud rates

ST7540 is a multi Baud rate device: four Baud Rate are available (See [Table 8](#)).

Table 7. ST7540 mark and space tones frequency distance Vs. baud rate and deviation

Baud Rate [Baud]	ΔF ⁽¹⁾ (Hz)	Deviation ⁽²⁾
600	600	1 ⁽³⁾
1200	600 1200	0.5 1
2400 ⁽⁴⁾	1200 ⁽⁴⁾ 2400	0.5 1
4800	2400 4800	0.5 1

1. Frequency deviation

2. Deviation = $\Delta F / (\text{Baud Rate})$

3. Deviation 0.5 not allowed

4. Default value

6.3 Mark and space frequencies

Mark and Space Communication Frequencies are defined by the following formula:

$$F ("0") = F_{\text{Carrier}} + [\Delta F]/2$$

$$F ("1") = F_{\text{Carrier}} - [\Delta F]/2$$

ΔF is the Frequency Deviation.

With Deviation = "0.5" the difference in terms of frequency between the mark and space tones is half the Baudrate value ($\Delta F=0.5 \cdot \text{BAudrate}$). When the Deviation = "1" the difference is the Baudrate itself ($\Delta F = \text{Baudrate}$). The minimal Frequency Deviation is 600Hz.

Table 8. ST7540 synthesized frequencies

Carrier frequency (KHz)	Baud rate	Deviation	Exact frequency [Hz] (Clock=16MHz)		Carrier frequency (KHz)	Baud rate	Deviation	Exact frequency [Hz] (Clock=16MHz)	
			"1"	"0"				"1"	"0"
60	600	--			82.05	600	--		
		1	59733	60221			1	81706	82357
	1200	0.5	59733	60221		1200	0.5	81706	82357
		1	59408	60547			1	81380	82682
	2400	0.5	59408	60547		2400	0.5	81380	82682
		1	58757	61198			1	80892	83171
	4800	0.5	58757	61198		4800	0.5	80892	83171
		1	57617	62337			1	79590	84473
66	600	--			86	600	--		
		1	65755	66243			1	85775	86263
	1200	0.5	65755	66243		1200	0.5	85775	86263
		1	65430	66569			1	85449	86589
	2400	0.5	65430	66569		2400	0.5	85449	86589
		1	64779	67220			1	84798	87240
	4800	0.5	64779	67220		4800	0.5	84798	87240
		1	63639	68359			1	83659	88379
72	600	--			110	600	--		
		1	71777	72266			1	109701	110352
	1200	0.5	71777	72266		1200	0.5	109701	110352
		1	71452	72591			1	109375	110677
	2400	0.5	71452	72591		2400	0.5	109375	110677
		1	70801	73242			1	108724	111165
	4800	0.5	70801	73242		4800	0.5	108724	111165
		1	69661	74382			1	107585	112467

Table 8. ST7540 synthesized frequencies

76	600	--			132.5	600	--		
		1	75684	76335			1	132161	132813
	1200	0.5	75684	76335		1200	0.5	132161	132813
		1	75358	76660			1	131836	133138
	2400	0.5	75358	76660		2400	0.5	131836	133138
		1	74870	77148			1	131348	133626
	4800	0.5	74870	77148		4800	0.5	131348	133626
		1	73568	78451			1	130046	134928

6.4 ST7540 Mains access

ST7540 can access the Mains in two different ways:

- Synchronous access
- Asynchronous access

The choice between the two types of access can be performed by means of Control Register bit 14(see [Table 12](#)) and affects the ST7540 data flow in Transmission Mode as in Reception Mode (for how to set the communication Mode, see [Section 6.5](#)).

In data transmission mode:

- Synchronous Mains access: on clock signal provided by ST7540 (CLR/T line) rising edge, data transmission line (TxD line) value is read and sent to the FSK Modulator. ST7540 manages the Transmission timing according to the BaudRate Selected.
- Asynchronous Mains access: data transmission line (TxD line) value enters directly to the FSK Modulator. The Host Controller manages the Transmission timing (CLR/T line should be neglected).

In data reception mode:

- Synchronous Mains access: on clock signal recovered by a PLL from ST7540 (CLR/T line) rising edge, value on FSK Demodulator is read and put to the data reception line (RxD line). ST7540 recovers the bit timing according to the BaudRate Selected.
- Asynchronous Mains access: Value on FSK Demodulator is sent directly to the data reception line (RxD line). The Host Controller recovers the communication timing (CLR/T line should be neglected).

6.5 Host processor interface

ST7540 exchanges data with the host processor through a serial interface.

The data transfer is managed by REG_DATA and RxTx Lines, while data are exchanged using RxD, TxD and CLR/T lines.

Four are the ST7540 working modes:

- Data Reception
- Data Transmission
- Control Register Read
- Control Register Write

REG_DATA and RxTx lines are level sensitive inputs.

Table 9. Data and Control register access bits configuration

	REG_DATA	RxTx
Data Transmission	0	0
Data Reception	0	1
Control Register Read	1	1
Control Register Write	1	0

ST7540 features two type of Host Communication Interfaces:

- SPI
- UART

The selection can be done through the UART/SPI pin. If UART/SPI pin is forced to “0” SPI interface is selected while if UART/SPI pin is forced to “1” UART interface is selected. The type of interface affects the Data Reception by setting the idle state of RxD line. When ST7540 is in Receiving mode (REG_DATA=“0” and RxTx =“1”) and no data are available on mains (or RxD is forced to an idle state, i.e. with a conditioned Detection Method), the RxD line is forced to “0” when UART/SPI pin is forced to “0” or it is forced to “1” when UART/SPI pin is forced to “1”.

The UART interface allows to connect an UART compatible device while SPI interface allows to connect an SPI compatible device. The allowed combinations of Host Interface/ST7540 Mains Access are:

Table 10. Host interface / ST7540 mains access combinations

Host device interface type	UART/SPI pin	Communication mode	Mains access	
			Asynchronous	Synchronous
UART	“1”	Transmission	X	
UART	“1”	Reception	X	
SPI	“0”	Transmission		X
SPI	“0”	Reception		X

Figure 6. Synchronous and Asynchronous ST7540/Host Controller interfaces

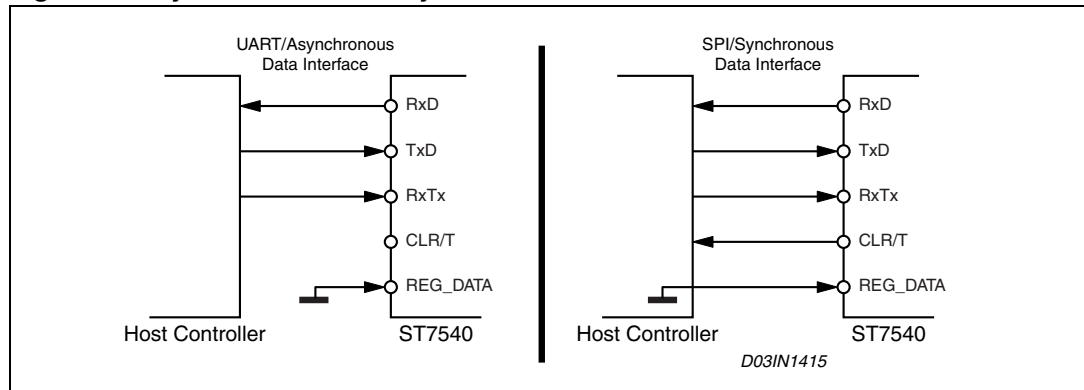

ST7540 allows to interface the Host Controller using a five line interface (RxD, TxD, RxTx, CLR/T, & REG_DATA) in case of Synchronous mains access or using a 3 line interface (RxD, TxD & RxTx) in Asynchronous mains access. Since Control Register is not accessible in Asynchronous mode, in this case REG_DATA pin must be tied to GND.

6.5.1 Communication between Host and ST7540

The Host can achieve the Mains access by selecting REG_DATA="0" and the choice between Data Transmission or Data Reception is performed by selecting RxTx line (if RxTx="1" ST7540 receives data from mains, if RxTx="0" ST7540 transmits data over the mains).

Communication between Host and ST7540 is different in Asynchronous and Synchronous mode:

- **Asynchronous mode:**

In Asynchronous Mode, data are exchanged without any data Clock reference. The host controller has to recover the clock reference in receiving Mode and control the Bit time in transmission mode.

If RxTx line is set to "1" & REG_DATA="0" (Data Reception), ST7540 enters in an Idle State. After Tcc time the modem starts providing received data on RxD line.

If RxTx line is set to "0" & REG_DATA="0" (Data Transmission), ST7540 enters in an Idle State and transmission circuitry is switched on. After Tcc time the modem starts transmitting data present on TxD line.

- **Synchronous mode:**

In Synchronous Mode ST7540 is always the master of the communication and provides the clock reference on CLR/T line. When ST7540 is in receiving mode an internal PLL recovers the clock reference. Data on RxD line are stable on CLR/T rising Edge.

When ST7540 is in transmitting mode the clock reference is internally generated and TxD line is sampled on CLR/T rising Edge.

If RxTx line is set to "1" & REG_DATA="0" (Data Reception), ST7540 enters in an Idle State and CLR/T line is forced Low. After T_{cc} time the modem starts providing received data on RxD line.

If RxTx line is set to "0" & REG_DATA="0" (Data Transmission), ST7540 enters in an Idle State and transmission circuitry is switched on. After T_{cc} time the modem starts transmitting data present on TxD line (Figure 8).

Figure 7. Receiving and transmitting data/recovered clock timing

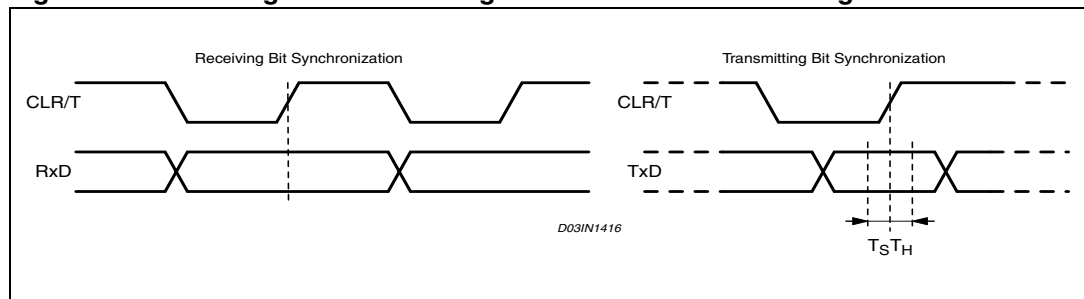
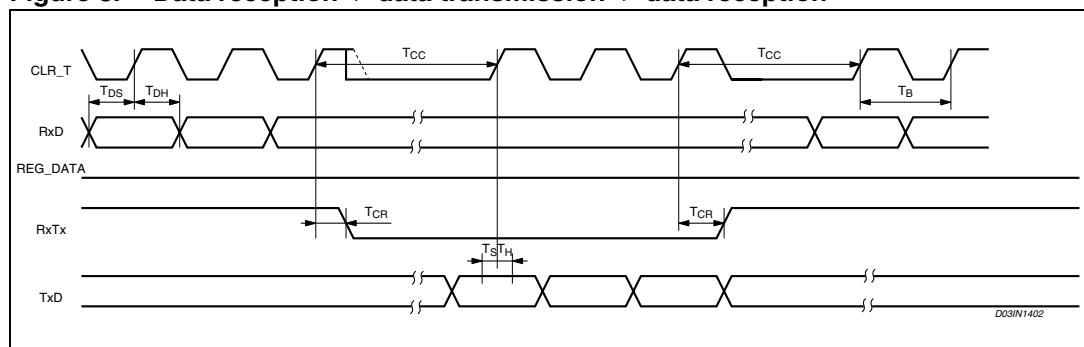

Figure 8. Data reception -> data transmission -> data reception



6.5.2 Control register access

The communication with ST7540 Control Register is always synchronous. The access is achieved using the same lines of the Mains interface (RxD, TxD, RxTx and CLR/T) plus REG_DATA Line.

With REG_DATA = 1 and RxTx = 0, the data present on TxD are loaded into the Control Register MSB first. The ST7540 samples the TxD line on CLR/T rising edges. The control Register content is updated at the end of the register access section (REG_DATA falling edge).

In Normal Control Register mode (Control Register bit 21 = "0", see [Table 12](#)) if more than 24 bits are transferred to ST7540 only latest 24 bits are stored inside the Control Register. If less than 24 bits are transferred to ST7540 the Control Register writing is aborted.

In order to avoid undesired Control Register writings caused by REG_DATA line fluctuations (for example because of surge or burst on mains), in Extended Control Register mode (Control Register bit 21 = "1" see [Table 12](#)) exactly 24 or 48 bits must be transferred to ST7540 in order to properly write the Control Register, otherwise writing is aborted. If 24 bits are transferred, only the first 24 Control Register bits (from 23 to 0) are written.

With REG_DATA = 1 and RxTx = 1, the content of the Control Register is sent on RxD port. The Data on RxD are stable on CLR/T rising edges MSB First. In Normal Control Register mode 24 bits are transferred from ST7540 to the Host. In Extended Control Register mode 24 or 48 bits are transferred from ST7540 to the Host depending on content of Control Register bit 18 (with bit 18 = "0" the first 24 bits are transferred, otherwise all 48 bits are transferred, see [Table 12](#)).

Figure 9. Data reception → control register read → data reception timing diagram

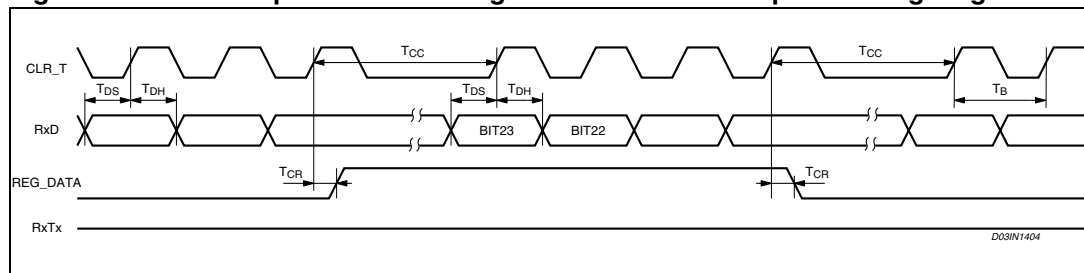

Figure 10. data reception → control register write → data reception timing diagram

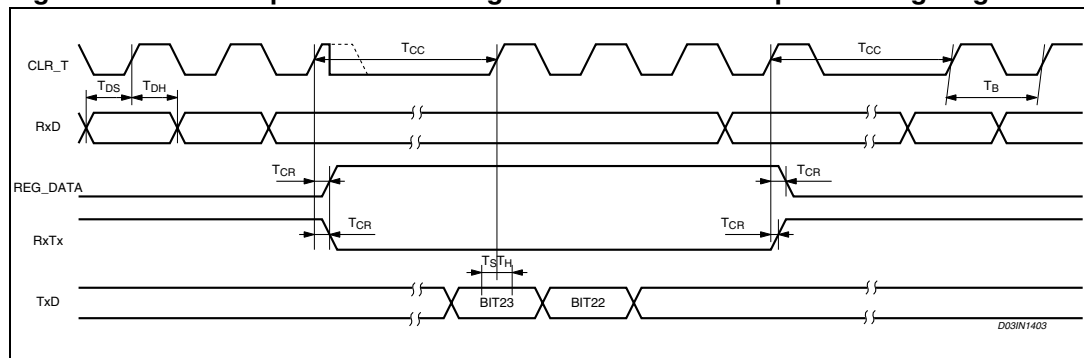

Figure 11. Data transmission → control register read → data reception timing diagram

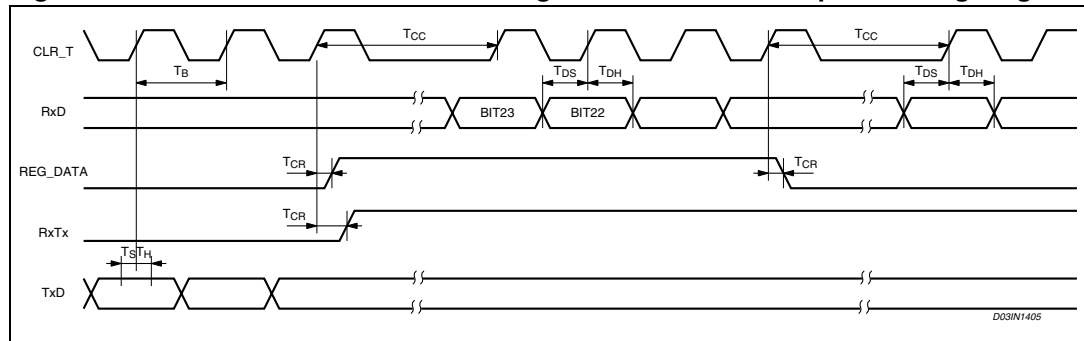
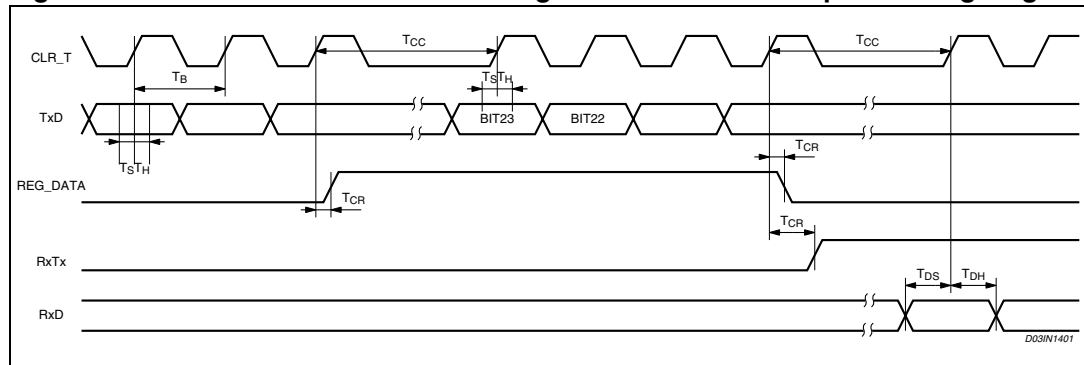

Figure 12. Data transmission → control register write → data reception timing diagram



6.6 Receiving mode

The receive section is active when RxD pin = "1" and REG_DATA=0.

The input signal is read on RX_IN Pin using SV_{SS} as ground reference and then pre-filtered by a Band pass Filter (62kHz max bandwidth at -3dB). The Pre-Filter can be inserted setting one bit in the Control Register. The Input Stage features a wide dynamic range to receive Signal with a Very Low Signal to Noise Ratio. The Amplitude of the applied waveform is automatically adapted by an Automatic Gain Control block (AGC) and then filtered by a Narrow Band Band-Pass Filter centered around the Selected Channel Frequency (14kHz max at -3dB). The resulting signal is down-converted by a mixer using a sinewave generated by the FSK Modulator. Finally an Intermediate Frequency Band Pass-Filter (IF Filter) improves the Signal to Noise ration before sending the signal to the FSK demodulator. The FSK demodulator then send the signal to the RX Logic for final digital filtering. Digital filtering Removes Noise spikes far from the BAUD rate frequency and Reduces the Signal Jitter. RxD Line is forced to "0" or "1" (according the UART/SPI pin level) when neither mark or space frequencies are detected on RX_IN Pin.

Mark and Space Frequency in Receiving Mode must be distant at least BaudRate/2 to have a correct demodulation.

While ST7540 is in Receiving Mode (RxD pin = "1"), the transmit circuitry, Power Line Interface included, is turned off. This allows the device to achieve a very low current consumption (5mA typ).

- **Receiving Sensitivity Level Selection**

It is possible to select the ST7540 Receiving Sensitivity Level by Control Register (see [Table 12](#)) or setting to '1' the TxD pin during reception phase (this condition overcomes the control register setting the sensitivity equal to BU threshold). Increasing the device sensitivity allows to improve the communication reliability when the ST7540 sensitivity is the limiting factor.

- **Synchronization Recovery System (PLL)**

ST7540 embeds a Clock Recovery System to feature a Synchronous data exchange with the Host Controller. The clock recovery system is realized by means of a second order PLL. In Synchronous mode, data on the data line (RxD) are stable on CLR/T line rising edge (CLR/T Falling edge synchronized to RxD line transitions \pm LOCK-IN Range). The PLL Lock-in and Lock-out Range is $\pm\pi/2$. When the PLL is in the unlock condition RxD line is forced to "0" or "1" according to the UART/SPI pin level and CLR/T is forced to "0" only if the Detection Method "Preamble Detection With Conditioning" is selected. When PLL is in unlock condition it is sensitive to RxD Rising and Falling Edges. The maximum number of transition required to reach the lock-in condition is 5. When in lock-in condition the PLL is sensitive only to RxD rising Edges to reduce the CLR/T Jitter. ST7540 PLL is forced in the un-lock condition, when more than 32 equal symbols are received. Due to the fact that the PLL, in lock-in condition, is sensitive only to RxD rising edge, sequences equal or longer than 15 equal symbols can put the PLL into the un-lock condition.

Figure 13. ST7540 PLL lock-in range

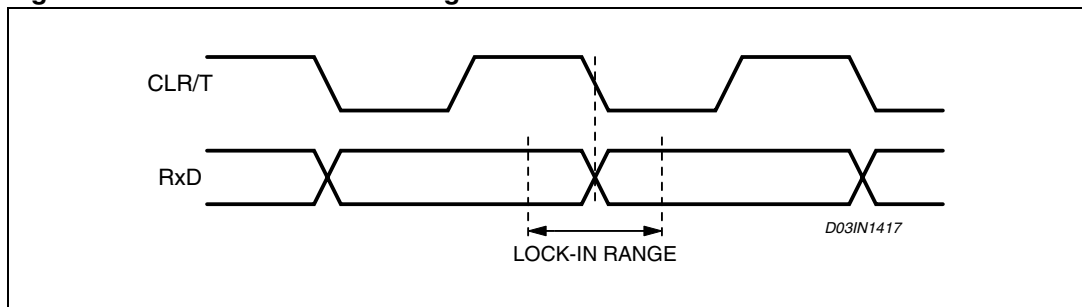

- **Carrier/Preamble Detection**

The Carrier/Preamble Block is a digital Frequency detector Circuit. It can be used to manage the MAINS access and to detect an incoming signal. Two are the possible setting:

- Carrier Detection
- Preamble Detection

- **Carrier Detection**

The Carrier/Preamble detection Block notifies to the host controller the presence of a Carrier when it detects on the RX_IN Input a signal with an harmonic component close to the programmed Carrier Frequency. The CD_PD signal sensitivity is identical to the data reception sensitivity (0.5mVrms Typ. in Normal Sensitivity Mode). When the device sensitivity is set by the TxD line (Sensitivity level equal to BU threshold) the CD_PD signal is conditioned to the BU signal.

The CD_PD line is forced to a logic level low when a Carrier is detected.

- **Preamble Detection**

The Carrier/Preamble detection Block notifies to the host controller the presence of a Carrier modulated at the Programmed Baud Rate for at least 4 Consecutive Symbols (“1010” or “0101” are the symbols sequences detected).

CD_PD line is forced low till a Carrier signal is detected and PLL is in the lock-in range.

To reinforce the effectiveness of the information given by CD_PD Block, a digital filtering is applied on Carrier or Preamble notification signal (see [Section 6.8: Control register](#)). The Detection Time Bits in the Control Register define the filter performance. Increasing the Detection Time reduced the false notifications caused by noise on main line. The Digital filter adds a delay to CD_PD notification equal to the programmed Detection Time. When the carrier frequency disappears, CD_PD line is held low for a period equal to the detection time and then forced high. During this time, some spurious data caused by noise can be demodulated and sent over RxD line.

- **Header Recognition**

In Control Register Extended Mode (Control Register bit 21="1", see [Table 12](#)) the CD_PD line can be used to recognize if an header has been sent during the transmission. With Header Recognition function enable (Control Register bit 18="1", see [Table 12](#)), CD_PD line is forced low when a Frame Header is detected. If Frame Length Count function is enabled, CD_PD is held low and a number of 16 bit word equal to the Frame Length selected is sent to the host controller. In this case, CLR/T is forced to "0" and RxD is forced to "0" or "1" (according the UART/SPI pin level) when Header has not been detected or after the Frame Length has been reached.

If Frame Length Count function is disabled, an header recognition is signaled by forcing CD_PD low for one period of CLR/T line. In this case, CLR/T and RxD signal are always present, even if no header has been recognized.

Figure 14. CD_PD Timing during RX

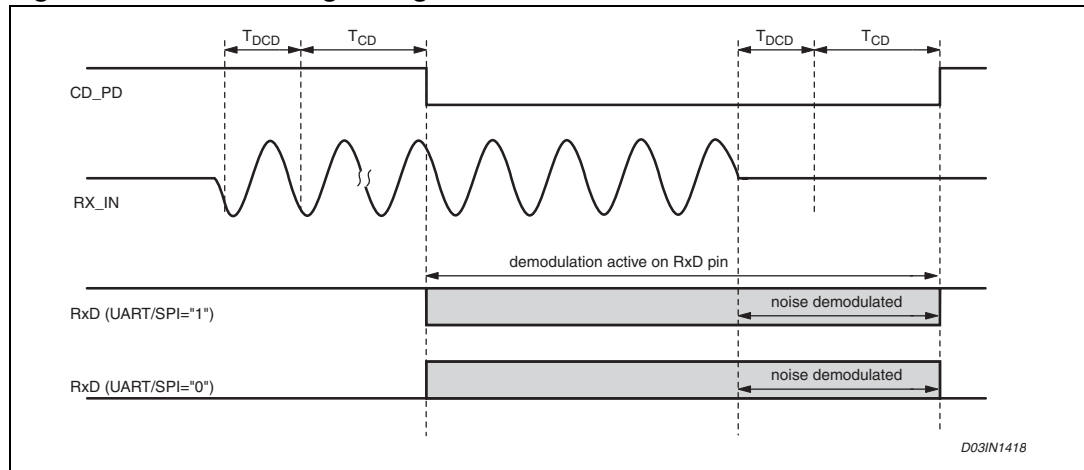
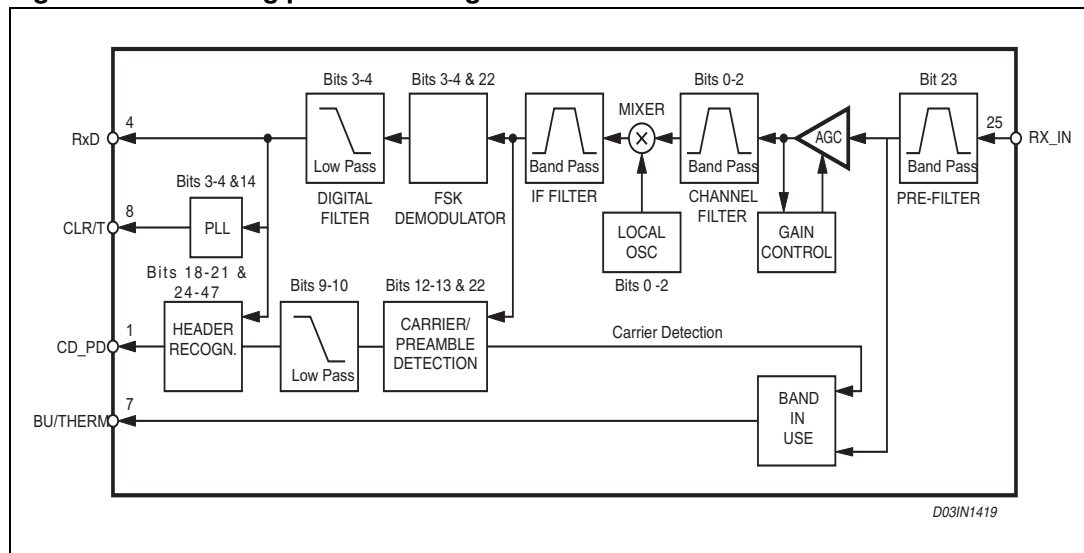

Figure 15. Receiving path block diagram



6.7 Transmission mode

The transmission mode is set when RxD Pin = "0" and REG_DATA Pin = "0". In transmitting mode the FSK Modulator and the Power Line Interface are turned ON. The transmit Data (TxD) enter synchronously or asynchronously to the FSK modulator.

- Synchronous Mains access: on CLR/T rising edge, TxD Line Value is read and sent to the FSK Modulator. ST7540 manages the Transmission timing according to the BaudRate Selected
- Asynchronous Mains access: TxD data enter directly to the FSK Modulator. The Host Controller manages the Transmission timing

In both conditions no Protocol Bits are added by ST7540.

The FSK frequencies are synthesized in the FSK modulator from a 16 MHz crystal oscillator by direct digital synthesis technique. The frequencies Table in different Configuration is reported in [Table 8](#). The frequencies precision is same as external crystal one's.

In the analog domain, the signal is filtered in order to reduce the output signal spectrum and to reduce the harmonic distortion. The transition between a symbol and the following is done at the end of the on-going half FSK sinewave cycle.

Figure 16. Transmitting path block diagram

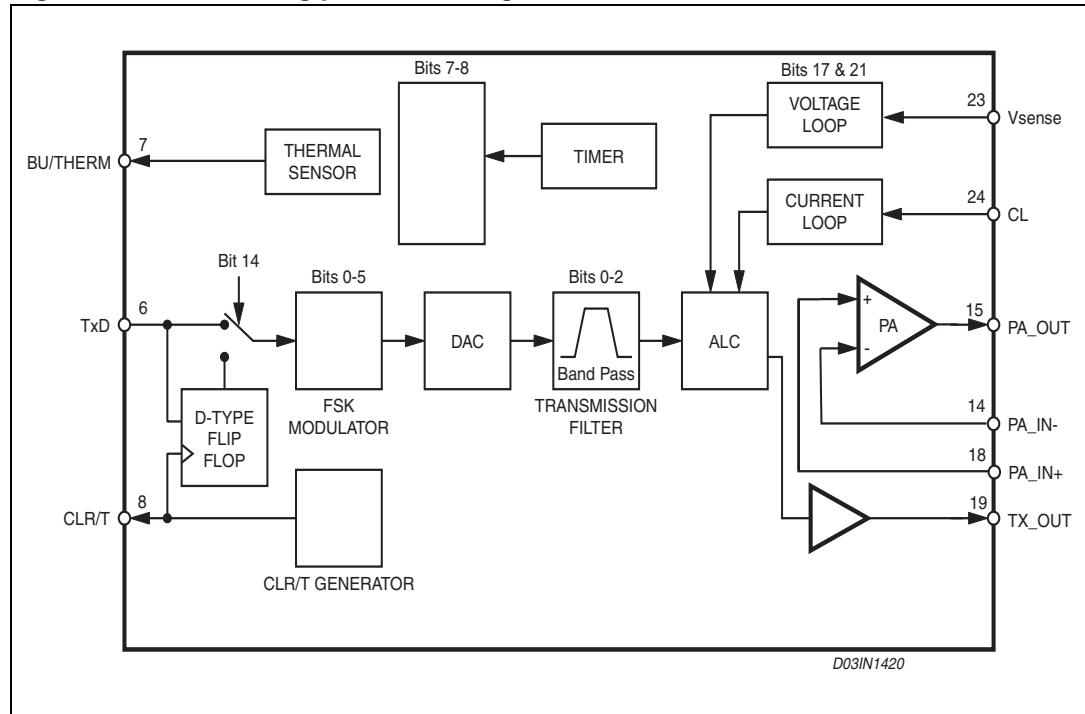

- **Automatic Level Control (ALC)**

The Automatic Level Control Block (ALC) is a variable gain amplifier (with 32 non linear discrete steps) controlled by two analog feed backs acting at the same time. The ALC gain range is 0dB to 30 dB and the gain change is clocked at 5KHz. Each step increases or reduces the voltage of 1dB (Typ).

Two are the control loops acting to define the ALC gain:

- A Voltage Control loop
- A Current Control Loop

The Voltage control loop acts to keep the Peak-to-Peak Voltage constant on Vsense. The gain adjustment is related to the result of a peak detection between the Voltage waveform on Vsense and two internal Voltage references. It is possible to protect the Voltage Control Loop against noise by freezing the output level (see [Section 7.5: Output voltage level freeze](#)).

- If $V_{sense} < V_{sense_{TH}} - V_{sense_{HYST}}$ The next gain level is increased by 1 step
- If $V_{sense_{TH}} - V_{sense_{HYST}} < V_{sense} < V_{sense_{TH}} + V_{sense_{HYST}}$ No Gain Change
- If $V_{sense} > V_{sense_{TH}} + V_{sense_{HYST}}$ The next gain level is decreased by 1 step

The Current control loop acts to limit the maximum Peak Output current inside PA_OUT.

The current control loop acts through the voltage control loop decreasing the Output Peak-to-Peak Amplitude to reduce the Current inside the Power Line Interface.

The current sensing is done by mirroring the current in the High side MOS of the Power Amplifier (not dissipating current Sensing). The Output Current Limit (up to 500mrms), is set by means of an external resistor (R_{CL}) connected between CL and V_{SS}. The resistor converts the current sensed into a voltage signal. The Peak current sensing block works as the Output Voltage sensing Block:

- If V(CL) < CL_{TH} - CL_{HYST} Voltage Control Loop Acting
- If CL_{TH} - CL_{HYST} < V(CL) < CL_{TH} + CL_{HYST} No Gain Change
- If V(CL) > CL_{TH} + CL_{HYST} The next gain level is decreased by 1 step

Figure 17 shows the typical connection of Current and Voltage control loops.

Figure 17. Voltage and current feedback external interconnection example

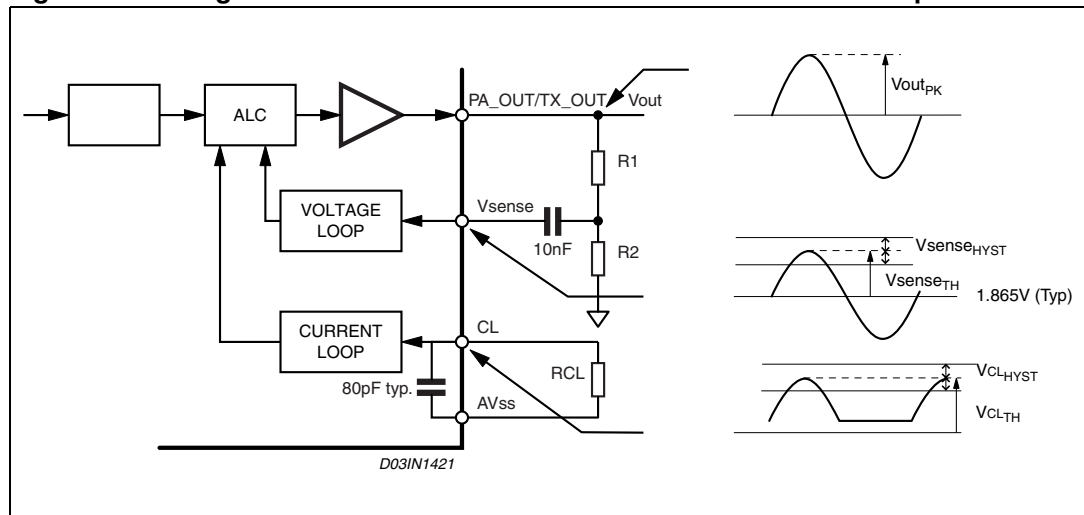

Voltage Control Loop Formula

$$V_{OUTPK} \cong \frac{R_1 + R_2}{R_2} \cdot (V_{SENSE_TH} \pm V_{SENSE_HYST})$$

Table 11. V_{OUT} Vs. R1 & R2 resistors value

Vout (Vrms)	Vout (dBμV)	(R1+R2)/R2	R2 (KΩ)	R1 (KΩ)
0.150	103.5	1.1	7.5	1.0
0.250	108.0	1.9	5.1	3.9
0.350	110.9	2.7	3.6	5.6
0.500	114.0	3.7	3.3	8.2
0.625	115.9	4.7	3.3	11.0
0.750	117.5	5.8	2.7	12.0
0.875	118.8	6.6	2.0	11.0
1.000	120.0	7.6	1.6	10.0
1.250	121.9	9.5	1.6	13.0
1.500	123.5	10.8	1.6	15.0

Note: Notes: The rate of R2 takes in account the input resistance on the V_{SENSE} pin (36KΩ). 10nF capacitor effect has been neglected.

Figure 18. Typical output current vs RCL

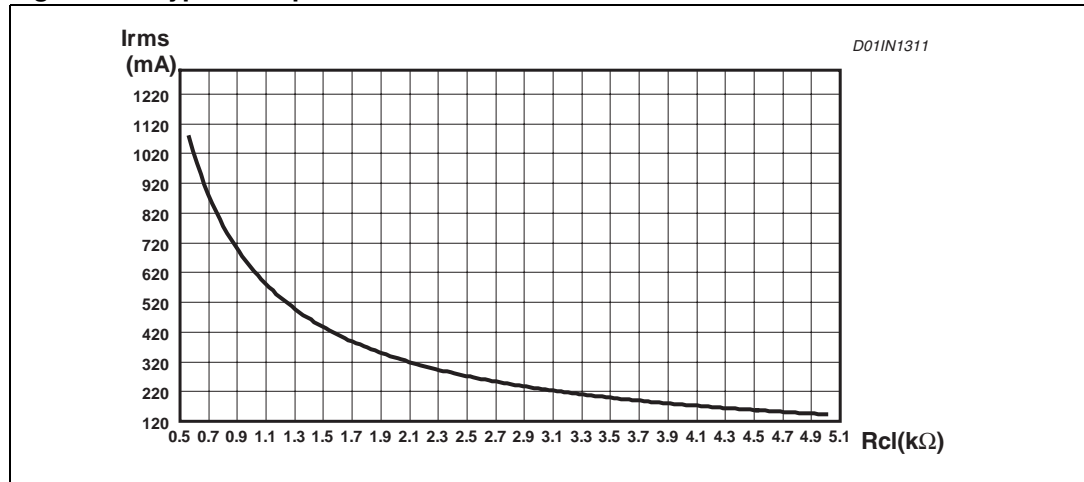

● **Integrated Power Line Interface (PLI)**

The Power Amplifier (PA) is a CMOS AB Class Power Amplifier. The PA requires, to ensure a proper

operation, a regulated and well filtered Supply Voltage. V_{CC} Voltage and PA_OUT Voltage must fulfil

the following formulas to work without clipping phenomena:

$$V_{CC} \geq \frac{V_{PAOUT(AC)}}{2} + V_{POUT(DC)} + 3V$$

$$V_{POUT(DC)} - \frac{V_{PAOUT(AC)}}{2} \geq 1.5V$$

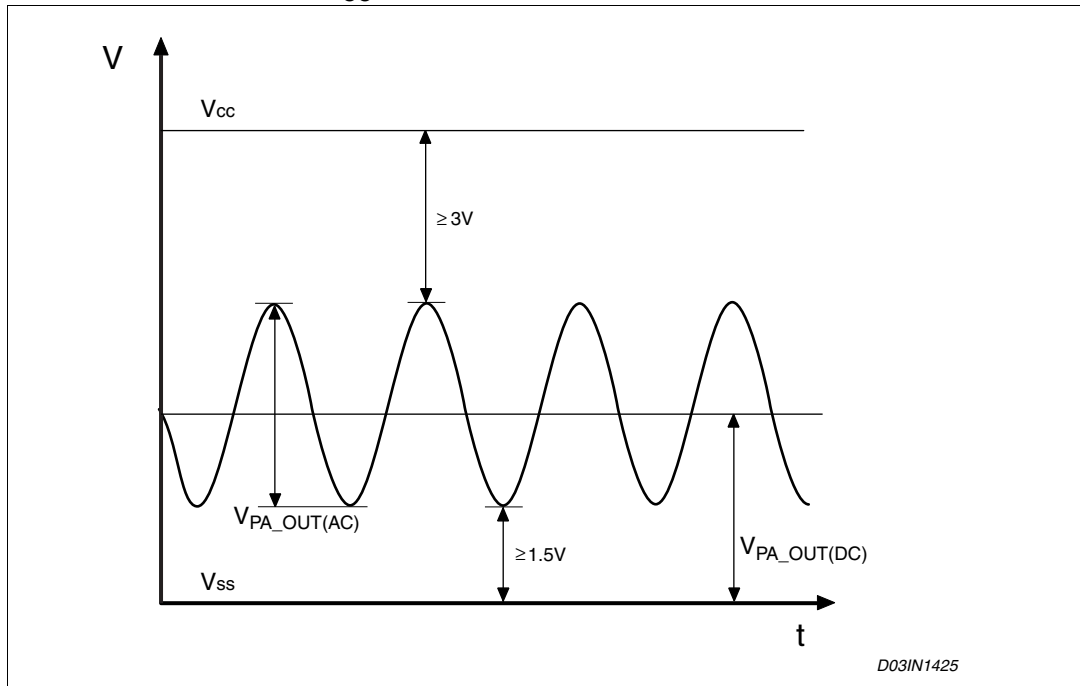
Figure 19. PA_OUT and V_{CC} relationship

Inputs and outputs of PA are available on pins PA_IN-, PA_IN+ and PA_OUT. User can easily select an appropriate active filtering topology to filter the signal present on TX_OUT pin. TX_OUT output has a current capability much lower than PA_OUT.

Figure 20. Power line interface topology

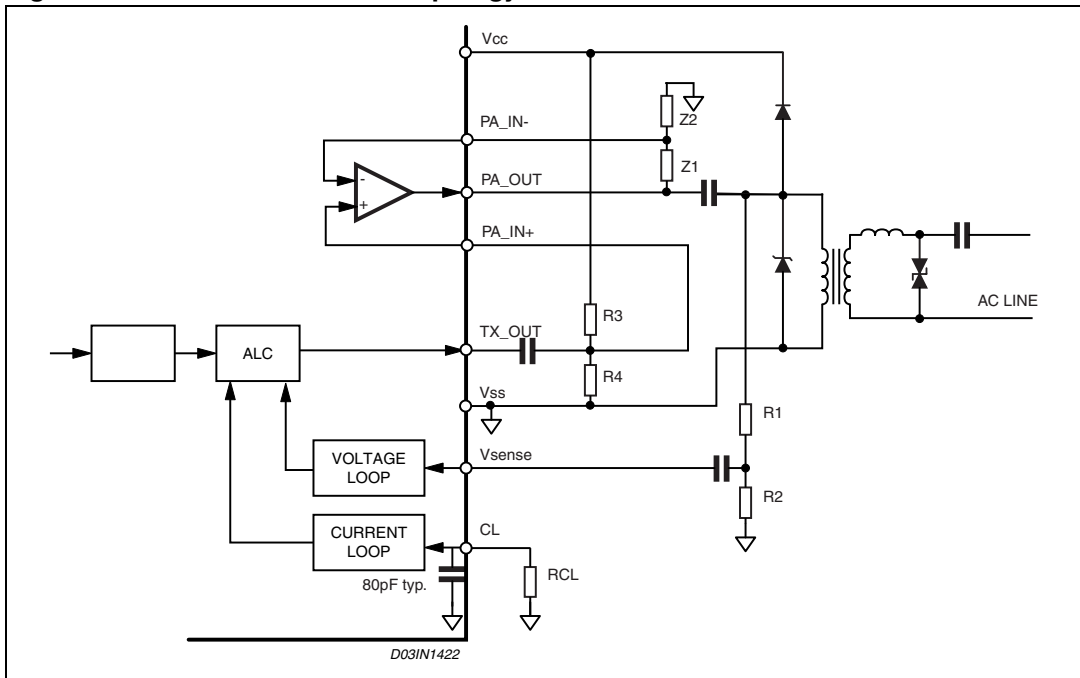
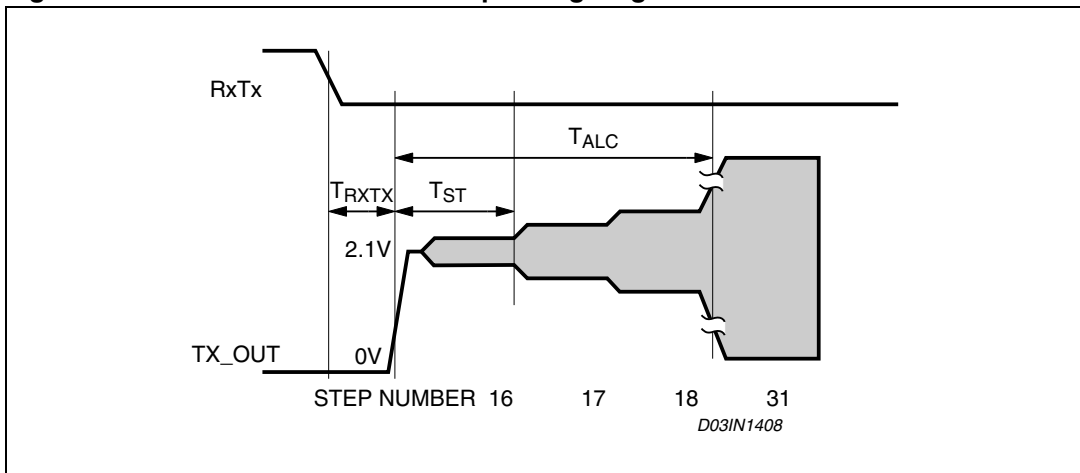

Figure 21. Power line interface startup timing diagram



6.8 Control register

The ST7540 is a multi-channel and multifunction transceiver. An internal 24 or 48 Bits (in Extended mode) Control Register allows to manage all the programmable parameters ([Table 12](#)).

The programmable functions are:

- Channel Frequency
- Baud Rate
- Deviation
- Watchdog
- Transmission Timeout
- Frequency Detection Time
- Detection Method
- Mains Interfacing Mode
- Output Clock
- Sensitivity Mode
- Input Pre-Filter

In addition to these functions the Extended mode provides 24 additional bits and others functions:

- Output Level Freeze
- Frame Header Recognizes (one 16 bits header of or two 8 bits headers) with support to Frame Length Bit count

Table 12. Control register functions

	Function	Value	Selection			Note	Default
0 to 2	Frequencies	60 KHz	0	0	0		132.5 kHz
		66 KHz	0	0	1		
		72 KHz	0	1	0		
		76 KHz	0	1	1		
		82.05 KHz	1	0	0		
		86 KHz	1	0	1		
		110 KHz	1	1	0		
132.5 KHz	1	1	1				
3 to 4	Baud rate	600	Bit 4		Bit 3		2400
		1,200	0	0			
		2,400	0	1			
		4,800	1	0			
5	Deviation	0.5	Bit 5			0.5	
		1	0	1			
6	Watchdog	Disabled	Bit 6			Enabled	
		Enabled (1.5 s)	0	1			
7 to 8	Transmission time out	Disabled	Bit 8	Bit 7		1 sec	
		1 s	0	0			
		3 s	0	1			
		Not Used	1	0			
9 to 10	Frequency detection time	500 μ s	1	1		1 ms	
		1 ms	0	0			
		3 ms	0	1			
		5 ms	1	0			
11	Reserved					Do not force a different value	0

Table 12. Control register functions

	Function	Value	Selection		Note	Default
			Bit 13	Bit 12		
12 to 13	Detection method	Preamble detection without conditioning	0	0	Preamble detection notification on CD_PD Line CLR/T and RxD signal always present In UART Mode (UART/SPI pin set to 1) this configuration is not allowed.	Carrier detection without conditioning
		Preamble detection with conditioning	0	1	Preamble Detection notification on CD_PD Line. CLR/T and RxD line are forced to "0" when Preamble has not been detected or PLL is in Unlock condition. In UART Mode (UART/SPI pin set to 1) this configuration is not allowed.	
		Carrier detection without conditioning	1	0	Carrier detection notification on CD_PD Line CLR/T and RxD signal always present	
		Carrier detection with conditioning	1	1	Carrier detection notification on CD_PD Line CLR/T Line is forced to "0" and RxD Line is forced to "0" or "1" (according the UART/SPI pin level) when carrier is not detected	
14	Mains Interfacing Mode	Synchronous Asynchronous	Bit 14			Asynchronous
			0 1			
15 to 16	Output Clock	16 MHz 8 MHz 4 MHz Clock OFF	Bit 16	Bit 15		4 MHz
			0	0		
			0	1		
			1	0		
17	Output Voltage Level Freeze	Enabled Disabled	Bit 17		Active only if extended control register is enable (Bit 21="1")	Disabled
			0 1			
18	Header Recognition	Disabled Enabled	Bit 18		Active only if extended control register is enable (Bit 21="1")	Disabled
			0 1			
19	Frame Length Count	Disabled Enabled	Bit 19		Active only if header recognition function (Bit 18="1") and extended control register (Bit 21="1") are enable	Disabled
			0 1			

Table 12. Control register functions

	Function	Value	Selection	Note	Default
20	Header Length	8 bits 16 bits	Bit 20	Active only if Extended Control Register is enable (Bit 21="1")	16 bits
			0 1		
21	Extended Register	Disable (24 bits) Enabled (48 bits)	Bit 21	Extended Register enables Functions on Bit 17, 18,19 and 20	Disabled (24 bits)
			0 1		
22	Sensitivity Mode	Normal Sensitivity High Sensitivity	Bit 22		Normal
			0 1		
23	Input Filter	Disabled Enabled	Bit 23		Disabled
			0 1		
24 to 39	Frame Header	from 0000h to FFFFh		One 16 bits Header or two 8 bits Headers (MSB first) depending on Bit 20	9B58h
40 to 47	Frame Length	from 01h to FFh		Number of 16 bits words expected	08h

7 Auxiliary analog and digital functions

7.1 Band in use

The Band in Use Block has a Carrier Detection like function but with a different Input Sensitivity (83.5 dB μ V Typ.) and with a different BandPass filter Selectivity (40dB/Dec).

BU/THERM line is forced High when a signal in band is detected.

To prevent BU/THERM line false transition, Band in Use signal is conditioned to Carrier Detection Internal Signal. This function is enabled only in Receiving mode (in Transmission mode the BU/THERM pin is used for Thermal shutdown signaling, see [Section 7.8: Thermal shutdown](#)).

7.2 Time out

Time Out Function is a protection against a too long data transmission. When Time Out function is enabled after 1 or 3 second of continuous transmission the transceiver is forced in receiving mode. This function allows ST7540 to automatically manage the CENELEC Medium Access specification. When a time-out event occur, the transmission section is disabled for at least 125 ms. To Unlock the Time Out condition RxTx should be forced High. During the time out period only register access or reception mode are enabled.

During Reset sequence if RxTx line = "0" & REG_DATA line = "0", Time Out protection is suddenly enabled and ST7540 must be configured in data reception after the reset event before starting a new data transmission.

Time Out time is programmable using Control Register bits 7 and 8 ([Table 12](#)).

Figure 22. Time-out timing and unlock sequence

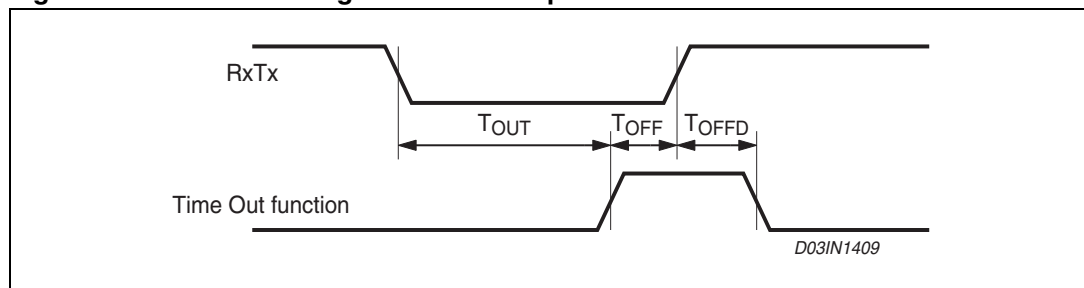

7.3 Reset & watchdog

RSTO Output is a reset generator for the application circuitry. During the ST7540 startup sequence is forced low. RSTO becomes high after a T_{RSTO} delay from the end of oscillator startup sequence.

Inside ST7540 is also embedded a watchdog function. The watchdog function is used to detect the occurrence of a software fault of the Host Controller. The watchdog circuitry generates an internal and external reset (RSTO low for T_{RSTO} time) on expiry of the internal watchdog timer. The watchdog timer reset can be achieved applying a negative pulse on WD pin (see [Figure 23](#)).

Figure 23. Reset and Watchdog Timing

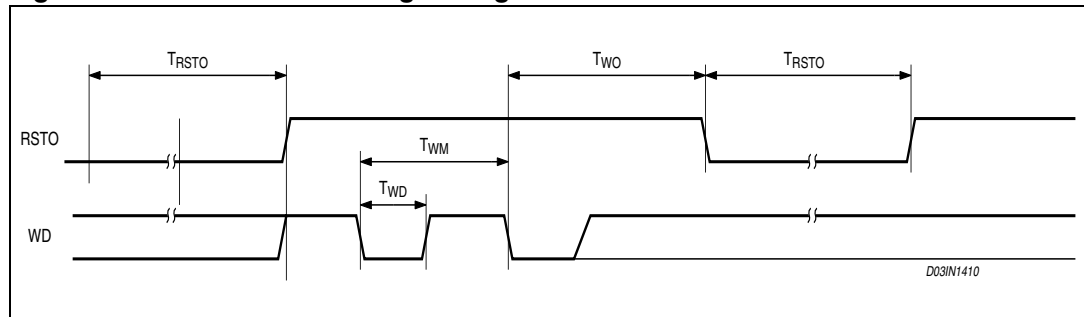

7.4 Output clock

MCLK is the master clock output. The clock frequency sourced can be programmed through the Control Register to be a ratio of the crystal oscillator frequency (F_{osc} , $F_{osc}/2$, $F_{osc}/4$). The transition between one frequency and another is done only at the end of the ongoing cycle. The oscillator can be disabled using Control Register bits 15 and 16 ([Table 12](#)).

7.5 Output voltage level freeze

The Output Level Freeze function, when enabled, turns off the Voltage Control Loop once the ALC stays in a stable condition for about 3 periods of control loop, and maintains a constant gain until the end of transmission. Output Level Freeze can be enabled using Control Register bit 17 ([Table 12](#)). This function is available only using the Extended Control Register (Control Register bit 21="1").

7.6 Extended control register

When Extended Control Register function is enabled, all the 48 bits of Control Register are programmable. Otherwise, only the first 24 bits of Control Register are programmable. The functions Header Recognition, Frame Bit Count and Output Voltage Freeze are available only if Extended Control Register function is enabled. Extended Control Register can be enabled using Control Register bit 21 ([Table 12](#)).

7.7 Under voltage lock out

The UVLO function turns off the device if the V_{CC} voltage falls under 4V. Hysteresis is 340mV typically.

7.8 Thermal shutdown

The ST7540 is provided of a thermal protection which turn off the PLI when the junction temperature exceeds $170^{\circ}\text{C} \pm 10\%$. Hysteresis is around 30°C .

When shutdown threshold is overcome, PLI interface is switched OFF.

Thermal Shutdown event is notified to the HOST controller using BU/THERM line. When BU/THERM line is High, ST7540 junction temperature exceed the shutdown threshold (Not Latched). This function is enabled only in Transmission mode (in Receiving mode the BU/THERM pin is used for Band in Use signaling, see Band in Use function [Section 7.1: Band in use](#)).

7.9 5V Voltage regulator

ST7540 has an embedded 5V linear regulator externally available (on pin VDC) to supply the application circuitry. The 5V linear regulator has a very low quiescent current ($50\mu\text{A}$) and a current capability of 50mA. The regulator is protected against short circuitry events.

7.10 3.3V Voltage regulator

The V_{DD} pin can act either as 3.3V Voltage Output or as Input Digital Supply. When the V_{DD} pin is externally forced to 5V all the Digital I/Os operate at 5V, otherwise all the Digital I/Os are internally supplied at 3.3V. The V_{DD} pin can also source 3.3V voltage to supply external components. The 3.3V linear regulator has a very low quiescent current ($50\mu\text{A}$) and a current capability of 50mA. The regulator is protected against short circuitry events.

7.11 Power-up procedure

To ensure ST7540 proper power-Up sequence, V_{CC} and V_{DD} Supply has to fulfil the following rules:

1. V_{CC} rising slope must not exceed 100V/ms.
2. When V_{DD} is below 5V/3.3V: $V_{CC}-V_{DD} < 1.2\text{V}$.

When V_{DD} supply is connected to VDC (5V Digital Supply) the above mentioned relation can be ignored if VDC load $< 50\text{mA}$ and if the filtering capacitor on VDC $< 100\mu\text{F}$.

If V_{DD} is not forced to 5V, the Digital I/Os are internally supplied at 3.3 V and if V_{DD} load $< 50\text{mA}$ and the filtering capacitor on V_{DD} $< 100\mu\text{F}$ the second relation can be ignored.

Figure 24. Power-up sequence

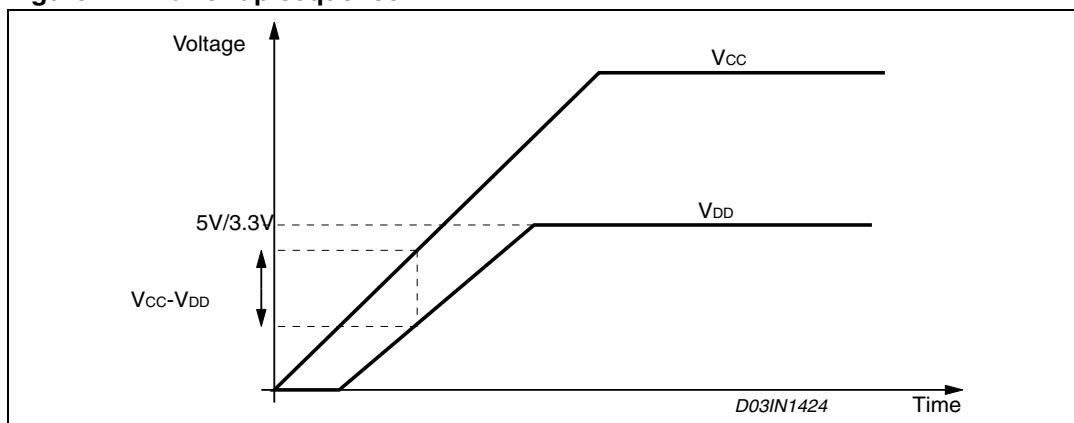
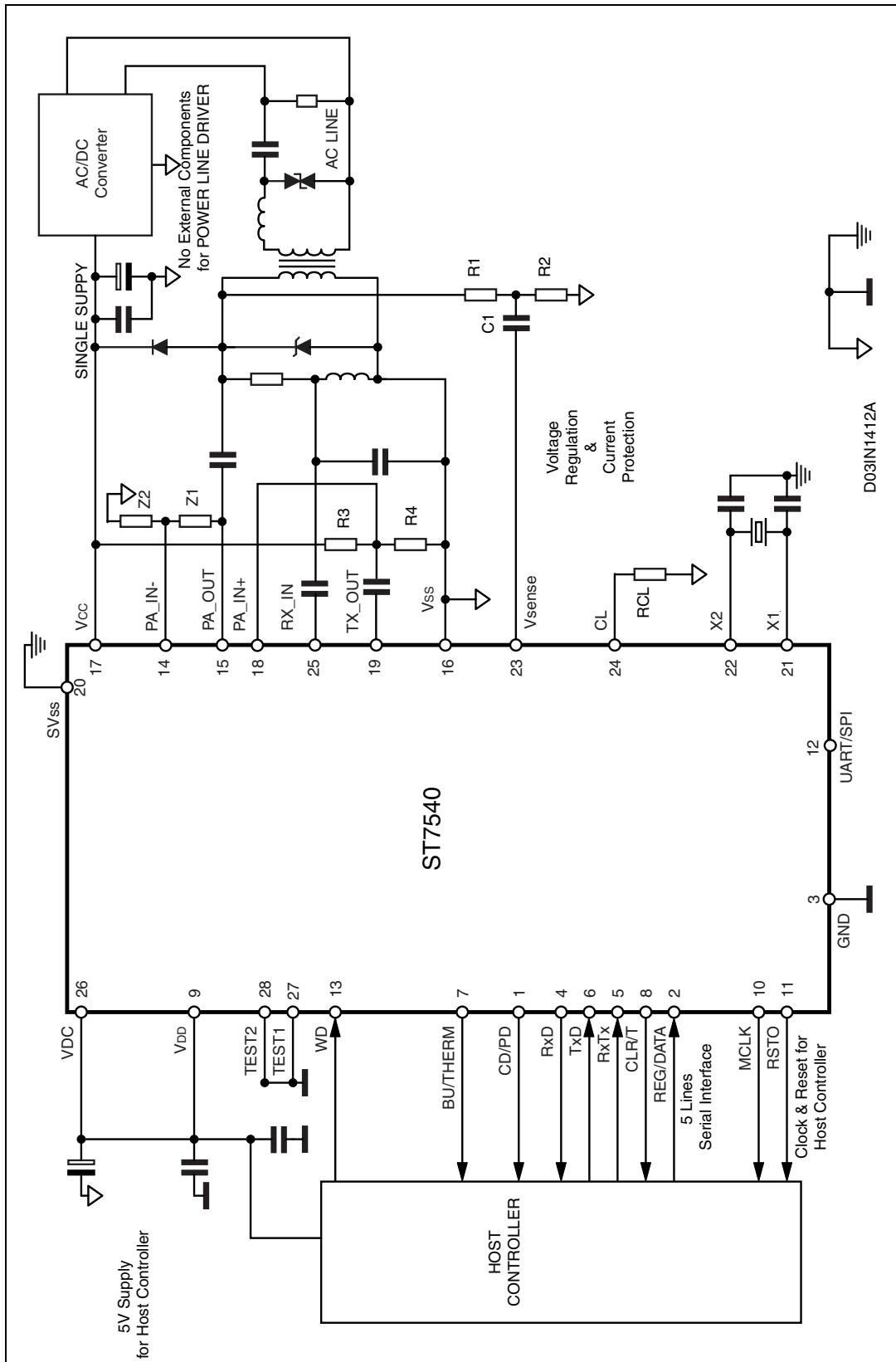

Figure 25. Application schematic example with coupling transformer.



8 Mechanical data

In order to meet environmental requirements, ST offers these devices in ECOPACK® packages. These packages have a Lead-free second level interconnect . The category of second level interconnect is marked on the package and on the inner box label, in compliance with JEDEC Standard JESD97. The maximum ratings related to soldering conditions are also marked on the inner box label. ECOPACK is an ST trademark. ECOPACK specifications are available at: www.st.com

Table 13. HTSSOP28 Mechanical data

Dim.	mm.			inch		
	Min.	Typ.	Max.	Min.	Typ.	Max.
A			1.2			0.047
A1			0.15			0.006
A2	0.8	1.0	1.05	0.031	0.039	0.041
b	0.19		0.3	0.007		0.012
c	0.09		0.2	0.003		0.008
D (*)	9.6	9.7	9.8	0.377	0.382	0.385
D1	3.3			0.130		
E	6.2	6.4	6.6	0.244	0.252	0.260
E1 (*)	4.3	4.4	4.5	0.169	0.173	0.177
E2	1.5					
e		0.65			0.026	
L	0.45	0.6	0.75	0.018	0.024	0.029
L1		1.0			0.039	
k	0° (min), 8° (max)					
aaa		0.1			0.004	

Figure 26. Package dimensions

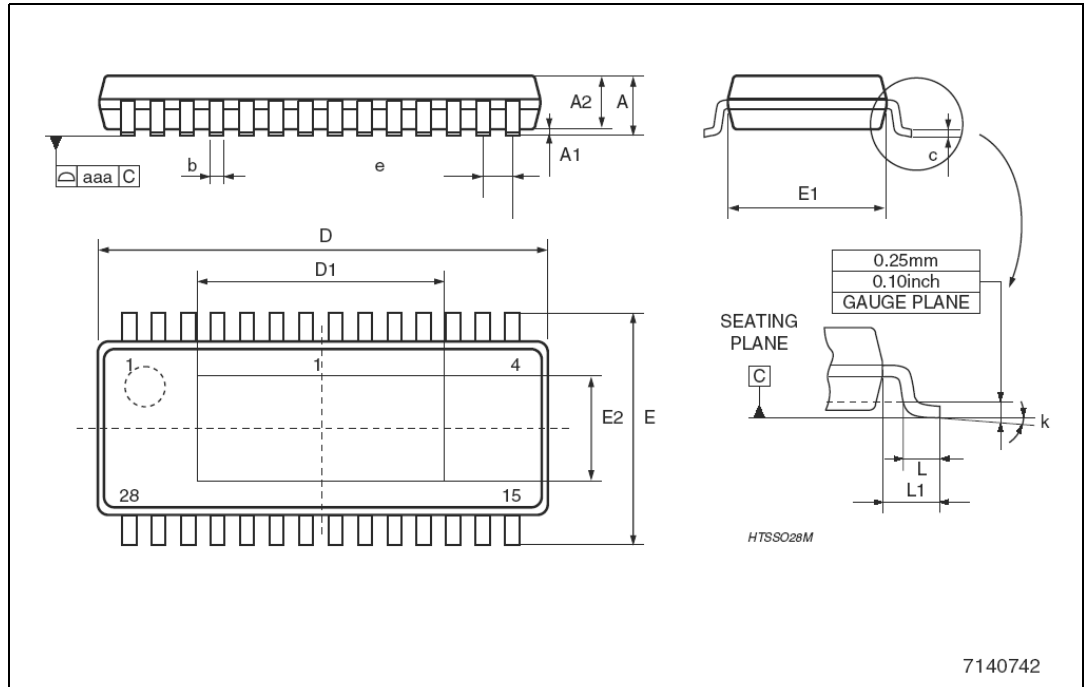

9 Revision history

Table 14. Revision history

Date	Revision	Changes
15-Mar-2006	1	Initial release.
25-Sep-2006	2	Updated Electrical Characteristics and Power Amplifier description

Please Read Carefully:

Information in this document is provided solely in connection with ST products. STMicroelectronics NV and its subsidiaries ("ST") reserve the right to make changes, corrections, modifications or improvements, to this document, and the products and services described herein at any time, without notice.

All ST products are sold pursuant to ST's terms and conditions of sale.

Purchasers are solely responsible for the choice, selection and use of the ST products and services described herein, and ST assumes no liability whatsoever relating to the choice, selection or use of the ST products and services described herein.

No license, express or implied, by estoppel or otherwise, to any intellectual property rights is granted under this document. If any part of this document refers to any third party products or services it shall not be deemed a license grant by ST for the use of such third party products or services, or any intellectual property contained therein or considered as a warranty covering the use in any manner whatsoever of such third party products or services or any intellectual property contained therein.

UNLESS OTHERWISE SET FORTH IN ST'S TERMS AND CONDITIONS OF SALE ST DISCLAIMS ANY EXPRESS OR IMPLIED WARRANTY WITH RESPECT TO THE USE AND/OR SALE OF ST PRODUCTS INCLUDING WITHOUT LIMITATION IMPLIED WARRANTIES OF MERCHANTABILITY, FITNESS FOR A PARTICULAR PURPOSE (AND THEIR EQUIVALENTS UNDER THE LAWS OF ANY JURISDICTION), OR INFRINGEMENT OF ANY PATENT, COPYRIGHT OR OTHER INTELLECTUAL PROPERTY RIGHT.

UNLESS EXPRESSLY APPROVED IN WRITING BY AN AUTHORIZED ST REPRESENTATIVE, ST PRODUCTS ARE NOT RECOMMENDED, AUTHORIZED OR WARRANTED FOR USE IN MILITARY, AIR CRAFT, SPACE, LIFE SAVING, OR LIFE SUSTAINING APPLICATIONS, NOR IN PRODUCTS OR SYSTEMS WHERE FAILURE OR MALFUNCTION MAY RESULT IN PERSONAL INJURY, DEATH, OR SEVERE PROPERTY OR ENVIRONMENTAL DAMAGE. ST PRODUCTS WHICH ARE NOT SPECIFIED AS "AUTOMOTIVE GRADE" MAY ONLY BE USED IN AUTOMOTIVE APPLICATIONS AT USER'S OWN RISK.

Resale of ST products with provisions different from the statements and/or technical features set forth in this document shall immediately void any warranty granted by ST for the ST product or service described herein and shall not create or extend in any manner whatsoever, any liability of ST.

ST and the ST logo are trademarks or registered trademarks of ST in various countries.

Information in this document supersedes and replaces all information previously supplied.

The ST logo is a registered trademark of STMicroelectronics. All other names are the property of their respective owners.

© 2006 STMicroelectronics - All rights reserved

STMicroelectronics group of companies

Australia - Belgium - Brazil - Canada - China - Czech Republic - Finland - France - Germany - Hong Kong - India - Israel - Italy - Japan - Malaysia - Malta - Morocco - Singapore - Spain - Sweden - Switzerland - United Kingdom - United States of America

www.st.com