



LOW POWER HIGH SPEED RS-485/RS-422 TRANSCEIVER

- LOW SUPPLY CURRENT: 5mA MAX
- -7 TO 12 COMMON MODE INPUT VOLTAGE RANGE
- 70mV TYPICAL INPUT HYSTERESIS
- DESIGNED FOR 25Mbps OPERATION
- OPERATE FROM SINGLE 5 SUPPLY
- ± 4 kV ESD PROTECTION
- CURRENT LIMITING AND THERMAL SHUTDOWN FOR DRIVER OVERLOAD PROTECTION

DESCRIPTION

The ST490A is a low power transceiver for RS-485 and RS-422 communications. The device contains one driver and one receiver in full duplex configuration. The ST490A draws 5mA (typ.) of supply current when unloaded or fully loaded with disabled drivers. It operates from a single 5V supply.

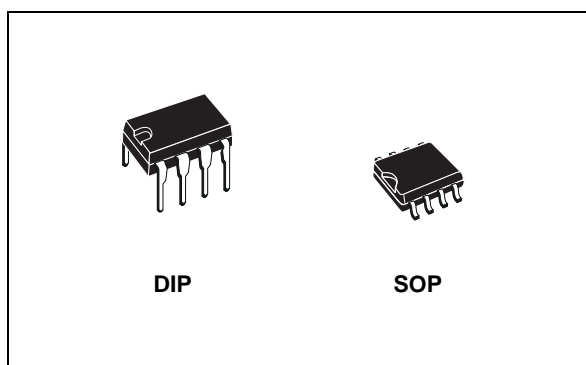

Driver is short-circuit current limited and is protected against excessive power dissipation by thermal shutdown circuitry that place the driver outputs into a high-impedance state. The receiver input has a fail-safe feature that guarantees a logic high output if both inputs are open circuit.

ORDERING CODES

Type	Temperature Range	Package	Comments
ST490ACN	0 to 70 °C	DIP-8	50parts per tube / 40tube per box
ST490ABN	-40 to 85 °C	DIP-8	50parts per tube / 40tube per box
ST490ACD	0 to 70 °C	SO-8 (Tube)	100parts per tube / 20tube per box
ST490ABD	-40 to 85 °C	SO-8 (Tube)	100parts per tube / 20tube per box
ST490ACDR	0 to 70 °C	SO-8 (Tape & Reel)	2500 parts per reel
ST490ABDR	-40 to 85 °C	SO-8 (Tape & Reel)	2500 parts per reel

PIN CONFIGURATION

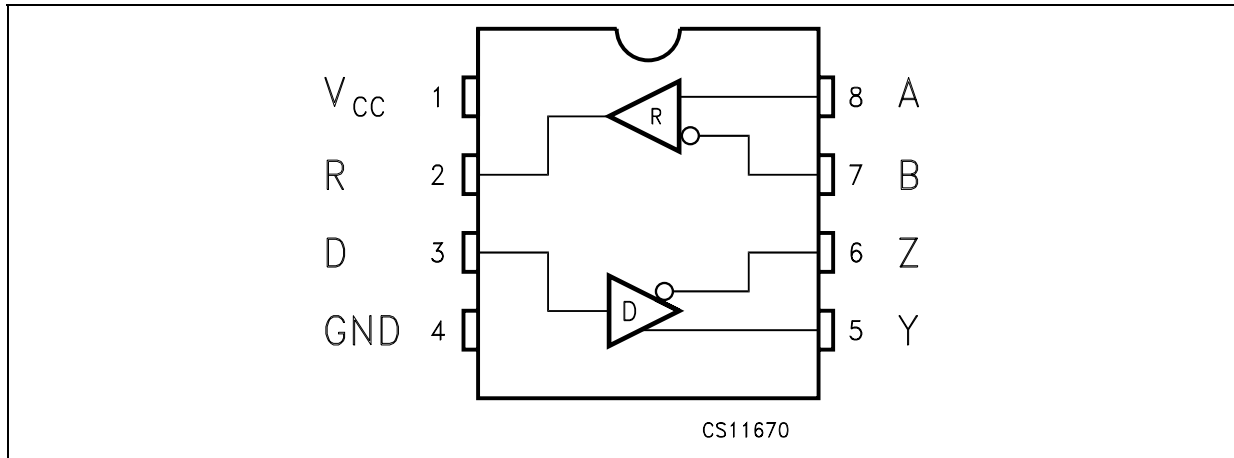

PIN DESCRIPTION

PIN N°	SYMBOL	NAME AND FUNCTION
1	V _{CC}	Supply Voltage
2	RO	Receiver Output.
3	DI	Driver Input.
4	GND	Ground
5	Z	Inverting Driver Output
6	Y	Non-inverting Driver Output
7	B	Inverting Receiver Input
8	A	Non-inverting Receiver Input

TRUTH TABLE (DRIVER)

INPUT	OUTPUTS	
DI	Y	Z
L	L	H
H	H	L

X= Don't Care; Z=High Impedance

TRUTH TABLE (RECEIVER)

DIFFERENTIAL INPUT	OUTPUT
A-B	RO
≥ -0.2V	H
between -0.2V to 0.2V	?
≤ -0.2V	L
OPEN	H

?= Irrelevant; Z=High Impedance

ABSOLUTE MAXIMUM RATINGS

Symbol	Parameter	Value	Unit
V _{CC}	Supply Voltage	7	V
V _{DI}	Driver Input Voltage	-0.5 to 7	V
V _Y , V _Z	Driver Output Voltage	-7.5 to 12.5	V
V _A , V _B	Receiver Input Voltage	-7.5 to 12.5	V
V _{RO}	Receiver Output Voltage	-0.3 to (V _{CC} + 0.3)	V
ESD	Human Body Model	3.5	KV

Absolute Maximum Ratings are those values beyond which damage to the device may occur. Functional operation under these condition is not implied.

ELECTRICAL CHARACTERISTICS

$V_{CC} = 4.5V$ to $5.5V$, $T_A = -40$ to $85^\circ C$, unless otherwise specified. Typical values are referred to $T_A = 25^\circ C$)

Symbol	Parameter	Test Conditions	Min.	Typ.	Max.	Unit
I_{SUPPLY}	No Load Supply Current			2	5	mA
C_{IN}	Input Capacitance			1.8		pF
C_{YZ}	Driver Output Capacitance			1.2		pF
C_{OUT}	Output Capacitance			2.3		pF

TRANSMITTER ELECTRICAL CHARACTERISTICS

$V_{CC} = 4.5V$ to $5.5V$, $T_A = -40$ to $85^\circ C$, unless otherwise specified. Typical values are referred to $T_A = 25^\circ C$)

Symbol	Parameter	Test Conditions	Min.	Typ.	Max.	Unit
V_{OD1}	Differential Drive Output (No load)				V_{CC}	V
V_{OD2}	Differential Drive Output (With Load)	$R_L = 54\Omega$ (RS-422) (Figure 1)	1.5	2.6	5	V
V_{OD3}	Differential Drive Output (With Load)	$R_L = 100\Omega$ (RS-422) (Figure 1)	2	3		V
ΔV_{OD}	Change in magnitude of Driver Differential Output Voltage for Complementary Output States (Note1)	$R_L = 54\Omega$ or 100Ω (Figure 1)		0	0.2	V
V_{OC}	Driver Common Mode Output Voltage	$R_L = 54\Omega$ (Figure 1)	1		3	V
ΔV_{OC}	Change in magnitude of Driver Common Mode Output Voltage (Note1)	$R_L = 54\Omega$ (Figure 1)		0	0.2	V
I_{OFF}	Power Off Output Current	$V_{CC} = 0V$ $V_O = -7V$ to $12V$			± 100	μA
I_{OSD}	Driver Short Circuit Output Current	$V_O = -7V$ to $12V$	± 35		± 250	mA
V_{IL}	Input Logic Threshold Low				0.8	V
V_{IH}	Input Logic Threshold High		2			V

RECEIVER ELECTRICAL CHARACTERISTICS

$V_{CC} = 4.5V$ to $5.5V$, $T_A = -40$ to $85^\circ C$, unless otherwise specified. Typical values are referred to $T_a = 25^\circ C$)

Symbol	Parameter	Test Conditions	Min.	Typ.	Max.	Unit
I_{IN1}	Logic Input Current				± 2.0	μA
I_{IN2}	Input Current (A, B)	other input=0V $V_{CC} = 0$ or $5.25V$	$V_{IN}=12V$	0.5	1	mA
			$V_{IN}=-7V$	-0.35	-0.8	mA
V_{TH}	Receiver Differential Threshold Voltage	$V_{CM} = -7V$ to $12V$	-0.2		0.2	V
ΔV_{TH}	Receiver Input Hysteresis	$V_{CM} = 0V$		70		mV
V_{OH}	Receiver Output High Voltage	$I_{OUT} = -8mA$, $V_{ID} = 200mV$	3.5	4.7		V
V_{OL}	Receiver Output Low Voltage	$I_{OUT} = 8mA$, $V_{ID} = -200mV$		0.2	0.4	V
R_{RIN}	Receiver Input Resistance	$V_{CM} = -7V$ to $12V$	12	24		K Ω
I_{OSR}	Receiver Short-Circuit Current	$V_O = 0V$ to V_{CC}	7		95	mA

DRIVER SWITCHING CHARACTERISTICS

$V_{CC} = 4.5V$ to $5.5V$, $T_A = -40$ to $85^\circ C$, unless otherwise specified. Typical values are referred to $T_a = 25^\circ C$)

Symbol	Parameter	Test Conditions	Min.	Typ.	Max.	Unit
D_R	Maximum Data Rate	Jitter <5%	25	50		Mbps
t_{PLH} t_{PHL}	Propagation Delay Input to Output	$R_L = 54\Omega$ $C_{L1}=C_{L2}=50pF$, (Figure 1)		10	16	ns
t_{SKEW}	Differential Output Delay Skew	$R_L = 54\Omega$ $C_{L1}=C_{L2}=50pF$, (Figure 1)		1	3	ns
t_{TLH} t_{THL}	Rise or Fall Differential Time	$R_L = 54\Omega$ $C_{L1}=C_{L2}=50pF$, (Figure 1)		8	12	ns

RECEIVER SWITCHING CHARACTERISTICS

$V_{CC} = 4.5V$ to $5.5V$, $T_A = -40$ to $85^\circ C$, unless otherwise specified. Typical values are referred to $T_a = 25^\circ C$)

Symbol	Parameter	Test Conditions	Min.	Typ.	Max.	Unit
t_{PLH} t_{PHL}	Propagation Delay Input to Output	$C_L = 15pF$ (Figures 2,4)		19	30	ns
t_{SKD}	$ t_{PLH} - t_{PHL} $ Receiver Output Skew	$C_L = 15pF$ (Figures 2,4)		1	3	ns
t_{TLH} t_{THL}	Rise or Fall Time	$C_L = 15pF$ (Figures 2,4)		8		ns

TEST CIRCUITS AND TYPICAL CHARACTERISTICS

Figure 1 : Driver DC Test Load

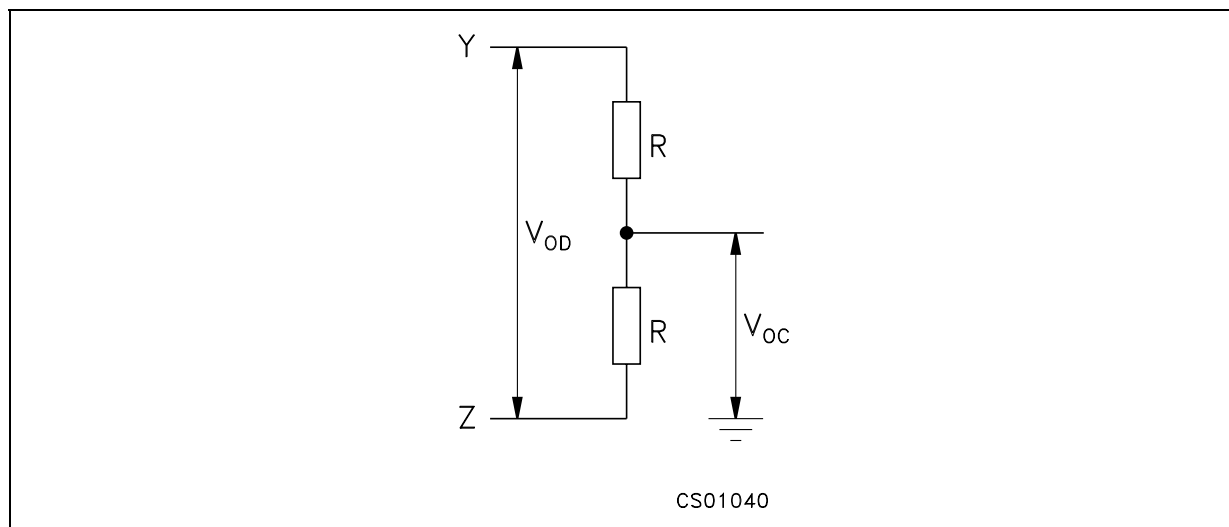

Figure 2 : Driver/Receiver Timing Test Circuit

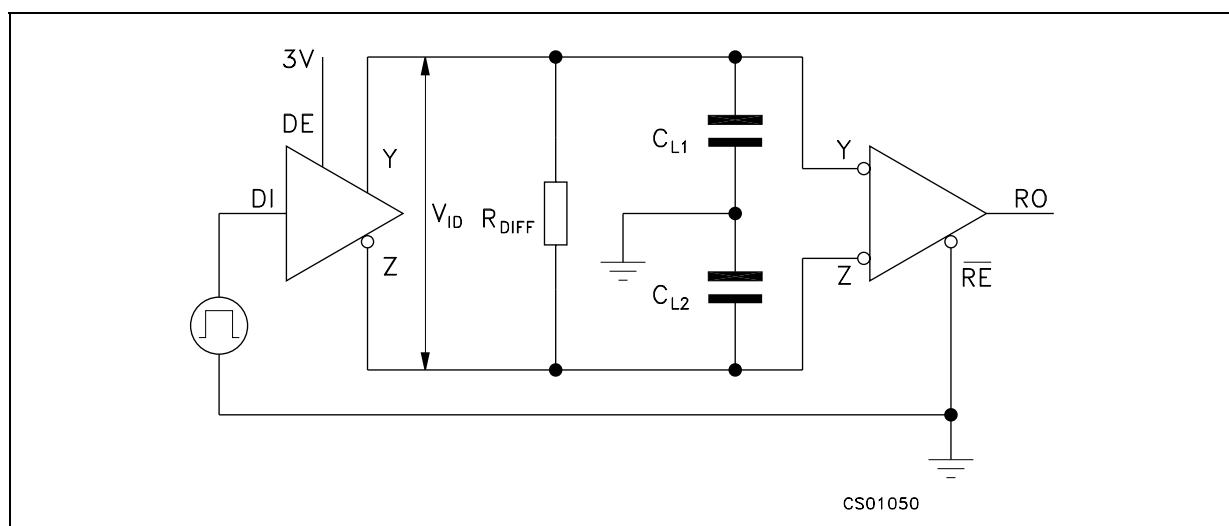

Figure 3 : Driver Propagation Delay

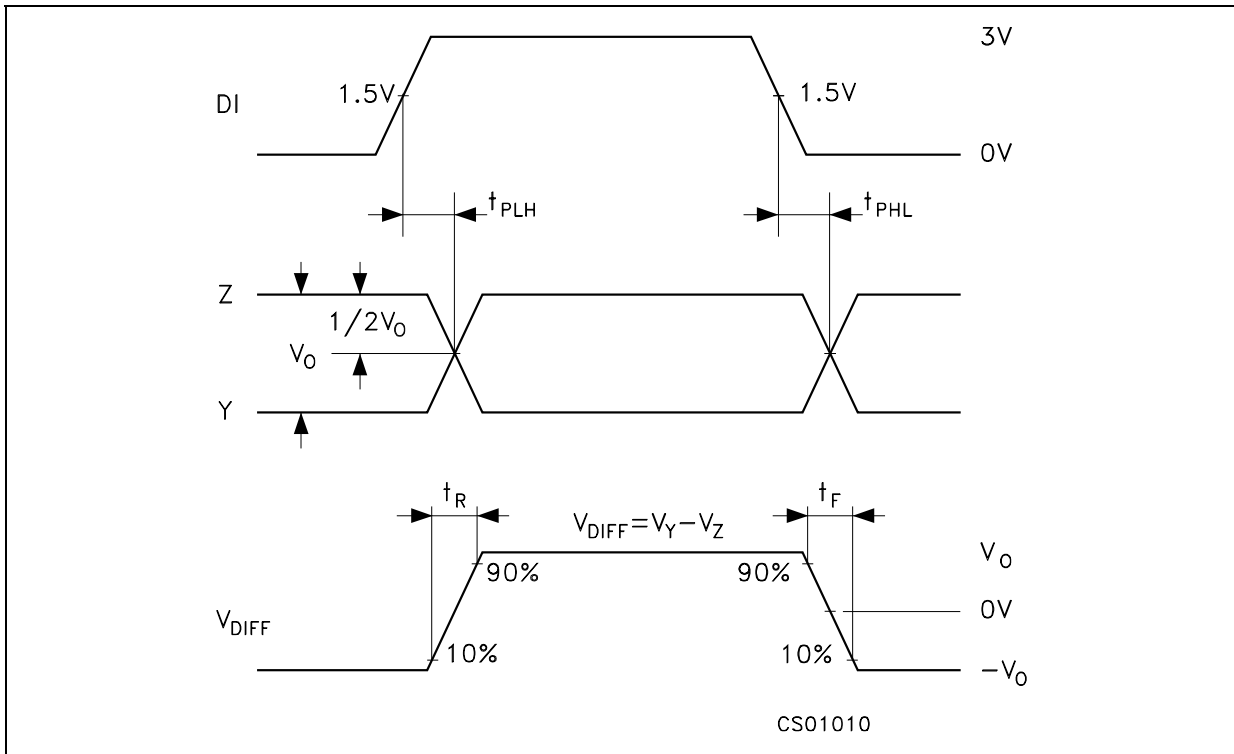

Figure 4 : Receiver Propagation Delay

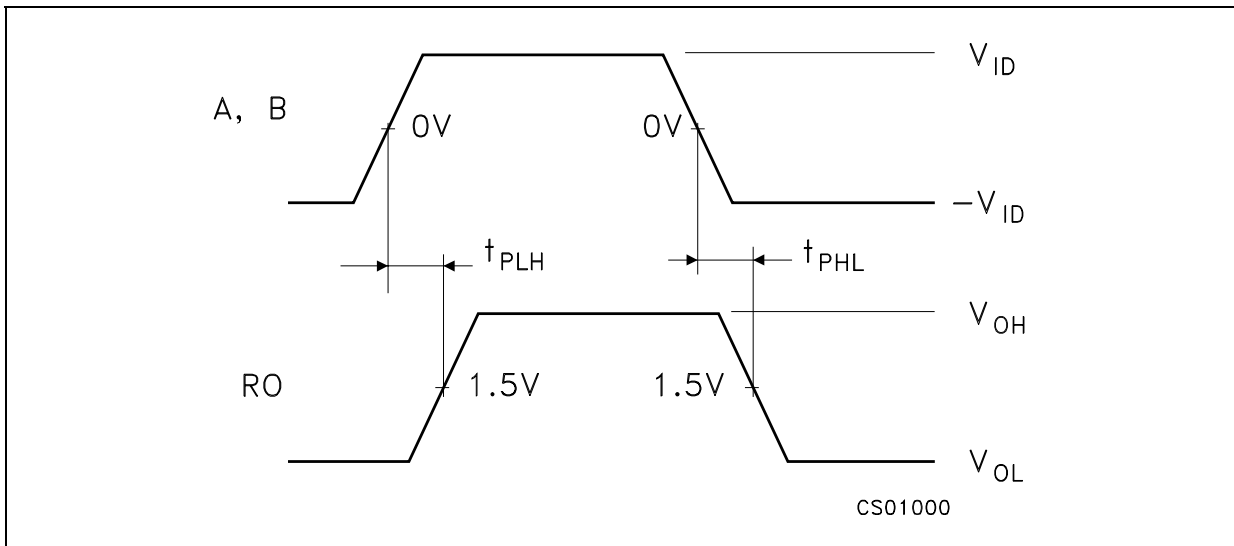

Figure 5 : Receiver Output Current vs Output Voltage (Output Low)

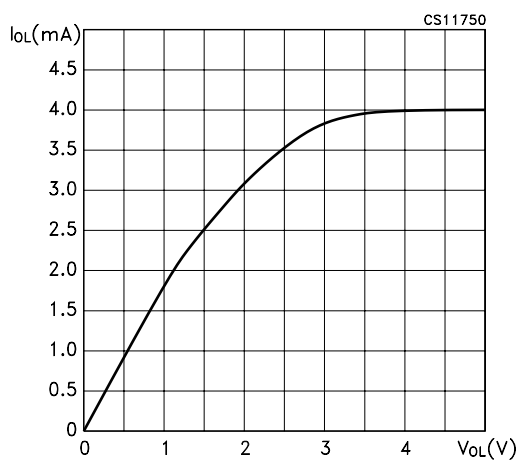

Figure 8 : Driver Diff. Output Voltage vs Common Mode Voltage (Diff. Output High)

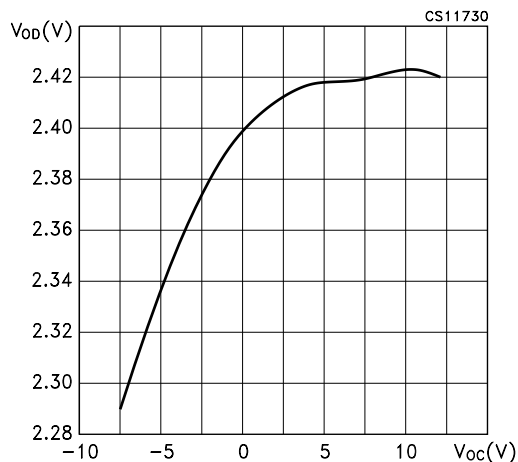

Figure 6 : Receiver Output Current vs Output Voltage (Output High)

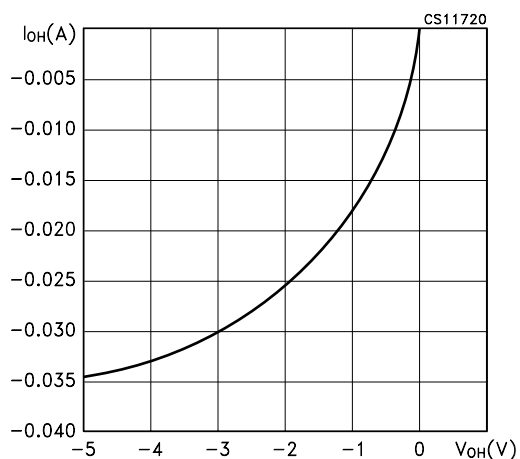

Figure 9 : Driver Short Circuit Current vs Line Voltage (Output High)

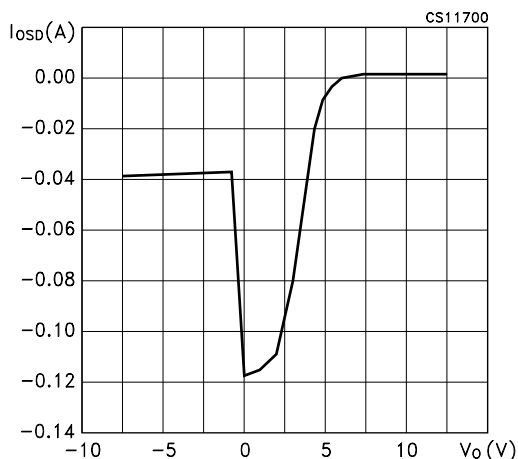

Figure 7 : Driver Diff. Output Voltage vs Common Mode Voltage (Diff. Output Low)

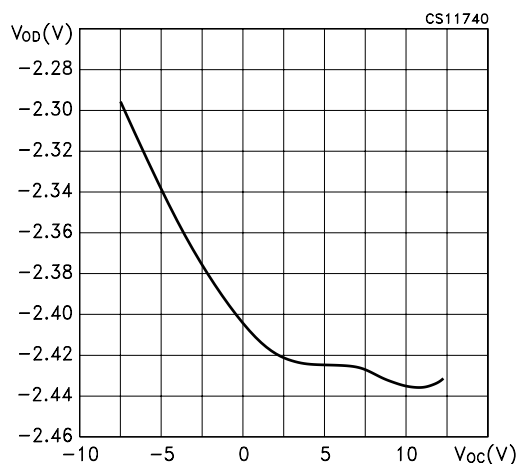

Figure 10 : Driver Short Circuit Current vs. Line Voltage (Output Low)

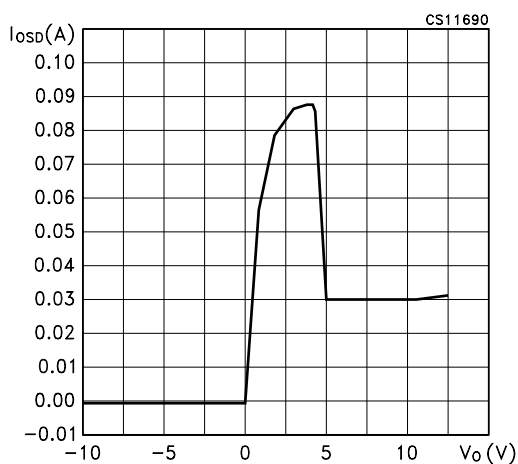
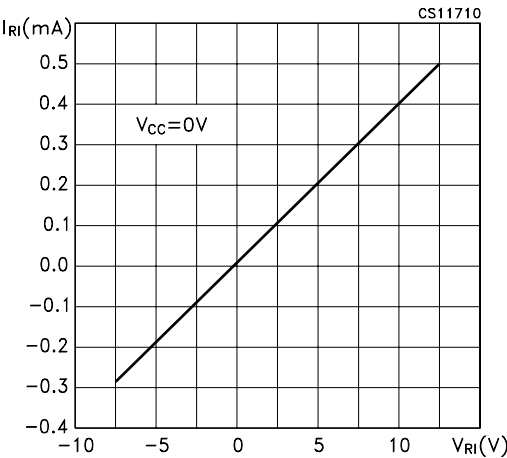
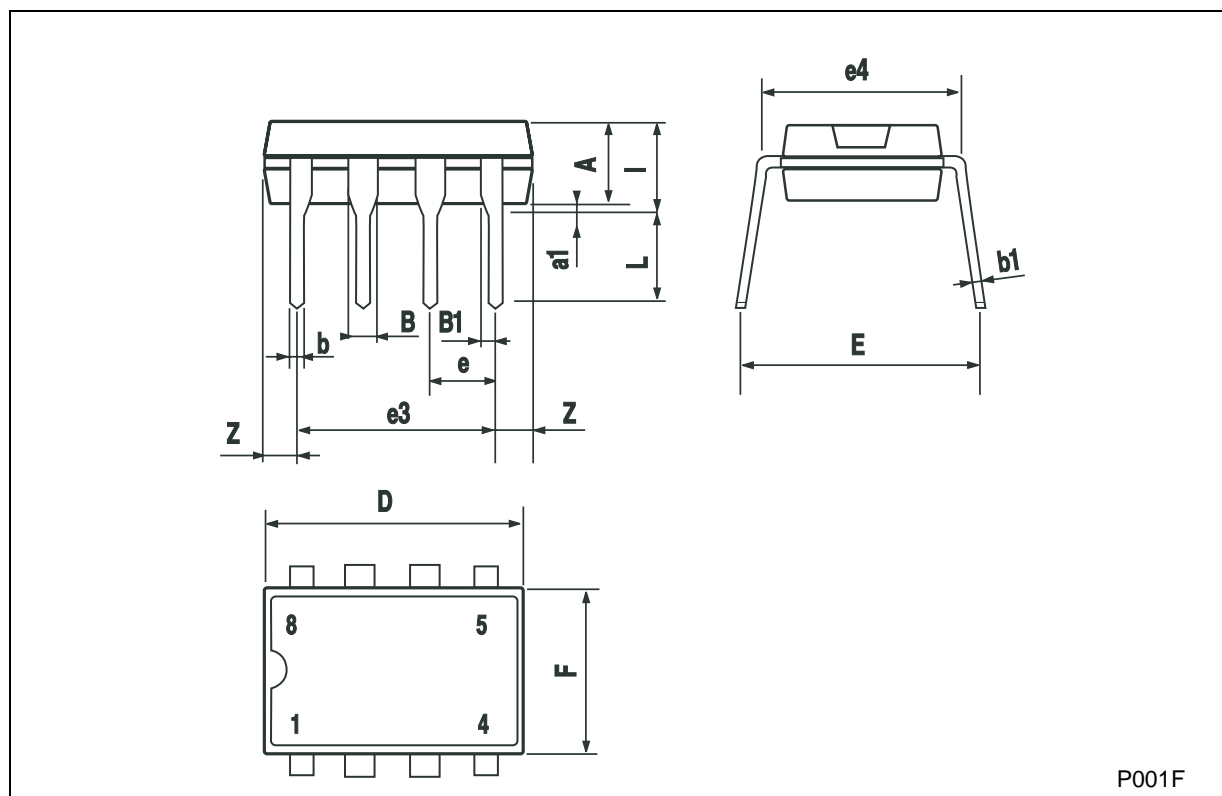

Figure 11 : Receiver Input Current vs Input Voltage



Plastic DIP-8 MECHANICAL DATA

DIM.	mm.			inch		
	MIN.	TYP.	MAX.	MIN.	TYP.	MAX.
A		3.3			0.130	
a1	0.7			0.028		
B	1.39		1.65	0.055		0.065
B1	0.91		1.04	0.036		0.041
b		0.5			0.020	
b1	0.38		0.5	0.015		0.020
D			9.8			0.386
E		8.8			0.346	
e		2.54			0.100	
e3		7.62			0.300	
e4		7.62			0.300	
F			7.1			0.280
l			4.8			0.189
L		3.3			0.130	
Z	0.44		1.6	0.017		0.063



SO-8 MECHANICAL DATA

DIM.	mm.			inch		
	MIN.	TYP.	MAX.	MIN.	TYP.	MAX.
A			1.75			0.068
a1	0.1		0.25	0.003		0.009
a2			1.65			0.064
a3	0.65		0.85	0.025		0.033
b	0.35		0.48	0.013		0.018
b1	0.19		0.25	0.007		0.010
C	0.25		0.5	0.010		0.019
c1	45° (typ.)					
D	4.8		5.0	0.189		0.196
E	5.8		6.2	0.228		0.244
e		1.27			0.050	
e3		3.81			0.150	
F	3.8		4.0	0.149		0.157
L	0.4		1.27	0.015		0.050
M			0.6			0.023
S	8° (max.)					

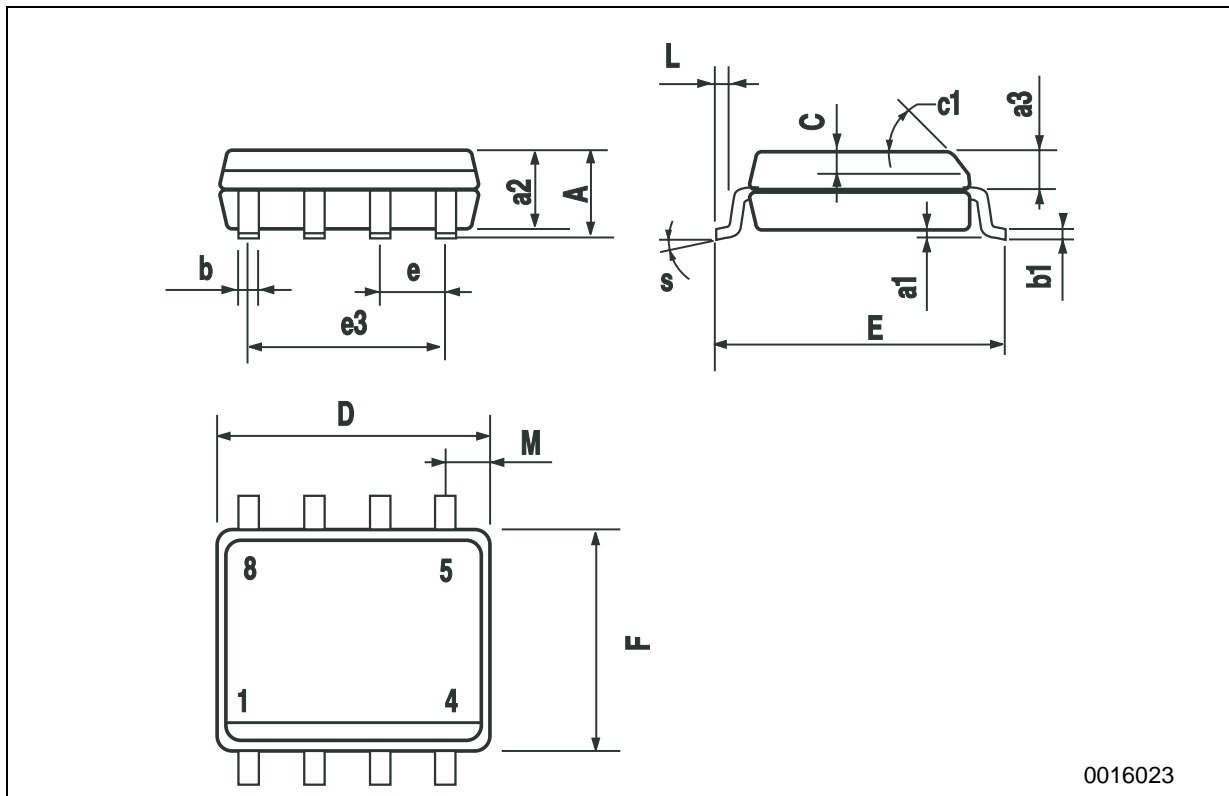

0016023

Information furnished is believed to be accurate and reliable. However, STMicroelectronics assumes no responsibility for the consequences of use of such information nor for any infringement of patents or other rights of third parties which may result from its use. No license is granted by implication or otherwise under any patent or patent rights of STMicroelectronics. Specifications mentioned in this publication are subject to change without notice. This publication supersedes and replaces all information previously supplied. STMicroelectronics products are not authorized for use as critical components in life support devices or systems without express written approval of STMicroelectronics.

© The ST logo is a registered trademark of STMicroelectronics

© 2002 STMicroelectronics - Printed in Italy - All Rights Reserved
STMicroelectronics GROUP OF COMPANIES

Australia - Brazil - Canada - China - Finland - France - Germany - Hong Kong - India - Israel - Italy - Japan - Malaysia - Malta - Morocco
Singapore - Spain - Sweden - Switzerland - United Kingdom - United States.

© <http://www.st.com>

