



ST3232

3 to 5.5V, Low power, up to 400Kbps
RS-232 Drivers and Receivers

Feature summary

- 300 μ A supply current
- 300Kbps minimum guaranteed data rate
- 6V/ μ s minimum guaranteed slew rate
- Meet EIA/TIA-232 specifications down to 3V
- Available in DIP-16, SO-16, SO-16 large and TSSOP16

Description

The ST3232 is a 3V powered EIA/TIA-232 and V.28/V.24 communication interface with low power requirements, high data-rate capabilities.

ST3232 has a proprietary low dropout transmitter output stage providing true RS-232 performance from 3 to 5.5V supplies. The device requires only four small 0.1mF standard external capacitors for operations from 3V supply.

The ST3232 has two receivers and two drivers.

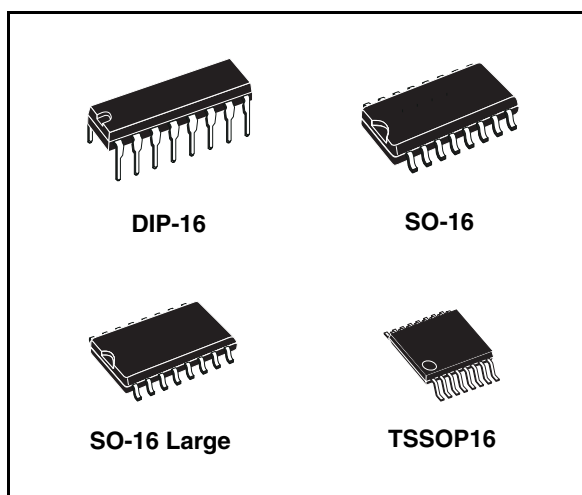

The device is guaranteed to run at data rates of 250Kbps while maintaining RS-232 output levels. Typical applications are Notebook, Subnotebook and Palmtop Computers, Battery Powered Equipment, Hand-Held Equipment, Peripherals and Printers.

Order code

Part number	Temp. range	Package	Packaging
ST3232CN	0 to 70 °C	DIP-16	25parts per tube / 40tube per box
ST3232BN	-40 to 85 °C	DIP-16	25parts per tube / 40tube per box
ST3232CDR	0 to 70 °C	SO-16 (Tape & Reel)	2500 parts per reel
ST3232BDR	-40 to 85 °C	SO-16 (Tape & Reel)	2500 parts per reel
ST3232CWR	0 to 70 °C	SO-16 Large (Tape & Reel)	1000 parts per reel
ST3232BWR	-40 to 85 °C	SO-16 Large (Tape & Reel)	1000 parts per reel
ST3232CTR	0 to 70 °C	TSSOP16 (Tape & Reel)	2500 parts per reel
ST3232BTR	-40 to 85 °C	TSSOP16 (Tape & Reel)	2500 parts per reel

Contents

1	Pin configuration	3
2	Absolute maximum ratings	4
3	Electrical characteristics	5
4	Application	7
5	Typical performance characteristics	8
6	Package mechanical data	10
7	Revision history	18

1 Pin configuration

Figure 1. Pin connection

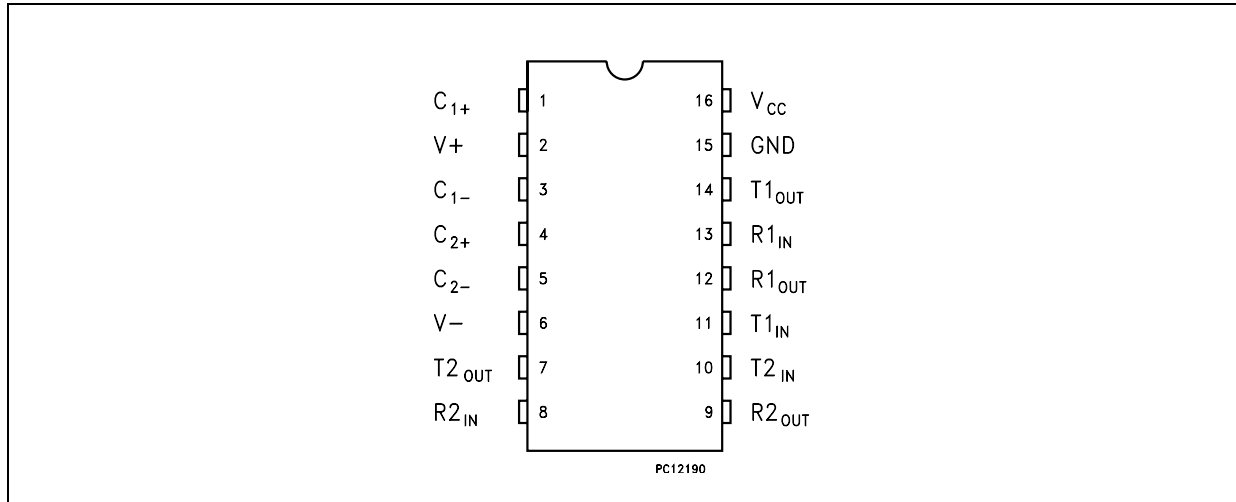

Table 1. Pin description

Pin N°	Symbol	Name and function
1	C ₁₊	Positive terminal for the first charge pump capacitor
2	V+	Doubled voltage terminal
3	C ₁₋	Negative Terminal for the first charge pump capacitor
4	C ₂₊	Positive terminal for the second charge pump capacitor
5	C ₂₋	Negative terminal for the second charge pump capacitor
6	V-	Inverted voltage terminal
7	T _{2OUT}	Second transmitter output voltage
8	R _{2IN}	Second receiver input voltage
9	R _{2OUT}	Second receiver output voltage
10	T _{2IN}	Second transmitter input voltage
11	T _{1IN}	First transmitter input voltage
12	R _{1OUT}	First receiver output voltage
13	R _{1IN}	First receiver input voltage
14	T _{1OUT}	First transmitter output voltage
15	GND	Ground
16	V _{CC}	Supply voltage

2 Absolute maximum ratings

Table 2. Absolute maximum ratings

Symbol	Parameter	Value	Unit
V_{CC}	Supply voltage	-0.3 to 6	V
V+	Doubled voltage terminal	$(V_{CC} - 0.3)$ to 7	V
V-	Inverted voltage terminal	0.3 to -7	V
$V+ + V- $		13	V
T_{IN}	Transmitter input voltage range	-0.3 to 6	V
R_{IN}	Receiver input voltage range	± 25	V
T_{OUT}	Transmitter output voltage range	± 13.2	V
R_{OUT}	Receiver output voltage range	-0.3 to $(V_{CC} + 0.3)$	V
t_{SHORT}	Transmitter output short to gnd time	Continuous	

Note: Absolute Maximum Ratings are those values beyond which damage to the device may occur. Functional operation under these condition is not implied. V+ and V- can have a maximum magnitude of +7V, but their absolute addition can not exceed 13 V.

3 Electrical characteristics

Table 3. Electrical characteristics ($C_1 - C_4 = 0.1\mu\text{F}$, $V_{\text{CC}} = 3\text{V}$ to 5.5V , $T_A = -40$ to 85°C , unless otherwise specified. Typical values are referred to $T_A = 25^\circ\text{C}$)

Symbol	Parameter	Test conditions	Min.	Typ.	Max.	Unit
I_{SUPPLY}	V_{CC} Power supply current	No Load, $V_{\text{CC}} = 3\text{V} \pm 10\%$, $T_A = 25^\circ\text{C}$		0.3	1	mA
		No Load, $V_{\text{CC}} = 5\text{V} \pm 10\%$, $T_A = 25^\circ\text{C}$		1	2	mA

Table 4. Logic input ($C_1 - C_4 = 0.1\mu\text{F}$, $V_{\text{CC}} = 3\text{V}$ to 5.5V , $T_A = -40$ to 85°C , unless otherwise specified. Typical values are referred to $T_A = 25^\circ\text{C}$)

Symbol	Parameter	Test conditions	Min.	Typ.	Max.	Unit
V_{TIL}	Input logic threshold low	T-IN ⁽¹⁾			0.8	V
V_{TIH}	Input logic threshold high	$V_{\text{CC}} = 3.3\text{V}$	2			V
		$V_{\text{CC}} = 5\text{V}$	2.4			
I_{IL}	Input leakage current	T-IN		± 0.01	± 1	μA

1. Transmitter input hysteresis is typically 250mV.

Table 5. Transmitter ($C_1 - C_4 = 0.1\mu\text{F}$ tested at $3.3\text{V} \pm 10\%$, $V_{\text{CC}} = 3\text{V}$ to 5.5V , $T_A = -40$ to 85°C , unless otherwise specified. Typical values are referred to $T_A = 25^\circ\text{C}$)

Symbol	Parameter	Test conditions	Min.	Typ.	Max.	Unit
V_{TOUT}	Output voltage swing	All transmitter outputs are loaded with $3\text{k}\Omega$ to GND	± 5	± 5.4		V
R_{TOUT}	Transmitter output resistance	$V_{\text{CC}} = V_+ = V_- = 0\text{V}$, $V_{\text{OUT}} = \pm 2\text{V}$	300	10M		Ω
I_{TSC}	Output short circuit current	$V_{\text{CC}} = 3\text{V}$ or 5V , $V_{\text{OUT}} = \pm 12$			± 60	mA

Table 6. Receiver ($C_1 - C_4 = 0.1\mu\text{F}$ tested at $3.3\text{V} \pm 10\%$, $V_{\text{CC}} = 3\text{V}$ to 5.5V , $T_A = -40$ to 85°C , unless otherwise specified. Typical values are referred to $T_A = 25^\circ\text{C}$)

Symbol	Parameter	Test conditions	Min.	Typ.	Max.	Unit
V_{RIN}	Receiver input voltage operating range		-25		25	V
V_{RIL}	RS-232 Input threshold low	$T_A = 25^\circ\text{C}$, $V_{\text{CC}} = 3.3\text{V}$	0.6	1.1		V
		$T_A = 25^\circ\text{C}$, $V_{\text{CC}} = 5\text{V}$	0.8	1.5		
V_{RIH}	RS-232 Input threshold high	$T_A = 25^\circ\text{C}$, $V_{\text{CC}} = 3.3\text{V}$		1.5	2.4	V
		$T_A = 25^\circ\text{C}$, $V_{\text{CC}} = 5\text{V}$		1.8	2.4	
V_{RIHYS}	Input hysteresis			0.3		V
R_{RIN}	Input resistance	$T_A = 25^\circ\text{C}$	3	5	7	k Ω
V_{ROL}	TTL/CMOS Output voltage low	$I_{\text{OUT}} = 1.6\text{mA}$			0.4	V
V_{ROH}	TTL/CMOS Output voltage high	$I_{\text{OUT}} = -1\text{mA}$	$V_{\text{CC}} - 0.6$	$V_{\text{CC}} - 0.1$		V

Table 7. Timing characteristics ($C_1 - C_4 = 0.1\mu\text{F}$ tested at $3.3\text{V}\pm 10\%$, $V_{\text{CC}} = 3\text{V}$ to 5.5V , $T_A = -40$ to 85°C , unless otherwise specified. Typical values are referred to $T_A = 25^\circ\text{C}$)

Symbol	Parameter	Test conditions	Min.	Typ.	Max.	Unit
D_R	Data transfer rate	$R_L = 3\text{K}\Omega$, $C_{L2} = 1000\text{pF}$ one transmitter switching	300	400		Kbps
t_{PHLR} t_{PLHR}	Propagation delay input to output	$R_{\text{XIN}} = R_{\text{XOUT}}$, $C_L = 150\text{pF}$		0.2		μs
$ t_{\text{PHLT}} - t_{\text{THL}} $	Transmitter propagation delay difference	(Note 1)		100		ns
$ t_{\text{PHLR}} - t_{\text{THR}} $	Receiver propagation delay difference			50		ns
S_{RT}	Transition slew rate	$T_A = 25^\circ\text{C}$ $R_L = 3\text{K}\Omega$ to $7\text{K}\Omega$ $V_{\text{CC}} = 3.3\text{V}$ measured from $+3\text{V}$ to -3V or -3V to $+3\text{V}$ $C_L = 150\text{pF}$ to 1000pF $C_L = 150\text{pF}$ to 2500pF	6 4		30 30	$\text{V}/\mu\text{s}$ $\text{V}/\mu\text{s}$

Note: 1 Transmitter Skew is measured at the transmitter zero cross points

4 Application

Figure 2. Application circuits

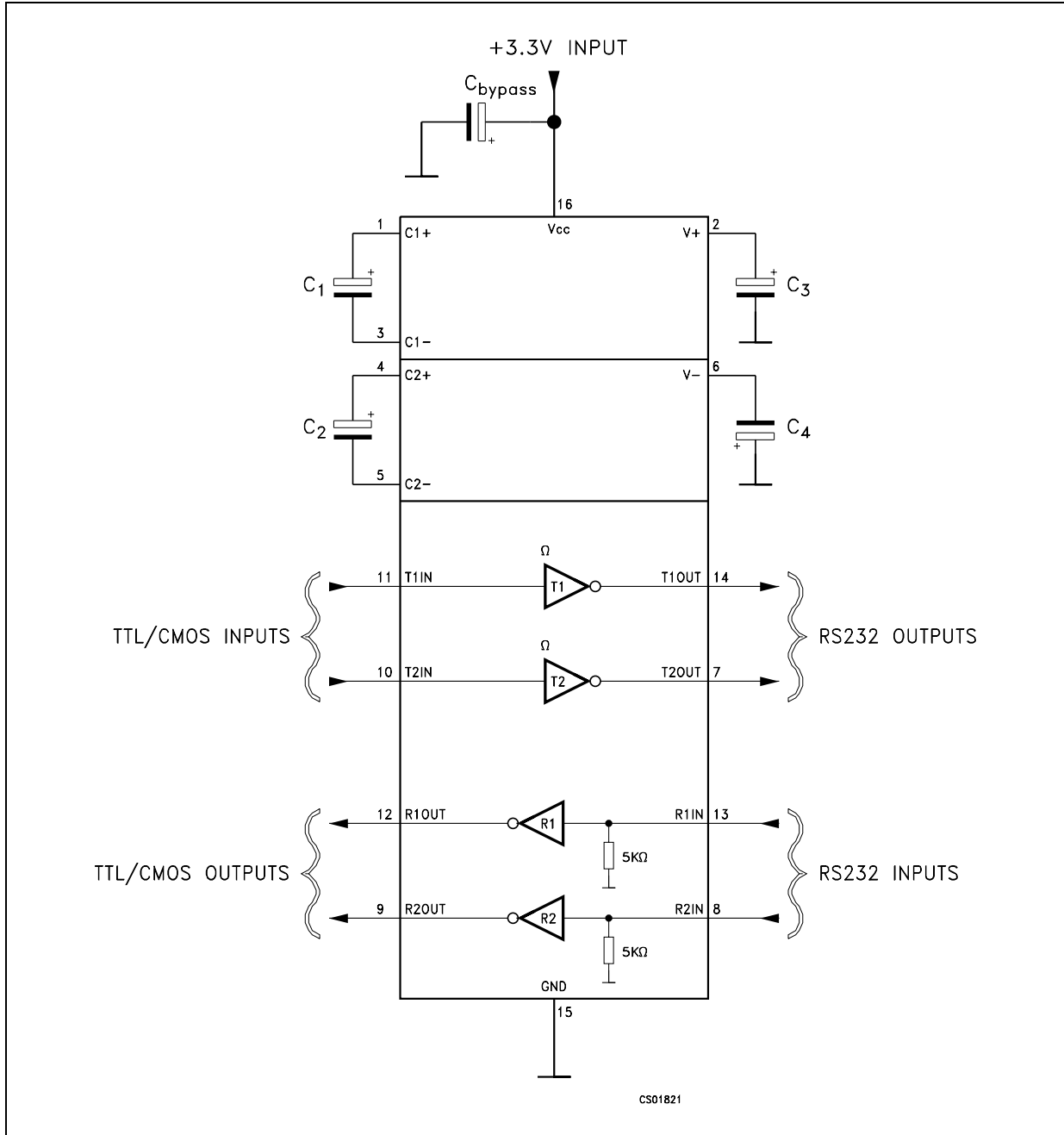

Table 8. Capacitance value (μF)

V_{CC}	C1	C2	C3	C4	C_{bypass}
3.0 to 3.6	0.1	0.1	0.1	0.1	0.1
4.5 to 5.5	0.047	0.33	0.33	0.33	0.33

5 Typical performance characteristics

(unless otherwise specified $T_J = 25^\circ\text{C}$)

Figure 3. Driver voltage transfer characteristics for transmitter input

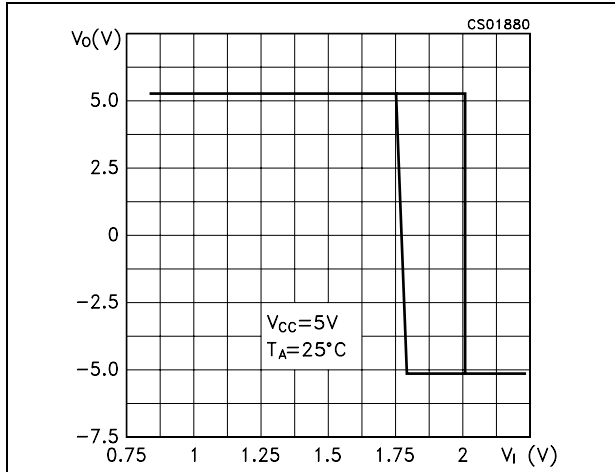

Figure 4. Driver voltage transfer characteristics for receiver inputs

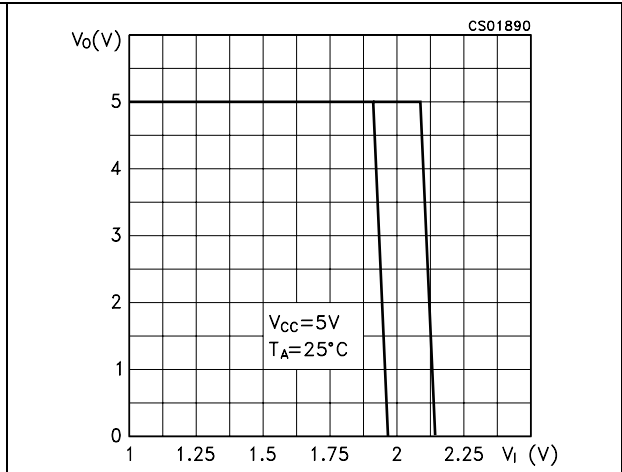

Figure 5. Output current vs output low voltage

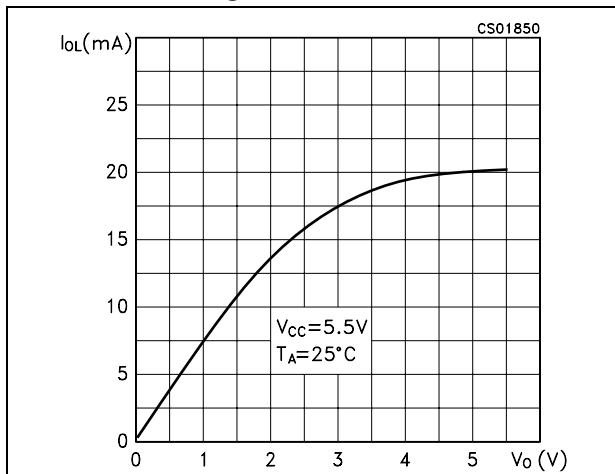

Figure 6. Output current vs output low voltage

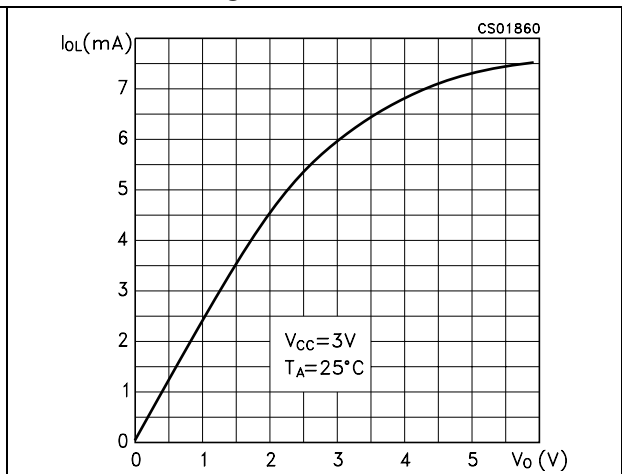

Figure 7. Output current vs output high voltage

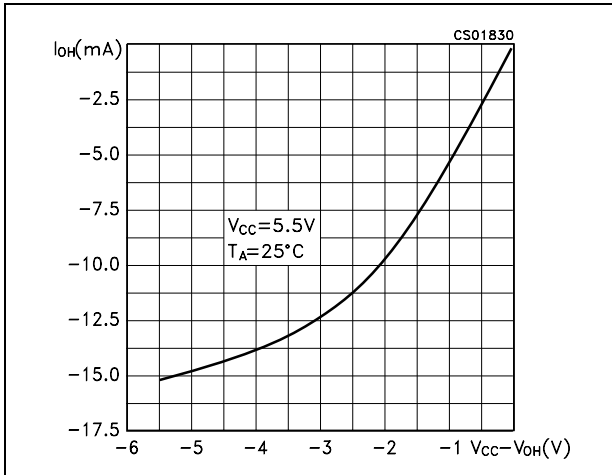

Figure 8. Output current vs output high voltage

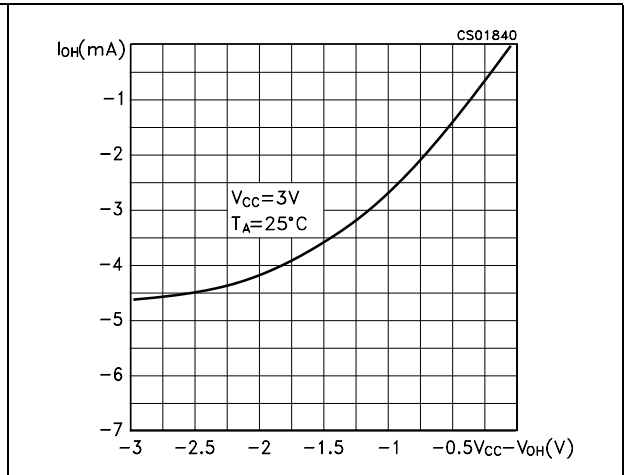
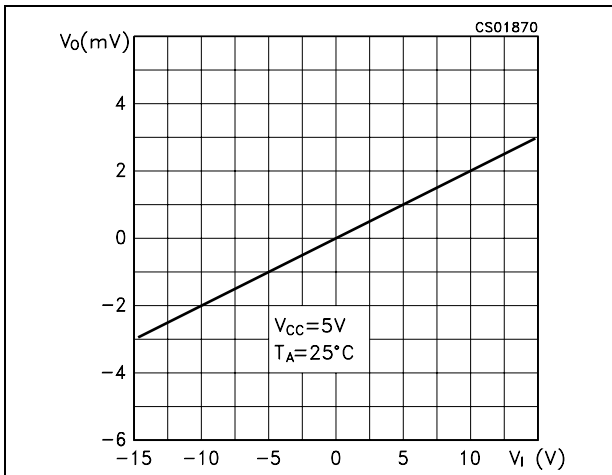

Figure 9. Receiver input resistance



6 Package mechanical data

In order to meet environmental requirements, ST offers these devices in ECOPACK® packages. These packages have a Lead-free second level interconnect. The category of second Level Interconnect is marked on the package and on the inner box label, in compliance with JEDEC Standard JESD97. The maximum ratings related to soldering conditions are also marked on the inner box label. ECOPACK is an ST trademark. ECOPACK specifications are available at: www.st.com.

Plastic DIP-16 (0.25) MECHANICAL DATA

DIM.	mm.			inch		
	MIN.	TYP	MAX.	MIN.	TYP.	MAX.
a1	0.51			0.020		
B	0.77		1.65	0.030		0.065
b		0.5			0.020	
b1		0.25			0.010	
D			20			0.787
E		8.5			0.335	
e		2.54			0.100	
e3		17.78			0.700	
F			7.1			0.280
I			5.1			0.201
L		3.3			0.130	
Z			1.27			0.050

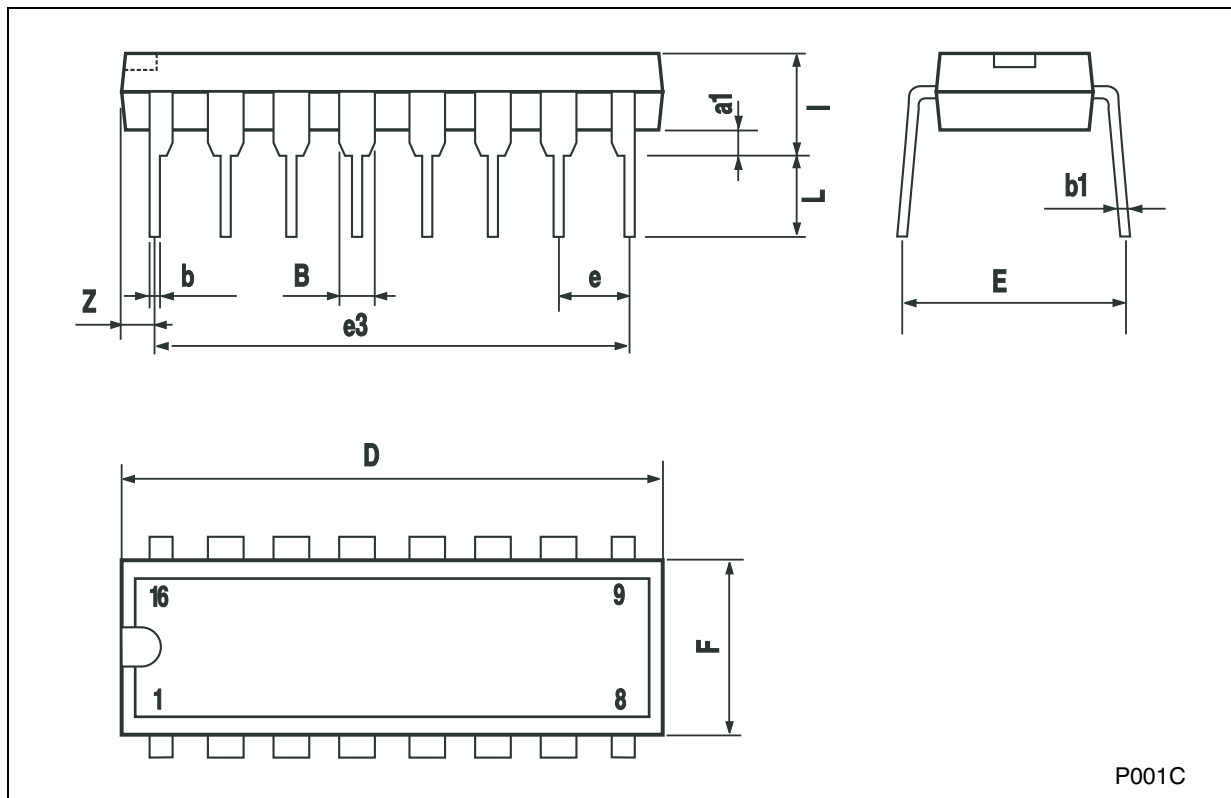

SO-16 MECHANICAL DATA

DIM.	mm.			inch		
	MIN.	TYP	MAX.	MIN.	TYP.	MAX.
A			1.75			0.068
a1	0.1		0.25	0.004		0.010
a2			1.64			0.063
b	0.35		0.46	0.013		0.018
b1	0.19		0.25	0.007		0.010
C		0.5			0.019	
c1	45° (typ.)					
D	9.8		10	0.385		0.393
E	5.8		6.2	0.228		0.244
e		1.27			0.050	
e3		8.89			0.350	
F	3.8		4.0	0.149		0.157
G	4.6		5.3	0.181		0.208
L	0.5		1.27	0.019		0.050
M			0.62			0.024
S	8° (max.)					

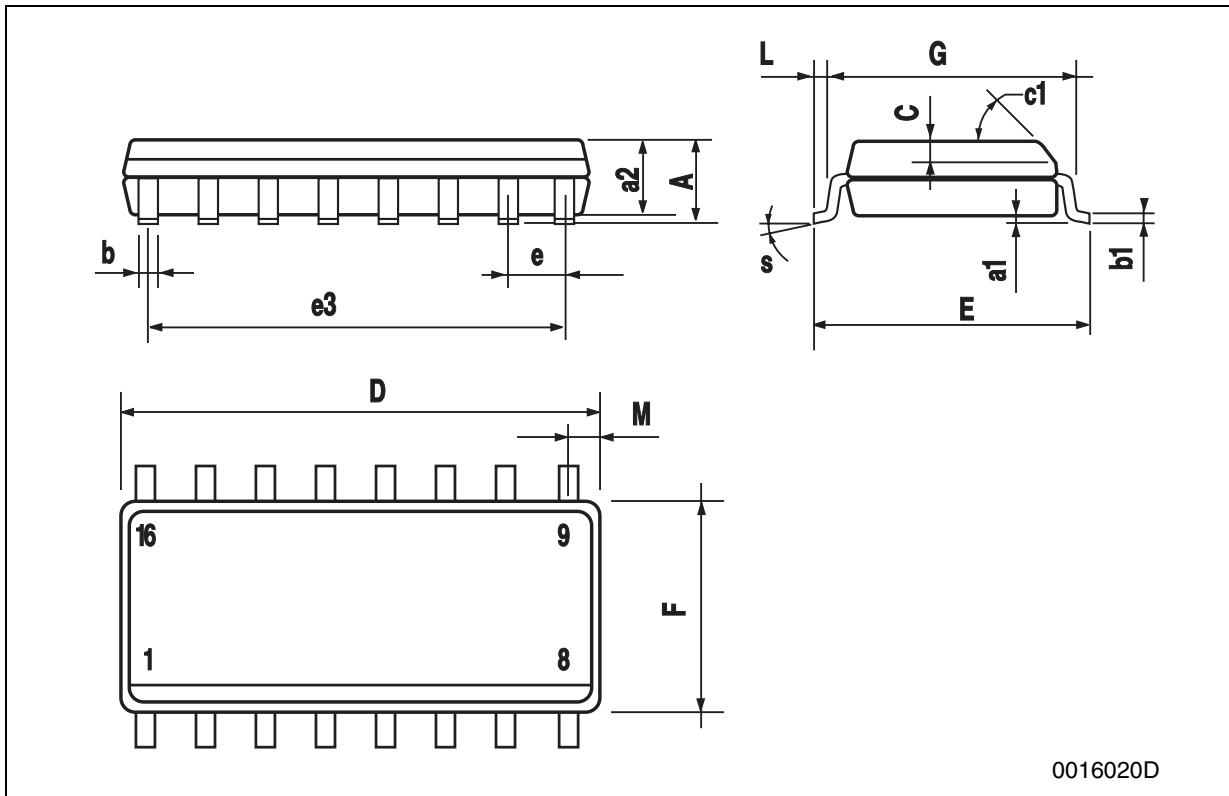

SO-16L MECHANICAL DATA

DIM.	mm.			inch		
	MIN.	TYP	MAX.	MIN.	TYP.	MAX.
A			2.65			0.104
a1	0.1		0.2	0.004		0.008
a2			2.45			0.096
b	0.35		0.49	0.014		0.019
b1	0.23		0.32	0.009		0.012
C		0.5			0.020	
c1	45° (typ.)					
D	10.1		10.5	0.397		0.413
E	10.0		10.65	0.393		0.419
e		1.27			0.050	
e3		8.89			0.350	
F	7.4		7.6	0.291		0.300
G						
L	0.5		1.27	0.020		0.050
M			0.75			0.029
S	8			° (max.)		

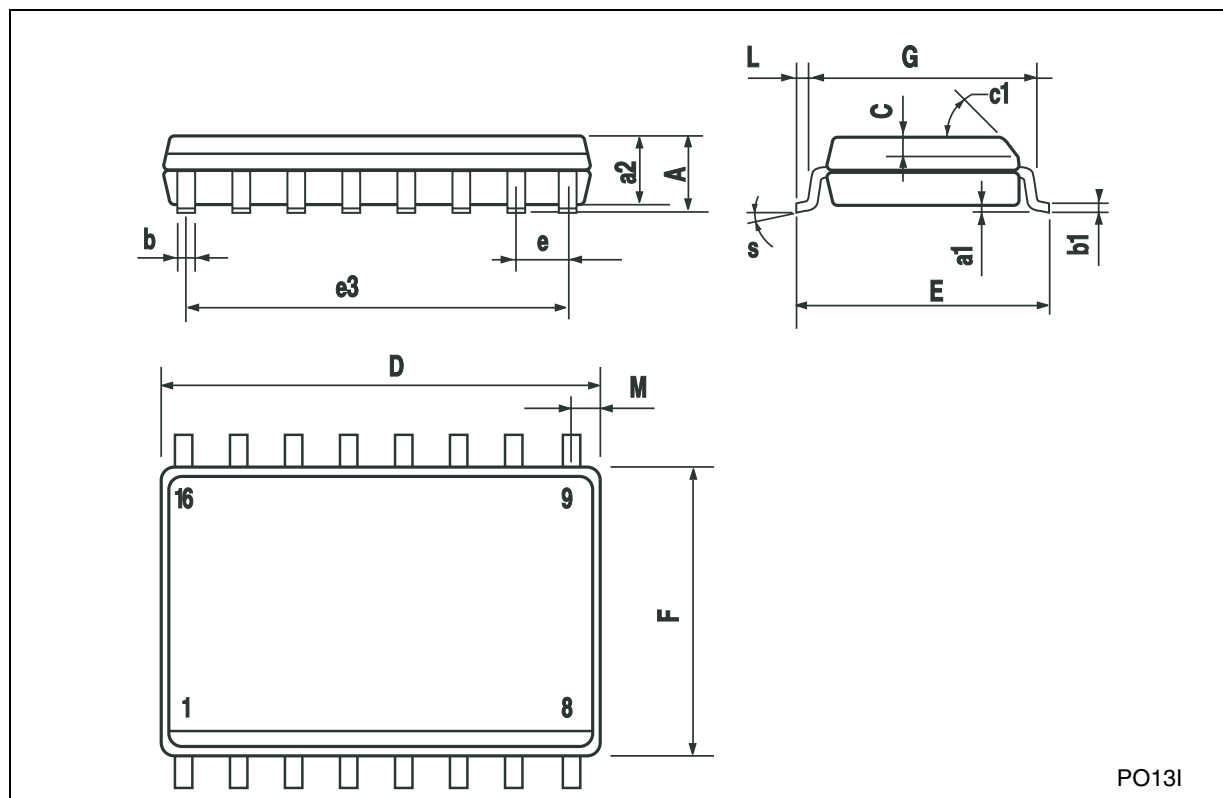

TSSOP16 MECHANICAL DATA

DIM.	mm.			inch		
	MIN.	TYP	MAX.	MIN.	TYP.	MAX.
A			1.2			0.047
A1	0.05		0.15	0.002	0.004	0.006
A2	0.8	1	1.05	0.031	0.039	0.041
b	0.19		0.30	0.007		0.012
c	0.09		0.20	0.004		0.0079
D	4.9	5	5.1	0.193	0.197	0.201
E	6.2	6.4	6.6	0.244	0.252	0.260
E1	4.3	4.4	4.48	0.169	0.173	0.176
e		0.65 BSC			0.0256 BSC	
K	0°		8°	0°		8°
L	0.45	0.60	0.75	0.018	0.024	0.030

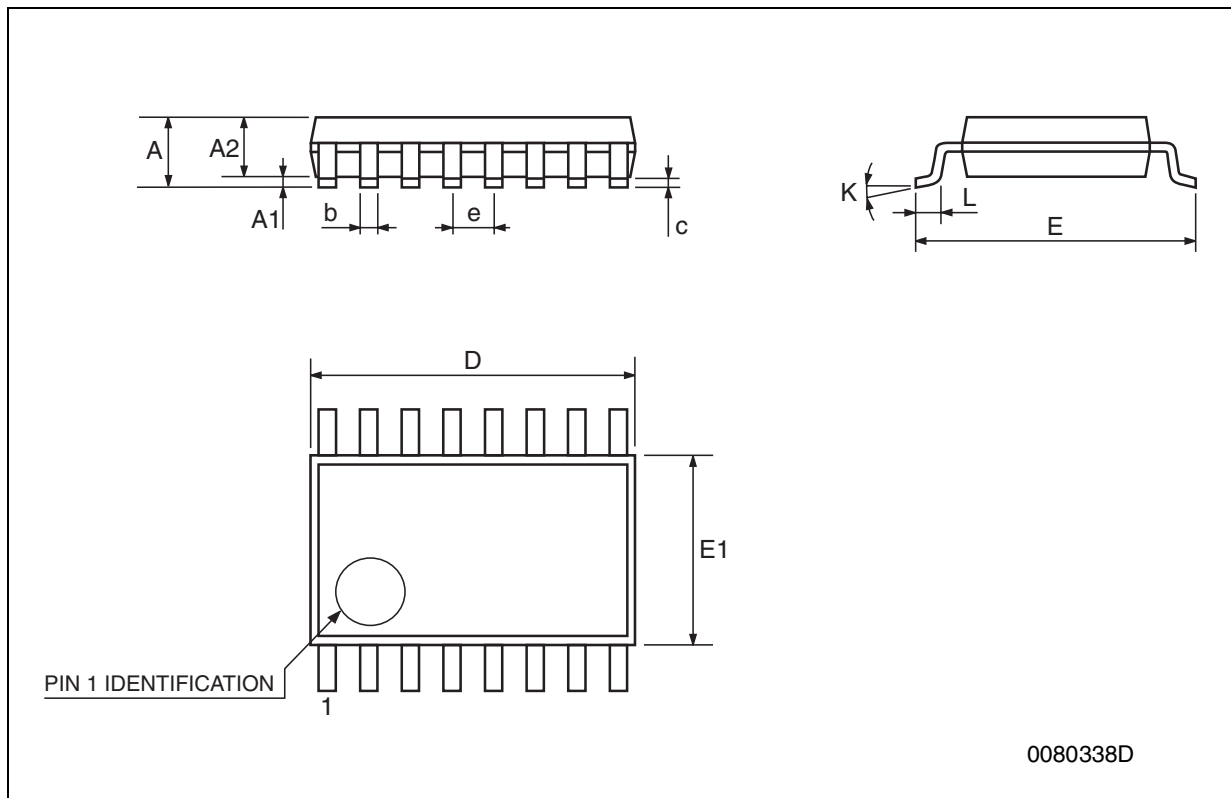

Tape & Reel SO-16 MECHANICAL DATA

DIM.	mm.			inch		
	MIN.	TYP	MAX.	MIN.	TYP.	MAX.
A			330			12.992
C	12.8		13.2	0.504		0.519
D	20.2			0.795		
N	60			2.362		
T			22.4			0.882
Ao	6.45		6.65	0.254		0.262
Bo	10.3		10.5	0.406		0.414
Ko	2.1		2.3	0.082		0.090
Po	3.9		4.1	0.153		0.161
P	7.9		8.1	0.311		0.319

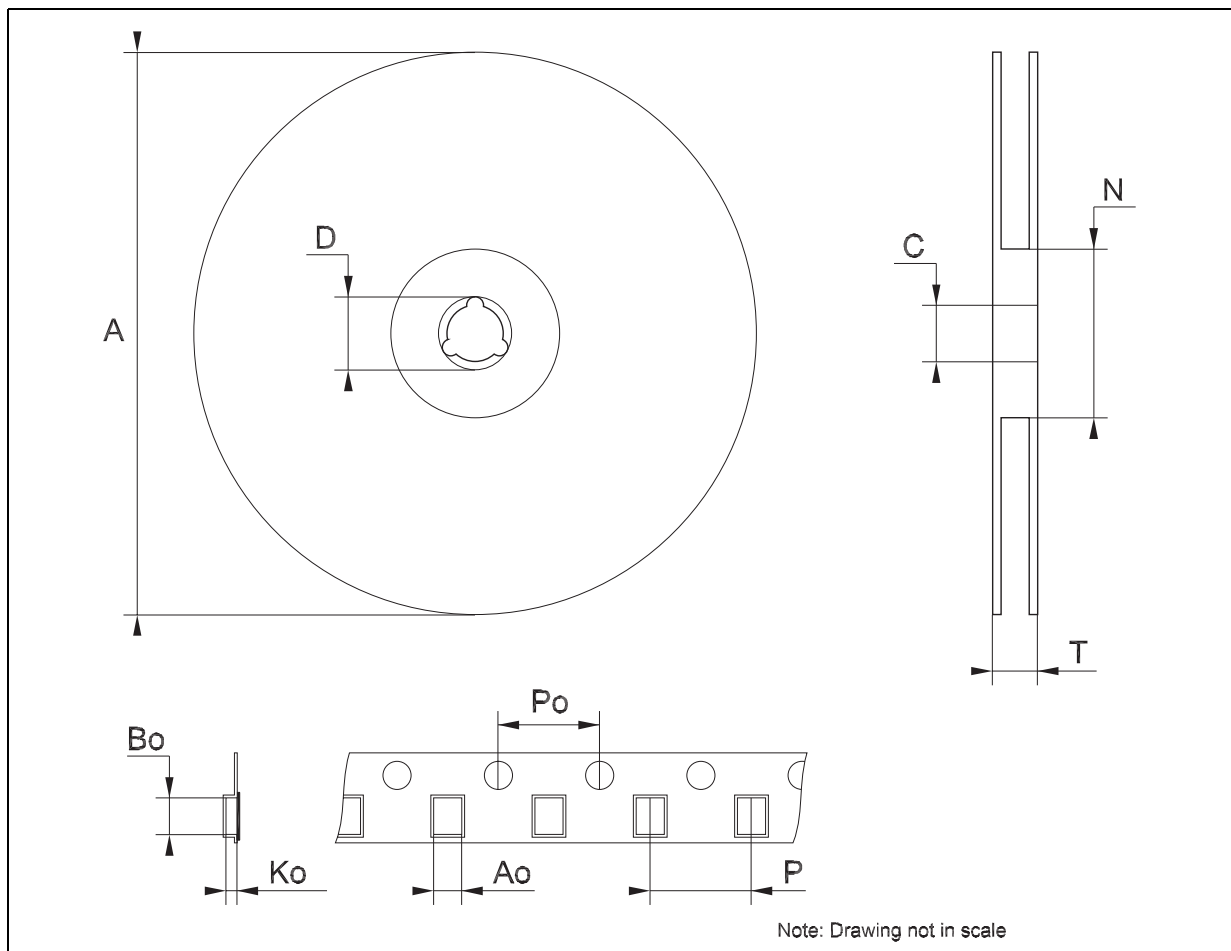

Tape & Reel SO-16L MECHANICAL DATA

DIM.	mm.			inch		
	MIN.	TYP	MAX.	MIN.	TYP.	MAX.
A			330			12.992
C	12.8		13.2	0.504		0.519
D	20.2			0.795		
N	60			2.362		
T			22.4			0.882
Ao	10.8		11.0	0.425		0.433
Bo	10.7		10.9	0.421		0.429
Ko	2.9		3.1	0.114		0.122
Po	3.9		4.1	0.153		0.161
P	11.9		12.1	0.468		0.476

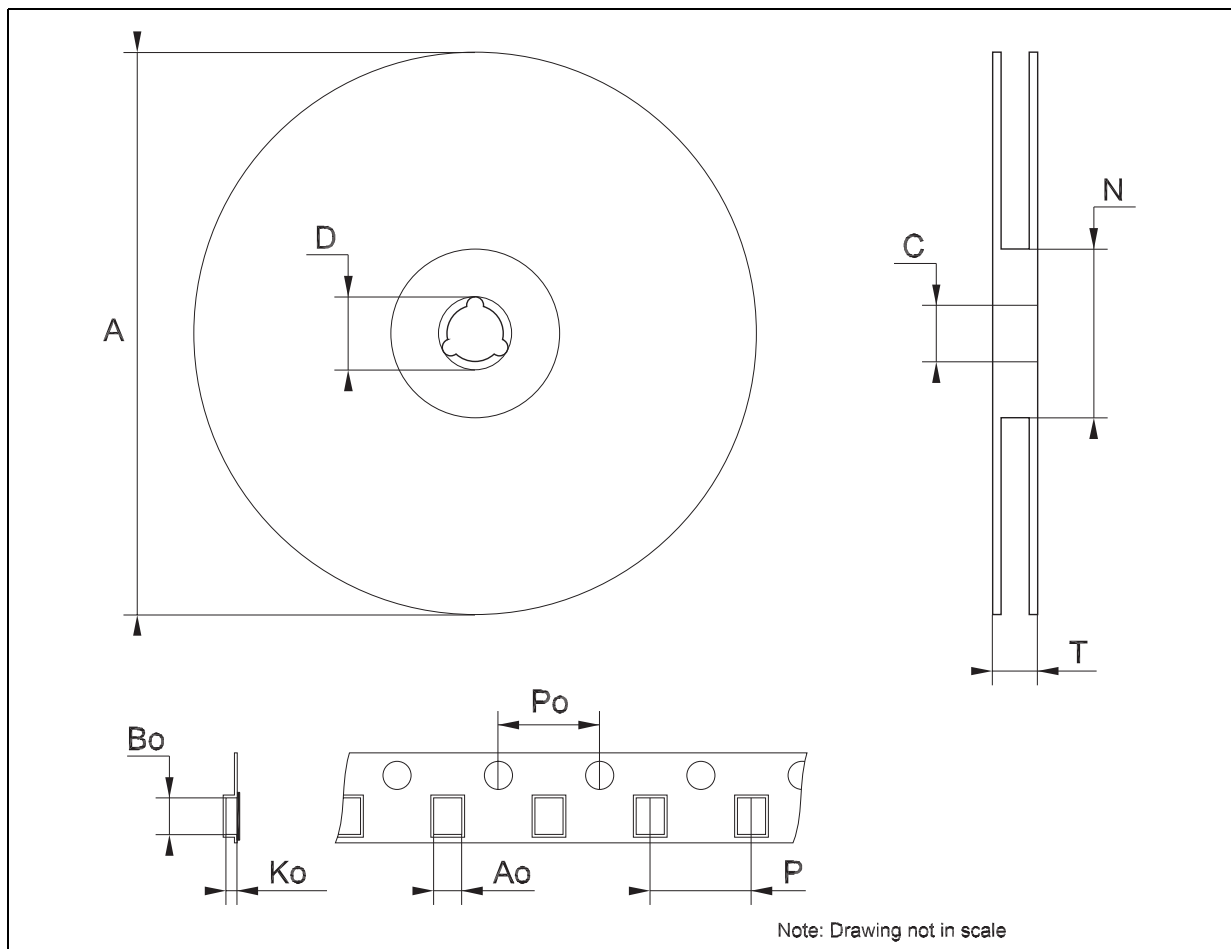

Tape & Reel TSSOP16 MECHANICAL DATA

DIM.	mm.			inch		
	MIN.	TYP	MAX.	MIN.	TYP.	MAX.
A			330			12.992
C	12.8		13.2	0.504		0.519
D	20.2			0.795		
N	60			2.362		
T			22.4			0.882
Ao	6.7		6.9	0.264		0.272
Bo	5.3		5.5	0.209		0.217
Ko	1.6		1.8	0.063		0.071
Po	3.9		4.1	0.153		0.161
P	7.9		8.1	0.311		0.319

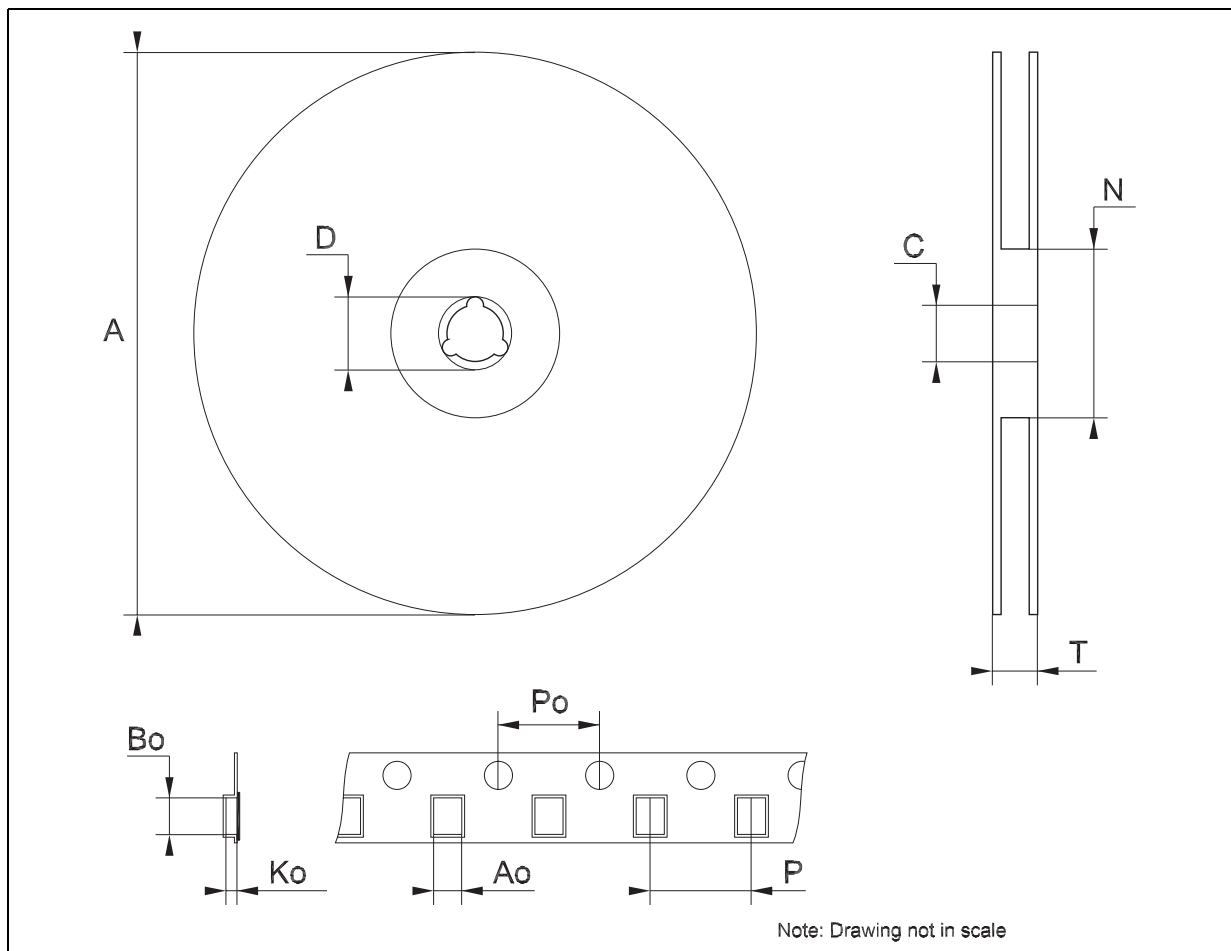

7 Revision history

Table 9. Revision history

Date	Revision	Changes
06-Sep-2006	8	Order codes has been updated and new template.
25-Oct-2006	9	Order codes has been updated.

Please Read Carefully:

Information in this document is provided solely in connection with ST products. STMicroelectronics NV and its subsidiaries ("ST") reserve the right to make changes, corrections, modifications or improvements, to this document, and the products and services described herein at any time, without notice.

All ST products are sold pursuant to ST's terms and conditions of sale.

Purchasers are solely responsible for the choice, selection and use of the ST products and services described herein, and ST assumes no liability whatsoever relating to the choice, selection or use of the ST products and services described herein.

No license, express or implied, by estoppel or otherwise, to any intellectual property rights is granted under this document. If any part of this document refers to any third party products or services it shall not be deemed a license grant by ST for the use of such third party products or services, or any intellectual property contained therein or considered as a warranty covering the use in any manner whatsoever of such third party products or services or any intellectual property contained therein.

UNLESS OTHERWISE SET FORTH IN ST'S TERMS AND CONDITIONS OF SALE ST DISCLAIMS ANY EXPRESS OR IMPLIED WARRANTY WITH RESPECT TO THE USE AND/OR SALE OF ST PRODUCTS INCLUDING WITHOUT LIMITATION IMPLIED WARRANTIES OF MERCHANTABILITY, FITNESS FOR A PARTICULAR PURPOSE (AND THEIR EQUIVALENTS UNDER THE LAWS OF ANY JURISDICTION), OR INFRINGEMENT OF ANY PATENT, COPYRIGHT OR OTHER INTELLECTUAL PROPERTY RIGHT.

UNLESS EXPRESSLY APPROVED IN WRITING BY AN AUTHORIZED ST REPRESENTATIVE, ST PRODUCTS ARE NOT RECOMMENDED, AUTHORIZED OR WARRANTED FOR USE IN MILITARY, AIR CRAFT, SPACE, LIFE SAVING, OR LIFE SUSTAINING APPLICATIONS, NOR IN PRODUCTS OR SYSTEMS WHERE FAILURE OR MALFUNCTION MAY RESULT IN PERSONAL INJURY, DEATH, OR SEVERE PROPERTY OR ENVIRONMENTAL DAMAGE. ST PRODUCTS WHICH ARE NOT SPECIFIED AS "AUTOMOTIVE GRADE" MAY ONLY BE USED IN AUTOMOTIVE APPLICATIONS AT USER'S OWN RISK.

Resale of ST products with provisions different from the statements and/or technical features set forth in this document shall immediately void any warranty granted by ST for the ST product or service described herein and shall not create or extend in any manner whatsoever, any liability of ST.

ST and the ST logo are trademarks or registered trademarks of ST in various countries.

Information in this document supersedes and replaces all information previously supplied.

The ST logo is a registered trademark of STMicroelectronics. All other names are the property of their respective owners.

© 2006 STMicroelectronics - All rights reserved

STMicroelectronics group of companies

Australia - Belgium - Brazil - Canada - China - Czech Republic - Finland - France - Germany - Hong Kong - India - Israel - Italy - Japan - Malaysia - Malta - Morocco - Singapore - Spain - Sweden - Switzerland - United Kingdom - United States of America

www.st.com