

VERY LOW QUIESCENT CURRENT DUAL VOLTAGE REGULATOR

- $V_{O1} = 1.5, 1.8, 2.5, 2.8, 3.0, 3.3V$ FIXED
- $V_{O2} = 1.5, 1.8, 2.5, 2.8, 3.0, 3.3V$ FIXED OR ADJUSTABLE FROM 1.25 TO $V_I - V_{DROD}$
- GUARANTEED OUTPUT1 CURRENT: 1A
- GUARANTEED OUTPUT2 CURRENT: 1A
- $\pm 2\%$ OUTPUT TOLERANCE (AT 25°C)
- $\pm 3\%$ OUTPUT TOLERANCE OVER TEMP.
- TYPICAL DROPOUT 1.1V ($I_{O1} = I_{O2} = 1A$)
- INTERNAL POWER AND THERMAL LIMIT
- STABLE WITH LOW ESR OUTPUT CAPACITOR
- OPERATING TEMPERATURE RANGE: 0°C TO 125°C
- VERY LOW QUIESCENT CURRENT: 7mA MAX OVER TEMP.
- AVAILABLE IN SPAK AND IN DFN 5x6mm PACKAGE

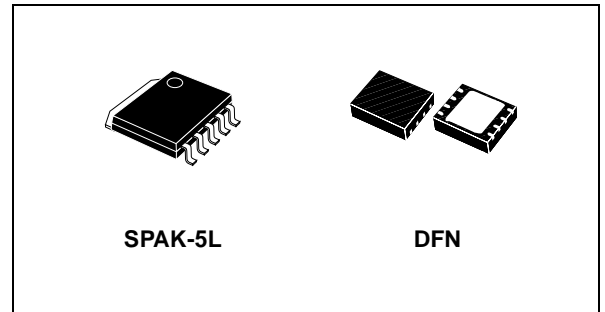

mounting package named DFN 5x6mm at 8 pins. The first regulator block supplies 1.5V, 1.8V, 2.5V, 2.8V, 3.0V, 3.3V depending on the chosen version. The second one may be fixed to the same values or adjustable from 1.25V to $V_I - V_{DROD}$ that could power several kind of different micro-controllers. Both outputs are current limited and over temperature protected. It is worth underlining the very good thermal performance of the packages SPAK and DFN with only 2°C/W of Thermal Resistance Junction to Case. Applications are HARD DISK, CD/DVD-ROM, CD/DVD-R/RW, COMBO (DVD-ROM+CD-R/RW).

DESCRIPTION

Specifically designed for data storage applications, this device integrates two voltage regulators, each one able to supply 1A and it is assembled in SPAK and in a new 8-PIN surface

Figure 1: Block Diagram Of Fixed/adj Version

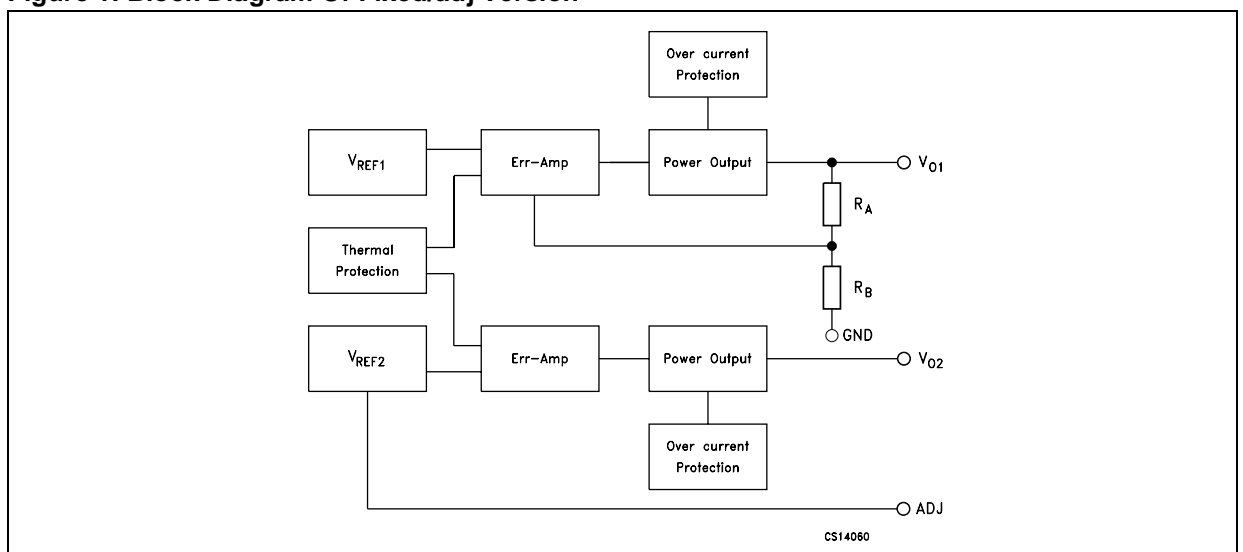

Figure 2: Block Diagram Of Fixed/fixed Version

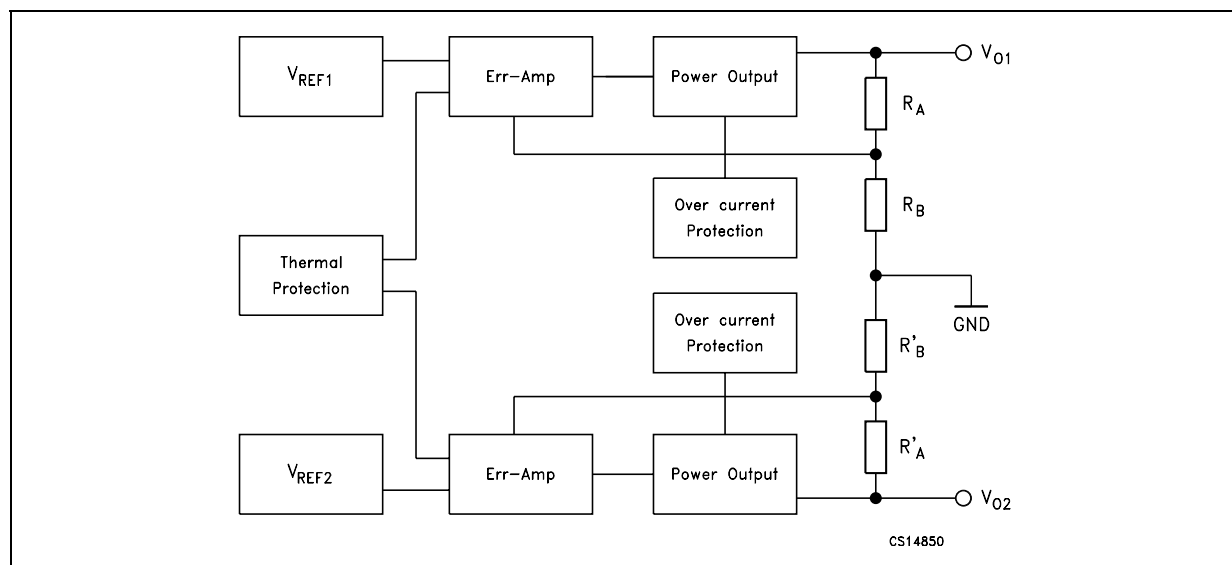

Table 1: Order Codes

V _{O1}	V _{O2}	SPAK	DFN	SHIPMENT ⁽¹⁾
1.5 V	1.5 V	ST2L05R1515K5 (*)	ST2L05R1515PS (*)	Tape & Reel
1.5 V	1.8 V	ST2L05R1518K5 (*)	ST2L05R1518PS (*)	Tape & Reel
1.5 V	2.5 V	ST2L05R1525K5 (*)	ST2L05R1525PS (*)	Tape & Reel
1.5 V	2.8 V	ST2L05R1528K5 (*)	ST2L05R1528PS (*)	Tape & Reel
1.5 V	3.0 V	ST2L05R1530K5 (*)	ST2L05R1530PS (*)	Tape & Reel
1.5 V	3.3 V	ST2L05R1533K5 (*)	ST2L05R1533PS (*)	Tape & Reel
1.5 V	ADJ	ST2L05R1500K5 (*)	ST2L05R1500PS (*)	Tape & Reel
1.8 V	1.5 V	ST2L05R1815K5 (*)	ST2L05R1815PS (*)	Tape & Reel
1.8 V	1.8 V	ST2L05R1818K5 (*)	ST2L05R1818PS (*)	Tape & Reel
1.8 V	2.5 V	ST2L05R1825K5 (*)	ST2L05R1825PS (*)	Tape & Reel
1.8 V	2.8 V	ST2L05R1828K5 (*)	ST2L05R1828PS (*)	Tape & Reel
1.8 V	3.0 V	ST2L05R1830K5 (*)	ST2L05R1830PS (*)	Tape & Reel
1.8 V	3.3 V	ST2L05R1833K5 (*)	ST2L05R1833PS (*)	Tape & Reel
1.8 V	ADJ	ST2L05R1800K5 (*)	ST2L05R1800PS (*)	Tape & Reel
2.5 V	1.5 V	ST2L05R2515K5 (*)	ST2L05R2515PS (*)	Tape & Reel
2.5 V	1.8 V	ST2L05R2518K5 (*)	ST2L05R2518PS (*)	Tape & Reel
2.5 V	2.5 V	ST2L05R2525K5 (*)	ST2L05R2525PS (*)	Tape & Reel
2.5 V	2.8 V	ST2L05R2528K5 (*)	ST2L05R2528PS (*)	Tape & Reel
2.5 V	3.0 V	ST2L05R2530K5 (*)	ST2L05R2530PS (*)	Tape & Reel
2.5 V	3.3 V	ST2L05R2533K5 (*)	ST2L05R2533PS (*)	Tape & Reel
2.5 V	ADJ	ST2L05R2500K5 (*)	ST2L05R2500PS (*)	Tape & Reel
2.8 V	1.5 V	ST2L05R2815K5 (*)	ST2L05R2815PS (*)	Tape & Reel
2.8 V	1.8 V	ST2L05R2818K5 (*)	ST2L05R2818PS (*)	Tape & Reel
2.8 V	2.5 V	ST2L05R2825K5 (*)	ST2L05R2825PS (*)	Tape & Reel
2.8 V	2.8 V	ST2L05R2828K5 (*)	ST2L05R2828PS (*)	Tape & Reel
2.8 V	3.0 V	ST2L05R2830K5 (*)	ST2L05R2830PS (*)	Tape & Reel
2.8 V	3.3 V	ST2L05R2833K5 (*)	ST2L05R2833PS (*)	Tape & Reel
2.8 V	ADJ	ST2L05R2800K5 (*)	ST2L05R2800PS (*)	Tape & Reel
3.0 V	1.5 V	ST2L05R3015K5 (*)	ST2L05R3015PS (*)	Tape & Reel
3.0 V	1.8 V	ST2L05R3018K5 (*)	ST2L05R3018PS (*)	Tape & Reel
3.0 V	2.5 V	ST2L05R3025K5 (*)	ST2L05R3025PS (*)	Tape & Reel
3.0 V	2.8 V	ST2L05R3028K5 (*)	ST2L05R3028PS (*)	Tape & Reel
3.0 V	3.0 V	ST2L05R3030K5 (*)	ST2L05R3030PS (*)	Tape & Reel
3.0 V	3.3 V	ST2L05R3033K5 (*)	ST2L05R3033PS (*)	Tape & Reel
3.0 V	ADJ	ST2L05R3000K5 (*)	ST2L05R3000PS (*)	Tape & Reel
3.3 V	1.5 V	ST2L05R3315K5 (*)	ST2L05R3315PS (*)	Tape & Reel
3.3 V	1.8 V	ST2L05R3318K5 (*)	ST2L05R3318PS (*)	Tape & Reel
3.3 V	2.5 V	ST2L05R3325K5 (*)	ST2L05R3325PS	Tape & Reel
3.3 V	2.8 V	ST2L05R3328K5 (*)	ST2L05R3328PS (*)	Tape & Reel
3.3 V	3.0 V	ST2L05R3330K5 (*)	ST2L05R3330PS (*)	Tape & Reel
3.3 V	3.3 V	ST2L05R3333K5 (*)	ST2L05R3333PS (*)	Tape & Reel
3.3 V	ADJ	ST2L05R3300K5	ST2L05R3300PS	Tape & Reel

(*) Available on request.

(1) For Tube Shipment, change "R" with "-" in the relevant ordering code, DFN is available only in Tape & Reel.

Table 2: Absolute Maximum Ratings

Symbol	Parameter	Value	Unit
V_I	Operating Input Voltage	10	V
P_D	Power Dissipation	Internally Limited	
I_{OSH}	Short Circuit Output Current - 3.3 V and adjustable output	Internally Limited	
T_{op}	Operating Junction Temperature Range	0 to 150	°C
T_{stg}	Storage Temperature Range ^(*)	-65 to 150	°C
T_{LEAD}	Lead Temperature (Soldering) 10 Sec.	260	°C

(*) Storage temperatures > 125°C are only acceptable if the Dual Regulator is soldered to a PCBA.

Absolute Maximum Ratings are those beyond which damage to the device may occur. Functional operation under these condition is not implied.

Table 3: Recommended Operating Conditions

Symbol	Parameter	Value	Unit
V_I	Input Voltage	4.5 to 7	V
ΔV_I	Input Voltage Ripple	± 0.15	V
t_{RISE}	Input Voltage Rise Time (from 10% to 90%)	≥ 1	μsec
t_{FALL}	Input Voltage Fall Time (from 10% to 90%)	≥ 1	μsec

Table 4: Thermal Data

Symbol	Parameter	SPAK	DFN	Unit
$R_{thj-case}$	Thermal Resistance Junction-case	2	2	°C/W
$R_{thj-amb}$	Thermal Resistance Junction-ambient	26	36	°C/W

Figure 3: Pin Connection (top view for SPAK, top through view for DFN8)

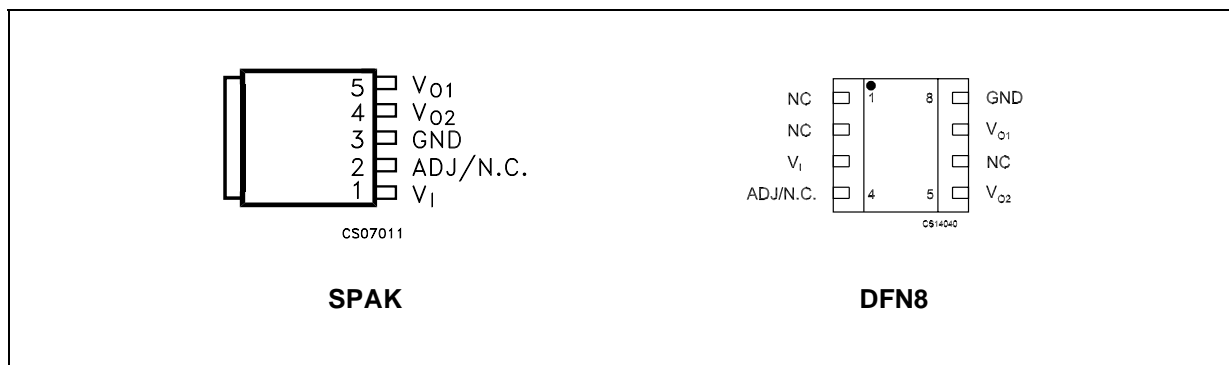

Table 5: Pin Description

SPAK	DFN	Symbol	Name and Function
1	3	V_I	Bypass with a 4.7 μF capacitor to GND
2	4	ADJ/N.C.	Resistor divider connection/Not Connected
3	8	GND	Ground
4	5	V_{O2}	Adjustable output voltage: bypass with a 4.7 μF capacitor to GND
5	7	V_{O1}	Fixed output voltage: bypass with a 4.7 μF capacitor to GND
	1, 2, 6	NC	Not Connected

Figure 4: Application Circuit Of Fixed/fixed Version

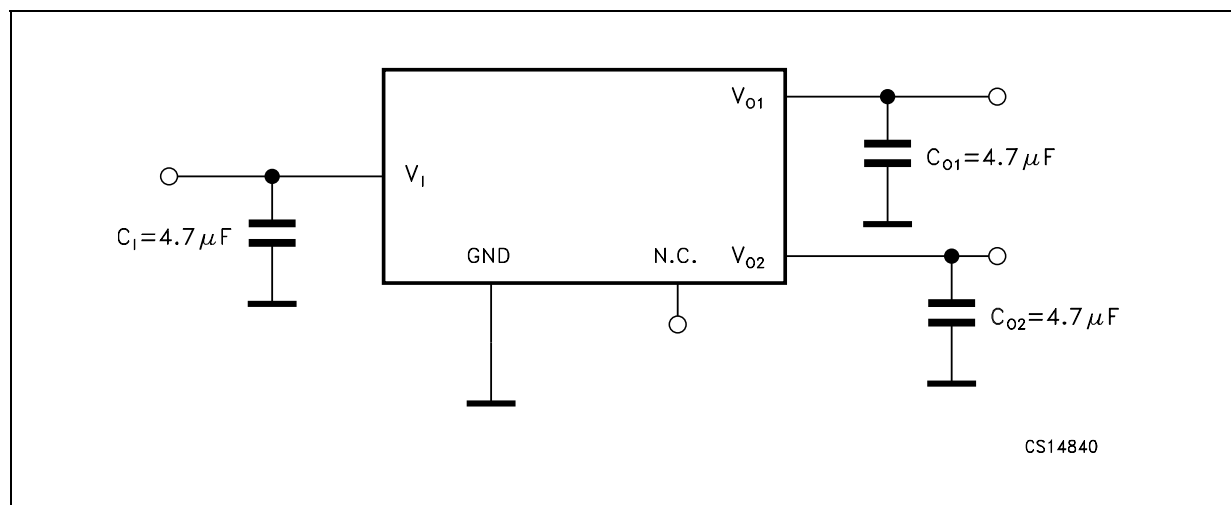
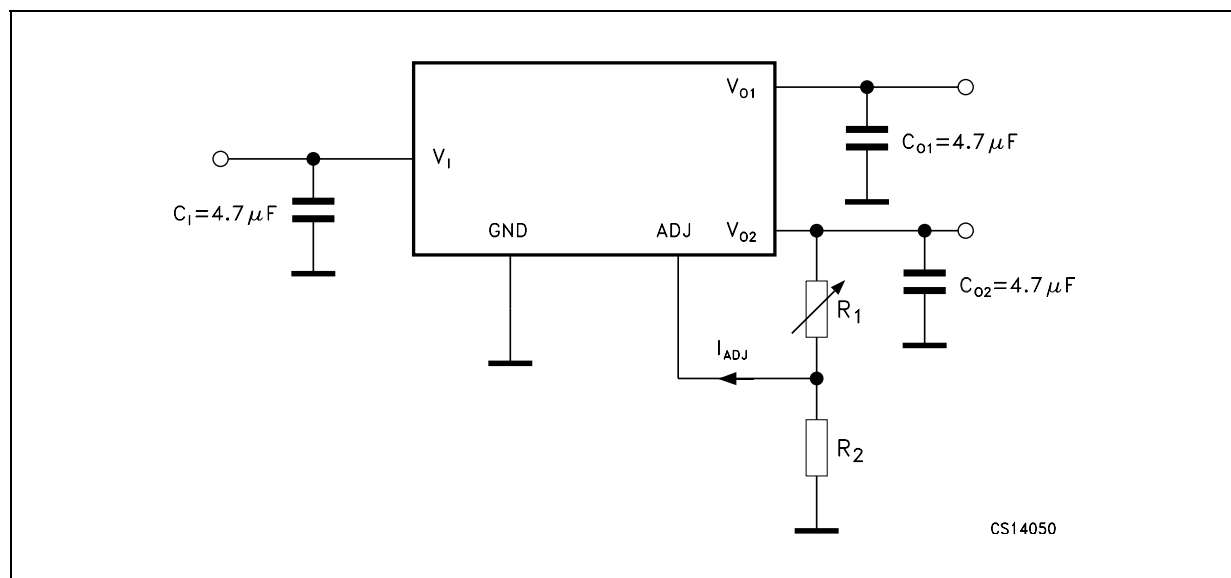

Figure 5: Application Circuit Of Fixed/adj Version



NOTE: The regulator is designed to be stable with either tantalum or ceramic capacitors on the input and outputs. The expected values of the input and output X7R ceramic capacitors are from 4.7μF to 22μF with 4.7μF typical. The input capacitor must be connected within 0.5 inches of the V_1 terminal. The output capacitors must also be connected within 0.5 inches of output pins V_{O1} and V_{O2} . There is no upper limit to the size of the input capacitor (for more details see the Application Hints section).

NOTE: In the Fixed/ADJ version, the adjustable output voltage V_{O2} is designed to support output voltages from 1.25V to $V_1 - V_{DROP}$. The adjustable output voltage V_{O2} is set by a resistor divider connected between V_{O2} (pin4) and Ground (pin3) with its centre tap connected to V_{O2} ADJ (pin2). The voltage divider resistors are: R_1 connected to V_{O2} and V_{O2} ADJ and R_2 connected to V_{O2} ADJ and GND. V_{O2} is determined by V_{REF} , R_1 , R_2 , and I_{ADJ} as follows (for more details see the Application Hints section):

$$V_{O2} = V_{REF} (1 + R_1/R_2) + I_{ADJ}R_1$$

Table 6: Output1 And Output2 Dual Specification ($I_O = 10\text{mA}$ to 1A , $T_J = 0$ to 125°C , $V_I = 4.5\text{V}$ to 7V , $C_I = 4.7\mu\text{F}$, $C_{O1} = C_{O2} = 4.7\mu\text{F}$, otherwise specified)

Symbol	Parameter	Test Conditions	Min.	Typ.	Max.	Unit
I_{GND}	Quiescent Current (Fixed/ADJ)	$V_I \leq 7\text{V}$ $I_{\text{OUT}1,2} = 5\text{mA}$ to 1A			5	mA
I_{GND}	Quiescent Current (Fixed/Fixed)	$V_I \leq 7\text{V}$ $I_{\text{OUT}1,2} = 5\text{mA}$ to 1A			7	mA
I_{ST}	Total Current Limit $I_{O1} + I_{O2}$		2			A
T_{SHDN}	Thermal Shutdown			175		$^\circ\text{C}$
DT_{SHDN}	Thermal Shutdown Hysteresis			5		$^\circ\text{C}$

Table 7: Electrical Characteristics Of Fixed Output 1.5V ($I_O = 10\text{mA}$ to 1A , $T_J = 0$ to 125°C , $V_I = 4.5\text{V}$ to 7V , $C_I = 4.7\mu\text{F}$, $C_{O1} = C_{O2} = 4.7\mu\text{F}$, otherwise specified)

Symbol	Parameter	Test Conditions	Min.	Typ.	Max.	Unit
V_O	Output Voltage 1.5V	$I_O = 5\text{mA}$ to 1A , $V_I = 4.75$ to 5.25V $T = 25^\circ\text{C}$	1.47	1.5	1.53	V
V_O	Output Voltage 1.5V	$I_O = 5\text{mA}$ to 1A , $V_I = 4.75$ to 5.25V	1.455	1.5	1.545	V
ΔV_O	Line Regulation	$V_I = 4.75$ to 5.25V , $I_O = 5\text{mA}$ to 1A			15	mV
ΔV_O	Load Regulation	$V_I = 4.75\text{V}$, $I_O = 10\text{mA}$ to 1A			12	mV
V_D	Dropout Voltage $\Delta V_O = -1\%$	$I_O = 1\text{A}$			1.3	V
I_S	Current Limit	$V_I = 5.5\text{V}$	1			A
I_{OMIN}	Min. Output Current for regulation				0	mA
e_N	RMS Output Noise ⁽¹⁾⁽⁴⁾	$T = 25^\circ\text{C}$		0.003		%
SVR	Supply Voltage Rejection ⁽²⁾⁽⁴⁾	$V_I = 5\text{V}$	60			dB
$\Delta V_O/\Delta I_O$	Transient Response Change of V_O with step load change ⁽³⁾⁽⁴⁾	$V_I = 5\text{V}$, $I_O = 1\text{mA}$ to 1A , $t_r \geq 1\mu\text{s}$			$10^{(5)}$	%
		$V_I = 5\text{V}$, $I_O = 1\text{A}$ to 1mA , $t_r \geq 1\mu\text{s}$			$10^{(5)}$	
$\Delta V_{O1}/\Delta V_I$	Transient Response Change of $V_{\text{OUT}1}$ with application of V_I ⁽³⁾⁽⁴⁾	0 to 5V step input, $I_O = 1\text{mA}$ to 1A , $t_r \geq 1\mu\text{s}$			$10^{(5)}$	%
$\Delta V_O/\Delta I_O$	Transient Response Short Circuit Removal Response ⁽³⁾⁽⁴⁾	$V_I = 5\text{V}$, $I_O = \text{short}$ to $I_O = 10\text{mA}$			$20^{(5)}$	%
T_R	Thermal Regulation ⁽⁴⁾	$I_O = 1\text{A}$, $t_{\text{PULSE}} = 30\text{ms}$		0.1		%/W
S	Temperature Stability ⁽⁴⁾			0.5		%
S	Long Term Stability ⁽⁴⁾ (1000Hrs)	$T_J = 125^\circ\text{C}$		0.3		%

NOTE 1: Bandwidth of 10 Hz to 10KHz.

NOTE 2: 120Hz input ripple.

NOTE 3: $C_I = 20\mu\text{F}$, C_1 and $C_{O2} = 10\mu\text{F}$. C_I , C_{O1} and C_{O2} are all X7R ceramic capacitors.

NOTE 4: Guaranteed by design, not tested in production.

NOTE 5: % undershoot or overshoot of V_O .

Table 8: Electrical Characteristics Of Fixed Output 1.8V ($I_O = 10\text{mA}$ to 1A , $T_J = 0$ to 125°C , $V_I = 4.5\text{V}$ to 7V , $C_I = 4.7\mu\text{F}$, $C_{O1} = C_{O2} = 4.7\mu\text{F}$, otherwise specified)

Symbol	Parameter	Test Conditions	Min.	Typ.	Max.	Unit
V_O	Output Voltage 1.8V	$I_O = 5\text{mA}$ to 1A , $V_I = 4.75$ to 5.25V $T = 25^\circ\text{C}$	1.764	1.8	1.836	V
V_O	Output Voltage 1.8V	$I_O = 5\text{mA}$ to 1A , $V_I = 4.75$ to 5.25V	1.746	1.8	1.854	V
ΔV_O	Line Regulation	$V_I = 4.75$ to 5.25V , $I_O = 5\text{mA}$ to 1A			15	mV
ΔV_O	Load Regulation	$V_I = 4.75\text{V}$, $I_O = 10\text{mA}$ to 1A			12	mV
V_D	Dropout Voltage $\Delta V_O = -1\%$	$I_O = 1\text{A}$			1.3	V
I_S	Current Limit	$V_I = 5.5\text{V}$	1			A
$I_{O\text{MIN}}$	Min. Output Current for regulation				0	mA
e_N	RMS Output Noise ⁽¹⁾⁽⁴⁾	$T = 25^\circ\text{C}$		0.003		%
SVR	Supply Voltage Rejection ⁽²⁾⁽⁴⁾	$V_I = 5\text{V}$	60			dB
$\Delta V_O/\Delta I_O$	Transient Response Change of V_O with step load change ⁽³⁾⁽⁴⁾	$V_I = 5\text{V}$, $I_O = 1\text{mA}$ to 1A , $t_r \geq 1\mu\text{s}$			$10^{(5)}$	%
		$V_I = 5\text{V}$, $I_O = 1\text{A}$ to 1mA , $t_r \geq 1\mu\text{s}$			$10^{(5)}$	
$\Delta V_{O1}/\Delta V_I$	Transient Response Change of V_{OUT1} with application of V_I ⁽³⁾⁽⁴⁾	0 to 5V step input, $I_O = 1\text{mA}$ to 1A , $t_r \geq 1\mu\text{s}$			$10^{(5)}$	%
$\Delta V_O/\Delta I_O$	Transient Response Short Circuit Removal Response ⁽³⁾⁽⁴⁾	$V_I = 5\text{V}$, $I_O = \text{short}$ to $I_O = 10\text{mA}$			$20^{(5)}$	%
T_R	Thermal Regulation ⁽⁴⁾	$I_O = 1\text{A}$, $t_{\text{PULSE}} = 30\text{ms}$		0.1		%/W
S	Temperature Stability ⁽⁴⁾			0.5		%
S	Long Term Stability ⁽⁴⁾ (1000Hrs)	$T_J = 125^\circ\text{C}$		0.3		%

NOTE 1: Bandwidth of 10 Hz to 10KHz.

NOTE 2: 120Hz input ripple.

NOTE 3: $C_I = 20\mu\text{F}$, C_1 and $C_{O2} = 10\mu\text{F}$. C_I , C_{O1} and C_{O2} are all X7R ceramic capacitors.

NOTE 4: Guaranteed by design, not tested in production.

NOTE 5: % undershoot or overshoot of V_O .

Table 9: Electrical Characteristics Of Fixed Output 2.5V ($I_O = 10\text{mA}$ to 1A , $T_J = 0$ to 125°C , $V_I = 4.5\text{V}$ to 7V , $C_I = 4.7\mu\text{F}$, $C_{O1} = C_{O2} = 4.7\mu\text{F}$, otherwise specified)

Symbol	Parameter	Test Conditions	Min.	Typ.	Max.	Unit
V_O	Output Voltage 2.5V	$I_O = 5\text{mA}$ to 1A , $V_I = 4.75$ to 5.25V $T = 25^\circ\text{C}$	2.45	2.5	2.55	V
V_O	Output Voltage 2.5V	$I_O = 5\text{mA}$ to 1A , $V_I = 4.75$ to 5.25V	2.425	2.5	2.575	V
ΔV_O	Line Regulation	$V_I = 4.75$ to 5.25V , $I_O = 5\text{mA}$ to 1A			15	mV
ΔV_O	Load Regulation	$V_I = 4.75\text{V}$, $I_O = 10\text{mA}$ to 1A			12	mV
V_D	Dropout Voltage $\Delta V_O = -1\%$	$I_O = 1\text{A}$			1.3	V
I_S	Current Limit	$V_I = 5.5\text{V}$	1			A
$I_{O\text{MIN}}$	Min. Output Current for regulation				0	mA
e_N	RMS Output Noise ⁽¹⁾⁽⁴⁾	$T = 25^\circ\text{C}$		0.003		%
SVR	Supply Voltage Rejection ⁽²⁾⁽⁴⁾	$V_I = 5\text{V}$	60			dB
$\Delta V_O/\Delta I_O$	Transient Response Change of V_O with step load change ⁽³⁾⁽⁴⁾	$V_I = 5\text{V}$, $I_O = 1\text{mA}$ to 1A , $t_r \geq 1\mu\text{s}$			$10^{(5)}$	%
		$V_I = 5\text{V}$, $I_O = 1\text{A}$ to 1mA , $t_r \geq 1\mu\text{s}$			$10^{(5)}$	
$\Delta V_{O1}/\Delta V_I$	Transient Response Change of V_{OUT1} with application of V_I ⁽³⁾⁽⁴⁾	0 to 5V step input, $I_O = 1\text{mA}$ to 1A , $t_r \geq 1\mu\text{s}$			$10^{(5)}$	%
$\Delta V_O/\Delta I_O$	Transient Response Short Circuit Removal Response ⁽³⁾⁽⁴⁾	$V_I = 5\text{V}$, $I_O = \text{short}$ to $I_O = 10\text{mA}$			$20^{(5)}$	%
T_R	Thermal Regulation ⁽⁴⁾	$I_O = 1\text{A}$, $t_{\text{PULSE}} = 30\text{ms}$		0.1		%/W
S	Temperature Stability ⁽⁴⁾			0.5		%
S	Long Term Stability ⁽⁴⁾ (1000Hrs)	$T_J = 125^\circ\text{C}$		0.3		%

NOTE 1: Bandwidth of 10 Hz to 10KHz.

NOTE 2: 120Hz input ripple.

NOTE 3: $C_I = 20\mu\text{F}$, C_1 and $C_{O2} = 10\mu\text{F}$. C_I , C_{O1} and C_{O2} are all X7R ceramic capacitors.

NOTE 4: Guaranteed by design, not tested in production.

NOTE 5: % undershoot or overshoot of V_O .

Table 10: Electrical Characteristics Of Fixed Output 2.8V ($I_O = 10\text{mA}$ to 1A , $T_J = 0$ to 125°C , $V_I = 4.5\text{V}$ to 7V , $C_I = 4.7\mu\text{F}$, $C_{O1} = C_{O2} = 4.7\mu\text{F}$, otherwise specified)

Symbol	Parameter	Test Conditions	Min.	Typ.	Max.	Unit
V_O	Output Voltage 2.8V	$I_O = 5\text{mA}$ to 1A , $V_I = 4.75$ to 5.25V $T = 25^\circ\text{C}$	2.744	2.8	2.856	V
V_O	Output Voltage 2.8V	$I_O = 5\text{mA}$ to 1A , $V_I = 4.75$ to 5.25V	2.716	2.8	2.884	V
ΔV_O	Line Regulation	$V_I = 4.75$ to 5.25V , $I_O = 5\text{mA}$ to 1A			15	mV
ΔV_O	Load Regulation	$V_I = 4.75\text{V}$, $I_O = 10\text{mA}$ to 1A			12	mV
V_D	Dropout Voltage $\Delta V_O = -1\%$	$I_O = 1\text{A}$			1.3	V
I_S	Current Limit	$V_I = 5.5\text{V}$	1			A
$I_{O\text{MIN}}$	Min. Output Current for regulation				0	mA
e_N	RMS Output Noise ⁽¹⁾⁽⁴⁾	$T = 25^\circ\text{C}$		0.003		%
SVR	Supply Voltage Rejection ⁽²⁾⁽⁴⁾	$V_I = 5\text{V}$	60			dB
$\Delta V_O/\Delta I_O$	Transient Response Change of V_O with step load change ⁽³⁾⁽⁴⁾	$V_I = 5\text{V}$, $I_O = 1\text{mA}$ to 1A , $t_r \geq 1\mu\text{s}$			$10^{(5)}$	%
		$V_I = 5\text{V}$, $I_O = 1\text{A}$ to 1mA , $t_r \geq 1\mu\text{s}$			$10^{(5)}$	
$\Delta V_{O1}/\Delta V_I$	Transient Response Change of V_{OUT1} with application of V_I ⁽³⁾⁽⁴⁾	0 to 5V step input, $I_O = 1\text{mA}$ to 1A , $t_r \geq 1\mu\text{s}$			$10^{(5)}$	%
$\Delta V_O/\Delta I_O$	Transient Response Short Circuit Removal Response ⁽³⁾⁽⁴⁾	$V_I = 5\text{V}$, $I_O = \text{short}$ to $I_O = 10\text{mA}$			$20^{(5)}$	%
T_R	Thermal Regulation ⁽⁴⁾	$I_O = 1\text{A}$, $t_{\text{PULSE}} = 30\text{ms}$		0.1		%/W
S	Temperature Stability ⁽⁴⁾			0.5		%
S	Long Term Stability ⁽⁴⁾ (1000Hrs)	$T_J = 125^\circ\text{C}$		0.3		%

NOTE 1: Bandwidth of 10 Hz to 10KHz.

NOTE 2: 120Hz input ripple.

NOTE 3: $C_I = 20\mu\text{F}$, C_1 and $C_{O2} = 10\mu\text{F}$. C_I , C_{O1} and C_{O2} are all X7R ceramic capacitors.

NOTE 4: Guaranteed by design, not tested in production.

NOTE 5: % undershoot or overshoot of V_O .

Table 11: Electrical Characteristics Of Fixed Output 3.0V ($I_O = 10\text{mA}$ to 1A , $T_J = 0$ to 125°C , $V_I = 4.5\text{V}$ to 7V , $C_I = 4.7\mu\text{F}$, $C_{O1} = C_{O2} = 4.7\mu\text{F}$, otherwise specified)

Symbol	Parameter	Test Conditions	Min.	Typ.	Max.	Unit
V_O	Output Voltage 3.0V	$I_O = 5\text{mA}$ to 1A , $V_I = 4.75$ to 5.25V $T = 25^\circ\text{C}$	2.94	3.0	3.06	V
V_O	Output Voltage 3.0V	$I_O = 5\text{mA}$ to 1A , $V_I = 4.75$ to 5.25V	2.91	3.0	3.09	V
ΔV_O	Line Regulation	$V_I = 4.75$ to 5.25V , $I_O = 5\text{mA}$ to 1A			15	mV
ΔV_O	Load Regulation	$V_I = 4.75\text{V}$, $I_O = 10\text{mA}$ to 1A			12	mV
V_D	Dropout Voltage $\Delta V_O = -1\%$	$I_O = 1\text{A}$			1.3	V
I_S	Current Limit	$V_I = 5.5\text{V}$	1			A
$I_{O\text{MIN}}$	Min. Output Current for regulation				0	mA
e_N	RMS Output Noise ⁽¹⁾⁽⁴⁾	$T = 25^\circ\text{C}$		0.003		%
SVR	Supply Voltage Rejection ⁽²⁾⁽⁴⁾	$V_I = 5\text{V}$	60			dB
$\Delta V_O/\Delta I_O$	Transient Response Change of V_O with step load change ⁽³⁾⁽⁴⁾	$V_I = 5\text{V}$, $I_O = 1\text{mA}$ to 1A , $t_r \geq 1\mu\text{s}$			$10^{(5)}$	%
		$V_I = 5\text{V}$, $I_O = 1\text{A}$ to 1mA , $t_r \geq 1\mu\text{s}$			$10^{(5)}$	
$\Delta V_{O1}/\Delta V_I$	Transient Response Change of V_{OUT1} with application of V_I ⁽³⁾⁽⁴⁾	0 to 5V step input, $I_O = 1\text{mA}$ to 1A , $t_r \geq 1\mu\text{s}$			$10^{(5)}$	%
$\Delta V_O/\Delta I_O$	Transient Response Short Circuit Removal Response ⁽³⁾⁽⁴⁾	$V_I = 5\text{V}$, $I_O = \text{short}$ to $I_O = 10\text{mA}$			$20^{(5)}$	%
T_R	Thermal Regulation ⁽⁴⁾	$I_O = 1\text{A}$, $t_{\text{PULSE}} = 30\text{ms}$		0.1		%/W
S	Temperature Stability ⁽⁴⁾			0.5		%
S	Long Term Stability ⁽⁴⁾ (1000Hrs)	$T_J = 125^\circ\text{C}$		0.3		%

NOTE 1: Bandwidth of 10 Hz to 10KHz.

NOTE 2: 120Hz input ripple.

NOTE 3: $C_I = 20\mu\text{F}$, C_1 and $C_{O2} = 10\mu\text{F}$. C_I , C_{O1} and C_{O2} are all X7R ceramic capacitors.

NOTE 4: Guaranteed by design, not tested in production.

NOTE 5: % undershoot or overshoot of V_O .

Table 12: Electrical Characteristics Of Fixed Output 3.3V ($I_O = 10\text{mA}$ to 1A , $T_J = 0$ to 125°C , $V_I = 4.5\text{V}$ to 7V , $C_I = 4.7\mu\text{F}$, $C_{O1} = C_{O2} = 4.7\mu\text{F}$, otherwise specified)

Symbol	Parameter	Test Conditions	Min.	Typ.	Max.	Unit
V_O	Output Voltage 3.3V	$I_O = 5\text{mA}$ to 1A , $V_I = 4.75$ to 5.25V $T = 25^\circ\text{C}$	3.234	3.3	3.366	V
V_O	Output Voltage 3.3V	$I_O = 5\text{mA}$ to 1A , $V_I = 4.75$ to 5.25V	3.2	3.3	3.4	V
ΔV_O	Line Regulation	$V_I = 4.75$ to 5.25V , $I_O = 5\text{mA}$ to 1A			15	mV
ΔV_O	Load Regulation	$V_I = 4.75\text{V}$, $I_O = 10\text{mA}$ to 1A			12	mV
V_D	Dropout Voltage $\Delta V_O = -1\%$	$I_O = 1\text{A}$			1.3	V
I_S	Current Limit	$V_I = 5.5\text{V}$	1			A
$I_{O\text{MIN}}$	Min. Output Current for regulation				0	mA
e_N	RMS Output Noise ⁽¹⁾⁽⁴⁾	$T = 25^\circ\text{C}$		0.003		%
SVR	Supply Voltage Rejection ⁽²⁾⁽⁴⁾	$V_I = 5\text{V}$	60			dB
$\Delta V_O/\Delta I_O$	Transient Response Change of V_O with step load change ⁽³⁾⁽⁴⁾	$V_I = 5\text{V}$, $I_O = 1\text{mA}$ to 1A , $t_r \geq 1\mu\text{s}$			$10^{(5)}$	%
		$V_I = 5\text{V}$, $I_O = 1\text{A}$ to 1mA , $t_r \geq 1\mu\text{s}$			$10^{(5)}$	
$\Delta V_{O1}/\Delta V_I$	Transient Response Change of V_{OUT1} with application of V_I ⁽³⁾⁽⁴⁾	0 to 5V step input, $I_O = 1\text{mA}$ to 1A , $t_r \geq 1\mu\text{s}$			$10^{(5)}$	%
$\Delta V_O/\Delta I_O$	Transient Response Short Circuit Removal Response ⁽³⁾⁽⁴⁾	$V_I = 5\text{V}$, $I_O = \text{short}$ to $I_O = 10\text{mA}$			$20^{(5)}$	%
T_R	Thermal Regulation ⁽⁴⁾	$I_O = 1\text{A}$, $t_{\text{PULSE}} = 30\text{ms}$		0.1		%/W
S	Temperature Stability ⁽⁴⁾			0.5		%
S	Long Term Stability ⁽⁴⁾ (1000Hrs)	$T_J = 125^\circ\text{C}$		0.3		%

NOTE 1: Bandwidth of 10 Hz to 10KHz.

NOTE 2: 120Hz input ripple.

NOTE 3: $C_I = 20\mu\text{F}$, C_1 and $C_{O2} = 10\mu\text{F}$. C_I , C_{O1} and C_{O2} are all X7R ceramic capacitors.

NOTE 4: Guaranteed by design, not tested in production.

NOTE 5: % undershoot or overshoot of V_O .

Table 13: Electrical Characteristics Of Adjustable Output ($I_O = 10\text{mA}$ to 1A , $T_J = 0$ to 125°C , $V_I = 4.5\text{V}$ to 7V , $C_I = 4.7\mu\text{F}$, $C_{O1} = C_{O2} = 4.7\mu\text{F}$, otherwise specified)

Symbol	Parameter	Test Conditions	Min.	Typ.	Max.	Unit
V_O	Reference Voltage	$I_O = 5\text{mA}$ to 1A , $V_I = 4.75$ to 5.25V , $T = 25^\circ\text{C}$	1.225	1.25	1.275	V
V_O	Reference Voltage	$I_O = 5\text{mA}$ to 1A , $V_I = 4.75$ to 5.25V	1.212	1.25	1.287	V
ΔV_{O2}	Line Regulation 2	$V_I = 4.75$ to 5.25V , $I_O = 5\text{mA}$ to 1A			0.35	%
ΔV_{O2}	Load Regulation 2	$V_I = 4.75\text{V}$, $I_O = 10\text{mA}$ to 1A			0.4	%
V_D	Dropout Voltage $\Delta V_O = -1\%$	$I_O = 1\text{A}$			1.3	V
I_S	Current Limit	$V_I = 5.5\text{V}$	1			A
I_{ADJ}	Adjustable Current (sinking)				1	μA
$I_{\Delta ADJ}$	Adjustable Current Change	$I_O = 10\text{mA}$ to 1A			200	nA
I_{OMIN}	Min. Output Current for regulation				2	mA
e_N	RMS Output Noise ⁽¹⁾⁽⁴⁾	$T = 25^\circ\text{C}$		0.003		%
SVR	Supply Voltage Rejection ⁽²⁾⁽⁴⁾	$V_I = 5\text{V}$	60			dB
$\Delta V_{O2}/\Delta I_{O2}$	Transient Response Change of V_{O1} with step load change ⁽³⁾⁽⁴⁾	$V_I = 5\text{V}$, $I_O = 1\text{mA}$ to 1A , $t_r \geq 1\mu\text{s}$			$10^{(5)}$	%
		$V_I = 5\text{V}$, $I_O = 1\text{A}$ to 1mA , $t_r \geq 1\mu\text{s}$			$10^{(5)}$	
$\Delta V_{O2}/\Delta V_I$	Transient Response Change of V_{OUT1} with application of V_I ⁽³⁾⁽⁴⁾	0 to 5V step input, $I_O = 1\text{mA}$ to 1A , $t_r \geq 1\mu\text{s}$			$10^{(5)}$	%
$\Delta V_{O2}/\Delta I_{O2}$	Transient Response Short Circuit Removal Response ⁽³⁾⁽⁴⁾	$V_I = 5\text{V}$, $I_O = \text{short}$ to $I_O = 10\text{mA}$			$20^{(5)}$	%
T_R	Thermal Regulation ⁽⁴⁾	$I_O = 1\text{A}$, $t_{PULSE} = 30\text{ms}$		0.1		%/W
S	Temperature Stability ⁽⁴⁾			0.5		%
S	Long Term Stability ⁽⁴⁾ (1000Hrs)	$T_J = 125^\circ\text{C}$		0.3		%

NOTE 1: Bandwidth of 10 Hz to 10KHz.

NOTE 2: 120Hz input ripple.

NOTE 3: $C_I = 20\mu\text{F}$, C_1 and $C_{O2} = 10\mu\text{F}$. C_I , C_{O1} and C_{O2} are all X7R ceramic capacitors.

NOTE 4: Guaranteed by design, not tested in production.

NOTE 5: % undershoot or overshoot of V_O .

APPLICATION HINTS

EXTERNAL CAPACITORS

Like any low-dropout regulator, the ST2L05 requires external capacitors for stability. We suggest soldering both capacitors as close as possible to the relative pins (1, 4 and 5).

INPUT CAPACITOR

An input capacitor, whose value is, at least, $2.2\mu\text{F}$ is required; the amount of the input capacitance can be increased without limit if a good quality tantalum or aluminium capacitor is used. SMD X7R or Y5V ceramic multilayer capacitors could not ensure stability in any condition because of their variable characteristics with Frequency and Temperature; the use of this capacitor is strictly related to the use of the output capacitors. For more details read the "OUTPUT CAPACITOR SECTION". The input capacitor must be located at a distance of not more than 0.5" from the input pin of the device and returned to a clean analog ground.

OUTPUT CAPACITOR

The ST2L05 is designed specifically to work with Ceramic and Tantalum capacitors. Special care must be taken when a Ceramic multilayer capacitor is used. Due to their characteristics they can sometimes have

an ESR value lower than the minimum required by the ST2L05 and their relatively large capacitance can change a lot depending on the ambient temperature. The test results of the ST2L05 stability using multilayer ceramic capacitors show that a minimum value of $2.2\mu\text{F}$ is needed for both regulators. This value can be increased without limit if the input capacitor value is major or equal to $4.7\mu\text{F}$, and up to $10\mu\text{F}$ if the input capacitor is minor than $4.7\mu\text{F}$. Surface-mountable solid tantalum capacitors offer a good combination of small physical size for the capacitance value and ESR in the range needed by the ST2L05. The test results show good stability for both outputs with values of at least $1\mu\text{F}$. The value can be increased without limit for even better performance such as transient response and noise.

IMPORTANT:

The output capacitor must maintain its ESR in the stable region over the full operating temperature to assure stability. More over, capacitor tolerance and variations due to temperature must be considered to assure that the minimum amount of capacitance is provided at all times. For this reason, when a Ceramic multilayer capacitor is used, the better choice for temperature coefficient is the X7R type, which holds the capacitance within $\pm 15\%$. The output capacitor should be located not more than 0.5" from the output pins of the device and returned to a clean analog ground.

ADJUSTABLE REGULATOR

The ST2L05 has a 1.25V reference voltage between the output and the adjust pins (respectively pin 4 and 2). When a resistor R_1 is placed between these two terminals, a constant current flows through R_1 and down to R_2 to set the overall (V_{O2} to GND) output voltage. Minimum load current is 2mA max in all temperature conditions.

Figure 6: Application Circuit

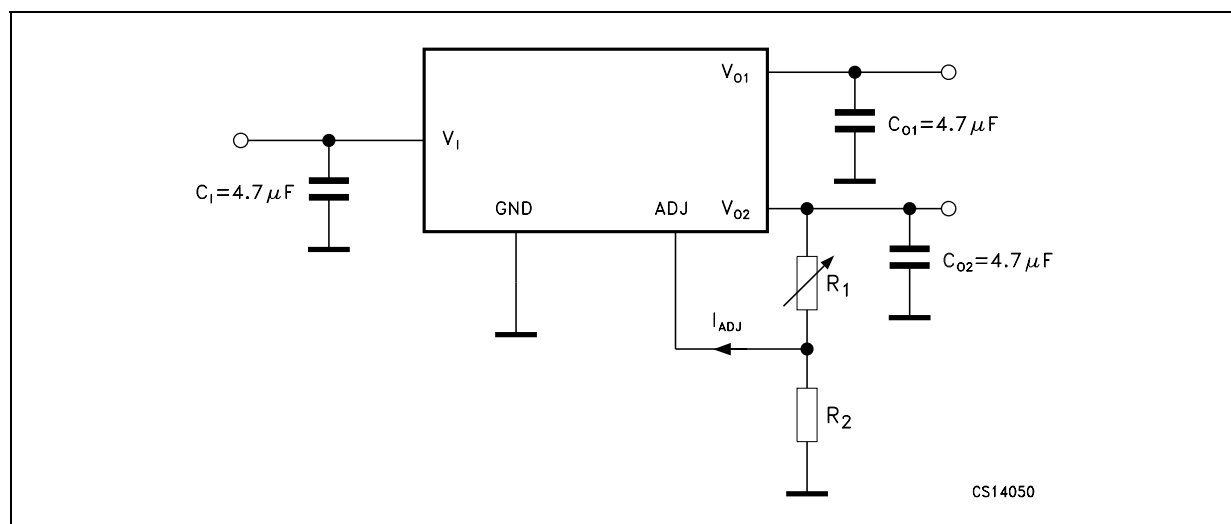

$$V_O = V_{REF}(1+R_1/R_2)+I_{ADJ}R_1$$

I_{ADJ} is very small (typically $35\mu\text{A}$) and constant: in the V_O calculation it can be ignored.

TYPICAL CHARACTERISTICS

Figure 7: Reference Voltage vs Temperature

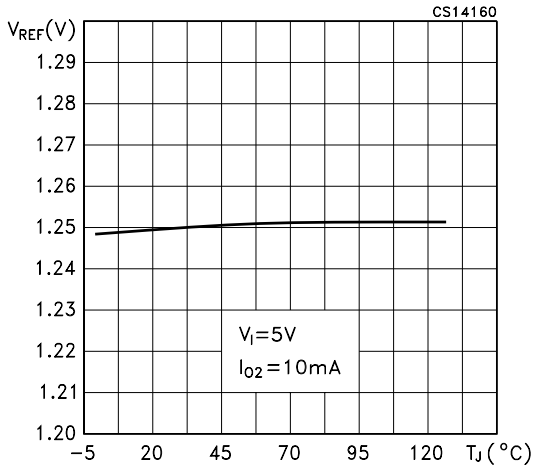

Figure 8: Reference Line Regulation vs Temperature

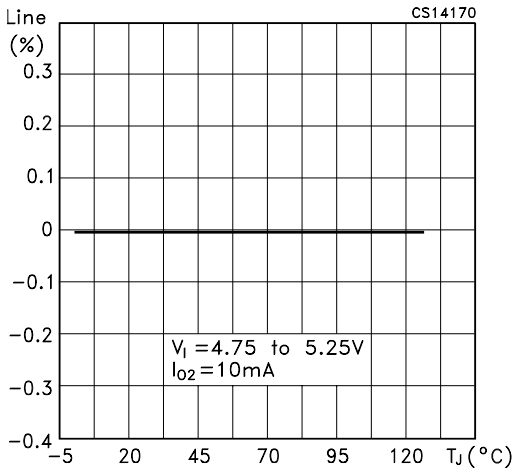

Figure 9: Reference Load Regulation vs Temperature

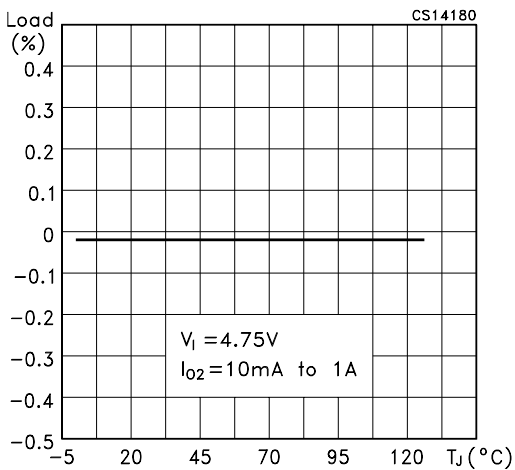

Figure 10: Reference Voltage vs Input Voltage

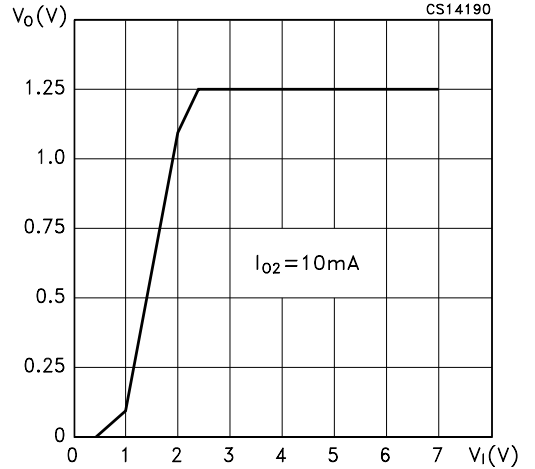

Figure 11: Dropout Voltage vs Temperature (Adjustable Output)

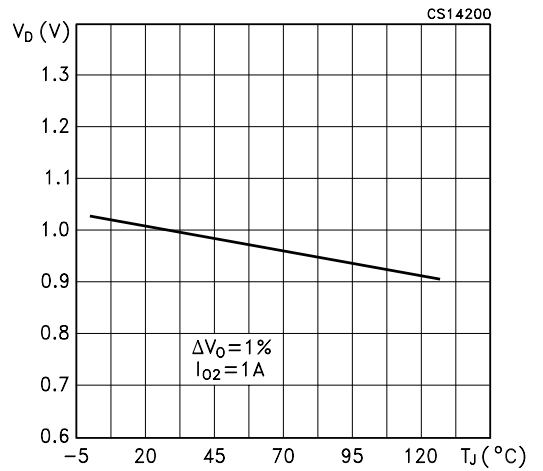

Figure 12: Dropout Voltage vs Input Voltage (Adjustable Output)

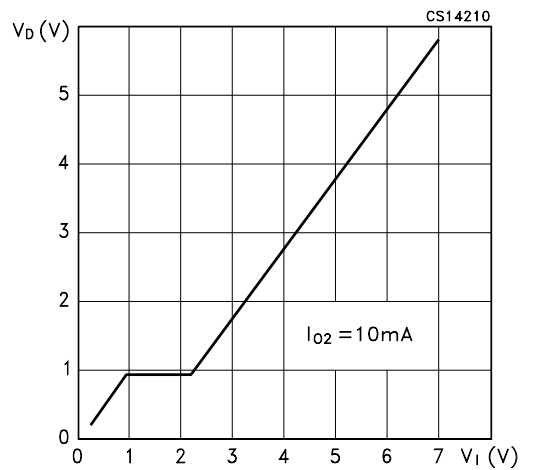

Figure 13: Minimum Load Current vs Temperature (Adjustable Output)

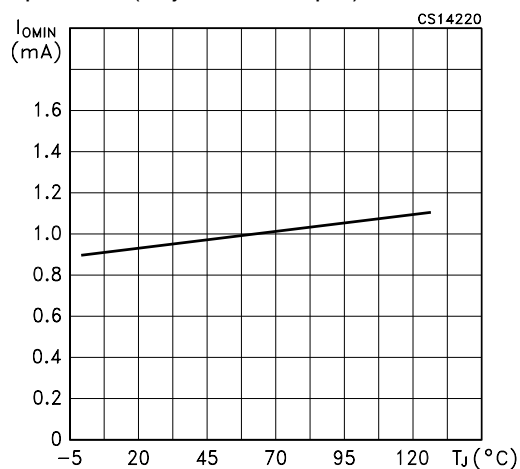

Figure 14: Adjust Pin Current vs Temperature (Adjustable Output)

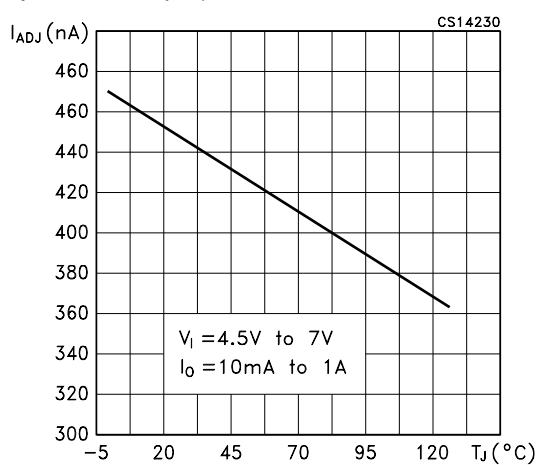

Figure 15: Output Voltage vs Temperature

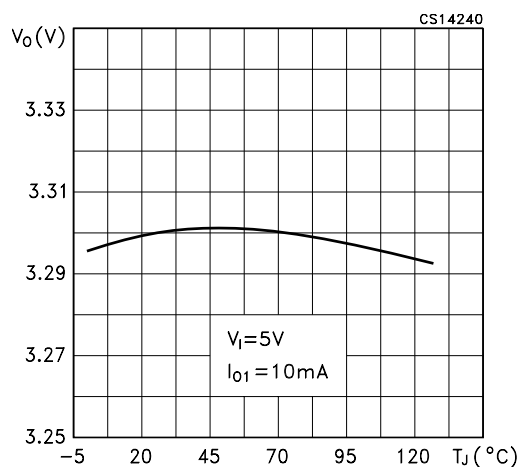

Figure 16: Line Regulation vs Temperature

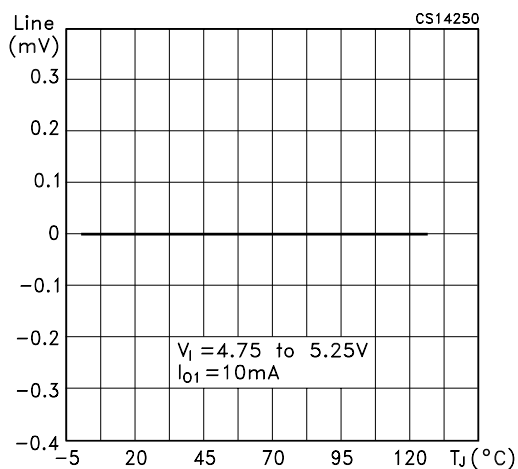

Figure 17: Load Regulation vs Temperature

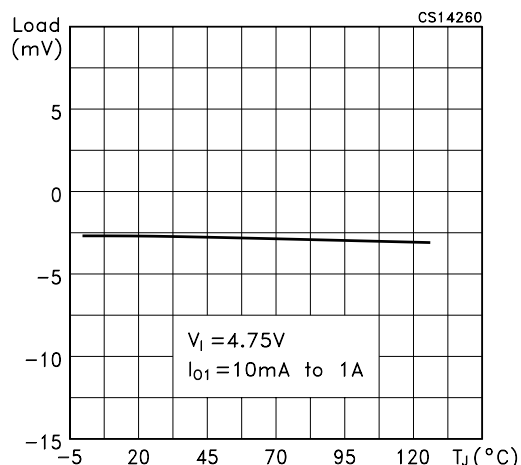

Figure 18: Output Voltage vs Input Voltage

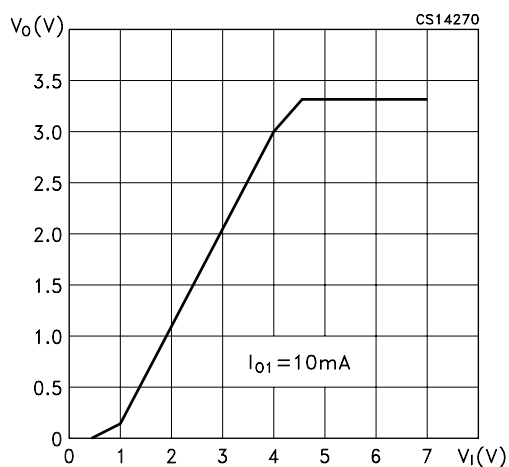

Figure 19: Dropout Voltage vs Temperature (Fixed Output)

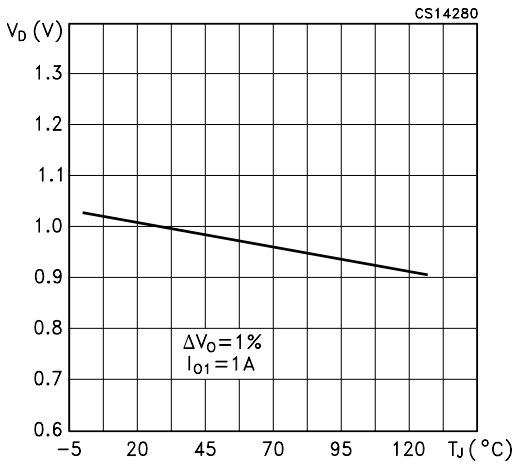

Figure 20: Dropout Voltage vs Input Voltage

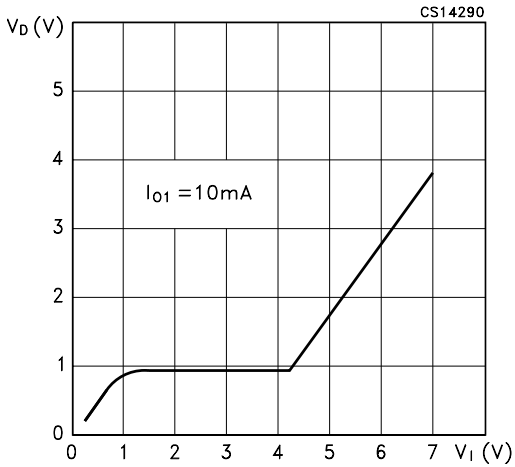

Figure 21: Supply Voltage Rejection vs Temperature

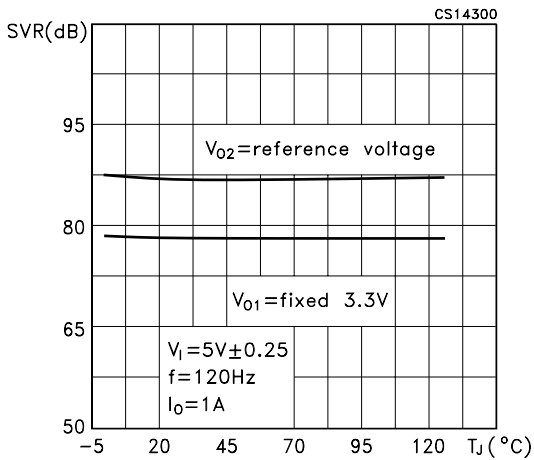

Figure 22: Supply Voltage Rejection vs Frequency

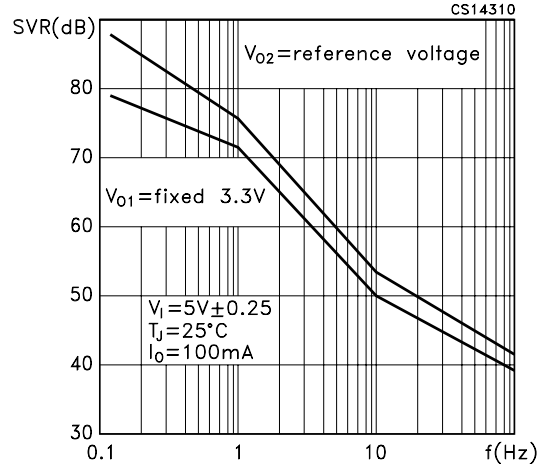

Figure 23: Quiescent Current vs Temperature (Fixed/ADJ Version)

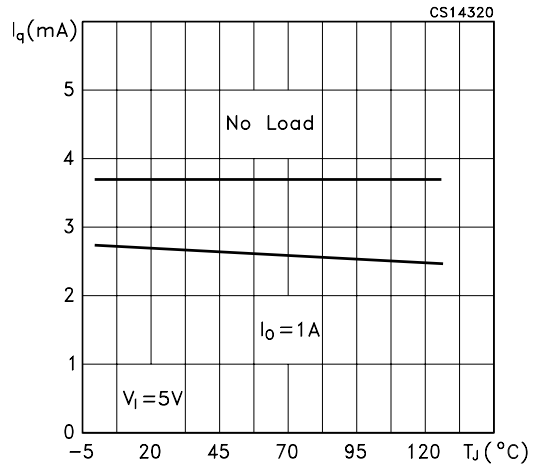

Figure 24: Quiescent Current vs Temperature (Fixed/Fixed Version)

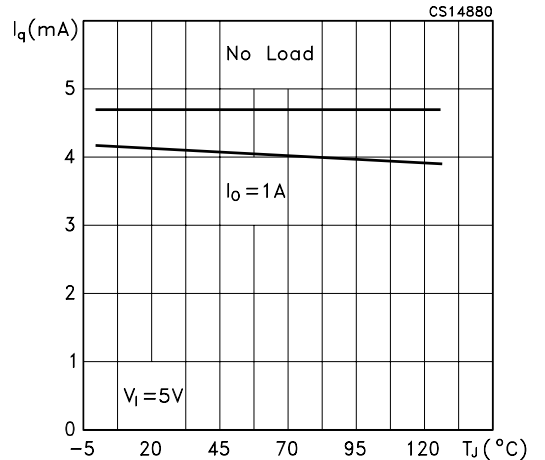
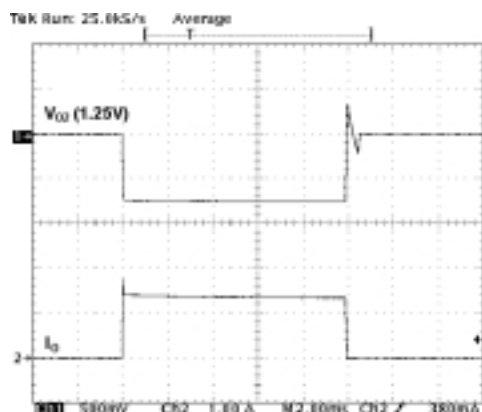
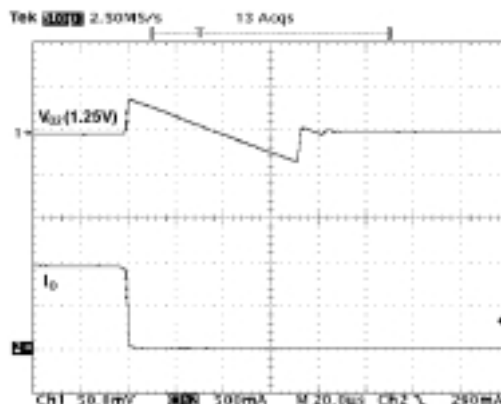
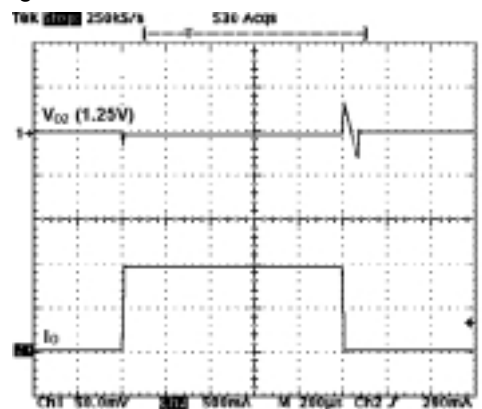

Figure 25: Short Circuit Removal Response

$V_I=5V$, I_O =short circuit to 10mA, $C_O=10\mu F$, $C_I=22\mu F$ all ceramic X5R, $T_J=25^\circ C$

Figure 28: Change of V_O with Step Load Change

$V_I=5V$, $I_O=1A$ to 1mA, $C_O=10\mu F$, $C_I=22\mu F$ all ceramic X5R, $T_J=25^\circ C$, $t_{FALL}=1\mu s$

Figure 26: Change of V_O with Step Load Change

$V_I=5V$, $I_O=1mA$ to 1A, $C_O=10\mu F$, $C_I=22\mu F$ all ceramic X5R, $T_J=25^\circ C$

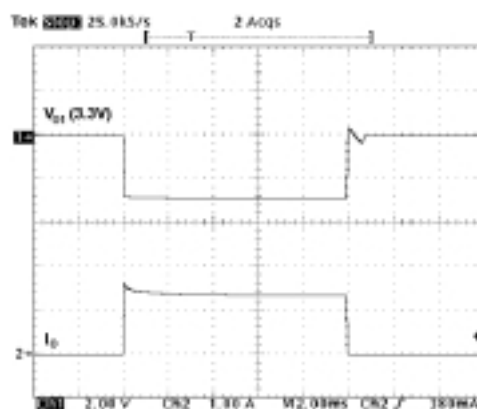
Figure 29: Short Circuit Removal Response

$V_I=5V$, I_O =short circuit to 10mA, $C_O=10\mu F$, $C_I=22\mu F$ all ceramic X5R, $T_J=25^\circ C$

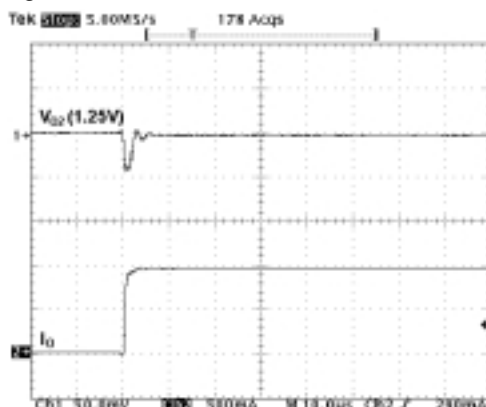
Figure 27: Change of V_O with Step Load Change

$V_I=5V$, $I_O=1mA$ to 1A, $C_O=10\mu F$, $C_I=22\mu F$ all ceramic X5R, $T_J=25^\circ C$, $t_{RISE}=1\mu s$

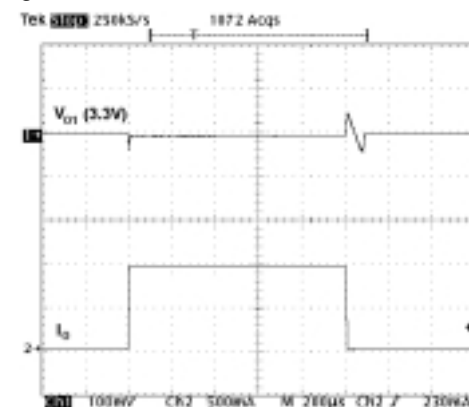
Figure 30: Change of V_O with Step Load Change

$V_I=5V$, $I_O=1mA$ to 1A, $C_O=10\mu F$, $C_I=22\mu F$ all ceramic X5R, $T_J=25^\circ C$, $t_{RISE}=1\mu s$

Figure 31: Change of V_O with Step Load Change

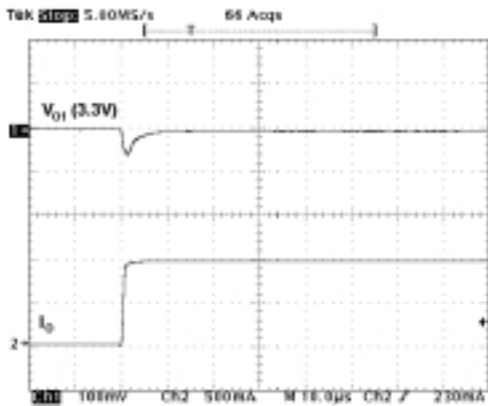

$V_I=5V$, $I_O=1mA$ to $1A$, $C_O=10\mu F$, $C_I=22\mu F$ all ceramic X5R, $T_J=25^\circ C$, $t_{RISE}=t_{FALL}=1\mu s$

Figure 32: Change of V_O with Step Load Change

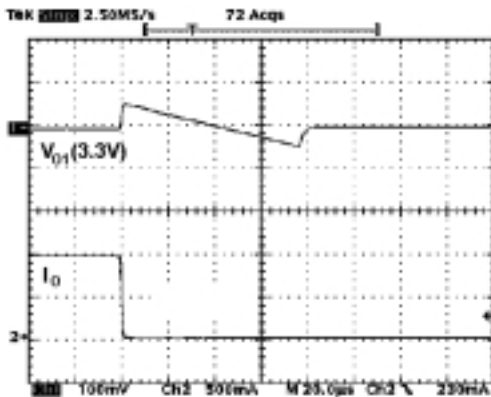

$V_I=5V$, $I_O=1A$ to $1mA$, $C_O=10\mu F$, $C_I=22\mu F$ all ceramic X5R, $T_J=25^\circ C$, $t_{FALL}=1\mu s$

Figure 33: Start-Up Transient

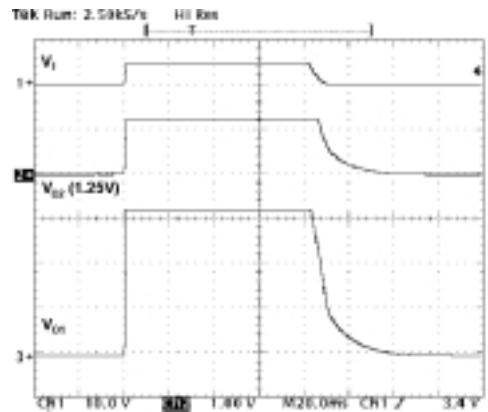

$V_I=0$ to $5V$, $I_O=1mA$, $C_O=10\mu F$, $C_I=22\mu F$ all ceramic X5R, $T_J=25^\circ C$, $t_{RISE} \leq 1\mu s$

Figure 34: Start-Up Transient

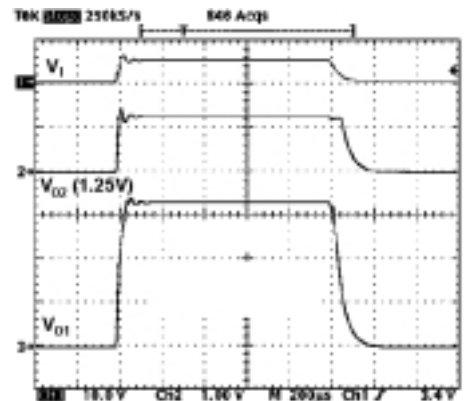

$V_I=0$ to $5V$, $I_O=1A$, $C_O=10\mu F$, $C_I=22\mu F$ all ceramic X5R, $T_J=25^\circ C$, $t_{RISE} \leq 1\mu s$

SPAK-5L MECHANICAL DATA

DIM.	mm.			inch		
	MIN.	TYP	MAX.	MIN.	TYP.	MAX.
A	1.78		2.03	0.070		0.080
A2	0.03		0.13	0.001		0.005
C		0.25			0.010	
C1		0.25			0.010	
D	1.02		1.27	0.040		0.050
D1	7.87		8.13	0.310		0.320
F	0.63		0.79	0.025		0.031
G		1.69			0.067	
G1		6.8			0.268	
H1		5.59			0.220	
H2	9.27		9.52	0.365		0.375
H3	8.89		9.14	0.350		0.360
L	10.41		10.67	0.410		0.420
L1		7.49			0.295	
L2	8.89		9.14	0.350		0.360
M	0.79		1.04	0.031		0.041
N		0.25			0.010	
V	3°		6°	3°		6°

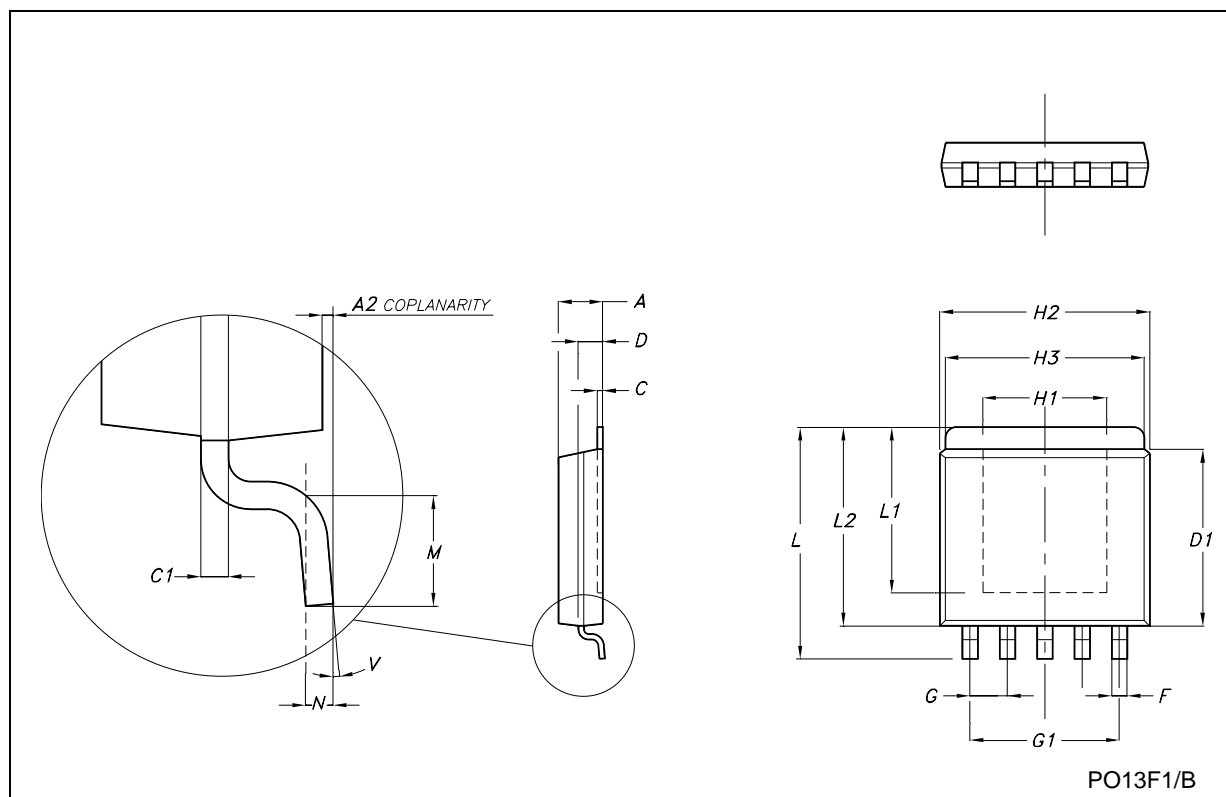

DFN8 (5x6) MECHANICAL DATA

DIM.	mm.			inch		
	MIN.	TYP	MAX.	MIN.	TYP.	MAX.
A	0.80	0.90	1.00	0.032	0.035	0.039
b	0.35	0.40	0.47	0.014	0.016	0.018
D		5.00			0.197	
D2	4.05	4.2	4.30	0.163	0.165	0.167
E		6.00			0.236	
E2	3.40	3.55	3.65	0.134	0.140	0.144
e		1.27			0.049	
L	0.70	0.80	0.90	0.028	0.031	0.035

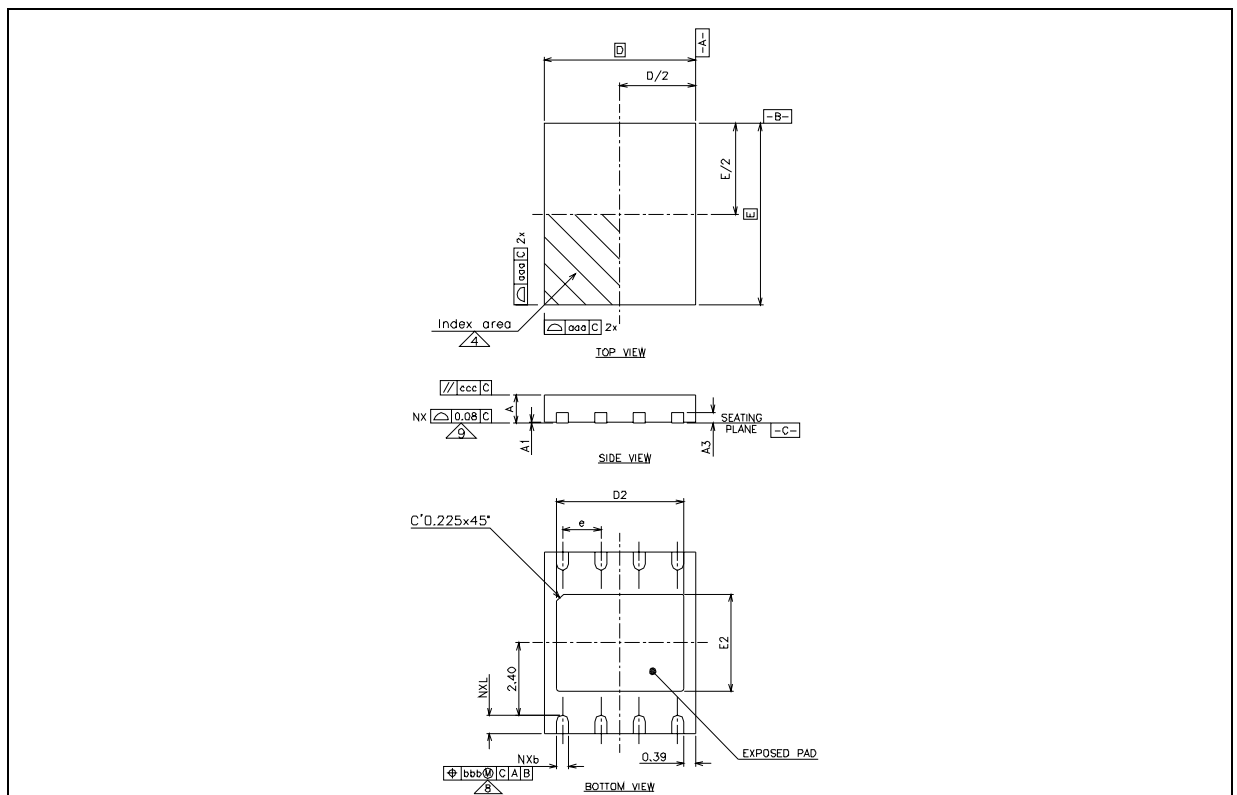

Tape & Reel SPAK-xL MECHANICAL DATA

DIM.	mm.			inch		
	MIN.	TYP	MAX.	MIN.	TYP.	MAX.
A			180			7.086
C	12.8	13.0	13.2	0.504	0.512	0.519
D	20.2			0.795		
N	60			2.362		
T			14.4			0.567
Ao	9.70	9.80	9.90	0.382	0.386	0.390
Bo	10.85	10.95	11.05	0.423	0.427	0.431
Ko	2.30	2.40	2.50	0.090	0.094	0.098
Po	3.9	4.0	4.1	0.153	0.157	0.161
P	11.9	12.0	12.1	0.468	0.472	0.476

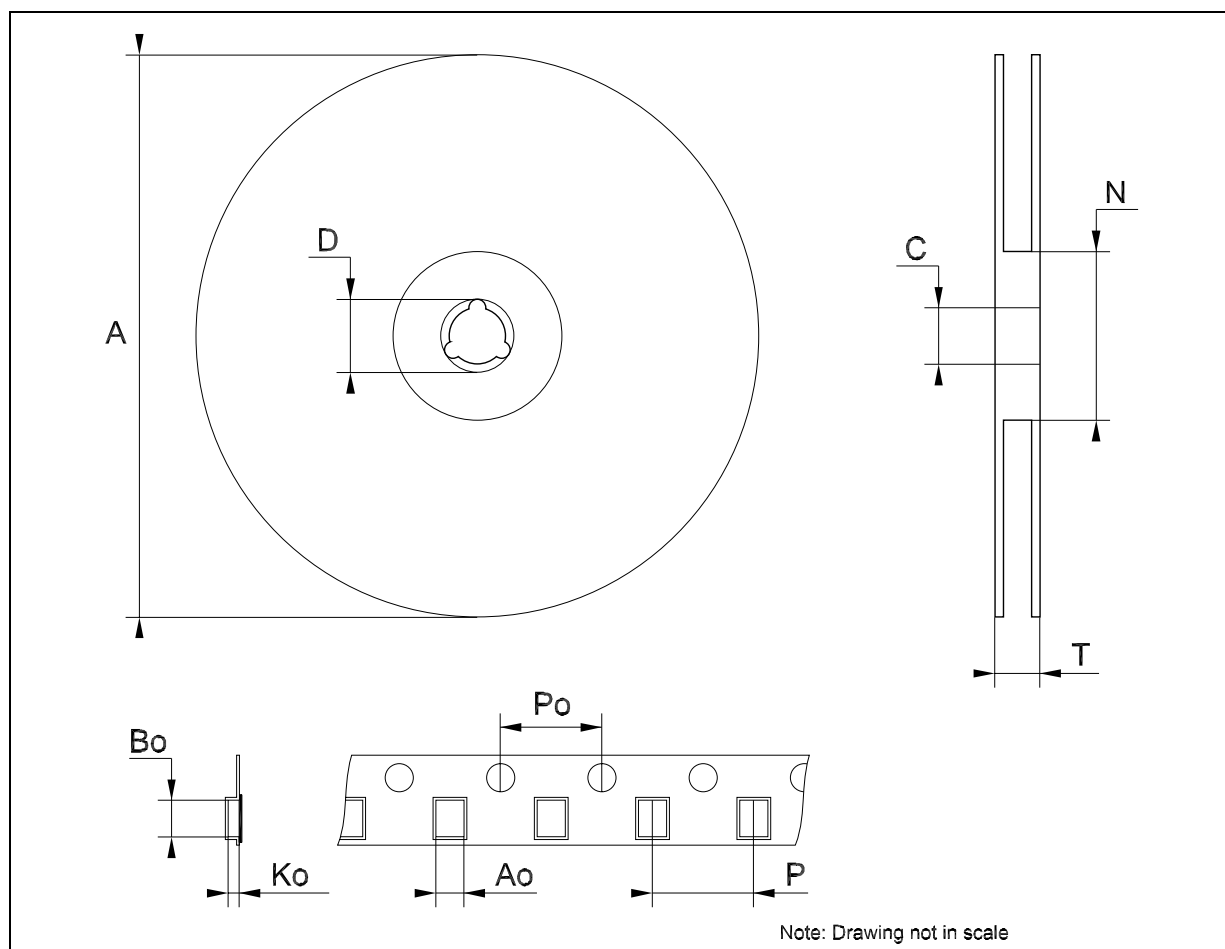

Table 14: Revision History

Date	Revision	Description of Changes
18-Nov-2004	4	Remove PPAK Version.
24-Nov-2004	5	New Mechanical Data Release.
06-Dec-2004	6	New Mechanical Data Release.

Information furnished is believed to be accurate and reliable. However, STMicroelectronics assumes no responsibility for the consequences of use of such information nor for any infringement of patents or other rights of third parties which may result from its use. No license is granted by implication or otherwise under any patent or patent rights of STMicroelectronics. Specifications mentioned in this publication are subject to change without notice. This publication supersedes and replaces all information previously supplied. STMicroelectronics products are not authorized for use as critical components in life support devices or systems without express written approval of STMicroelectronics.

The ST logo is a registered trademark of STMicroelectronics

All other names are the property of their respective owners

© 2004 STMicroelectronics - All Rights Reserved

STMicroelectronics group of companies

Australia - Belgium - Brazil - Canada - China - Czech Republic - Finland - France - Germany - Hong Kong - India - Israel - Italy - Japan - Malaysia - Malta - Morocco - Singapore - Spain - Sweden - Switzerland - United Kingdom - United States of America

www.st.com