



ST26C31

CMOS QUAD TRI-STATE DIFFERENTIAL LINE DRIVER

- TTL INPUT COMPATIBLE
- TYPICAL PROPAGATION DELAY: 6ns
- TYPICAL OUTPUT SKEW: 0.5ns
- OUTPUT WILL NOT LOAD LINE WHEN $V_{CC}=0V$
- MEETS THE REQUIREMENTS OF EIA STANDARD RS-422
- OPERATION FROM SINGLE 5V SUPPLY
- 3-STATE OUTPUTS FOR CONNECTION TO SYSTEM BUSES
- LOW QUIESCENT CURRENT
- AVAILABLE IN SURFACE MOUNT

DESCRIPTION

The ST26C31 is a quad differential line driver designed for digital data transmission over balanced lines and meets all the requirements of EIA standard RS-422 while retaining the low power characteristics of CMOS.

The ST26C31 accepts TTL or CMOS input levels and translates these to RS-422 output levels. This part uses special outputs circuitry common to all four drivers. All outputs are protected against damage due to electrostatic discharge by diode to VCC and ground.

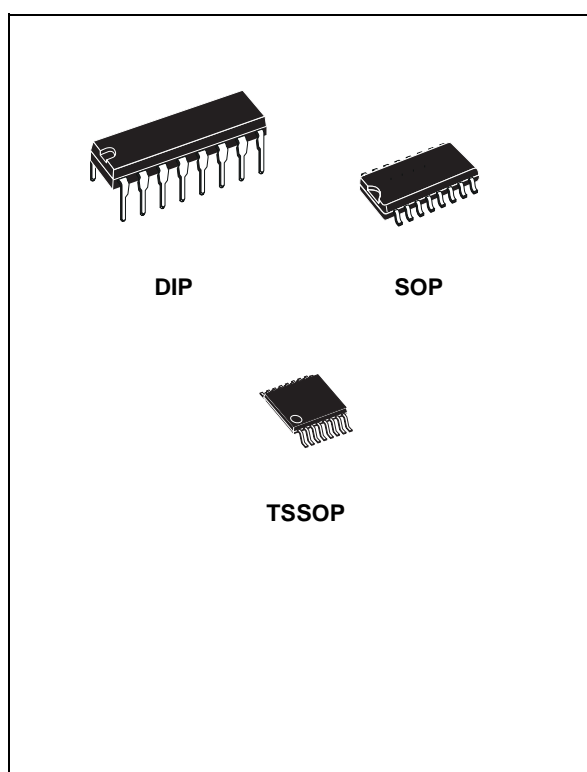

ORDERING CODES

Type	Temperature Range	Package	Comments
ST26C31BN	-40 to 85 °C	DIP-16	25 parts per tube / 40 tube per box
ST26C31BD	-40 to 85 °C	SO-16 (Tube)	50 parts per tube / 20 tube per box
ST26C31BDR	-40 to 85 °C	SO-16 (Tape & Reel)	2500 parts per reel
ST26C31BTR	-40 to 85 °C	TSSOP16 (Tape & Reel)	2500 parts per reel

PIN CONFIGURATION

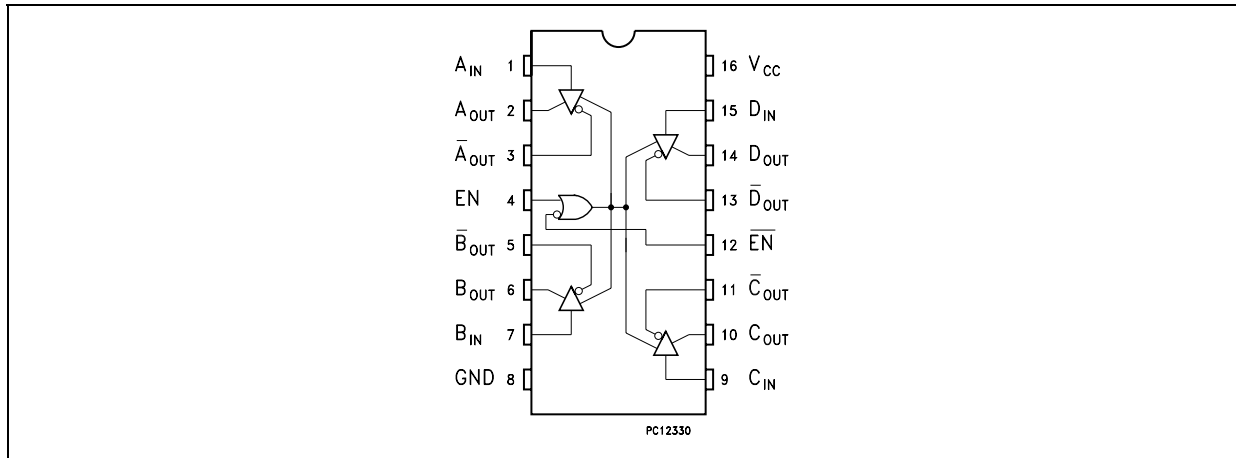

PIN DESCRIPTION

PIN N°	SYMBOL	NAME AND FUNCTION
1	A _{IN}	INPUT A
2	A _{OUT}	Channel A Output
3	A _{OUT}	Channel A Output
4	EN	ENABLE
5	B _{OUT}	Channel B Output
6	B _{OUT}	Channel B Output
7	B _{IN}	INPUT B
8	GND	Ground
9	C _{IN}	INPUT C
10	C _{OUT}	Channel C Output
11	C _{OUT}	Channel C Output
12	EN	ENABLE
13	D _{OUT}	Channel D Output
14	D _{OUT}	Channel D Output
15	D _{IN}	INPUT D
16	V _{CC}	Supply Voltage

TRUTH TABLE

ENABLE	ENABLE	INPUT	OUTPUT	OUTPUT
L	H	X	Z	Z
All other combinations of enable inputs		L	L	H
		H	H	L

L = Low Voltage State
H = High Logic State
X = Don't Care
Z = High Impedance

ABSOLUTE MAXIMUM RATINGS (Note 1, 2)

Symbol	Parameter	Value	Unit
V_{CC}	Supply Voltage	-0.5 to 7	V
V_{IN}	DC Input Voltage	-0.5 to ($V_{CC} + 0.5$)	V
V_{OUT}	DC Output Voltage (High or Low State)	-0.5 to 7	V
I_{IK}	Clamp Diode Current	± 20	mA
I_{OUT}	DC Output Current per Pin	± 150	mA
I_{CC}	DC V_{CC} or GND Current	± 150	mA
T_{stg}	Storage Temperature Range	-65 to +150	°C

Note 1: Absolute Maximum Ratings are those values beyond which the safety of the device cannot be guaranteed. They are not meant to imply that the device should be operated at these limits. The table of electrical characteristics provide conditions for actual device operation.
 Note 2: Unless otherwise specified, all voltage are referenced to ground. All currents into the device pins are positive; all currents out of the device pins are negative.

RECOMMENDED OPERATING CONDITIONS

Symbol	Parameter	Value	Unit
V_{CC}	Supply Voltage	4.5 to 5.5	V
V_{IN}	DC Input Voltage	0 to V_{CC}	V
V_{OUT}	DC Output Voltage (High or Low State)	0 to V_{CC}	V
V_{OUT}	DC Output Voltage ($V_{CC} = 0V$ or High Impedance)	0 to 5	V
T_A	Operating Temperature Range	-40 to +85	°C
t_r, t_f	Maximum Enable Input Rise or Fall Times	500	ns

ELECTRICAL CHARACTERISTICS ($V_{CC} = 5V \pm 10\%$, unless otherwise specified, See Note 1)

Symbol	Parameter	Test Conditions	Value			Unit
			Min.	Typ.	Max.	
V_{IH}	High Level Input Voltage		2			V
V_{IL}	Low Level Input Voltage				0.8	V
V_{OH}	High Level Output Voltage	$V_{IN} = V_{IH}$ or V_{IL} , $I_{OUT} = -20mA$	2.5	3.4		V
V_{OL}	Low Level Output Voltage	$V_{IN} = V_{IH}$ or V_{IL} , $I_{OUT} = +20mA$		0.3	0.5	V
V_T	Differential Output Voltage	$R_L = 100 \Omega$ (Note 2)	2	3.1		V
$V_T - \overline{V_T}$	Difference in Differential Output Voltage	$R_L = 100 \Omega$ (Note 2)			0.4	V
V_{OS}	Common Mode Output Voltage	$R_L = 100 \Omega$ (Note 2)		1.8	3	V
$V_{OS} - \overline{V_{OS}}$	Difference in Common Mode Output Voltage	$R_L = 100 \Omega$ (Note 2)			0.4	V
I_{IN}	Input Current	$V_{IN} = V_{CC}, GND, V_{IH}$ or V_{IL}			± 1	μA
I_{CC}	Quiescent Supply Current (Note 2)	$I_{OUT} = 0 \mu A$		200	500	μA
		$V_{IN} = V_{CC}$ or GND $V_{IN} = 2.4$ or $0.5 V$ (Note 3)		0.8	2	mA
I_{OZ}	3-STATE Output Leakage Current	$V_{OUT} = V_{CC}$ or GND ENABLE = V_{IL} ENABLE = V_{IH}		± 0.5	± 5	μA
I_{SC}	Output Short Circuit Current	$V_{IN} = V_{CC}$ or GND (Notes 2, 4)	-30		-150	mA
I_{OFF}	Power Off Output Leakage Current (Note 2)	$V_{CC} = 0 V$			100	μA
		$V_{OUT} = 6 V$ $V_{OUT} = -0.25 V$			-100	μA

Note 1: Unless otherwise specified, min/max limits apply across the recommended operating temperature range. All typical are given for $V_{CC} = 5V$ and $T_a = 25^\circ C$.

Note 2: See EIA Specification RS422 for exact test conditions.

Note 3: Measured per pin input. All other input at V_{CC} or GND.

Note 4: This is the current sourced when a high output is shorted to ground. Only one output at time should be shorted.

SWITCHING CHARACTERISTICS ($V_{CC} = 5V \pm 10\%$, $t_r = t_f \leq 6ns$, See Note 1)

Symbol	Parameter	Test Conditions	Value			Unit
			Min.	Typ.	Max.	
t_{PLH} t_{PHL}	Propagation Delay Input to Output	S1 Open	2	6	11	ns
Skew	(Note 2)	S1 Open		0.5	2	ns
t_{TLH} t_{THL}	Differential Output Rise and Fall Times	S1 Open		6	10	ns
t_{PZH}	Output Enable Time	S1 Closed		11	19	ns
t_{PZL}	Output Enable Time	S1 Closed		13	21	ns
t_{PHZ}	Output Disable Time (Note 3)	S1 Closed		5	9	ns
t_{PLZ}	Output Disable Time (Note 3)	S1 Closed		7	11	ns
C_{PD}	Power Dissipation Capacitance (Note 4)			50		pF
C_{IN}	Input Capacitance			6		pF

Note 1: Unless otherwise specified, min/max limits apply across the recommended operating temperature range. All typical are given for $V_{CC} = 5V$ and $T_a = 25^\circ C$.

Note 2: Skew is defined as the difference in propagation delays between complementary outputs at the 50% point.

Note 3: Output disable time is the delay from the control input being switched to the output transistors turning off. The actual disable times are less than indicated due to the delay added by RC time constant of the load.

Note 4: CPD determines the no load dynamic power consumption, $P_D = C_{PD} V_{CC}^2 f = I_{CC} V_{CC}$, and the no load dynamic current consumption, $P_D = C_{PD} V_{CC} f + I_{CC}$

Plastic DIP-16 (0.25) MECHANICAL DATA

DIM.	mm.			inch		
	MIN.	TYP	MAX.	MIN.	TYP.	MAX.
a1	0.51			0.020		
B	0.77		1.65	0.030		0.065
b		0.5			0.020	
b1		0.25			0.010	
D			20			0.787
E		8.5			0.335	
e		2.54			0.100	
e3		17.78			0.700	
F			7.1			0.280
I			5.1			0.201
L		3.3			0.130	
Z			1.27			0.050

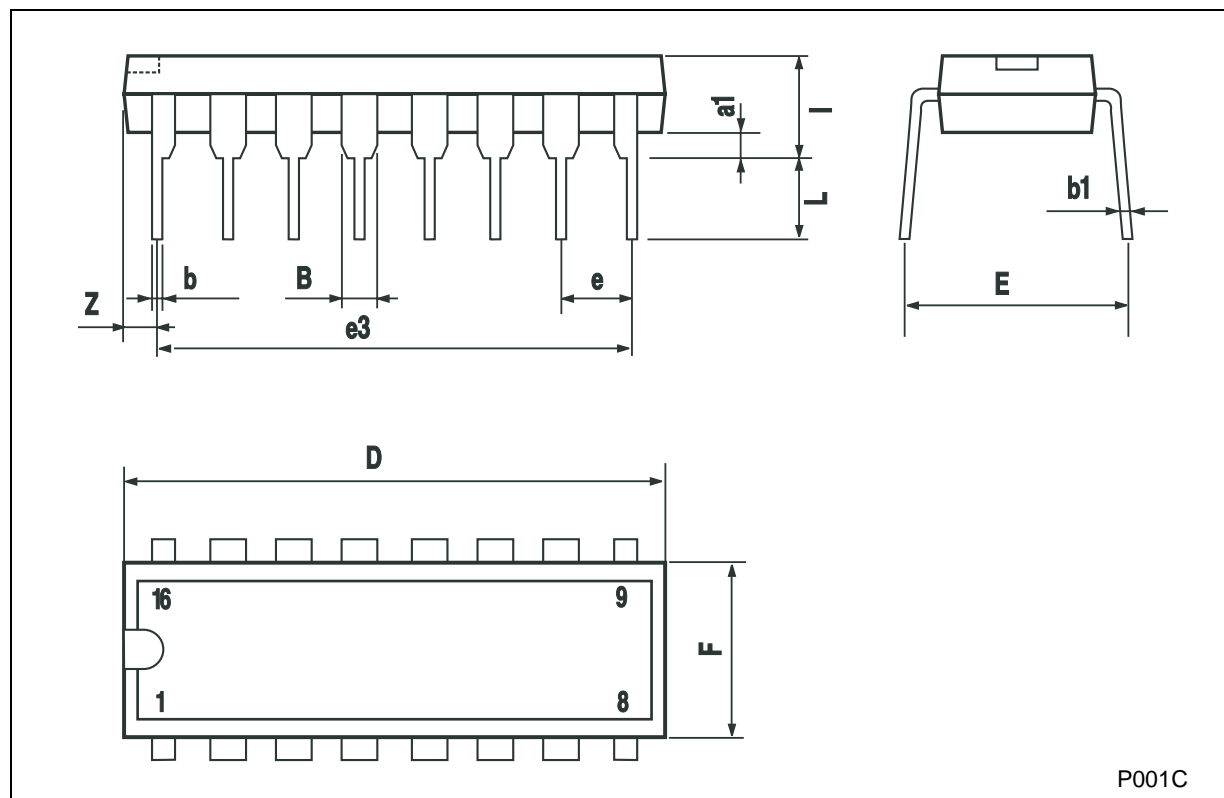

SO-16 MECHANICAL DATA

DIM.	mm.			inch		
	MIN.	TYP.	MAX.	MIN.	TYP.	MAX.
A			1.75			0.068
a1	0.1		0.2	0.004		0.008
a2			1.65			0.064
b	0.35		0.46	0.013		0.018
b1	0.19		0.25	0.007		0.010
C		0.5			0.019	
c1	45° (typ.)					
D	9.8		10	0.385		0.393
E	5.8		6.2	0.228		0.244
e		1.27			0.050	
e3		8.89			0.350	
F	3.8		4.0	0.149		0.157
G	4.6		5.3	0.181		0.208
L	0.5		1.27	0.019		0.050
M			0.62			0.024
S	8			° (max.)		

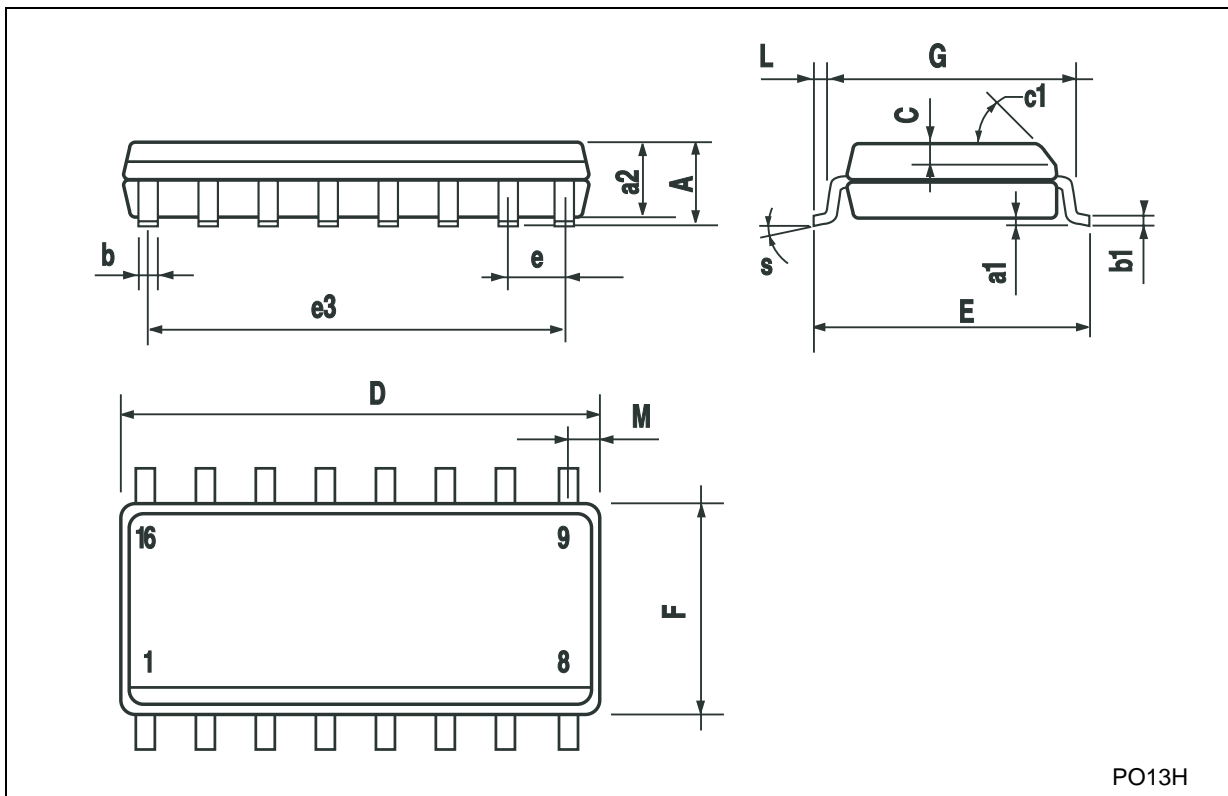

PO13H

TSSOP16 MECHANICAL DATA

DIM.	mm.			inch		
	MIN.	TYP	MAX.	MIN.	TYP.	MAX.
A			1.2			0.047
A1	0.05		0.15	0.002	0.004	0.006
A2	0.8	1	1.05	0.031	0.039	0.041
b	0.19		0.30	0.007		0.012
c	0.09		0.20	0.004		0.0079
D	4.9	5	5.1	0.193	0.197	0.201
E	6.2	6.4	6.6	0.244	0.252	0.260
E1	4.3	4.4	4.48	0.169	0.173	0.176
e		0.65 BSC			0.0256 BSC	
K	0°		8°	0°		8°
L	0.45	0.60	0.75	0.018	0.024	0.030

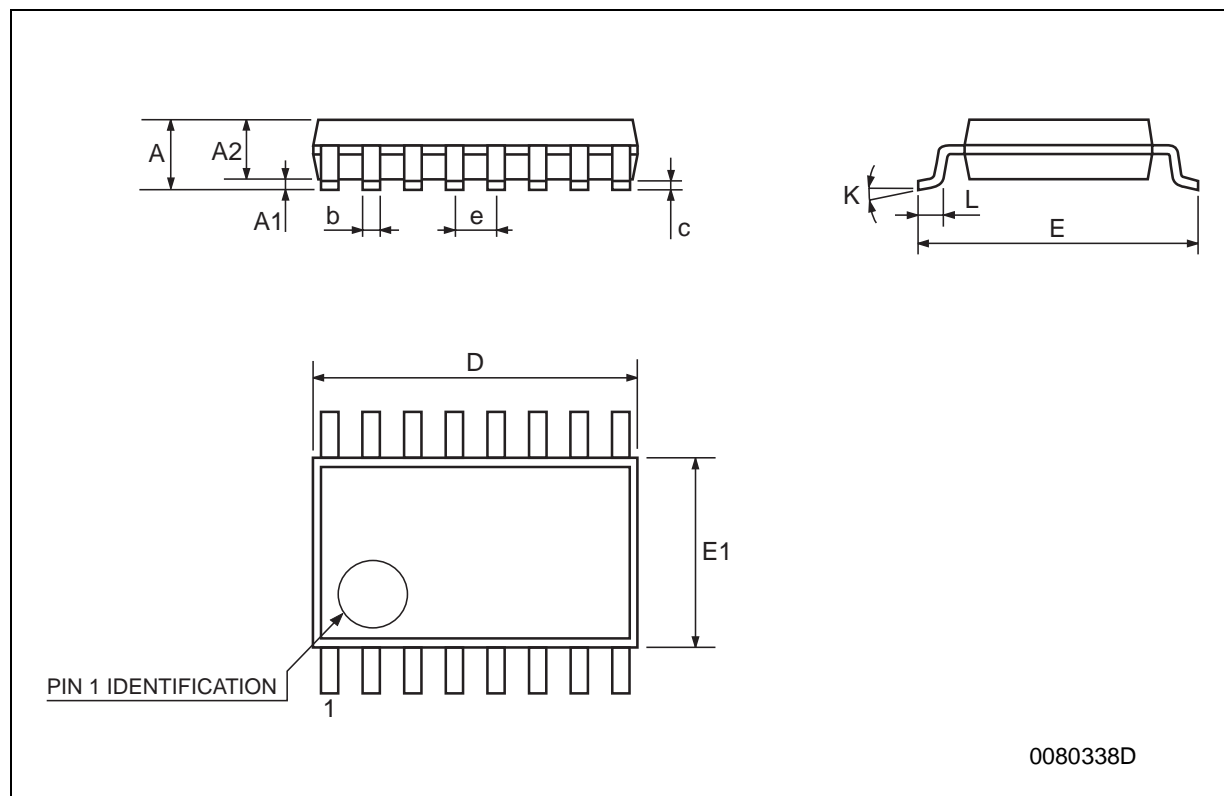

Tape & Reel SO-16 MECHANICAL DATA

DIM.	mm.			inch		
	MIN.	TYP	MAX.	MIN.	TYP.	MAX.
A			330			12.992
C	12.8		13.2	0.504		0.519
D	20.2			0.795		
N	60			2.362		
T			22.4			0.882
Ao	6.45		6.65	0.254		0.262
Bo	10.3		10.5	0.406		0.414
Ko	2.1		2.3	0.082		0.090
Po	3.9		4.1	0.153		0.161
P	7.9		8.1	0.311		0.319

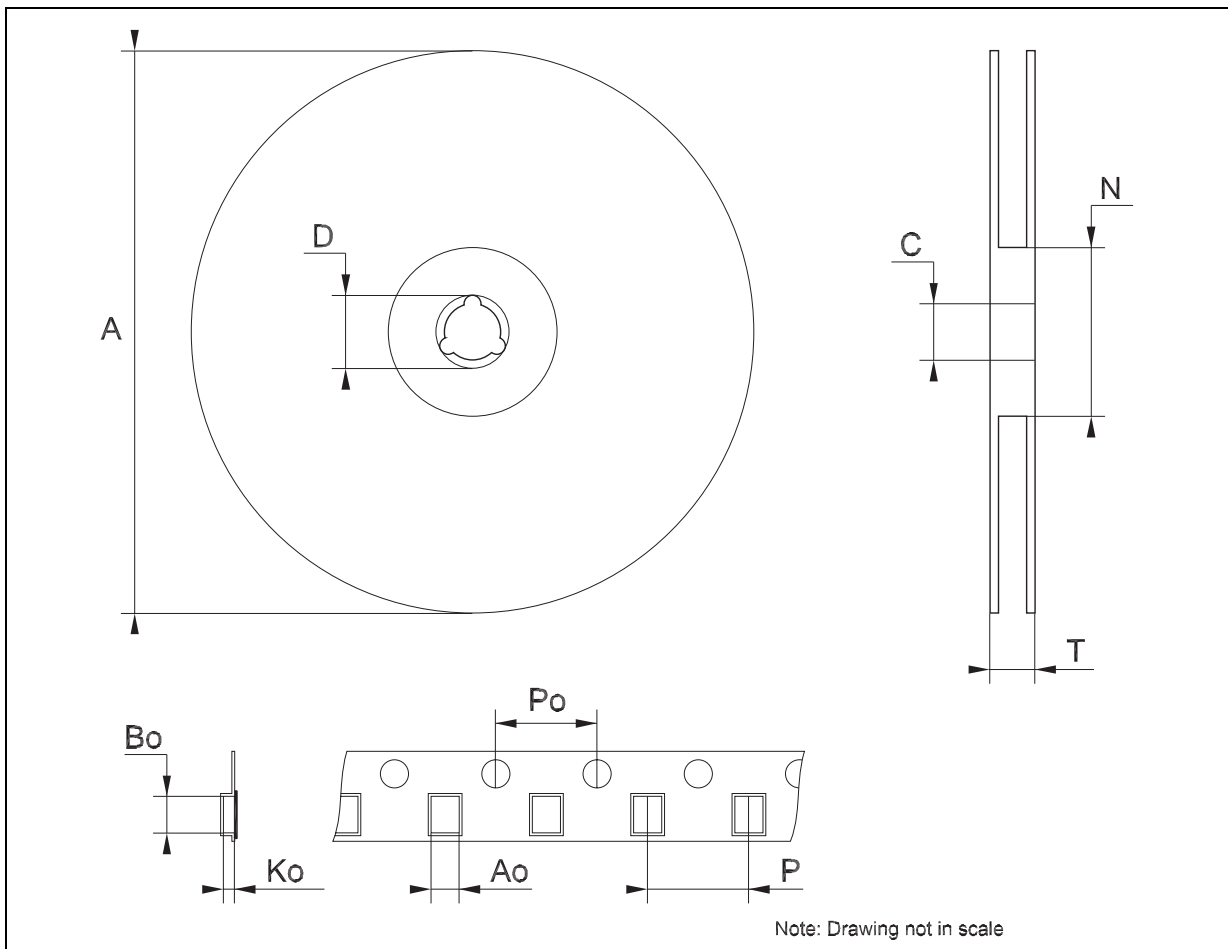

Tape & Reel TSSOP16 MECHANICAL DATA

DIM.	mm.			inch		
	MIN.	TYP	MAX.	MIN.	TYP.	MAX.
A			330			12.992
C	12.8		13.2	0.504		0.519
D	20.2			0.795		
N	60			2.362		
T			22.4			0.882
Ao	6.7		6.9	0.264		0.272
Bo	5.3		5.5	0.209		0.217
Ko	1.6		1.8	0.063		0.071
Po	3.9		4.1	0.153		0.161
P	7.9		8.1	0.311		0.319

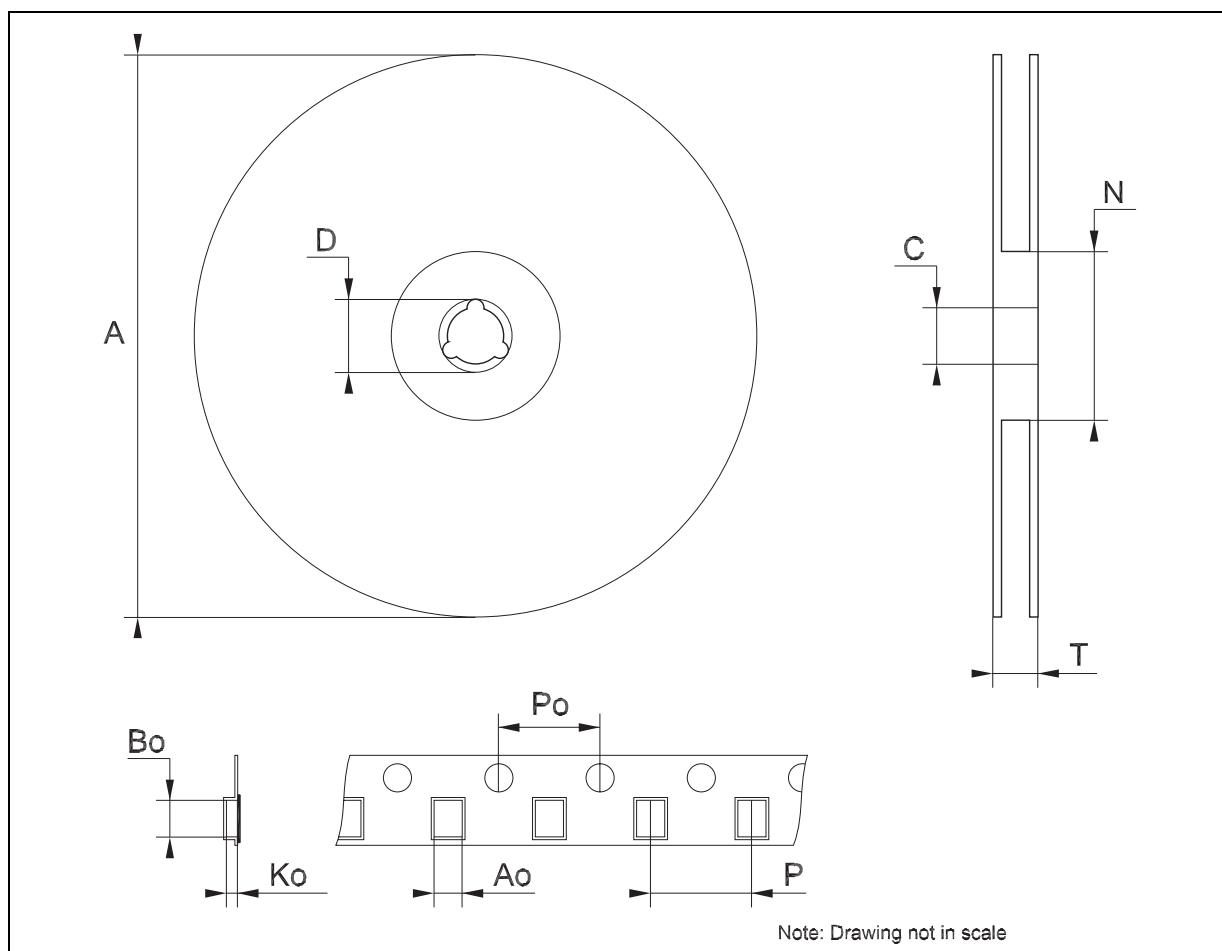

Information furnished is believed to be accurate and reliable. However, STMicroelectronics assumes no responsibility for the consequences of use of such information nor for any infringement of patents or other rights of third parties which may result from its use. No license is granted by implication or otherwise under any patent or patent rights of STMicroelectronics. Specifications mentioned in this publication are subject to change without notice. This publication supersedes and replaces all information previously supplied. STMicroelectronics products are not authorized for use as critical components in life support devices or systems without express written approval of STMicroelectronics.

© The ST logo is a registered trademark of STMicroelectronics

© 2002 STMicroelectronics - Printed in Italy - All Rights Reserved
STMicroelectronics GROUP OF COMPANIES

Australia - Brazil - Canada - China - Finland - France - Germany - Hong Kong - India - Israel - Italy - Japan - Malaysia - Malta - Morocco
Singapore - Spain - Sweden - Switzerland - United Kingdom - United States.

© <http://www.st.com>