

FEATURES

Filterless Class-D amplifier with spread-spectrum Σ - Δ modulation with integrated boost regulator (5.1 V)
 Digitized output of output voltage, output current, and VBAT supply voltage
 Integrated boost regulator
 Multiple serial data formats
 PDM input/output
 TDM slave with support for up to 8 chips on a single bus
 I²S or left justified slave
 Multichip I²S with support for up to 4 chips on one I²S bus
 8 kHz to 192 kHz PCM sample rates
 2.048 to 6.14 MHz PDM input sample rates
 Configurable via I²C control, TDM control, or PDM patterns
 Standalone control modes
 2.5 W into 4 Ω load and 1.42 W into 8 Ω load at 3.6 V supply with <1% total harmonic distortion plus noise (THD + N)
 Available in 19-ball, 1.74 mm \times 2.1 mm, 0.4 mm pitch WLCSP
 89.7% system efficiency into 8 Ω at 1 W, VBAT = 3.6 V

Output noise: 21.7 μ V rms, A-weighted
 THD + N: 0.025% at 1 kHz, 500 mW output power
 PSSR: 90 dB at 217 Hz, with dither input
 72 dB signal-to-noise ratio (SNR) on output current sensing and 77 dB SNR on voltage sensing
 Quiescent power consumption: 19.8 mW
 Pop-and-click suppression
 Flexible battery monitoring AGC
 Short-circuit protection for boost and Class-D outputs and thermal protection with automatic recovery
 Smart power-down when PDM stop condition or no clock input detected
 DC blocking high-pass filter and static input DC protection for PDM input
 Selectable ultralow EMI emissions and low latency modes

APPLICATIONS

Mobile handsets
 Tablets
 Portable media players

FUNCTIONAL BLOCK DIAGRAM

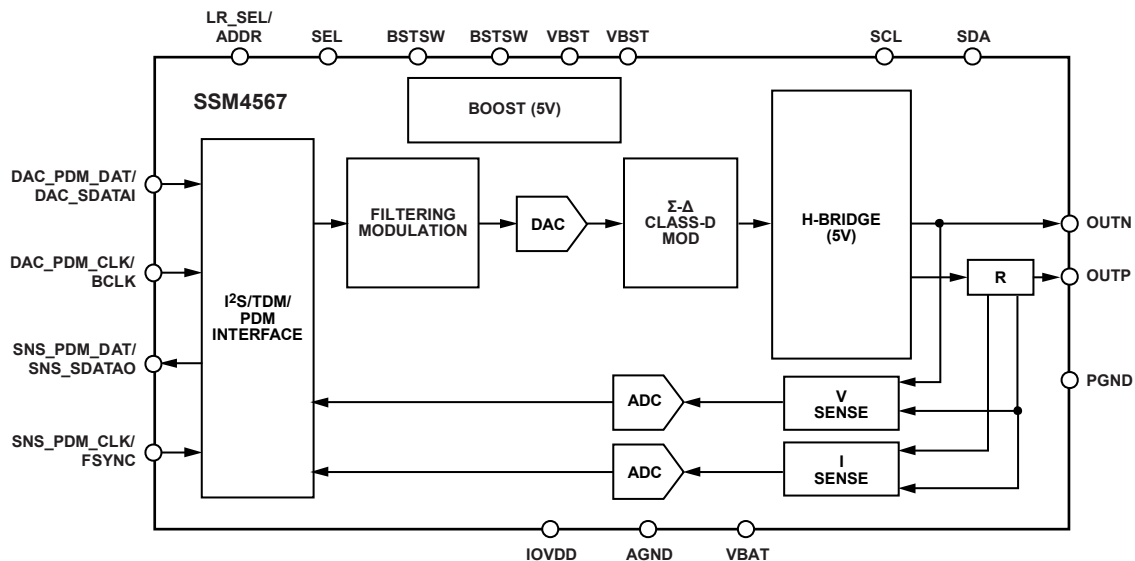

Figure 1.

12276-001

Rev. 0

Document Feedback

Information furnished by Analog Devices is believed to be accurate and reliable. However, no responsibility is assumed by Analog Devices for its use, nor for any infringements of patents or other rights of third parties that may result from its use. Specifications subject to change without notice. No license is granted by implication or otherwise under any patent or patent rights of Analog Devices. Trademarks and registered trademarks are the property of their respective owners.

TABLE OF CONTENTS

Features	1	Integrated Boost Converter.....	25
Applications.....	1	Applications Information	26
Functional Block Diagram	1	Component Selection for Boost Regulators	26
Table of Contents	2	Layout	26
Revision History	3	Power Supply Decoupling	27
General Description	4	Typical Application Circuits	28
Specifications.....	5	Software Control Mode, I ² S/TDM Interface.....	28
Digital Input/Output.....	6	Software Control Mode, PDM Interface	29
Absolute Maximum Ratings.....	7	Standalone Mode, I ² S/TDM Interface	30
Thermal Resistance	7	Pattern Control Mode, PDM Interface.....	31
ESD Caution.....	7	Register Summary	32
Pin Configuration and Function Descriptions.....	8	Register Details	33
Typical Performance Characteristics	9	Power Control Register.....	33
Theory of Operation	15	Amp and Sense Control Register	34
Modes of Operation	15	DAC Control Register.....	35
Clocking.....	15	DAC Volume Control Register	36
Power Supplies	15	Serial Audio Interface Control 1 Register	37
Power Control.....	15	Serial Audio Interface Control 2 Register	38
Power-On Reset/Voltage Supervisor	15	Serial Audio Interface Placement 1 Control Register.....	39
PDM Mode Setup and Control.....	15	Serial Audio Interface Placement 2 Control Register.....	40
PDM Pattern Control.....	16	Serial Audio Interface Placement 3 Control Register.....	41
PDM Channel Selection	17	Serial Audio Interface Placement 4 Control Register.....	42
PCM Mode Pin Setup and Control.....	17	Serial Audio Interface Placement 5 Control Register.....	43
PCM Digital Audio Serial interface	17	Serial Audio Interface Placement 6 Control Register.....	43
Serial Data Placement.....	17	Battery Voltage Output Register.....	44
Stereo (I ² S/Left Justified) Operating Mode.....	19	Limiter Control 1 Register	44
Right Justified Data	19	Limiter Control 2 Register	45
TDM Operating Mode.....	19	Limiter Control 3 Register	46
Multichip I ² S Operating Mode	20	Status 1 Register.....	47
System Gain.....	20	Status 2 Register.....	47
Output Current Sensing	21	Fault Control Register.....	48
Output Voltage Sensing	21	PDM Control Register	49
VBAT Sensing	21	MCLK Ratio Setting Register	49
Limiter and Battery Tracking Threshold Control.....	21	Boost Control 1 Register	50
I ² C Control	22	Boost Control 2 Register	51
TDM Control Interface.....	24	Soft Reset Register.....	51
Standalone Mode Control	24	Outline Dimensions	52
EMI Noise.....	24	Ordering Guide	52
Output Modulation Description	24		

REVISION HISTORY

4/14—Revision 0: Initial Version

GENERAL DESCRIPTION

The [SSM4567](#) is a digital input Class-D power amplifier that includes an integrated boost converter, allowing higher output power than with a normal battery supply. This means that maximum output power is constant across the battery voltage range. The [SSM4567](#) is ideal for power sensitive applications where system noise can corrupt the small analog signal sent to the amplifier, such as mobile phones, tablets, and portable media players.

The [SSM4567](#) combines an audio digital-to-analog converter (DAC), a power amplifier, and PDM or PCM (I²S/TDM) digital audio interfaces on a single chip. Using the [SSM4567](#), audio can be transmitted digitally to the audio amplifier, significantly reducing the effect of noise sources on the transmitted audio and eliminate the need for input coupling capacitors. The [SSM4567](#) is capable of delivering 2.5 W of continuous output power with <1% THD + N driving a 4 Ω load from a 3.6 V supply.

The [SSM4567](#) can be controlled by I²C, PDM pattern control, or TDM control. It can also operate in standalone mode without a control interface.

The [SSM4567](#) includes circuitry to sense output current, output voltage, and the VBAT supply voltage. Current sensing is performed using an on-chip sense resistor that is connected between an output pin and the load. Output current and voltage

are sent to an ADC. The outputs of these ADCs are available on the digital serial output port. The VBAT supply voltage can be used with an automatic gain control circuit that is fully configurable. This AGC can limit the maximum output at low battery voltages to avoid drawing too much current from the battery, thereby extending battery life.

The [SSM4567](#) features a high efficiency, low noise modulation scheme that requires no external LC output filters. The closed-loop, five-level modulator design retains the benefits of an all digital amplifier, yet enables very good PSRR and audio performance. The modulation continues to provide high efficiency even at low output power and has an SNR of 104 dB, A-weighted. Spread spectrum pulse density modulation is used to provide lower EMI radiated emissions compared with other Class-D architectures.

The [SSM4567](#) has a micropower shutdown mode with a typical shutdown current of 0.2 μ A for the VBAT power supply. Shutdown is enabled automatically by gating input clock and data signals.

The [SSM4567](#) is specified over the industrial temperature range of -40°C to $+85^{\circ}\text{C}$. It has a built-in thermal shutdown and amplifier and boost output short-circuit protection. It is available in a 19-ball, 1.74 mm \times 2.1 mm wafer level chip scale package (WLCSP).

SPECIFICATIONS

VBAT = 3.6 V, IOVDD = 1.8 V, T_A = 25°C, R_L = 8 Ω + 33 μH, VBST = 5.1 V, 20 Hz to 20 kHz bandwidth (BW), unless otherwise noted. In PDM operation, PDM clock = 3.072 MHz; for PCM operation, f_s = 48 kHz.

Table 1.

Parameter	Symbol	Conditions	Min	Typ	Max	Unit
AMPLIFIER CHARACTERISTICS						
Output Power/Channel	P _{OUT}	R _L = 8 Ω, THD = 1%, f = 1 kHz, R _L = 8 Ω, THD = 10%, f = 1 kHz R _L = 4 Ω, THD = 1%, f = 1 kHz R _L = 4 Ω, THD = 10%, f = 1 kHz		1.43 1.81 2.49 3.17		W W W W
System Efficiency	η	P _O = 1 W, VBAT = 3.6 V, R _L = 8 Ω		89.7		%
Total Harmonic Distortion + Noise	THD + N	f = 1 kHz, P _O = 1 W, R _L = 8 Ω		0.031		%
Output Voltage Noise	e _n	f = 1 kHz, P _O = 0.5 W, R _L = 8 Ω VBST = 5.1 V, 20 kHz BW, dither input, A-weighted		0.025 21.7		% μV rms
Signal-to-Noise Ratio	SNR	A-weighted, referred to output at 1% THD		104		dB
Average Switching Frequency	f _{sw}			300		kHz
Full-Scale Output Voltage		0 dBFS PCM or –6 dBFS PDM input		5.17		V peak
Differential Output Offset Voltage	V _{OOS}			1.1		mV
POWER SUPPLIES						
Supply Voltage Range	VBAT IOVDD		2.5 1.62	3.6 1.8	5.2 1.98	V V
Power Supply Rejection Ratio	DC PSRR PSRR _{GSM}	Dither input Dither input, V _{ripple} = 100 mV on VBAT at 217 Hz		70 90		dB dB
Quiescent Supply Current						
VBAT	I _{VBAT}	VBAT = 3.6 V		4.86		mA
IOVDD	I _{IOVDD}	IOVDD = 1.8 V, PDM clock = 3.072 MHz		1.28		mA
Shutdown Current						
VBAT	I _{VBAT}	VBAT = 3.6 V, no input clocks		0.2	1	μA
IOVDD	I _{IOVDD}	IOVDD = 1.8 V, no input clocks		2.8		μA
SHUTDOWN CONTROL						
Turn-On Time	t _{WU}			3		ms
Turn-Off Time	t _{SD}			10		μs
Output Impedance	Z _{OUT}			86		kΩ
CLOCKING AND SAMPLE RATES						
Input and Output Sampling Rate, PCM	f _s	LRCLK rate	8		192	kHz
BCLK Frequency, PCM	f _{BCLK}		2.048		24.576	MHz
Input Sampling Rate, PDM	f _{DAC_PDM_CLK}		2.048		6.144	MHz
Output Sampling Rate, PDM	f _{SNS_PDM_CLK}		1.024		6.144	MHz
OUTPUT SENSING						
Voltage Sense Signal-to-Noise Ratio	SNR _V	A-weighted		77		dB
Voltage Sense Full Scale	VFS	Output voltage at 0 dBFS PCM/–6 dBFS PDM output from ADC		6		V peak
Voltage Sense Absolute Accuracy				1.5		%
Voltage Sense Gain Drift		Temperature, T _A = 10°C to 60°C		1		%
Current Sense Signal-to-Noise Ratio	SNR _I	A-weighted		72		dB
Current Sense Input Full-Scale Voltage	IFS	Voltage across sense resistor with 0 dBFS PCM/–6 dBFS PDM output from ADC		1.78		A peak

Parameter	Symbol	Conditions	Min	Typ	Max	Unit
Current Sense Absolute Accuracy				1.5		%
Current Sense Gain Drift		$T_A = 10^\circ\text{C to } 60^\circ\text{C}$		1.5		%
VBAT Sense Full-Scale Range			2		6	V
VBAT Sense Absolute Accuracy				3		%
Current and Voltage Sense Linearity		From -80 dB to 0 dB			1	dB
BOOST CONVERTER						
Output Voltage	V_{OUT}			5.1		V
Input Current Limit	I_{MAX}			2.2		A
Soft Start Current Limit				0.25		A
Line Regulation				0.20		%/V
Load Regulation				0.15		%/A
Inductor			1	2.2		μH
Input Capacitor			10			μF
Output Capacitor			10	22		μF
PMOS Switch Resistance	R_{ONP}	$V_{\text{BAT}} = 3.6\text{ V}, V_{\text{BST}} = 5.1\text{ V}$		80		$\text{m}\Omega$
NMOS Switch Resistance	R_{ONN}	$V_{\text{BAT}} = 3.6\text{ V}, V_{\text{BST}} = 5.1\text{ V}$		55		$\text{m}\Omega$
Switching Frequency	f_{BOOSTSW}			1.536		MHz
Efficiency	η_{BOOST}	200 mA output		91		%
AUTOMATIC GAIN CONTROL						
AGC Gain Attack Time			20		120	$\mu\text{s}/\text{dB}$
AGC Gain Release Time			0.8	1.6	3.2	sec/dB
Battery Inflection Point		VBAT supply when threshold reduction starts	3.2	3.5	3.9	V
VBAT vs. Limiter Slope			1	3	4	V/V
AGC Gain Step Size				0.1875		dB

DIGITAL INPUT/OUTPUT

Table 2.

Parameter	Symbol	Min	Typ	Max	Unit
INPUT VOLTAGE					
High	V_{IH}	$0.7 \times \text{IOVDD}$		3.6	V
Low	V_{IL}	-0.3		$+0.3 \times \text{IOVDD}$	V
ADDR		-0.3		$\text{IOVDD} + 0.3$	V
INPUT LEAKAGE					
High	I_{IH}			1	μA
Low	I_{IL}			1	μA
INPUT CAPACITANCE					
				5	pF
OUTPUT DRIVE STRENGTH					
			4.5		mA

ABSOLUTE MAXIMUM RATINGS

Absolute maximum ratings apply at 25°C, unless otherwise noted.

Table 3.

Parameter	Rating
VBAT Supply Voltage	−0.3 V to +6 V
IOVDD Supply Voltage	−0.3 V to +2 V
Input Voltage	−0.3 V to +6 V
Storage Temperature Range	−65°C to +150°C
Operating Temperature Range	−40°C to +85°C
Junction Temperature Range	−65°C to +165°C
Soldering Conditions	JEDEC J-STD-020

Stresses at or above those listed under Absolute Maximum Ratings may cause permanent damage to the product. This is a stress rating only; functional operation of the product at these or any other conditions above those indicated in the operational section of this specification is not implied. Operation beyond the maximum operating conditions for extended periods may affect product reliability.

THERMAL RESISTANCE

θ_{JA} (junction to air) is specified for the worst-case conditions, that is, a device soldered in a circuit board for surface-mount packages. θ_{JA} is determined according to JESD51-9 on a 4-layer printed circuit board (PCB) with natural convection cooling. For more information, see the [AN-617 Application Note, Wafer Level Chip Scale Package](#) at www.analog.com.

Table 4. Thermal Resistance

Package Type	θ_{JA}	Unit
19-Ball, 1.74 mm × 2.1 mm WLCSP	57.73	°C/W

ESD CAUTION



ESD (electrostatic discharge) sensitive device.

Charged devices and circuit boards can discharge without detection. Although this product features patented or proprietary protection circuitry, damage may occur on devices subjected to high energy ESD. Therefore, proper ESD precautions should be taken to avoid performance degradation or loss of functionality.

PIN CONFIGURATION AND FUNCTION DESCRIPTIONS

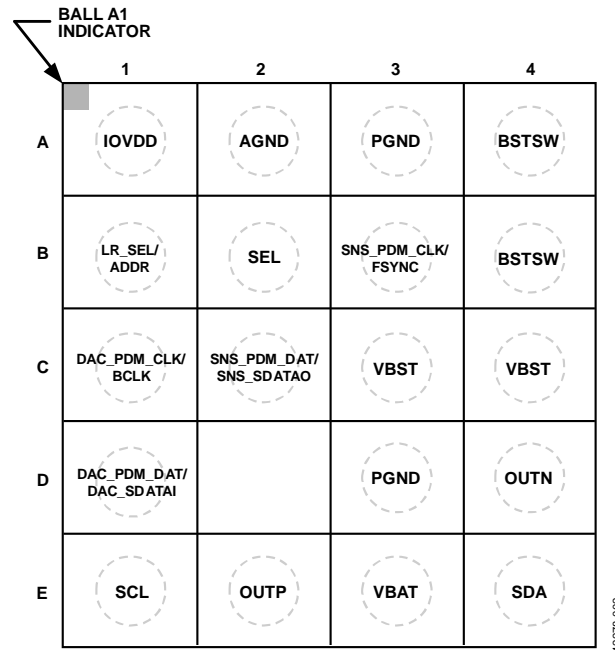

Figure 2. Pin Configuration

Table 5. Pin Function Descriptions

Pin No.	Mnemonic	Description
A1	IOVDD	I/O and Digital Power
A2	AGND	Analog Ground
A3	PGND	Power Amplifier Ground
A4	BSTSW	Boost Switch
B1	LR_SEL/ADDR	Left or Right Selection for PDM Input/I ² C Address
B2	SEL	PDM or I ² S/TDM Interface Mode Select
B3	SNS_PDM_CLK/FSYNC	PDM Output Clock for Sense Data in PDM Mode/Frame Synchronization Clock in I ² S/TDM Mode
B4	BSTSW	Boost Switch
C1	DAC_PDM_CLK/BCLK	PDM Input Clock in PDM Mode/Bit Clock in I ² S/TDM Mode
C2	SNS_PDM_DAT/SNS_SDATAO	Sense Data Output for PDM Mode/Sense Data Output for I ² S/TDM Mode
C3	VBST	Boost Converter Output
C4	VBST	Boost Converter Output
D1	DAC_PDM_DAT/DAC_SDATAI	PDM Data Input for DAC in PDM Mode/Serial Data Input for DAC in I ² S/TDM Mode
D3	PGND	Power Amplifier Ground
D4	OUTN	Inverting Class-D Amplifier Output
E1	SCL	I ² C Clock Signal
E2	OUTP	Noninverting Class-D Amplifier Output
E3	VBAT	External Battery Power Supply
E4	SDA	I ² C Data Signal

TYPICAL PERFORMANCE CHARACTERISTICS

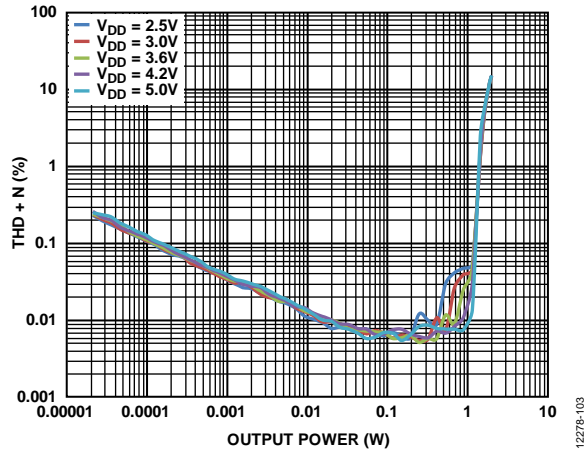

Figure 3. THD + N vs. Output Power at $R_L = 8\ \Omega$ and $33\ \mu\text{H}$

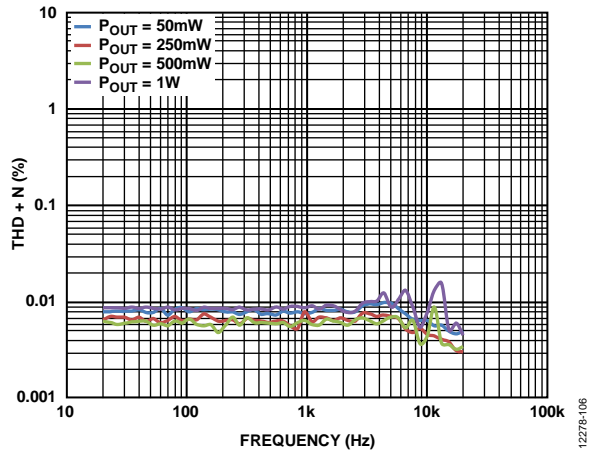

Figure 6. THD + N vs. Frequency at $V_{BAT} = 4.2\ \text{V}$, $R_L = 8\ \Omega$ and $33\ \mu\text{H}$

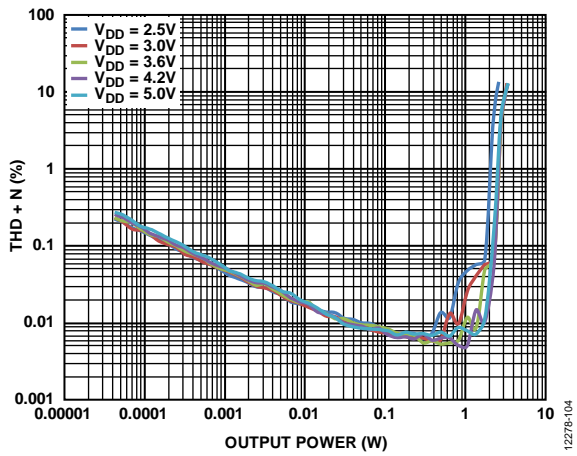

Figure 4. THD + N vs. Output Power at $R_L = 4\ \Omega$ and $15\ \mu\text{H}$

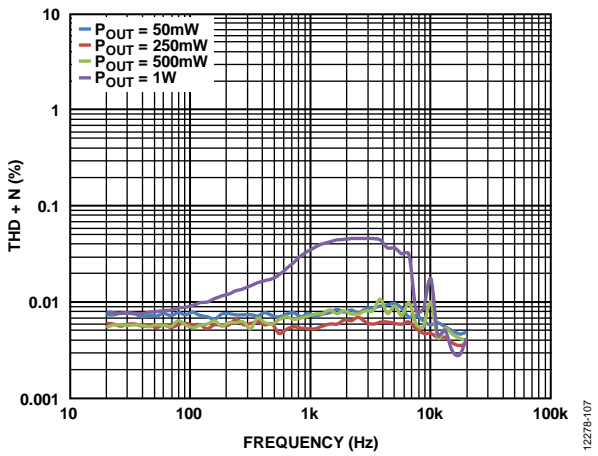

Figure 7. THD + N vs. Frequency at $V_{BAT} = 3.6\ \text{V}$, $R_L = 8\ \Omega$ and $33\ \mu\text{H}$

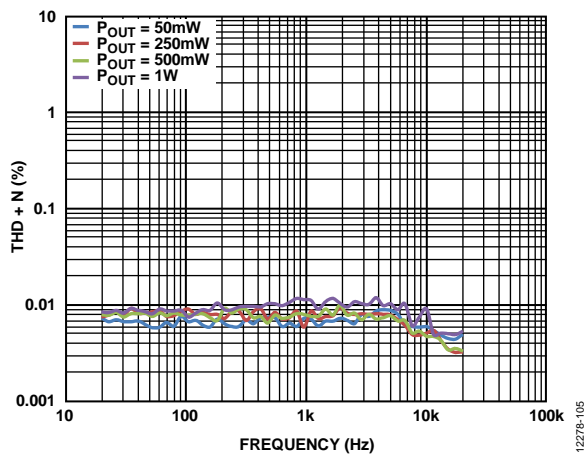

Figure 5. THD + N vs. Frequency at $V_{BAT} = 5\ \text{V}$, $R_L = 8\ \Omega$ and $33\ \mu\text{H}$

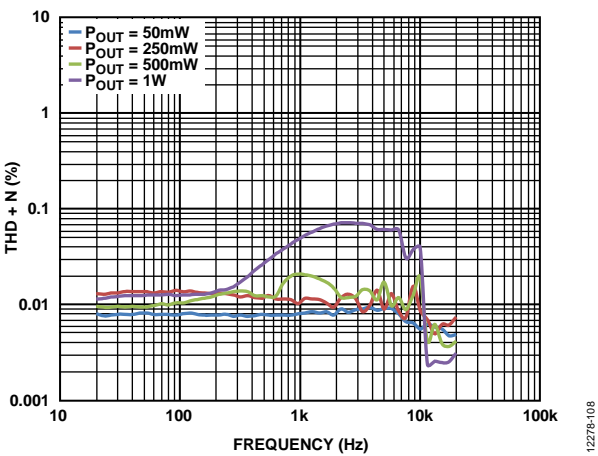

Figure 8. THD + N vs. Frequency at $V_{BAT} = 2.5\ \text{V}$, $R_L = 8\ \Omega$ and $33\ \mu\text{H}$

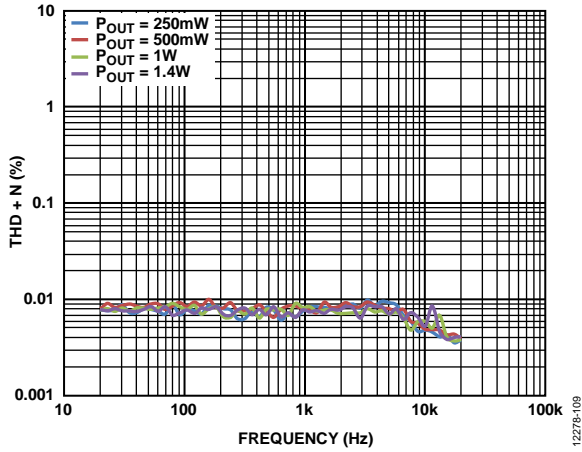

Figure 9. THD + N vs. Frequency at $V_{BAT} = 5\text{ V}$, $R_L = 4\ \Omega$ and $15\ \mu\text{H}$

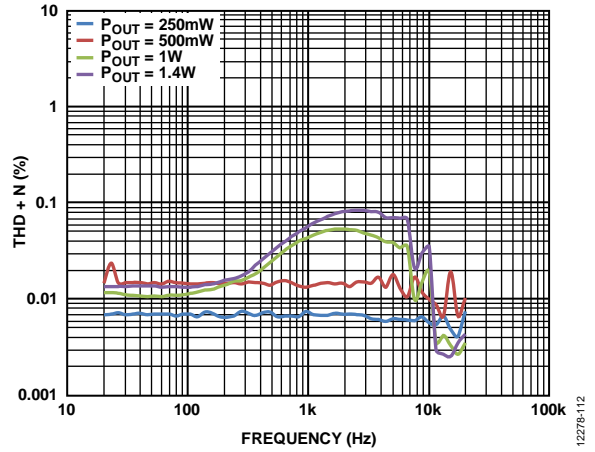

Figure 12. THD + N vs. Frequency at $V_{BAT} = 2.5\text{ V}$, $R_L = 4\ \Omega$ and $15\ \mu\text{H}$

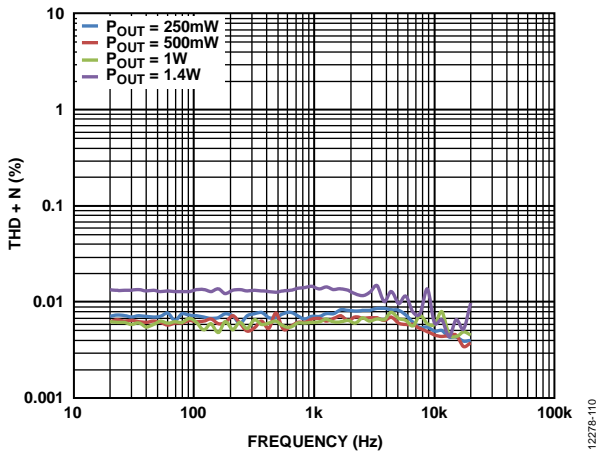

Figure 10. THD + N vs. Frequency at $V_{BAT} = 4.2\text{ V}$, $R_L = 4\ \Omega$ and $15\ \mu\text{H}$

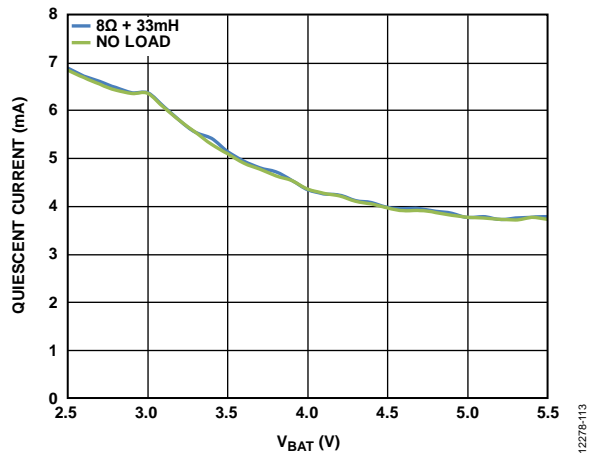

Figure 13. Quiescent Current vs. V_{BAT} Supply Voltage

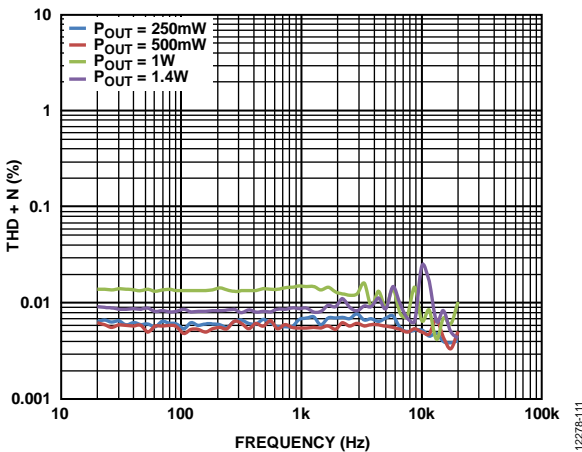

Figure 11. THD + N vs. Frequency at $V_{BAT} = 3.6\text{ V}$, $R_L = 4\ \Omega$ and $15\ \mu\text{H}$

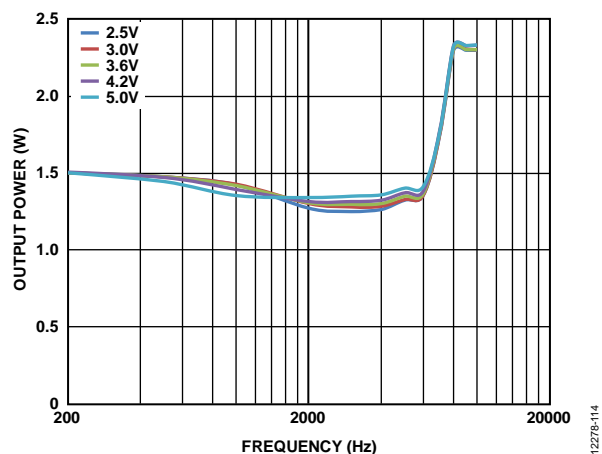

Figure 14. Output Power vs. Frequency at $R_L = 8\ \Omega$, $THD + N = 1\%$

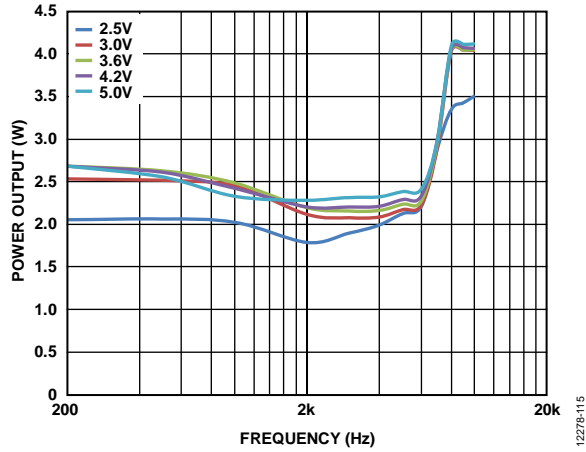

Figure 15. Output Power vs. Frequency at $R_L = 4 \Omega$, THD + N = 1%

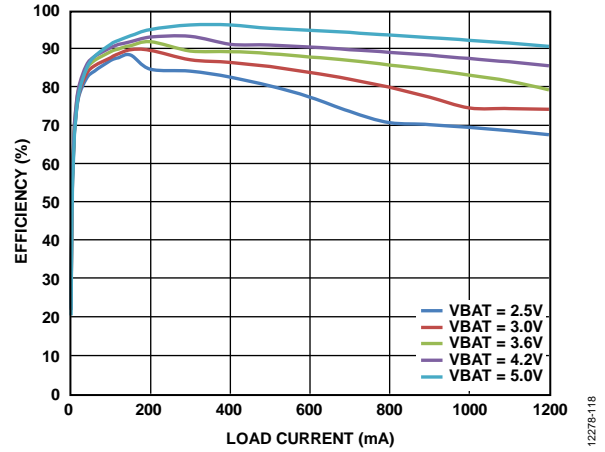

Figure 18. Boost Efficiency vs. Output Current, Boost Inductor = $2.2 \mu\text{H}$ at 3.072 MHz

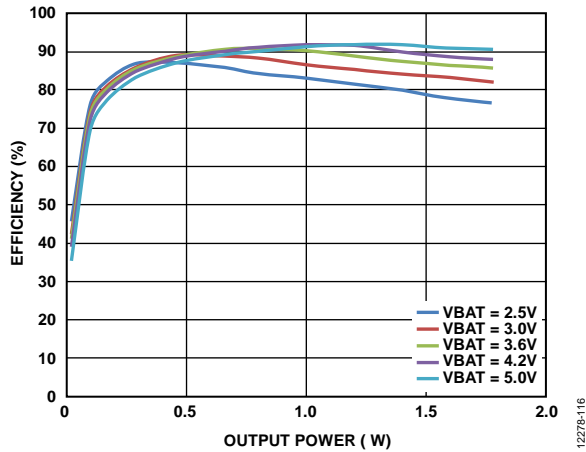

Figure 16. Efficiency vs. Output Power, Boost Inductor = $2.2 \mu\text{H}$, $R_L = 8 \Omega$ and $33 \mu\text{H}$

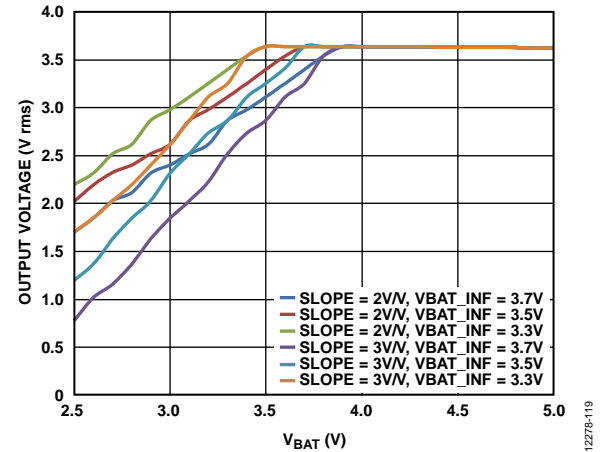

Figure 19. Output Voltage vs. V_{BAT} Supply Voltage, Limiter Threshold = 5.4 V

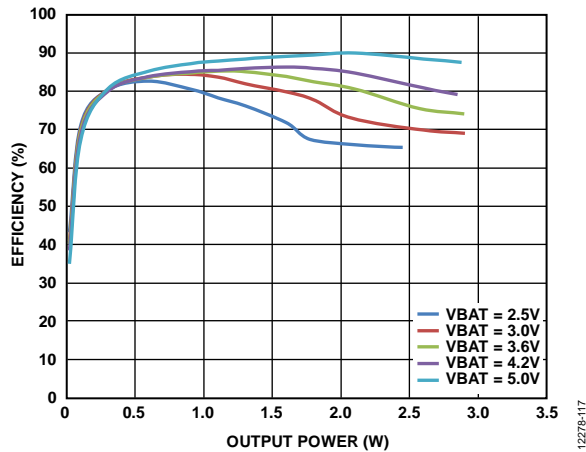

Figure 17. Efficiency vs. Output Power, Boost Inductor = $2.2 \mu\text{H}$, $R_L = 4 \Omega$ and $15 \mu\text{H}$

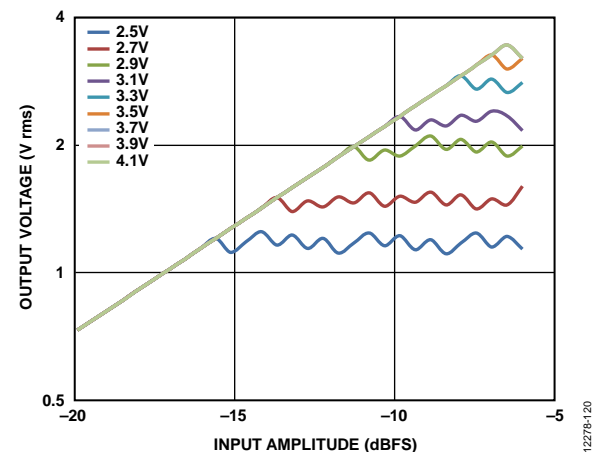

Figure 20. Output Voltage vs. Input Amplitude

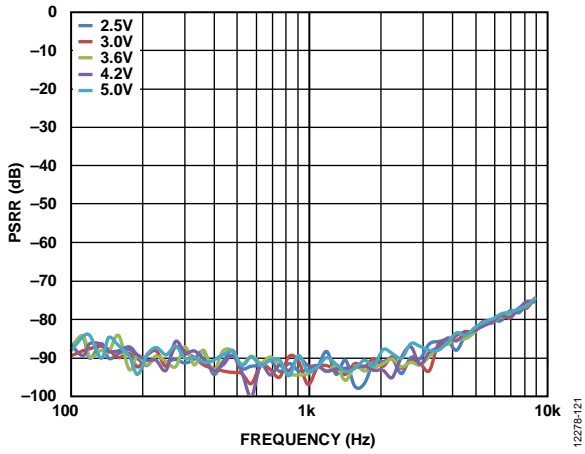

Figure 21. Power Supply Rejection Ratio (PSRR) vs. Frequency, $R_L = 8 \Omega$

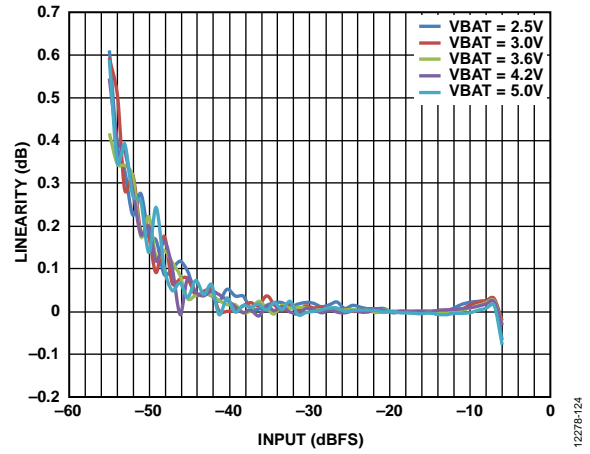

Figure 24. Linearity of the Current Sense vs. Input Level, $R_L = 8 \Omega$ and $33 \mu H$

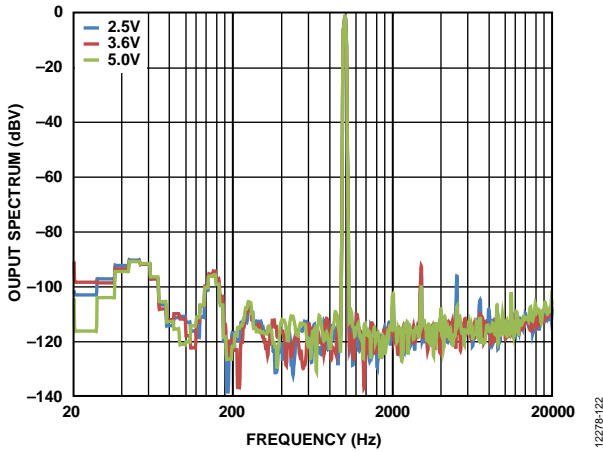

Figure 22. Output Spectrum vs. Frequency (FFT), Output Power = 100 mW, $R_L = 8 \Omega$, 1 kHz input

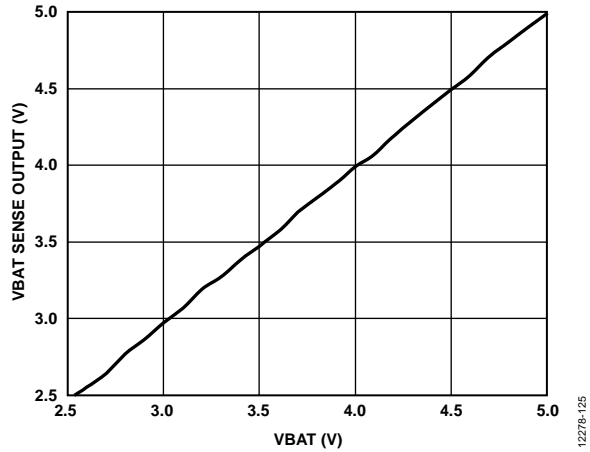

Figure 25. VBAT ADC Sense Level Output vs. VBAT Supply Voltage, $R_L = 8 \Omega$

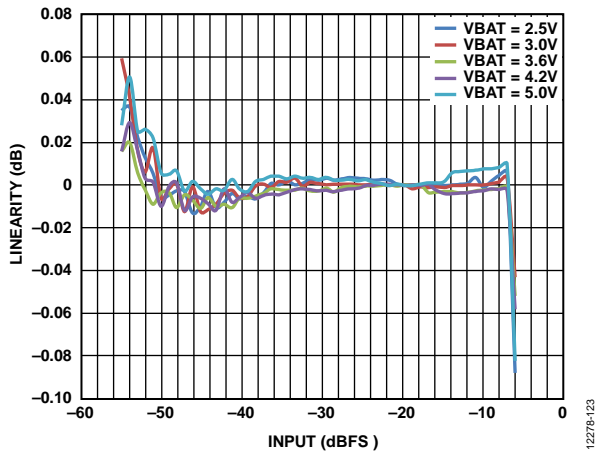

Figure 23. Linearity of the Voltage Sense vs. Input Level, $R_L = 8 \Omega$ and $33 \mu H$

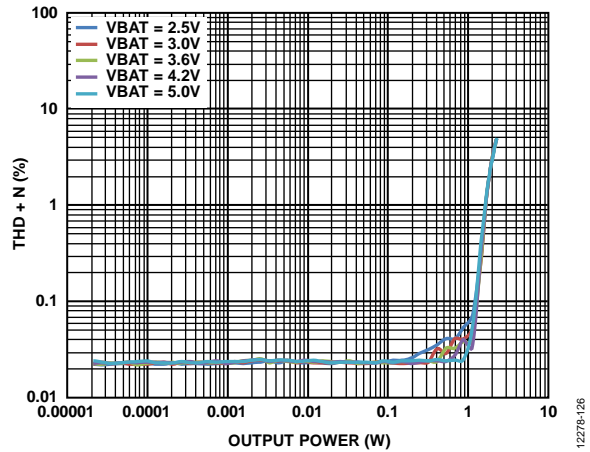

Figure 26. Current Sense THD + N vs. Output Power, $R_L = 8 \Omega$ and $33 \mu H$

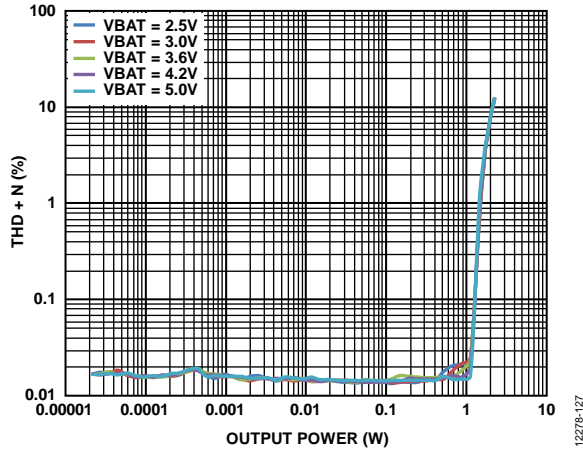

Figure 27. Voltage Sense THD + N vs. Output Power, $R_L = 8\ \Omega$ and $33\ \mu\text{H}$

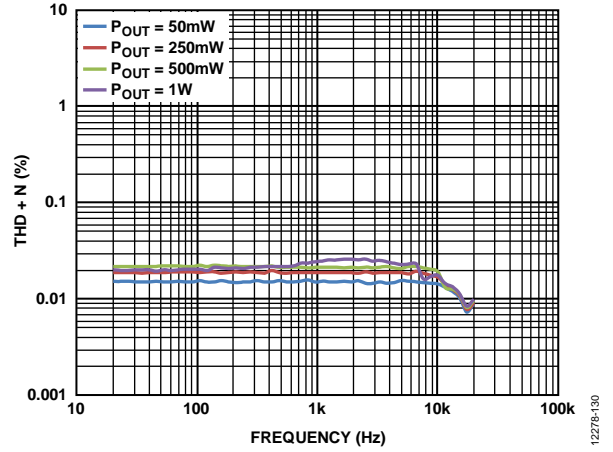

Figure 30. Voltage Sense THD + N vs. Frequency, $V_{BAT} = 3.6\ \text{V}$, $R_L = 8\ \Omega$ and $33\ \mu\text{H}$

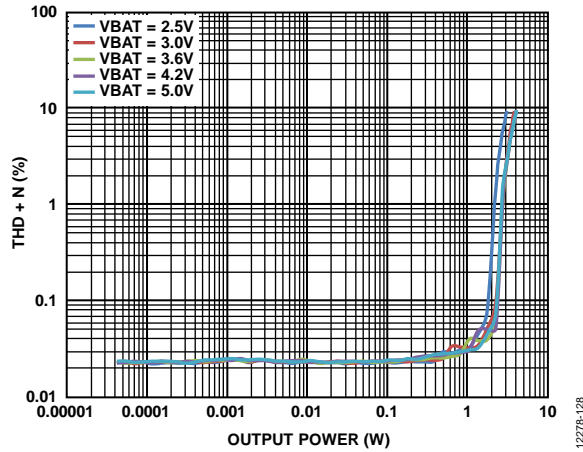

Figure 28. Current Sense THD + N vs. Output Power, $R_L = 4\ \Omega$ and $15\ \mu\text{H}$

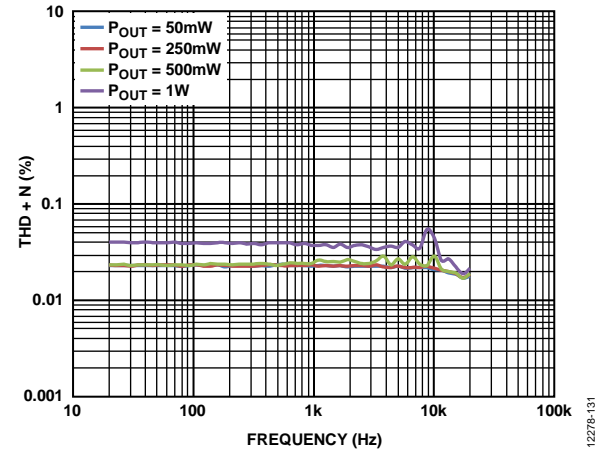

Figure 31. Current Sense THD + N vs. Frequency, $V_{BAT} = 3.6\ \text{V}$, $R_L = 8\ \Omega$ and $33\ \mu\text{H}$

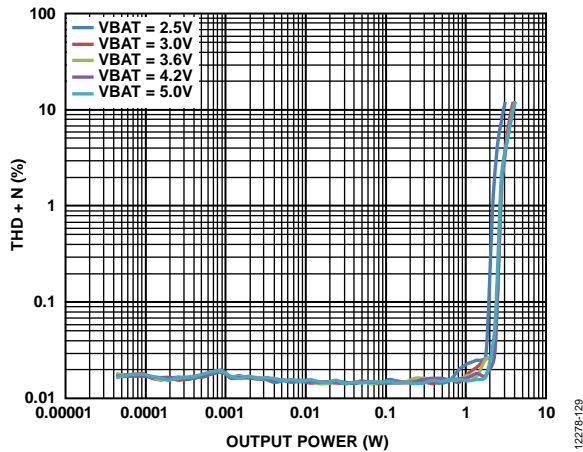

Figure 29. Voltage Sense THD + N vs. Output Power, $R_L = 4\ \Omega$ and $15\ \mu\text{H}$

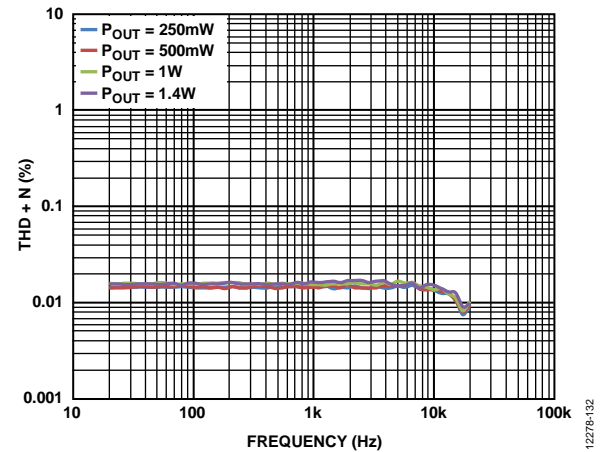

Figure 32. Voltage Sense THD + N vs. Frequency, $V_{BAT} = 3.6\ \text{V}$, $R_L = 4\ \Omega$ and $15\ \mu\text{H}$

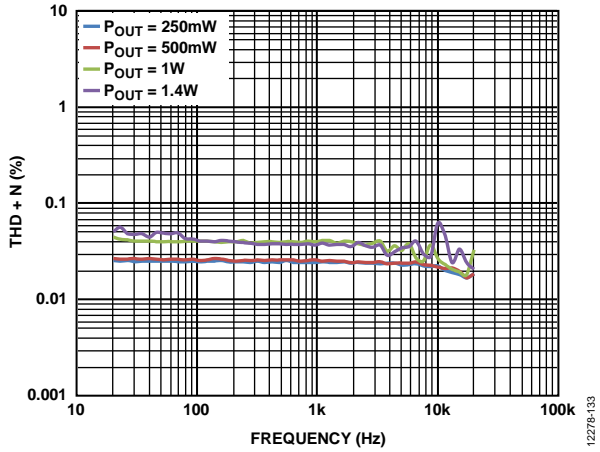

Figure 33. Current Sense THD + N vs. Frequency, $V_{BAT} = 3.6V$, $R_L = 4\Omega$ and $15\mu H$

12278-133

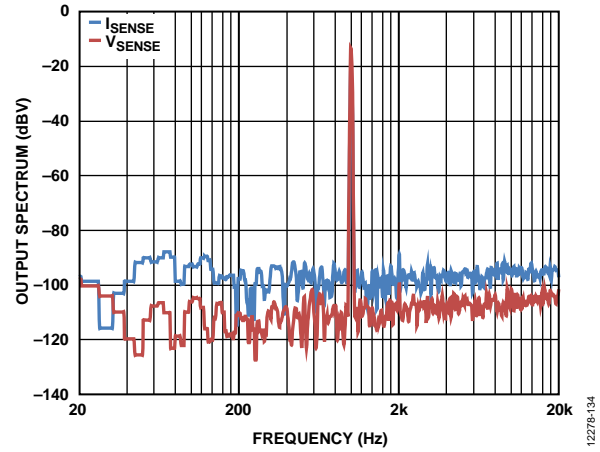

Figure 34. Output Spectrum of Sense ADC vs. Frequency
Output Power = 100 mW, $R_L = 8\Omega$

12278-134

THEORY OF OPERATION

MODES OF OPERATION

The [SSM4567](#) has several modes of control and audio I/O operation. Audio and sense data can be sent to and from the [SSM4567](#) in 1-bit PDM format by tying the SEL pin to AGND or multibit PCM format by tying the SEL pin to IOVDD. With PCM data, the serial audio interface can be configured for I²S, left justified, or TDM formatting. The [SSM4567](#) can be controlled using I²C, PDM pattern control, TDM control, or standalone operation. See Table 10 for more details.

CLOCKING

The [SSM4567](#) requires a clock present at the DAC_PDM_CLK/BCLK input pin to operate. This clock must be fully synchronous with the incoming digital data. The clock frequencies must fall in the range of 2.048 MHz to 24.576 MHz for PCM mode, or 2.048 MHz to 6.144 MHz for PDM mode.

In standalone I²S mode, the required clock must be present on the SNS_PDM_CLK/FSYNC pin.

POWER SUPPLIES

The [SSM4567](#) requires two power supplies: VBAT and IOVDD.

VBAT

VBAT supplies power to the boost converter and its associated drive, control, and protection circuitry. VBAT can operate from 2.5 V to 5.2 V and must be present to obtain audio output.

IOVDD

IOVDD provides power to the digital logic circuitry and the I/O drive circuitry. IOVDD can operate from 1.62 V to 1.98 V and must be present to obtain audio output.

Power Sequencing

On device power-up, VBAT must be applied to the device first. The timing of the IOVDD following VBAT is not important. See the Power-On Reset/Voltage Supervisor section for more details.

POWER CONTROL

The [SSM4567](#) can be powered down by several methods. If using I²C or TDM control, a software power-down control SPWDN fully powers down the device. PDM pattern control has a standby pattern that powers down all blocks except the PDM interface.

For lowest power shutdown, the [SSM4567](#) also contains a clock loss detection circuit that looks at the DAC_PDM_CLK/BCLK input clock. When DAC_PDM_CLK/BCLK is absent, the device automatically powers down all internal circuitry to its lowest power state. When DAC_PDM_CLK/BCLK returns, the device automatically powers up following its usual power sequence.

There is an optional automatic power-down feature in which the device enters a lower power state after 2048 consecutive zero input samples have been received when in PCM operation. Only the I²C and digital audio input blocks remain active.

The output current, output voltage, and VBAT sensing can be turned off independently via the ISNS_PWDN, VSNS_PWDN, and BSNS_PWDN control bits. This can save power if the amplifier operation is needed but not the output sensing.

The amplifier and boost converter can be powered down independently via the AMP_PWDN and BOOST_PWDN control bits. When the boost is powered down and the amplifier is still active, the amplifier runs directly from the VBAT supply. This same VBAT only operation can be entered with the boost still active with the VBAT_ONLY bit. The amplifier can be powered down with the boost still enabled so the boost output can be used for other functions.

POWER-ON RESET/VOLTAGE SUPERVISOR

The [SSM4567](#) includes an internal power-on reset and voltage supervisor circuit. This circuit provides an internal reset to all circuitry whenever VBAT or IOVDD is substantially below the nominal operating threshold. This simplifies supply sequencing during initial power-on.

The circuit also monitors the power supplies to the IC. If the supply voltages fall below the nominal operating threshold, this circuit stops the output and issues a reset. This ensures that no damage occurs due to low voltage operation and that no pops can occur under nearly any power removal condition.

PDM MODE SETUP AND CONTROL

The [SSM4567](#) can operate using 1-bit PDM data for both its input and for the sense outputs. In PDM mode, control can be done either by PDM control patterns or with I²C. If the SEL pin is tied to AGND, the [SSM4567](#) starts up and operate in PDM pattern control mode.

The [SSM4567](#) can also operate in PDM via I²C control mode. A regular I²C operating address can be set on the LR_SEL/ADDR pin. Then, using I²C, the device can be set into PDM mode by writing a 1 to the PDM_MODE control bit. The PDM_LR_SEL bit selects which input channel is used.

In PDM operating mode mode, the 1-bit PDM input to the DAC is received on the DAC_PDM_DAT/DAC_SDATAI pin. The DAC_PDM_CLK/BCLK pin provides the system clock and is used for clocking in the input data. Output voltage and current sense are output on the SNS_PDM_DAT/SNS_SDATAO pin. The output can be sent at a different rate from the input, and the SNS_PDM_CLK/FSYNC pin determines the sense output rate. Alternatively, the output rate can be sent at the same rate as the input and only one clock pin, DAC_PDM_CLK/BCLK, is needed to operate the device. To use only one clock, set the SHARED_CLOCK register to 1.

Full-scale voltage for both the input and output is mapped to -6 dBFS on the PDM stream.

The PDM data input is registered directly on each clock edge. The data transition on the PDM data output is delayed relative to the clock edge.

Table 6. PDM Timing Parameters

Parameter	Limit		Unit	Description
	t _{MIN}	t _{MAX}		
t _{FALL}		10	ns	Clock fall time
t _{RISE}		10	ns	Clock rise time
t _{SETUP}	10		ns	Data setup time
t _{HOLD}	7		ns	Data hold time

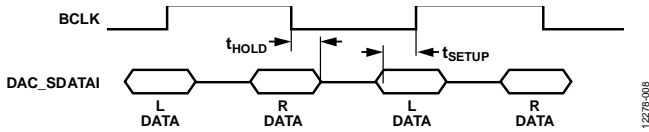

Figure 35. PDM Input Data Format

The PDM data is output on both edges of the clock. The current sense ADC data is output when SNS_PDM_CLK/FSYNC is high and should be read on the falling edge. The voltage sense ADC data is output when SNS_PDM_CLK/FSYNC is low and should be read on the rising edge.

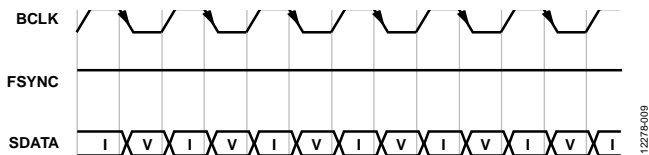

Figure 36. SDATA (DAC_SDATAI/SNS_SDATAO) Output in PDM Mode

By default in PDM mode, PDM pattern control is used for control information. I²C control can be used instead, but do not use both at the same time. If PDM pattern control is engaged, then registers associated with the PDM pattern control do not function using I²C. Writes to those registers are ignored and reads do not reflect the current state of the device. For I²C control, it is best to tie the SEL pin to IOVDD and then set the PAT_CTRL_EN bit to 0 to disable PDM pattern control before any other I²C writes or reads are performed. By default, the I²C device address in PDM mode is 0x34. By setting the I2C_ADDR_SET bit, the device address can be either 0x34 or 0x35, depending on the state of the LR_SEL/ADDR pin.

PDM PATTERN CONTROL

PDM mode operation has a simple control mechanism that can set the device for low power states and control functionality. This is accomplished by sending a repeating 8-bit pattern to the device. Different patterns set different functionalities.

Any pattern must be repeated a minimum of 128 times. The device is automatically muted when a pattern is detected so that a pattern can be set while the device is operational without a pop/click due to pattern transition. After this minimum repetition is complete, the pattern can be removed at any time and the device resumes normal operation.

All patterns except mute and power-down are sticky, in that after the pattern is sent the functionality of the pattern remains after the pattern is removed. Mute and power-down are active only when their respective patterns are being continuously written.

All functionality set via patterns return to its default values after a clock loss power-down or after the device reset pattern is sent.

Table 7. PDM Watermarking Pattern Control Descriptions

Pattern	Control Description	Register Setting
0xD2	Limiter: enable.	LIM_EN = 01
0xD4	Lower gain mode (3.6 V) with -6 dBFS).	ANA_GAIN = 0
0xD8	Shared clock operation. Only DAC_PDM_CLK is needed.	SHARED_CLOCK = 1
0xE1	Ultralow EMI mode.	Edges = 1
0xE2	Low latency mode with pattern delay (~15 μs latency).	LOW_LATENCY = 01
0xE4	Set DAC to low power mode = off. PDM_CLK = 128 × f _s mode.	DAC_LPM = 0
0xAA	Device reset: place the device into default configuration	
0x66	Mute.	DAC_MUTE = 1
0xAC	Power-down: all blocks off except for PDM interface. Normal start-up time.	SPWDN = 1
0xF1	Limiter: 3.7 V battery inflection point.	VBAT_INF = 010
0xF2	Limiter: 3.3 V battery inflection point.	VBAT_INF = 110
0xF4	Limiter: 2 V/V VBAT vs. the limiter slope.	Slope = 01
0xC1	Sense power-up/power-down toggle.	Toggle value of BSNS_PWDN, ISNS_PWDN, and VSNS_PTWN
0xC2	Limiter: threshold value set to 5.4 V peak.	LIM_THRES = 0110

PDM CHANNEL SELECTION

The *SSM4567* includes a left/right input select pin, LR_SEL/ADDR (see Table 24) that determines which of the time-multiplexed input streams is routed to the amplifier when using PDM pattern control mode. To select the left input channel, connect LR_SEL/ADDR pin to AGND. To select right channel data, connect LR_SEL/ADDR pin to IOVDD. At any point during amplifier operation, the logic level applied to LR_SEL/ADDR pin can be changed and the output switches between input streams without audible artifacts. Aside from logic level selection from the user, no muting, watermarking pattern, or synchronizing is necessary to achieve a click/pop free LR_SEL/ADDR transition.

Table 8. LR_SEL/ADDR Function Descriptions

Device Setting	LR_SEL/ADDR Pin Configuration
Right Channel Select	IOVDD
Left Channel Select	GND

PCM MODE PIN SETUP AND CONTROL

When the SEL pin is tied to IOVDD, the *SSM4567* is set for PCM mode operation. In this mode, the *SSM4567* supports standalone operation, I²C control, or can be controlled using commands sent over the input serial audio/TDM interface. When the LR_SEL/ADDR pin is pulled up via a 47 kΩ resistor, the IC operates in standalone mode with most registers set to their default states.

The state of the several pins can change the functionality of other pins. The LR_SEL/ADDR pin determines the I²C device address. In standalone and TDM control modes, the SCL and SDA pins are used to determine the TDM slot used. See Table 10 for details.

PCM DIGITAL AUDIO SERIAL INTERFACE

The *SSM4567* includes a standard serial audio interface that is slave only. The interface is capable of receiving and transmitting I²S, left justified, PCM, or TDM formatted data.

There is an input interface for sending audio to the amplifier and an output interface for the sense data. These interfaces share the same FSYNC and BCLK signals.

A BCLK signal must be provided to the *SSM4567* for correct operation. The BCLK signal must have a minimum frequency of 2 MHz. The BCLK signal is used for internal clocking of the device. The BCLK rate is automatically detected, but the sampling frequency must be known to the device. The BCLK rates at 32 kHz to 48 kHz that are supported are 50, 64, 100, 128, 192, 200, 256, 384, 400, and 512 times the sample rate.

The serial interfaces have three main operating modes. Stereo mode, typically I²S or left justified, is used when there is a single chip on the interface bus. TDM mode is more flexible and offers the ability to have multiple chips on the bus. The third operating mode is multichip I²S mode, which uses standard I²S formatting but allows multiple chips to use the bus.

It is also possible to use the serial interfaces for bidirectional control information. When this is done, the internal control registers are accessed via the serial audio interface and not from I²C.

These mode selections can be set via the I²C interface with the SAI_MODE and MC_I2S bits. Alternatively, in standalone mode or when AUTO_SAI is set to 1, the interface can auto-configure based on how the signals are connected to the clock pins and the FSYNC type (pulse or 50% duty cycle).

When in standalone or automatic configuration modes, an I²S interface format can be selected by swapping the pin connections for the BCLK and FSYNC signals (with the I²S LRCLK signal connected to the DAC/PDM_CLK/BCLK pin and BCLK signal connected to the SNS_PDM_CLK/FSYNC pin). When the BCLK and FSYNC signals are connected to their respective pins, and the FYSNC signal is a single BCLK cycle pulse, TDM mode is selected. When the BCLK and FSYNC signals are connected to their respective pins, and the FYSNC signal is a 50% duty cycle signal, multichip I²S mode is selected.

On the SNS_PDM_DAT/SNS_SDATAO pin, unused cycles can either be driven or set to high-Z. This is determined by the SAI_DRV control bit. If multiple chips are used on the serial interface bus, then SAI_DRV must be set to 0 so that unused cycles are not driven.

SERIAL DATA PLACEMENT

The *SSM4567* is flexible in where within a frame it places output data and where it looks for input data. There are four control bits for when input data is expected (Px_DAC) and six control bits for when output data is driven (Px_SNS).

A single data frame is broken up into individual fields, referred to as placements. Each placement can be 8 bits, 16 bits, or 24 bits in length. A single frame on the TDM or I²S data stream can contain several data placements of varying length.

When the serial port is operating in TDM mode, placements start directly after the FSYNC pulse. The first placement is referred to as P1, the second placement is referred to as P2, and so on, increasing sequentially. These placements appear in sequential order on the serial data signal. Up to four placements can be on the input stream and up to six placements can be on the output stream. Figure 37 shows a basic timing diagram of the placements in TDM mode.

When the serial port is operating in I²S mode, placements start directly after the FSYNC falling clock edge, signalling the beginning of a new frame. The first placement is referred to as P1, the second placement is referred to as P2, and so on, increasing sequentially. The odd-numbered placements (P1, P3, and P5) appear sequentially in the left channel, when the FSYNC signal is low (assuming FSYNC_MODE = 0), and the even-numbered placements (P2, P4, and P6) appear sequentially in the right channel, when the FSYNC signal is high (assuming that FSYNC_MODE = 0). Up to four placements can be on the input stream and up to six placements can be on the output stream.

Figure 38 shows a basic timing diagram of the placements in I²S mode.

The corresponding registers allow configuration of each data placement. An input placement (Px_DAC) can carry 24-bit audio data, 16-bit audio data, or eight zero bits that are used as padding and ignored. See the Right Justified Data section for more information about using the 8 zero bits settings. A sense placement (Px_SNS) can contain 16-bit voltage output data, 16-bit

current output data, 8-bit battery voltage data, 8-bit control data, alternating 16-bit voltage and current data, 8-bit status data, 8-bit V/I marker and slot ID data, or 8 zero bits.

For standard I²S mode, the serial input is configured to receive mono audio data, and the serial output is configured to send voltage, current, and battery data back to the host device. The corresponding registers are in Table 9 and the corresponding timing diagram is in Figure 39.

Table 9. Standard I²S Data Placement Settings

Register Bit Field	Setting	Description
BCLK_POL	0b0	Rising edge of BCLK is used to latch data
FSYNC_MODE	0b0	FSYNC low corresponds to left data channel
SDATA_FMT	0b0	Data MSB is delayed by one bit clock cycle
SAI_MODE	0b0	Stereo mode
MC_I2S	0b0	Normal I ² S operation
P1_DAC	0b00	24-bit audio input data is in input Placement P1
P1_SNS	0b000	16-bit sense voltage is in output Placement P1
P2_SNS	0b001	16-bit sense current is in output Placement P2
P3_SNS	0b010	8-bit battery voltage is in Placement P3

Table 10. PCM Modes Pin Setup List

Control Mode	I ² C Control Address ¹	TDM Slot	Signals Connected To Pins For Modes Listed In The First Three Columns					
			LR_SEL/ADDR	SCL	SDA	SEL	DAC_PDM_CLK/ BCLK	SNS_PDM_CLK/ FSYNC
I ² C	0 (0x34)	1	AGND	SCL	SDA	IOVDD	Bit clock	Frame sync
	1 (0x35)	2	IOVDD	SCL	SDA	IOVDD	Bit clock	Frame sync
	2 (0x36)	3	Open	SCL	SDA	IOVDD	Bit clock	Frame sync
Standalone (TDM Interface)	N/A	1	47 kΩ pull-up	AGND	AGND	IOVDD	Bit clock	Frame sync
	N/A	2	47 kΩ pull-up	AGND	IOVDD	IOVDD	Bit clock	Frame sync
	N/A	3	47 kΩ pull-up	IOVDD	AGND	IOVDD	Bit clock	Frame sync
	N/A	4	47 kΩ pull-up	IOVDD	IOVDD	IOVDD	Bit clock	Frame sync
Standalone (I ² S Interface)	N/A	N/A	47 kΩ pull-up	Boost power down (active low)	Shutdown (active low)	IOVDD	Frame sync (intentional swap of CLK pins, Pin B3 and Pin C1)	Bit clock (intentional swap of CLK pins, Pin B3 and Pin C1)
TDM	N/A	1	47 kΩ pull-down	AGND	AGND	IOVDD	Bit clock	Frame sync
	N/A	2	47 kΩ pull-down	AGND	IOVDD	IOVDD	Bit clock	Frame sync
	N/A	3	47 kΩ pull-down	IOVDD	AGND	IOVDD	Bit clock	Frame sync
	N/A	4	47 kΩ pull-down	IOVDD	IOVDD	IOVDD	Bit clock	Frame sync

¹ N/A means not applicable.

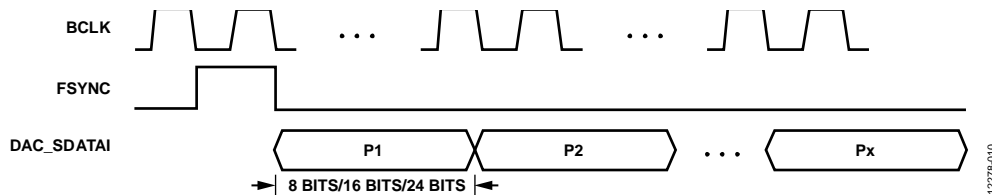

Figure 37. Basic Timing Diagram of Placements in TDM Stream

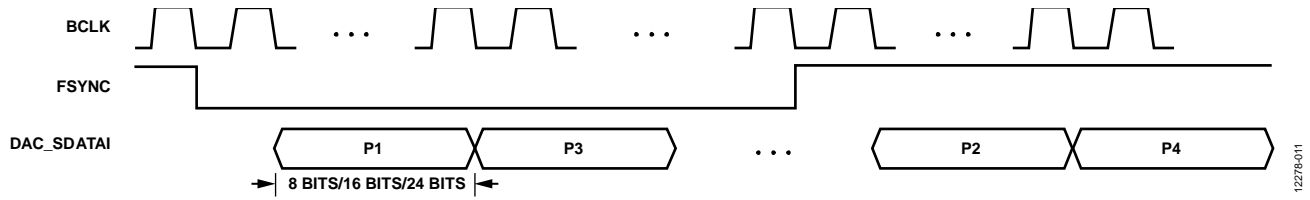

Figure 38. Basic Timing Diagram of Placements in I²S Stream

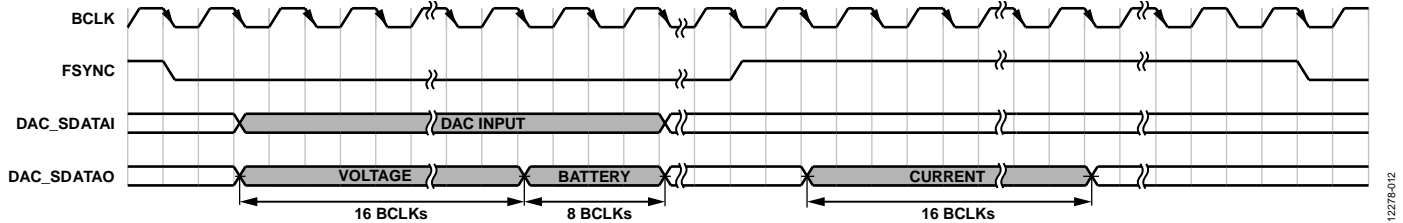

Figure 39. Standard I²S Data Placement Timing Diagram

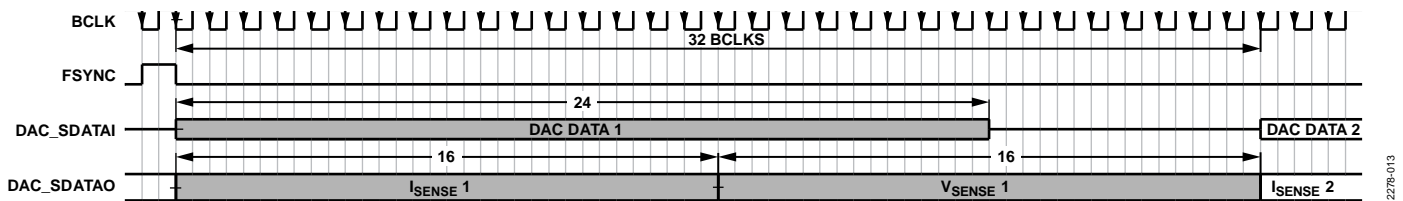

Figure 40. TDM Serial Interface Format

STEREO (I²S/LEFT JUSTIFIED) OPERATING MODE

Stereo modes use both edges of the FSYNC signal to determine placement of data. Stereo mode is enabled when SAI_MODE = 0 and I²S or left justified is determined by the SDATA_FMT bit setting. In standalone mode or when AUTO_SAI = 1, an I²S output interface can be configured by exchanging the connections to the DAC_PDM_CLK/BCLK and SNS_PDM_CLK/FSYNC pins. The I²S and left justified interface formats accept any number of BCLK cycles per FSYNC cycle. Sample rates from 8 kHz to 192 kHz are accepted.

The six placement control registers, SAI_PLACEMENT_x, determine placement of input and output data. Odd numbered placement control registers determine the order on the left channel and even number on the right channel. In the timing diagrams, these placements are referred to as P1 to P6. There are four placements for the incoming DAC data and six placements for the outgoing sense data.

RIGHT JUSTIFIED DATA

When the audio data in either a TDM or I²S slot placement is right justified, the Px_DAC bits can be used to properly read the data. Each Px_DAC bit has a setting where it reads in eight bits of data. The data is then not used and fulfills the read requirement for that slot so that the subsequent bits are read as the data of the next slot. This continues until a slot is reached that is set to read audio data.

For example, for a stereo I²S, 24-bit audio data-word that is right justified with 32 BCLKS for the left channel, set P1_DAC to b10 so that it picks up the first eight bits of zero data. Then, set P2_DAC to b00 so that it picks up the 24-bit audio data.

For another example, for a stereo I²S 16-bit audio data word that is right justified with 32 BCLKS for the left channel, set P1_DAC to b10 so that it picks up the first eight bits of zero data. Then, set P2_DAC to b10 so that it picks up the next blank 8 bits of data, and set P3_DAC to b01 so it then picks up the 16 bits of audio data.

TDM OPERATING MODE

TDM operating mode allows multiple chips to use a single serial interface bus.

The FSYNC signal on the SNS_PDM_CLK/FSYNC pin operates at the desired sample rate. The rising edge of the FSYNC signal indicates the start of a new frame. For proper operation, this signal must be one BCLK cycle wide, transitioning on a falling BCLK signal edge. The MSB of data is present on the SNS_PDM_DAT/SNS_SDATAO pin one BCLK cycle later. The SNS_PDM_DAT/ SNS_SDATAO signal must be latched on a rising edge of the BCLK signal (see Figure 40).

Each chip on the TDM bus can occupy 32, 48, or 64 BCLK cycles. This is set with the TDM_BCLKS control register and all chips on the bus must have the same setting. Up to eight SSM4567 chips can be used on a single TDM bus, but only three unique I²C device addresses are available. The SSM4567 automatically determines how many possible chips can be placed on the bus from the BCLK rate. There is no limit to the total number of BCLK cycles per FSYNC pulse. In standalone mode, only four slots can be used because there are only four combinations of the SDA and SCL pins to choose from (see Table 10).

When not in standalone mode, the slot that each SSM4567 uses is determined either by the LR_SEL/ADDR pin settings or the TDM_SLOT control register. By default, the setting is determined by the state of the LR_SEL/ADDR pin, which allows the first three slots to be selected. However, it can be overridden by the TDM_SLOT control register, which allows eight different slots to be selected.

Table 11. TDM Slot Selection

Device Setting	LR_SEL/ADDR Pin Configuration
TDM Chip 1 Slot Used/Driven	Tied to AGND
TDM Chip 2 Slot Used/Driven	Tied to IOVDD
TDM Chip 3 Slot Used/Driven	Open

The six placement control bits determine placement of input and output data within each chip slot. Input data to the DAC, using the DAC_PDM_DAT/DAC_SDATAI pin, can be either 16-bit or 24-bit data or it can be set to read in eight bits and ignore them. This is useful for right justified data formats where the first eight bits of the 32 bit clocks are padded zeros. The first placement register is set to read in eight bits and ignore them. Then the next placement register is set to read in the 24-bit audio data.

The output data from the DAC, using the SNS_PDM_DAT/SNS_SDATAO pin, can be any of the following:

- 16-bit voltage output
- 16-bit current output
- 8-bit battery (VBAT) voltage
- 8-bit control data output
- Alternating 16-bit voltage and current
- 8-bit status output
- 8-bit V/I marker and slot ID
- Blank eight bits

It is possible to have as many as six output placements and four input placements per frame depending on the clock rates.

MULTICHIP I²S OPERATING MODE

A special multichip I²S mode is enabled by setting the MC_I2S control register (Register 0x05[4]) to 1 when under I²C control. The TDM_SLOT register (Register 0x05[2:0]) sets the slot where data is expected and sense data is transmitted. In standalone mode or when AUTO_SAI = 1, multichip I²S is enabled when the device is wired for TDM mode (that is, the BCLK and

FSYNC signals are not swapped as they would be for I²S/left justified operation) except the FSYNC signal has a 50% duty cycle. The frequency of the FSYNC signal in relation to the BCLK signal determines if the device is in two-chip or four-chip mode. If the FSYNC signal consists of one BCLK cycle pulse, TDM operating mode is active instead.

The multichip I²S interface allows multiple chips to drive a single I²S bus. Each chip takes control of the bus every two or four frames (depending on the number of chips placed on the bus), allowing a maximum of four chips on the bus. Each frame or cycle of the FSYNC signal must 64 BCLK cycles long. The LR_SEL/ADDR pin assignments determine the order of control. Each frame also contains a slot ID code that is appended to the current data in the frame. This code indicates the slot of the chip that sent the data for that frame.

The mapping of LR_SEL/ADDR pin assignments to the ID tag when not in standalone mode is shown in Table 12.

Table 12. Multichip I²S Slot Configuration in SA Mode

ADDR Pin Configuration	Slot No.	ID Tag
Tied to AGND	1	0001
Tied to IOVDD	2	0010
Open	3	0100

The device automatically configures for two-chip or four-chip depending on the number of detected chips in the bus. For two-chip operation, the first and second slots must be used. Unused slots are allowed; however, Slot 1 must always be used. To enable two-chip operation, the device starts in four-chip operation and, when it is detected that Slot 3 and Slot 4 are unused, it switches to two-chip operation.

Table 13 describes the FSYNC and BCLK rates that are supported in multichip I²S mode.

Table 13. FSYNC and BCLK Rates For Multichip I²S

Sample Rate	Valid Slots	FSYNC Rate	BCLK Rate
32 kHz to 48 kHz	1, 2	2 × f _s (32 kHz to 96 kHz)	128 × f _s (2.048 MHz to 6.144 MHz)
32 kHz to 48 kHz	1, 2, 3, 4	4 × f _s (64 kHz to 128 kHz)	256 × f _s (4.096 MHz to 12.288 MHz)

SYSTEM GAIN

The default analog gain of the SSM4567 maps a 0 dBFS input level to 5.1 V peak nominally at the amplifier output. This setting provides optimal gain staging for best noise performance.

A lower analog gain setting that maps a 0 dBFS input level to 3.6 V peak can be set via the ANA_GAIN bit, Register 0x01[0].

There is also digital gain/volume control, Register 0x03, that provides fine control in 0.375 dB steps from -71.25 dB to +24 dB. There is one additional step for mute.

OUTPUT CURRENT SENSING

The SSM4567 uses an on-chip sense resistor to determine the output current flowing to the load. The voltage across this sense resistor is proportional to the load current and sent to an ADC running nominally at $128 \times f_s$. In PCM mode, the output of this ADC is downsampled using digital filtering. This downsampled signal at an 8 kHz to 192 kHz sample rate is output on the digital audio interface. The data is 16 bits and in signed fraction format. For both current and voltage sensing a sample rate equal to the DAC input is the default setting. A lower sample rate of $\frac{1}{2}$, $\frac{1}{4}$, or $\frac{1}{8}$ the DAC sample rate can be used. This can be set using the SNS_FS bits, Register 0x01[5:4].

In PDM mode the sense ADC runs at the PDM clock rate.

OUTPUT VOLTAGE SENSING

The output voltage level is monitored and sent to an ADC running nominally at $128 \times f_s$. The output of this ADC is then downsampled using digital filtering. This downsampled signal at 8 kHz to 192 kHz sample rate is output on the digital audio interface. The data is 16 bits and in signed fraction format. For both current and voltage sensing, a sample rate equal to the DAC input is the default setting. A lower sample rate of $\frac{1}{2}$, $\frac{1}{4}$, or $\frac{1}{8}$ the DAC sample rate can be used. This can be set using the SNS_FS bits, Register 0x01[5:4].

In PDM mode, the sense ADC runs at the PDM clock rate.

VBAT SENSING

The SSM4567 contains an 8-bit ADC that measures the voltage of the VBAT supply in real time. The output of the ADC is in 8-bit unsigned format and is presented on the eight MSBs of the 16 bits in Slot 3 on the TDM bus. The remaining eight LSBs are driven low (see Figure 39).

LIMITER AND BATTERY TRACKING THRESHOLD CONTROL

The SSM4567 contains an output limiter that can limit the peak output voltage of the amplifier. The threshold at which the output is limited is determined by the LIM_THRES register setting, Register 0x0E[3:0]. The audio signal is not affected by the limiter function unless the peak audio output voltage exceeds the limiter threshold level.

The LIM_THRES can be set above the maximum output voltage of the amplifier. In this case, the limiter allows maximum peak output, but limits the amount of clipping that can occur. The rate of gain reduction or attack rate and gain increase or release rate is determined by the LIM_ATR bits (Register 0x0E[5:4]) and LIM_RRT bit (Register 0x0E[7:6]), respectively.

The SSM4567 can monitor the VBAT supply and automatically adjust the limiter threshold when the VBAT supply is below a selected point when LIM_EN = 01. When using the limiter, it can be selected whether the threshold is fixed or moves with the battery voltage via the VBAT_TRACK bit (Register 0x0D[2]). This function can prevent early shutdown under end-of-charge battery conditions. The VBAT supply voltage at which the limiter

level begins to decrease the output level is determined by the VBAT_INF bits (Register 0x0D[5:3]). The rate at which the threshold is lowered relative to the amount VBAT has lowered below the VBAT_INF point is determined by the slope bits (Register 0x0D[7:6]).

The limiter can also be set such that it engage only when the battery voltage is lower than VBAT_INF by setting LIM_EN = 11. When VBAT is above VBAT_INF, no limiting takes place. In this case, there is hysteresis on VBAT_INF for the limiter disengaging. If LIM_EN = 10, when VBAT falls below the VBAT_INF value, the amplifier automatically mutes. In this case, there is hysteresis on VBAT_INF when the mute is disengaged.

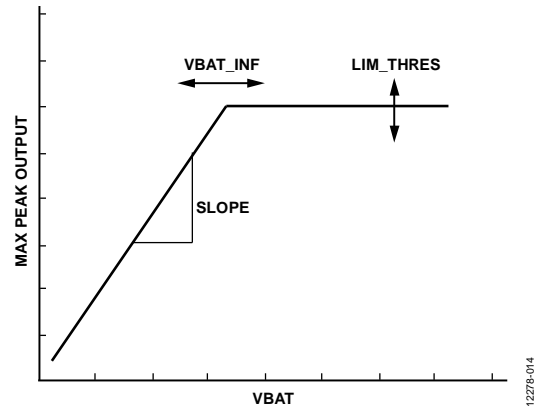

Figure 41. Battery Tracking Limiter Threshold Control

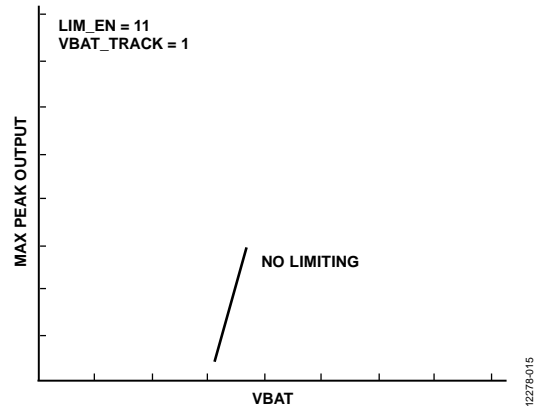

Figure 42. Limiter Example (LIM_EN = 0b11, VBAT_TRACK = 0b1)

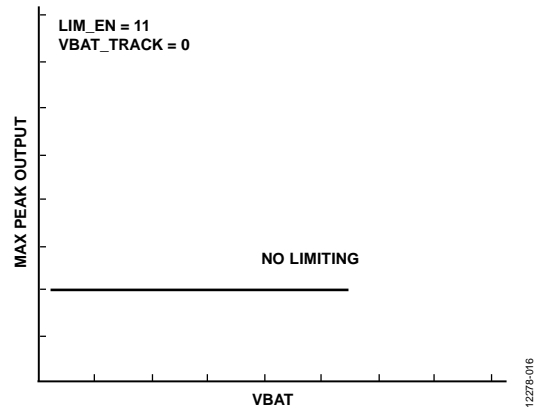

Figure 43. Limiter Example (LIM_EN = 0b11, VBAT_TRACK = 0)

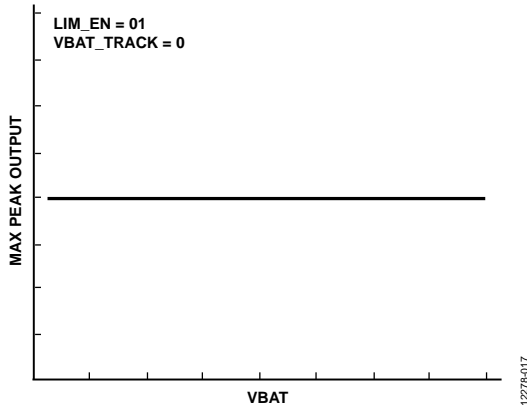

Figure 44. Limiter Example (LIM_EN = 0b01, VBAT_TRACK = 0)

I²C CONTROL

The **SSM4567** supports a 2-wire, serial, I²C-compatible microprocessor bus driving multiple peripherals. Two pins, serial data (SDA) and serial clock (SCL), carry information between the **SSM4567** and the system I²C master controller. The **SSM4567** is always a slave on the bus, meaning it cannot initiate a data transfer. Each slave device is recognized by a unique address. The address byte format is shown in Table 14. The address resides in the first seven bits of the I²C write. The LSB of this byte sets either a read or write operation. Logic Level 1 corresponds to a read operation, and Logic Level 0 corresponds to a write operation.

Both SDA and SCL need 2.2 k Ω pull-up resistors for proper operation. Only one set of pull-up resistors are required for the entire I²C bus. The voltage on these signal lines must not be more than 3.3 V.

Table 14. I²C Chip Address Byte Format

Bit 0	Bit 1	Bit 2	Bit 3	Bit 4	Bit 5	Bit 6	Bit 7
0	1	1	0	1	I ² C Addr. MSB	I ² C Addr. LSB	R/W

Table 15. I²C Device Address Selection

Device Address (7-Bit Format)	Device Address (8-Bit Format)	LR_SEL/ADDR Pin Configuration
0x34	0x68	Tied to AGND
0x35	0x6A	Tied to IOVDD
0x36	0x6C	Open

Addressing

Initially, each device on the I²C bus is in an idle state, monitoring the SDA and SCL lines for a start condition and the proper address. The I²C master initiates a data transfer by establishing a start condition, defined by a high-to-low transition on SDA while SCL remains high. This indicates that an address/data stream follows. All devices on the bus respond to the start condition and shift the next eight bits (the 7-bit address plus the R/W bit) MSB first. The device that recognizes the transmitted address responds by pulling the data line low during the ninth clock

pulse. The device address of the **SSM4567** is determined by the state of the LR_SEL/ADDR pin. When the LR_SEL/ADDR pin is pulled to ground, the device address is 0x34.

This ninth bit is known as an acknowledge bit. All other devices withdraw from the bus at this point and return to the idle condition. The R/W bit determines the direction of the data. A Logic 0 on the LSB of the first byte means the master writes information to the peripheral, whereas a Logic 1 means the master reads information from the peripheral after writing the subaddress and repeating the start address. A data transfer takes place until a stop condition is encountered. A stop condition occurs when SDA transitions from low to high while SCL is held high. The timing for the I²C port is shown in Figure 45.

Stop and start conditions can be detected at any stage during the data transfer. If these conditions are asserted out of sequence with normal read and write operations, the **SSM4567** immediately jumps to the idle condition. During a given SCL high period, the user must issue only one start condition, one stop condition, or a single stop condition followed by a single start condition. If an invalid subaddress is issued by the user, the **SSM4567** does not issue an acknowledge and returns to the idle condition. If the user exceeds the highest subaddress while in auto-increment mode, one of two actions is taken. In read mode, the **SSM4567** outputs the highest subaddress register contents until the master device issues a no acknowledge, indicating the end of a read. A no acknowledge condition is where the SDA line is not pulled low on the ninth clock pulse on SCL. If the highest subaddress location is reached while in write mode, the data for the invalid byte is not loaded into any subaddress register, a no acknowledge is issued by the **SSM4567**, and the device returns to the idle condition.

I²C Read and Write Operations

Figure 46 shows the format of a single-word write operation. Every ninth clock, the **SSM4567** issues an acknowledge message by pulling SDA low.

Figure 47 shows the format of a burst mode write sequence. This figure shows an example where the target destination registers are two bytes. The **SSM4567** knows to increment its subaddress register every byte because the requested subaddress corresponds to a register or memory area with a byte word length.

The timing of a single-word read operation is shown in Figure 48. Note that the first R/W bit is 0, indicating a write operation. This is because the subaddress still must be written to set up the internal address. After the **SSM4567** acknowledges the receipt of the subaddress, the master must issue a repeated start $\overline{\text{start}}$ command, followed by the chip address byte with the R/W set to 1 (read). This causes the **SSM4567** SDA to reverse and begin driving data back to the master. The master then responds every ninth pulse with an acknowledge pulse to the **SSM4567**.

Table 16. List of Abbreviations Used in I²C Timing Figures, Figure 46 to Figure 49

Symbol	Meaning
S	Start bit
P	Stop bit
A _M	Acknowledge by master
A _S	Acknowledge by slave

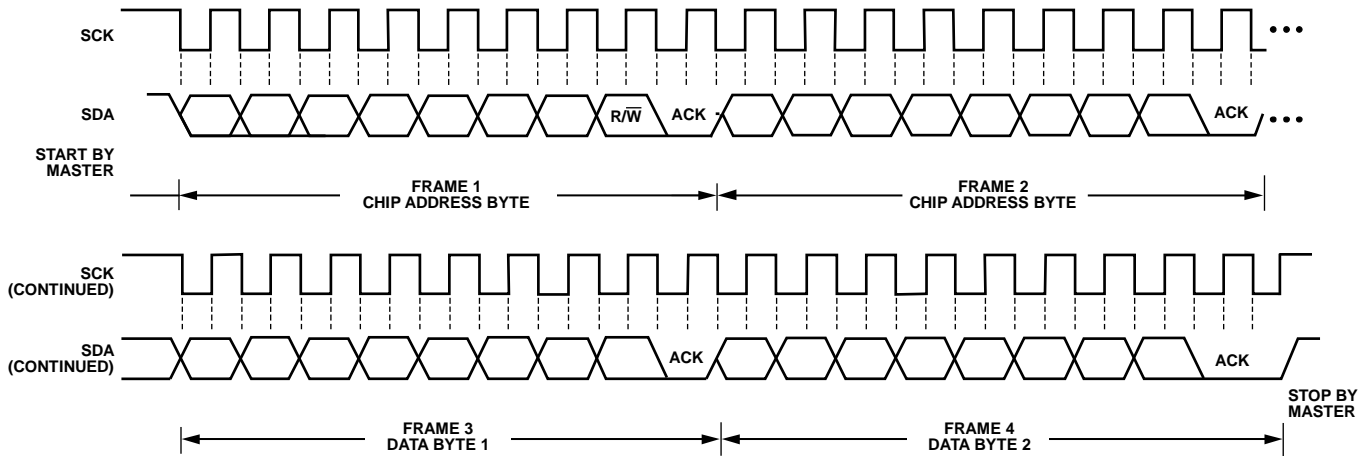

Figure 45. I²C Read/Write Timing

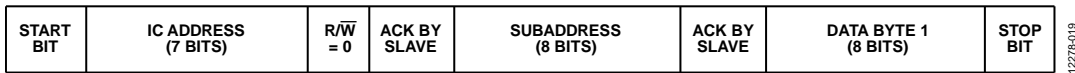

Figure 46. Single-Word I²C Write Format

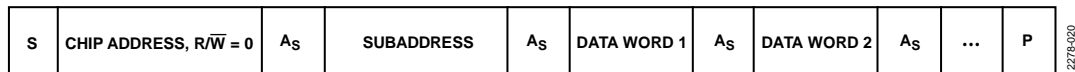

Figure 47. Burst Mode I²C Write Format

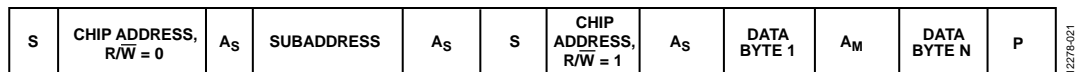

Figure 48. Single-Word I²C Read Format

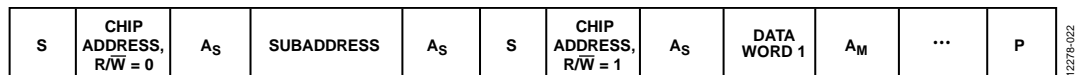

Figure 49. Burst Mode I²C Read Format

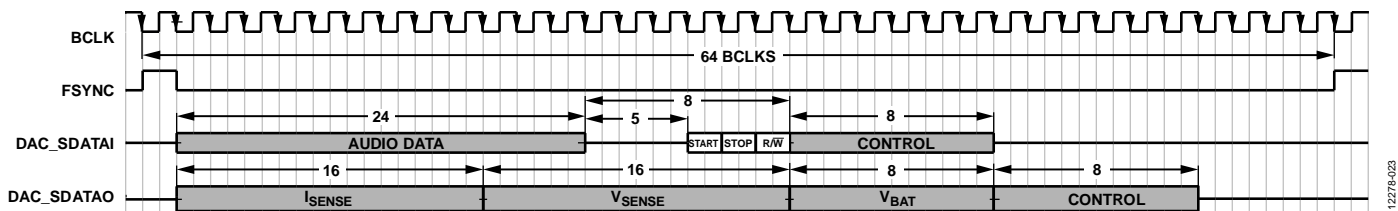

Figure 50. TDM Control Format

TDM CONTROL INTERFACE

The *SSM4567* supports control data sent over the serial audio interface (SAI). This allows flexible control of the device without requiring an I²C control port connection. Only TDM operation with 64 BCLKs per chip is supported in this mode (see Figure 50). It is not possible to modify any of the SAI control registers in this mode. The placement for DAC inputs, Px_DAC, also cannot be modified. The placements for sense outputs, Px_SNS, can be modified. An 8-bit control data output can be placed on the SNS_PDM_DAT/SNS_SDATAO line via the placement register. This allows reading of control data over the SAI. It is not necessary to use this in SAI control mode.

P1	P2	P3	P4
DAC 24-BIT	CONTROL HEADER 8-BIT	CONTROL DATA 8-BIT	BLANK

12776/024

Figure 51. SDAI Data Placement for SAI Control, TDM with 64-Bit Slot

Two bytes, the control header and control data, must be placed in the DAC input stream and one byte, control data, is placed on the output sense stream.

The three LSBs of the control header byte are used to initiate control sequences. They are the start bit indicating the start of a control sequence when set to one, the stop bit indicating the stop of a control sequence when set to one, and the read/write bit, which indicates a read or write sequence when the start bit is also set.

BIT 0	BIT 1	BIT 2	BIT 3	BIT 4	BIT 5	BIT 6	BIT 7
0	0	0	0	0	START	STOP	R/W

026/024

Figure 52. SAI Control Header Byte Format

The control data sequencing is the same as I²C control, except a device address is not required. The first control data byte sent after the start is the 8-bit subaddress; the subsequent control data bytes are data.

Table 17. SAI Control Write Sequence

Frame	Control Header	Control DAC_DATAI	Control SNS_DATAO
1	0x04	Subaddress	0x00
2	0x00	Data 1	0x00
3	0x00	Data 2	0x00
4	0x00	Data 3	0x00
5	0x02	Don't care	0x00

Table 18. SAI Control Read Sequence

Frame	Control Header	Control DAC_DATAI	Control SNS_DATAO
1	0x05	Subaddress	0x00
2	0x00	Don't care	Data 1
3	0x00	Don't care	Data 2
4	0x00	Don't care	Data 3
5	0x02	Don't care	0x00

STANDALONE MODE CONTROL

The *SSM4567* can be operated without any control interface in standalone mode. This mode is set by pulling up the LR_SEL/ADDR pin to IOVDD with a 47 kΩ resistor. When operating in standalone mode, all control settings are set to their default state except for those listed in Table 19.

Table 19. Non Default Register Settings in Standalone Mode

Bit Name	SA_MODE Setting	Function
SPWDN	0	Normal operation
AUTO_SAI	1	Auto detection of serial audio interface format
LIM_EN	00	Disable limiter
SDATA_FMT	0	Normal I ² S
TDM_BCLKS	10	64 BCLKs per chip in TDM
PDM_MODE	b0	Disable PDM mode

In standalone mode with the interface set to TDM mode, the SDA pin and the SCL pin are used to select the TDM/channel slot. If in I²S mode, the SCL pin can be used to power down boost, and the SDA pin can be used to shut down the whole device (see Table 10).

EMI NOISE

The *SSM4567* uses a proprietary modulation and spread-spectrum technology to minimize EMI emissions from the device. The *SSM4567* can pass FCC Class B emissions testing with unshielded 20-inch cable using ferrite bead-based filtering. For applications that have difficulty passing FCC Class B emission tests, the *SSM4567* includes an edge rate control bit, Register 0x01[2] (ultralow EMI emission mode), that significantly reduces the radiated emissions at the Class-D outputs, particularly above 100 MHz. Note that reducing the supply voltage also greatly reduces radiated emissions.

OUTPUT MODULATION DESCRIPTION

The *SSM4567* uses five-level, Σ-Δ output modulation. Each output can swing from PGND to VBAT or PGND to VBST at any time and vice versa. Ideally, when no input signal is present, the output differential voltage is 0 V, because there is no need to generate a pulse. In a real-world situations, there are always noise sources present.

Due to this constant presence of noise, a differential pulse is generated, when required, in response to this stimulus. A small amount of current flows into the inductive load when the differential pulse is generated.

Most of the time, however, output differential voltage is 0 V, due to the Analog Devices, Inc., five-level, Σ-Δ output modulation. This feature ensures that the current flowing through the inductive load is small.

When high output is not needed, ensure no efficiency loss due to the extra boost switch by switching off the battery supply.

With variable boost methods after high output is no longer needed, the boost remains on for a long time. With five-level modulation, it instantly switches back to using the battery supply, resulting in better real-world power. Figure 53 depicts five-level, Σ - Δ output modulation with input stimulus.

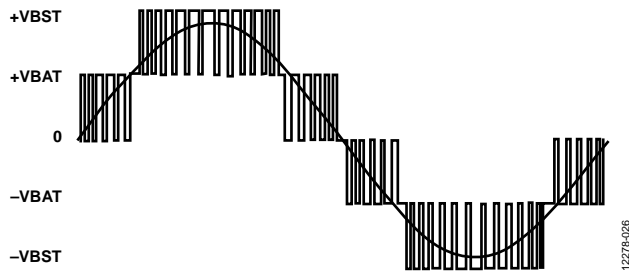

Figure 53. Five-Level, Σ - Δ Output Modulation

INTEGRATED BOOST CONVERTER

An integrated boost converter is provided with a nominal switching frequency of 1.536 MHz. The converter is designed to step up the VBAT supply, typically 3.6 V from a single-cell battery, to a higher V_{OUT} voltage of 5.1 V. The output of the boost converter is available at the VBST pins. A 2.2 μ H inductor is required for proper operation of the boost converter. See the Component Selection for Boost Regulators section for more details on selecting the proper inductor. The boost converter can be powered down via the BOOST_PWDN control bit. When the boost is powered down and the amplifier is still active, the amplifier runs directly off the VBAT supply. This same VBAT only operation can be entered with the boost still active with the VBAT_ONLY bit. The amplifier can be powered down with the boost still enabled so that the boost output can be used for other functions.

APPLICATIONS INFORMATION

COMPONENT SELECTION FOR BOOST REGULATORS

Inductor Selection

The inductor is an essential part of the boost regulator. It stores energy during on time of the low-side power FET in the boost regulator. It is during this time that the input current is at its maximum. The maximum input current must be taken into account to determine the inductor value. The maximum dc input current (that is, the maximum average inductor current) can be estimated by using the following equation:

$$I_{IN} = I_{LOAD(MAX)} \times \left(\frac{V_{OUT}}{V_{IN}} \right) \times \frac{1}{\eta}$$

where $\eta \approx 85\%$.

The desired input and output voltages, the switching frequency, and the ripple current determine the required inductor value, as shown in the following equation:

$$L = \frac{V_{OUT} - V_{IN}}{I_{RIPPLE}} \times \frac{1}{f_{SW}} \times \frac{V_{IN}}{V_{OUT}}$$

In general, the ripple current is estimated as 30% of the maximum dc input current (I_{IN}), so the equation can be rewritten as follows:

$$L = \frac{V_{OUT} - V_{IN}}{0.3 \times I_{IN}} \times \frac{1}{f_{SW}} \times \frac{V_{IN}}{V_{OUT}}$$

The maximum rated current of the inductor should be greater than the peak inductor current (I_{PEAK}). If the margin of these currents is not enough, the inductor may be saturated due to inductor value degradation, causing it to hit the current limit, even in a lower load condition than expected.

The peak inductor current can be estimated as following:

$$I_{PEAK} = I_{IN} + \frac{I_{RIPPLE}}{2} = I_{IN} + 0.15 \times I_{IN} = 1.15 \times I_{IN}$$

Another important specification to be considered is the parasitic series resistance in the inductor: dc resistance (DCR). A larger DCR may decrease efficiency performance, but a larger inductor size has smaller DCR; therefore, the tradeoff between available space on the PCB and device performance should be considered carefully. The recommended inductors are shown in Table 20.

Output Capacitor Selection

The output capacitor maintains the output voltage and supplies current to the load while the regulator switch is on. The value and characteristics of the output capacitor significantly affect the output voltage ripple and stability of the regulator. Use a low ESR output capacitor; ceramic dielectric capacitors are preferable.

For very low ESR capacitors, such as ceramic capacitors, the ripple current due to the capacitance is calculated as follows. In continuous mode, because the capacitor discharges during the on time (t_{ON}), the charge removed from the capacitor (Q_C) is the load current multiplied by the on time.

Therefore, the output voltage ripple (ΔV_{OUT}) is

$$\Delta V_{OUT} = \frac{Q_C}{C_{OUT}} = \frac{I_L \times t_{ON}}{C_{OUT}}$$

where:

C_{OUT} is the output capacitance.

I_L is the average inductor current.

Using the duty cycle (D) and switching frequency (f_{SW}), users can determine the on time by using the following equation:

$$t_{ON} = \frac{D}{f_{SW}}$$

The input (V_{IN}) and output (V_{OUT}) voltages determine the switch duty cycle (D) by using the following equation:

$$D = \frac{V_{OUT} - V_{IN}}{V_{OUT}}$$

Choose the output capacitor based on the following equation:

$$C_{OUT} \geq \frac{I_L \times (V_{OUT} - V_{IN})}{f_{SW} \times V_{OUT} \times \Delta V_{OUT}}$$

The minimum output capacitor required is a 10 μ F, X5R capacitor; however, to maintain stability across the entire operating range and with component variations, one 22 μ F, X5R capacitor is recommended.

LAYOUT

As output power increases, lay out PCB traces and wires properly among the amplifier, load, and power supply; a poor layout increases voltage drops, consequently decreasing efficiency. A good practice is to use short, wide PCB tracks to decrease voltage drops and minimize inductance. It is also important to minimize the use of vias for signal lines with fast edges on the data transitions. In addition, do not place vias between the small value decoupling capacitors and the pin. Connect the vias to the ground or power planes on the far side of the capacitor from the perspective of the pin.

POWER SUPPLY DECOUPLING

To ensure high efficiency, low total harmonic distortion (THD) and high PSRR, proper power supply decoupling is necessary. Noise transients on the power supply lines are short duration voltage spikes. These spikes can contain frequency components that extend into the hundreds of megahertz. Both the battery supply and internally generated VBST must be decoupled with a good quality, low ESL, low ESR capacitor, with a minimum

value of 10 μF . This capacitor bypasses low frequency noises to the ground plane. For high frequency transient noises, use a 1 μF capacitor as close as possible to the VBAT and VBST pins of the device. If possible, avoid vias between the pins of the capacitor and the pin of the device. Placing the decoupling capacitors as close as possible to the [SSM4567](#) helps to maintain good performance.

Table 20. Suggested Inductors

Part No.	Manufacturer	Value (μH)	Rated Current (mA)	DCR (Ω)	Size (mm)
IFSC1008ABER2R2M01	Vishay Dale	2.2	1850	0.09	2.50 × 2.00 × 1.20
IFSC1111ABER2R2M01	Vishay Dale	2.2	1900	0.098	2.90 × 2.90 × 1.20
MAMK2520T2R2M	Taiyo Yuden	2.2	1900	0.117	2.50 × 2.00 × 1.20
L1210R2R2MDWIT	Kemet	2.2	2000	0.08	3.20 × 2.49 × 2.49
LQM2HPN2R2MGHL	Murata	2.2	1500	0.110	2.5 × 2.00 × 0.90

TYPICAL APPLICATION CIRCUITS

SOFTWARE CONTROL MODE, I²S/TDM INTERFACE

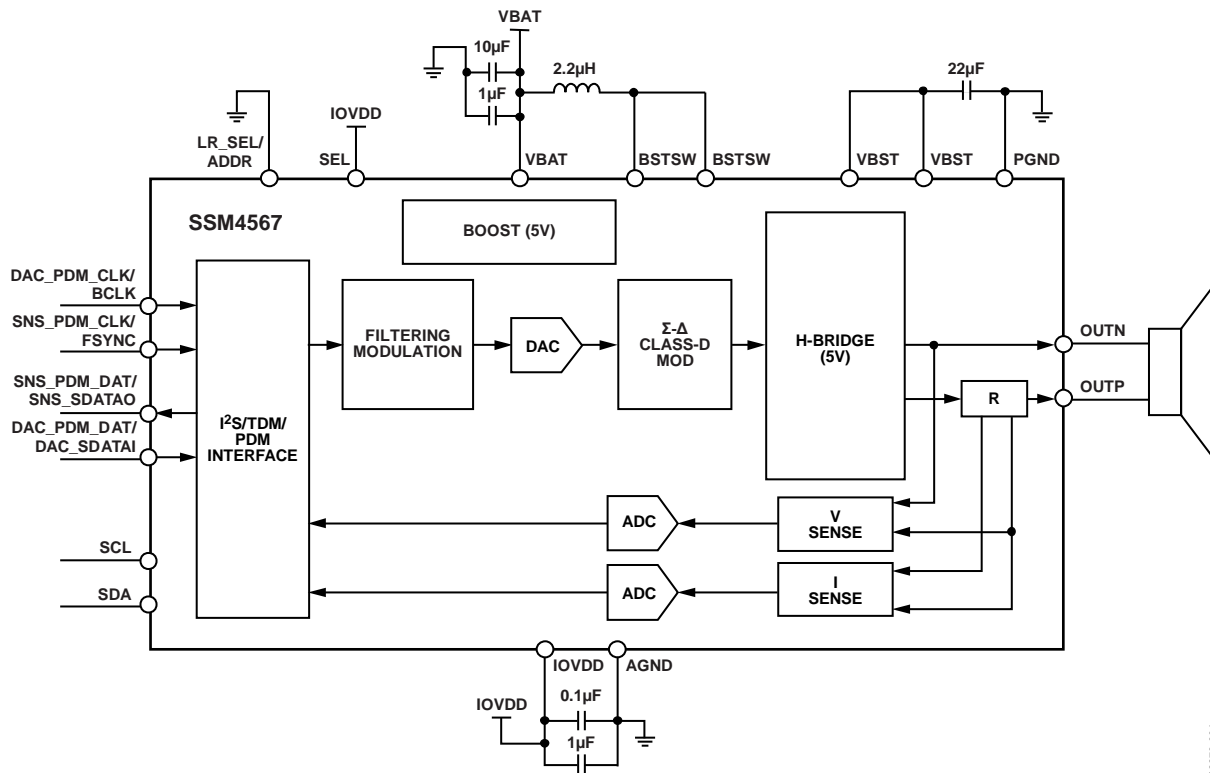

Figure 54. Typical Application Circuit, I²S, Software Control Mode

12278-004

Description

In this application circuit, the **SSM4567** is controlled by an external master on the I²C interface. The I²C address is configured using the LR_SEL/ADDR pin. The serial data interface is in PCM mode, as configured by the SEL pin.

Pin Configuration

Table 21. Pin Configuration for I²S Software Control Applications, Software Control Mode, I²S/TDM Interface

Hardware Pin	Connection
LR_SEL/ADDR	Connect to AGND for I ² C Address 0x34; IOVDD for I ² C Address 0x35; leave open for I ² C Address 0x36.
SEL	Connect to IOVDD for PCM mode.
SNS_PDM_CLK/FSYNC	Connect to an external I ² S/TDM frame sync clock signal.
DAC_PDM_CLK/BCLK	Connect to an external I ² S/TDM bit clock signal.
SNS_PDM_DAT/SNS_SDATAO	Sends current, voltage, and battery sense data in I ² S/TDM format to an external IC.
DAC_PDM_DAT/DAC_SDATAI	Receives a serial audio data signal in I ² S/TDM format from an external IC.
SCL	Connect to the clock signal of an external I ² C master IC.
SDA	Connect to data signal of an external I ² C master IC.

SOFTWARE CONTROL MODE, PDM INTERFACE

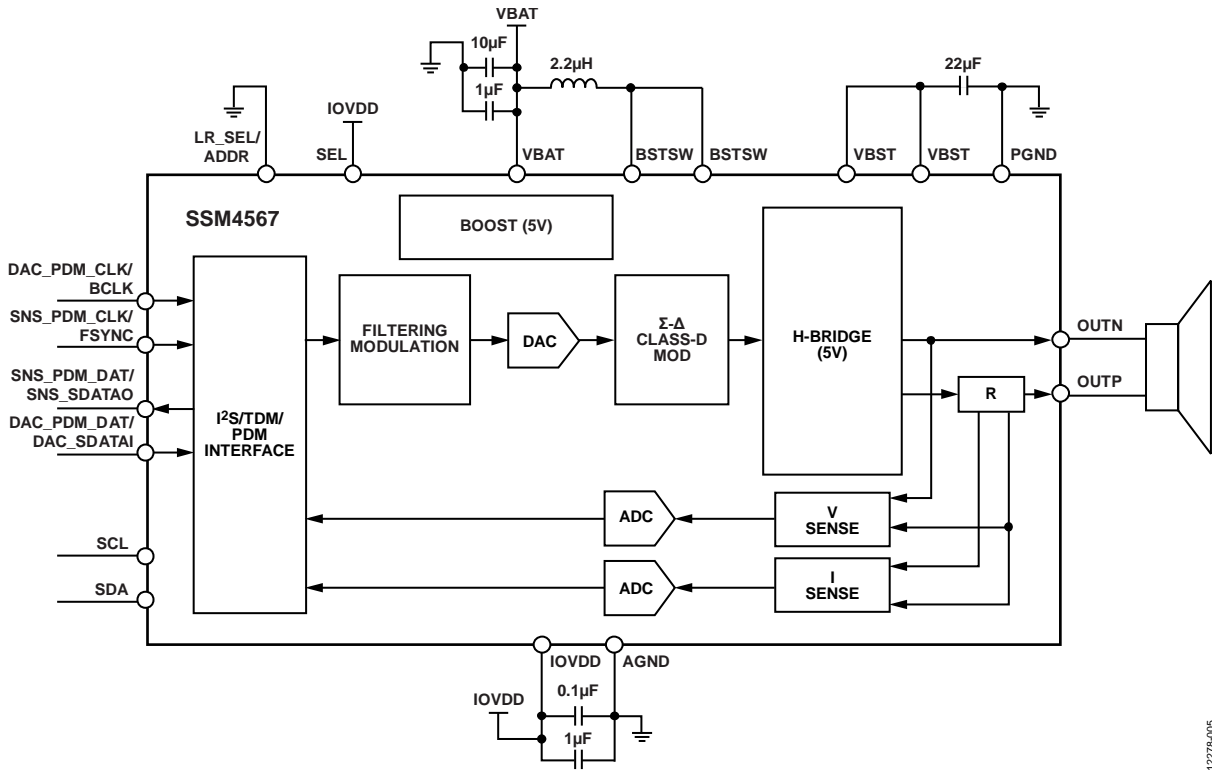

Figure 55. Typical Application Circuit, PDM, Software Control Mode

12278-005

Description

In this application circuit, the SSM4567 is controlled by an external master on the I²C interface. The I²C address is configured using the LR_SEL/ADDR pin. The serial data interface is initially set to PCM mode, as configured by the SEL pin, but must be changed to PDM mode using register writes when configuring the device via I²C.

Pin Configuration

Table 22. Pin Configuration for I²S Software Control Applications, Software Control Mode, PDM Interface

Hardware Pin	Connection
LR_SEL/ADDR	Connect to AGND for I²C Address 0x34; IOVDD for I²C Address 0x35; leave open for I²C Address 0x36.
SEL	Connect to IOVDD for I²C control mode.
SNS_PDM_CLK/FSYNC	Connect to an external PDM clock signal for sense data.
DAC_PDM_CLK/BCLK	Connect to an external PDM clock signal for audio data.
SNS_PDM_DAT/SNS_SDATAO	Sends current, voltage, and battery sense data in PDM format to an external IC.
DAC_PDM_DAT/DAC_SDATAI	Receives a serial audio data signal in PDM format from an external IC.
SCL	Connect to the clock signal of an external I²C master IC.
SDA	Connect to data signal of an external I²C master IC.

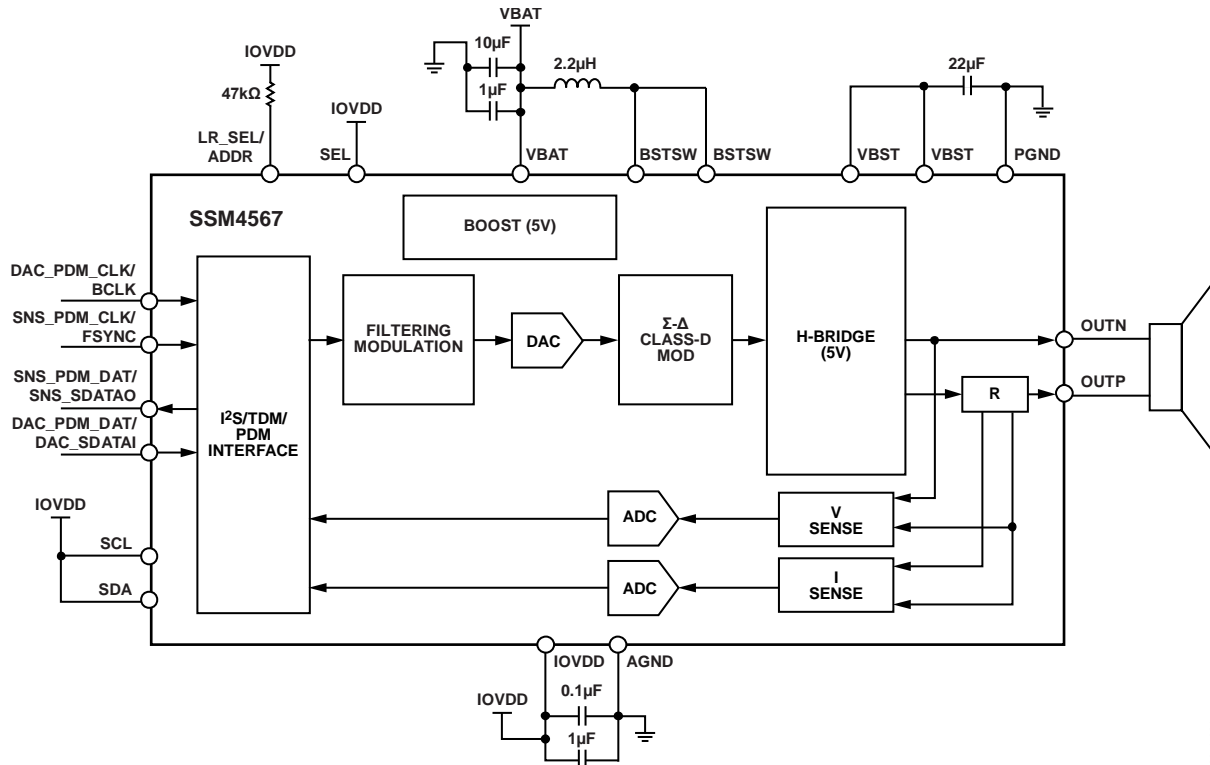
STANDALONE MODE, I²S/TDM INTERFACEFigure 56. Typical Application Circuit, I²S, Standalone Mode

12278-006

Description

In this application circuit, the SSM4567 operates in standalone mode, without an I²C master in the system. The I²C address is configured using the LR_SEL/ADDR pin. The serial data interface is in PCM mode, as configured by the SEL pin.

Pin ConfigurationTable 23. Pin Configuration for I²S Software Control Applications, Standalone Mode, I²S/TDM Interface

Hardware Pin	Connection
LR_SEL/ADDR	Pull up to IOVDD with a 47 kΩ resistor to enable standalone mode.
SEL	Connect to IOVDD for PCM mode.
SNS_PDM_CLK/FSYNC	Connect to an external I ² S/TDM frame sync clock signal.
DAC_PDM_CLK/BCLK	Connect to an external I ² S/TDM bit clock signal.
SNS_PDM_DAT/SNS_SDATAO	Sends current, voltage, and battery sense data in I ² S/TDM format to an external IC.
DAC_PDM_DAT/DAC_SDATAI	Receives a serial audio data signal in I ² S/TDM format from an external IC.
SCL	Connect to either IOVDD or AGND to select which I ² S/TDM audio data slot is sent to the amplifier (see Table 10).
SDA	Connect to either IOVDD or AGND to select which I ² S/TDM audio data slot is sent to the amplifier (see Table 10).

PATTERN CONTROL MODE, PDM INTERFACE

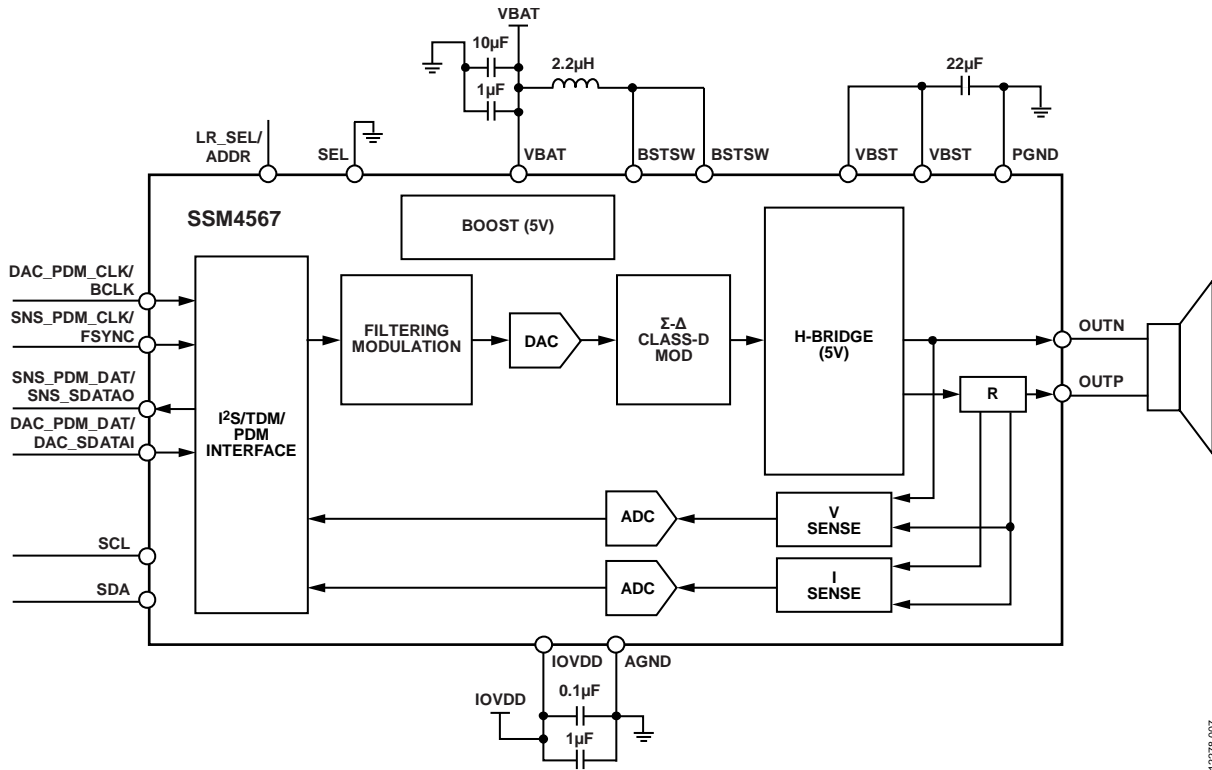

Figure 57. Typical Application Circuit, PDM, Pattern Control Mode

12278-007

Description

In this application circuit, the [SSM4567](#) is configured directly over the PDM interface, which is where it also receives audio data for playback and outputs sense information back to the host device. This mode is configured by connecting the SEL pin to AGND when the device is powered up. Optionally, the I²C pins can be left disconnected. The audio channel is selected by the state of the LR_SEL pin.

Pin Configuration

Table 24. Pin Configuration for PDM Pattern Mode Control Applications, Pattern Control Mode, PDM Interface

Hardware Pin	Connection
LR_SEL/ADDR	Connect to AGND to output the left PDM channel; connect to IOVDD to output the right PDM channel.
SEL	Connect to AGND to start in PDM mode.
SNS_PDM_CLK/FSYNC	Connect to an external PDM sense clock signal.
DAC_PDM_CLK/BCLK	Connect to an external PDM audio clock signal.
SNS_PDM_DAT/SNS_SDATA0	Sends current, voltage, and battery sense data in PDM format to an external IC.
DAC_PDM_DAT/DAC_SDATA1	Receives a serial audio data signal in PDM format from an external IC.
SCL	Leave disconnected if I²C control is not needed; connect to SCL signal if I²C control is required.
SDA	Leave disconnected if I²C control is not needed; connect to SDA signal if I²C control is required.

REGISTER SUMMARY

Table 25. REG_MAP Register Summary

Reg	Name	Bits	Bit 7	Bit 6	Bit 5	Bit 4	Bit 3	Bit 2	Bit 1	Bit 0	Reset	RW	
0x00	POWER_CTRL	[7:0]	APWDN_EN	BSNS_PWDN	VSNS_PWDN	ISNS_PWDN	BOOST_PWDN	AMP_PWDN	VBAT_ONLY	SPWDN	0x81	R/W	
0x01	AMP_SNS_CTRL	[7:0]	RESERVED		SNS_FS		SNS_HPF	EDGES	RESERVED	ANA_GAIN	0x09	R/W	
0x02	DAC_CTRL	[7:0]	DAC_HV	DAC_MUTE	DAC_HPF	DAC_LPM	RESERVED	DAC_FS			0x32	R/W	
0x03	DAC_VOLUME	[7:0]	VOL									0x40	R/W
0x04	SAI_CTRL_1	[7:0]	SAI_DRV	BCLK_POL	TDM_BCLKS		FSYNC_MODE	SDATA_FMT	SAI_MODE	PDM_MODE	0x00	R/W	
0x05	SAI_CTRL_2	[7:0]	RESERVED	PAD_DRV	AUTO_SAI	MC_I2S	AUTO_SLOT	TDM_SLOT			0x08	R/W	
0x06	SAI_PLACEMENT_1	[7:0]	RESERVED		P1_DAC		RESERVED	P1_SNS			0x01	R/W	
0x07	SAI_PLACEMENT_2	[7:0]	RESERVED		P2_DAC		RESERVED	P2_SNS			0x20	R/W	
0x08	SAI_PLACEMENT_3	[7:0]	RESERVED		P3_DAC		RESERVED	P3_SNS			0x32	R/W	
0x09	SAI_PLACEMENT_4	[7:0]	RESERVED		P4_DAC		RESERVED	P4_SNS			0x07	R/W	
0x0A	SAI_PLACEMENT_5	[7:0]	RESERVED					P5_SNS			0x07	R/W	
0x0B	SAI_PLACEMENT_6	[7:0]	RESERVED					P6_SNS			0x07	R/W	
0x0C	BATTERY_V_OUT	[7:0]	VBAT									0x00	R
0x0D	LIMITER_CTRL_1	[7:0]	SLOPE		VBAT_INF			VBAT_TRACK	LIM_EN		0xA4	R/W	
0x0E	LIMITER_CTRL_2	[7:0]	LIM_RRT		LIM_ATR		LIM_THRES			0x73	R/W		
0x0F	LIMITER_CTRL_3	[7:0]	RESERVED				TAV	VBAT_HYST			0x00	R/W	
0x10	STATUS_1	[7:0]	BST_FLT	RESERVED	LIM_EG	CLIP	UVLO	AMP_OC	OTF	BAT_WARN	0x00	R	
0x11	STATUS_2	[7:0]	RESERVED								OTW	0x00	R
0x12	FAULT_CTRL	[7:0]	OTW_GAIN		MAX_AR		MRCV	ARCV_UV	ARCV_OT	ARCV_OC	0x30	R/W	
0x13	PDM_CTRL	[7:0]	PDM_LR_SEL	PAT_CTRL_EN	RESERVED	I2C_ADDR_SET	LOW_LATENCY		SHARED_CLOCK	SEL_VBAT	0x40	R/W	
0x14	MCLK_RATIO	[7:0]	RESERVED			AMCS	MCS			0x11	R/W		
0x15	BOOST_CTRL_1	[7:0]	ADJ_PGATE		RESERVED			EN_DSCGB	FPWMB	SEL_FREQ	0x03	R/W	
0x16	BOOST_CTRL_2	[7:0]	RESERVED				ARCV_BST	RESERVED	SEL_GM		0x00	R/W	
0xFF	SOFT_RESET	[7:0]	SOFT_RESET									0x00	R

REGISTER DETAILS

POWER CONTROL REGISTER

Address: 0x00, Reset: 0x81, Name: POWER_CTRL

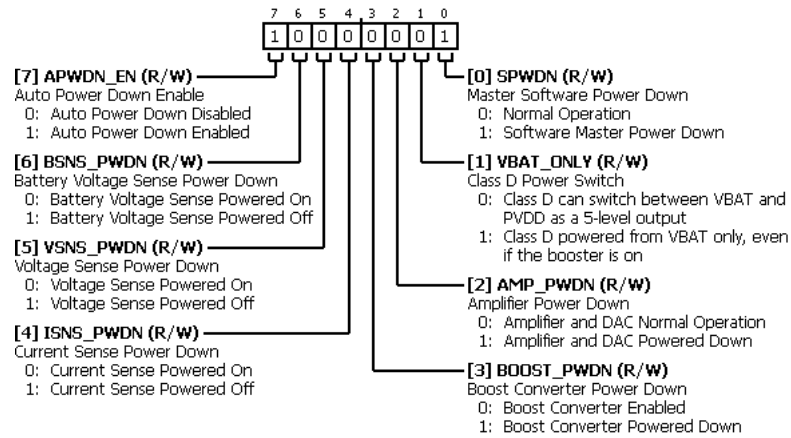

Table 26. Bit Descriptions for POWER_CTRL

Bits	Bit Name	Settings	Description	Reset	Access
7	APWDN_EN	0 1	Auto Power-Down Enable. Auto power down automatically puts the IC in a low power state when 2048 consecutive zero input samples have been received. Auto Power-Down Disabled. Auto Power-Down Enabled When APWDN_EN=1. The device automatically powers down when 2048 consecutive zero value input samples have been received. The device automatically powers up when a single non zero sample is received.	0x1	R/W
6	BSNS_PWDN	0 1	Battery Voltage Sense Power Down. Battery Voltage Sense Powered On. Battery Voltage Sense Powered Off.	0x0	R/W
5	VSNS_PWDN	0 1	Voltage Sense Power-Down. Voltage Sense Powered On. Voltage Sense Powered Off.	0x0	R/W
4	ISNS_PWDN	0 1	Current Sense Power Down. Current Sense Powered On. Current Sense Powered Off.	0x0	R/W
3	BOOST_PWDN	0 1	Boost Converter Power-Down. When the boost converter is powered down, the Class-D operates directly from VBAT power supply. Boost Converter Enabled. Boost Converter Powered Down.	0x0	R/W
2	AMP_PWDN	0 1	Amplifier Power-Down. Amplifier and DAC Normal Operation. Amplifier and DAC Powered Down.	0x0	R/W
1	VBAT_ONLY	0 1	Class-D Power Switch. Class-D can switch between VBAT and PVDD as a five-level output. Class-D powered from VBAT only, even if the booster is on.	0x0	R/W
0	SPWDN	0 1	Master Software Power-Down. Software power-down puts all blocks except the I ² C interface in a low power state. Normal Operation. Software Master Power-Down.	0x1	R/W

AMP AND SENSE CONTROL REGISTER

Address: 0x01, Reset: 0x09, Name: AMP_SNS_CTRL

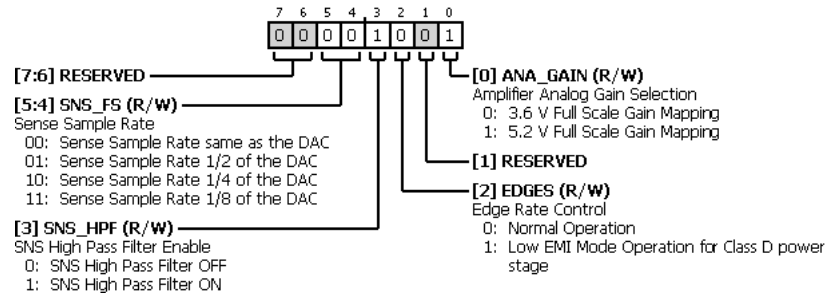

Table 27. Bit Descriptions for AMP_SNS_CTRL

Bits	Bit Name	Settings	Description	Reset	Access
[7:6]	RESERVED		Reserved.	0x0	R/W
[5:4]	SNS_FS	00 01 10 11	Sense Sample Rate. The sense output sample rate can be set at a lower rate than the DAC. Sense Sample Rate same as the DAC. Sense Sample Rate 1/2 of the DAC. Sense Sample Rate 1/4 of the DAC. Sense Sample Rate 1/8 of the DAC.	0x0	R/W
3	SNS_HPF	0 1	SNS High Pass Filter Enable. SNS High Pass Filter Off. SNS High Pass Filter On	0x1	R/W
2	EDGES	0 1	Edge Rate Control. This controls the edge speed of the power stage. The low EMI operation mode reduces the edge speed, lowering EMI and power efficiency. Normal Operation. Low EMI Mode Operation for Class-D power stage.	0x0	R/W
1	RESERVED		Reserved.	0x0	R/W
0	ANA_GAIN	0 1	Amplifier Analog Gain Selection. 3.6 V Full-Scale Gain Mapping. 5.2 V Full-Scale Gain Mapping.	0x1	R/W

DAC CONTROL REGISTER

Address: 0x02, Reset: 0x32, Name: DAC_CTRL

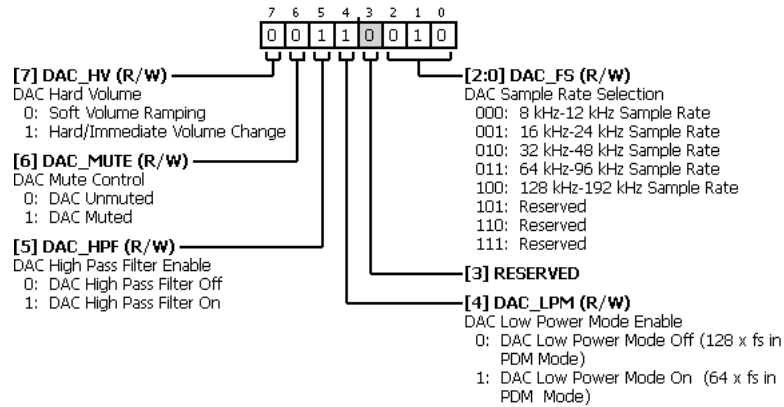

Table 28. Bit Descriptions for DAC_CTRL

Bits	Bit Name	Settings	Description	Reset	Access
7	DAC_HV	0 1	DAC Hard Volume Soft Volume Ramping Hard/Immediate Volume Change	0x0	R/W
6	DAC_MUTE	0 1	DAC Mute Control DAC Unmuted DAC Muted	0x0	R/W
5	DAC_HPF	0 1	DAC High-Pass Filter Enable DAC High-Pass Filter Off DAC High-Pass Filter On	0x1	R/W
4	DAC_LPM	0 1	DAC Low Power Mode Enable DAC Low Power Mode Off (128 × fs in PDM Mode) DAC Low Power Mode On (64 × fs in PDM Mode)	0x1	R/W
3	RESERVED		Reserved.	0x0	R/W
[2:0]	DAC_FS	000 001 010 011 100 101 110 111	DAC Sample Rate Selection 8 kHz to 12 kHz Sample Rate 16 kHz to 24 kHz Sample Rate 32 kHz to 48 kHz Sample Rate 64 kHz to 96 kHz Sample Rate 128 kHz to 192 kHz Sample Rate Reserved Reserved Reserved	0x2	R/W

DAC VOLUME CONTROL REGISTER

Address: 0x03, Reset: 0x40, Name: DAC_VOLUME

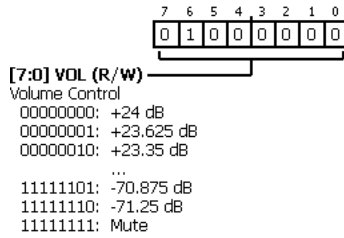
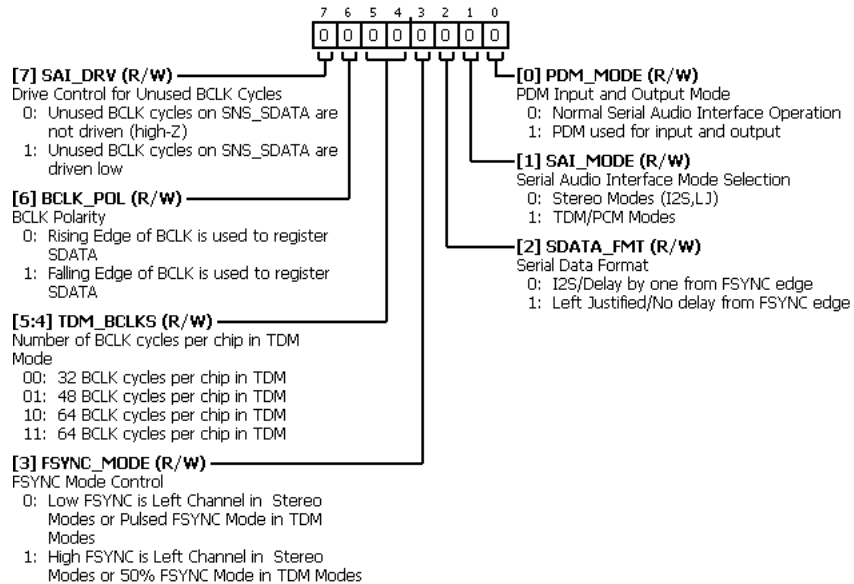

Table 29. Bit Descriptions for DAC_VOLUME

Bits	Bit Name	Settings	Description	Reset	Access
[7:0]	VOL		Volume Control	0x40	R/W
		00000000	+24 dB		
		00000001	+23.625 dB		
		00000010	+23.35 dB		
		00000011	+22.875 dB		
		00000100	+22.5 dB		
		00000101	...		
		00111111	+0.375 dB		
		01000000	0		
		01000001	-0.375 dB		
		01000010	...		
		11111101	-70.875 dB		
		11111110	-71.25 dB		
		11111111	Mute		

SERIAL AUDIO INTERFACE CONTROL 1 REGISTER

Address: 0x04, Reset: 0x00, Name: SAI_CTRL_1

**Table 30. Bit Descriptions for SAI_CTRL_1**

Bits	Bit Name	Settings	Description	Reset	Access
7	SAI_DRV	0 1	Drive Control for Unused BCLK Cycles Unused BCLK cycles on SNS_SDATA are not driven (high-Z) Unused BCLK cycles on SNS_SDATA are driven low	0x0	R/W
6	BCLK_POL	0 1	BCLK Polarity Rising Edge of BCLK is used to register SDATA Falling Edge of BCLK is used to register SDATA	0x0	R/W
[5:4]	TDM_BCLKS	00 01 10 11	Number of BCLK cycles per chip in TDM Mode. Any number of BCLK cycles per FSYNC can be used in stereo modes (I ² S/left justified) or in TDM mode with only one chip. When in TDM mode, with multiple chips on the TDM bus, the number of BCLK cycles per chip must be defined. 32 BCLK cycles per chip in TDM 48 BCLK cycles per chip in TDM 64 BCLK cycles per chip in TDM 64 BCLK cycles per chip in TDM	0x0	R/W
3	FSYNC_MODE	0 1	FSYNC Mode Control Low FSYNC is Left Channel in Stereo Modes or Pulsed FSYNC Mode in TDM Modes High FSYNC is Left Channel in Stereo Modes or 50% FSYNC Mode in TDM Modes	0x0	R/W
2	SDATA_FMT	0 1	Serial Data Format I ² S/Delay by one from FSYNC edge Left Justified/No delay from FSYNC edge	0x0	R/W
1	SAI_MODE	0 1	Serial Audio Interface Mode Selection Stereo Modes (I ² S, left justified) TDM/PCM Modes	0x0	R/W
0	PDM_MODE	0 1	PDM Input and Output Mode Normal Serial Audio Interface Operation PDM used for input and output	0x0	R/W

SERIAL AUDIO INTERFACE CONTROL 2 REGISTER

Address: 0x05, Reset: 0x08, Name: SAI_CTRL_2

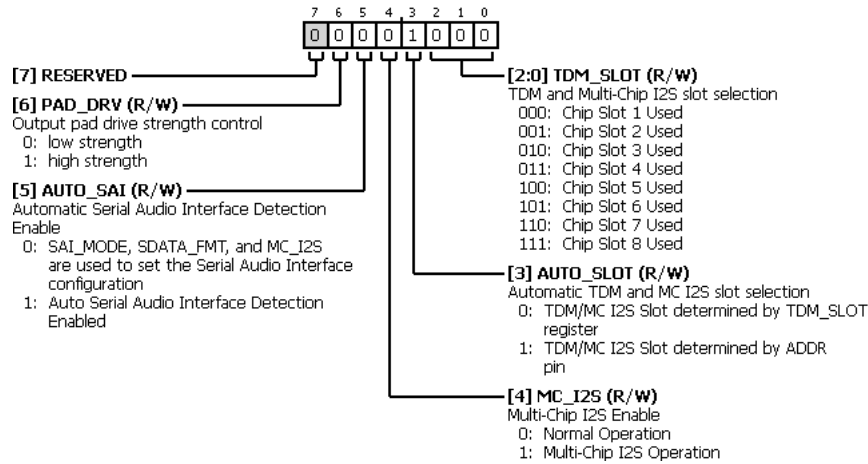

Table 31. Bit Descriptions for SAI_CTRL_2

Bits	Bit Name	Settings	Description	Reset	Access
7	RESERVED		Reserved.	0x0	R/W
6	PAD_DRV	0 1	Output pad drive strength control. SNS_PDM_DAT/SNS_SDATAO pin output drive strength. 0 low strength 1 high strength	0x0	R/W
5	AUTO_SAI	0 1	Automatic Serial Audio Interface Detection Enable. When AUTO_SAI = 1 the Serial Audio Interface automatically configures based on the connections of BCLK and FSYNC. When FSYNC and BCLK are connected normally, and a pulsed FSYNC is detected, the interface automatically configures for TDM operation. When FSYNC and BCLK are connected normally, and a 50% duty cycle FSYNC is detected, the interface automatically configures for multichip I ² S operation. When FSYNC and BCLK are connected to the opposite pins, the interface automatically configures for normal I ² S operation. When set for automatic detection the values of SAI_MODE and SDATA_FMT are ignored. 0 SAI_MODE, SDATA_FMT, and MC_I2S are used to set the Serial Audio Interface configuration 1 Auto Serial Audio Interface Detection Enabled	0x0	R/W
4	MC_I2S	0 1	Multichip I ² S Enable. When MC_I2S is selected, this overrides the SAI_MODE selection. 0 Normal Operation 1 Multichip I ² S Operation	0x0	R/W
3	AUTO_SLOT	0 1	Automatic TDM and MC I ² S slot selection 0 TDM/MC I ² S Slot determined by TDM_SLOT bits 1 TDM/MC I ² S Slot determined by ADDR pin	0x1	R/W
[2:0]	TDM_SLOT	000 001 010 011 100 101 110 111	TDM and Multichip I ² S slot selection Chip Slot 1 Used Chip Slot 2 Used Chip Slot 3 Used Chip Slot 4 Used Chip Slot 5 Used Chip Slot 6 Used Chip Slot 7 Used Chip Slot 8 Used	0x0	R/W

SERIAL AUDIO INTERFACE PLACEMENT 1 CONTROL REGISTER

Address: 0x06, Reset: 0x01, Name: SAI_PLACEMENT_1

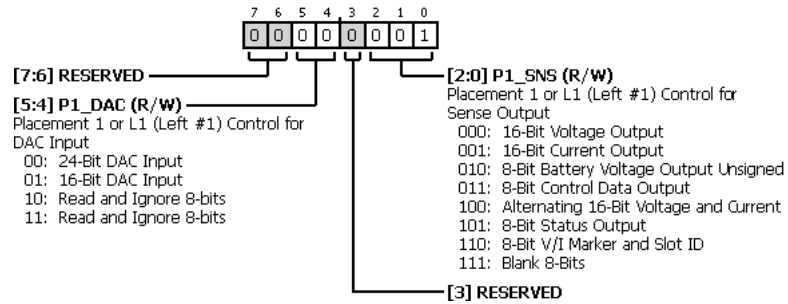

Table 32. Bit Descriptions for SAI_PLACEMENT_1

Bits	Bit Name	Settings	Description	Reset	Access
[7:6]	RESERVED		Reserved.	0x0	R/W
[5:4]	P1_DAC	00 01 10 11	Placement 1 or L1 (Left 1) Control for DAC Input. Selects the size of the data to be read. 24 bits or 16 bits. This slot can also be set to read in eight bits, throw them away, and move on to Placement P2 to read the audio data. 24-Bit DAC Input 16-Bit DAC Input Read and Ignore 8-bits Read and Ignore 8-bits	0x0	R/W
3	RESERVED		Reserved.	0x0	R/W
[2:0]	P1_SNS	000 001 010 011 100 101 110 111	Placement 1 or L1 (Left 1) Control for Sense Output. 16-Bit Voltage Output 16-Bit Current Output 8-Bit Battery Voltage Output Unsigned 8-Bit Control Data Output Alternating 16-Bit Voltage and Current 8-Bit Status Output 8-Bit V/I Marker and Slot ID Blank 8 Bits	0x1	R/W

SERIAL AUDIO INTERFACE PLACEMENT 2 CONTROL REGISTER

Address: 0x07, Reset: 0x20, Name: SAI_PLACEMENT_2

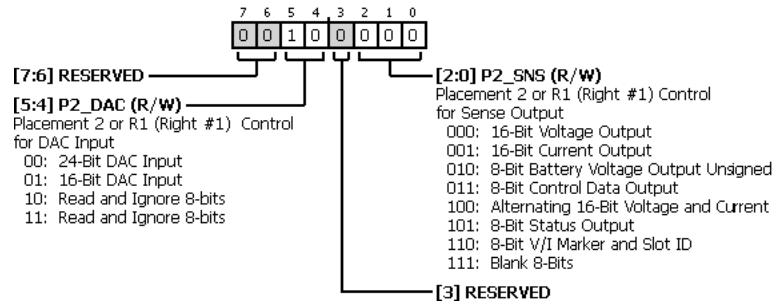

Table 33. Bit Descriptions for SAI_PLACEMENT_2

Bits	Bit Name	Settings	Description	Reset	Access
[7:6]	RESERVED		Reserved.	0x0	R/W
[5:4]	P2_DAC	00 01 10 11	Placement 2 or R1 (Right 1) Control for DAC Input. Selects the size of the data to be read. 24 bits or 16 bits. This slot can also be set to read in eight bits, throw them away, and move on to Placement P3 to read the audio data. 24-Bit DAC Input 16-Bit DAC Input Read and Ignore 8 bits Read and Ignore 8 bits	0x2	R/W
3	RESERVED		Reserved.	0x0	R/W
[2:0]	P2_SNS	000 001 010 011 100 101 110 111	Placement 2 or R1 (Right 1) Control for Sense Output. 16-Bit Voltage Output 16-Bit Current Output 8-Bit Battery Voltage Output Unsigned 8-Bit Control Data Output Alternating 16-Bit Voltage and Current 8-Bit Status Output 8-Bit V/I Marker and Slot ID Blank 8 Bits	0x0	R/W

SERIAL AUDIO INTERFACE PLACEMENT 3 CONTROL REGISTER

Address: 0x08, Reset: 0x32, Name: SAI_PLACEMENT_3

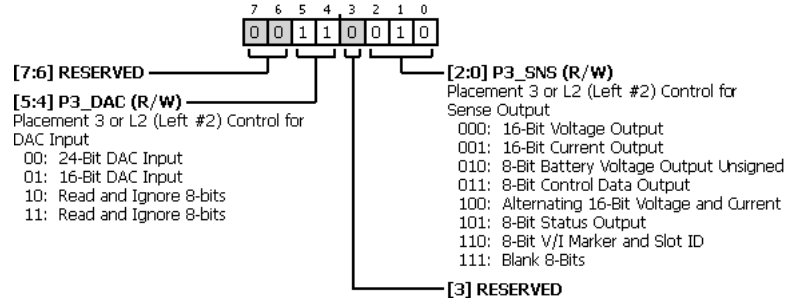

Table 34. Bit Descriptions for SAI_PLACEMENT_3

Bits	Bit Name	Settings	Description	Reset	Access
[7:6]	RESERVED		Reserved.	0x0	R/W
[5:4]	P3_DAC	00 01 10 11	Placement 3 or L2 (Left 2) Control for DAC Input. Selects the size of the data to be read. 24 bits or 16 bits. This slot can also be set to read in eight bits, throw them away, and move on to placement P4 to read the audio data. 24-Bit DAC Input 16-Bit DAC Input Read and Ignore 8 bits Read and Ignore 8 bits	0x3	R/W
3	RESERVED		Reserved.	0x0	R/W
[2:0]	P3_SNS	000 001 010 011 100 101 110 111	Placement 3 or L2 (Left 2) Control for Sense Output. 16-Bit Voltage Output 16-Bit Current Output 8-Bit Battery Voltage Output Unsigned 8-Bit Control Data Output Alternating 16-Bit Voltage and Current 8-Bit Status Output 8-Bit V/I Marker and Slot ID Blank 8 Bits	0x2	R/W

SERIAL AUDIO INTERFACE PLACEMENT 4 CONTROL REGISTER

Address: 0x09, Reset: 0x07, Name: SAI_PLACEMENT_4

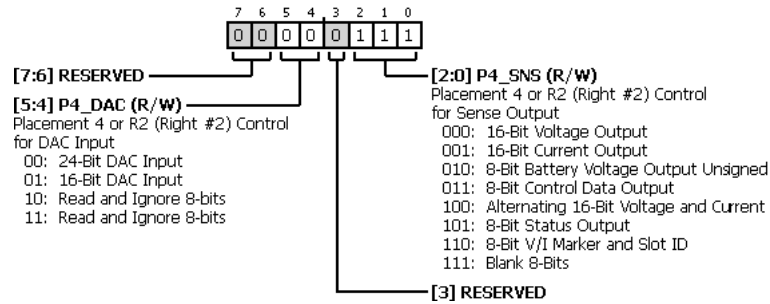

Table 35. Bit Descriptions for SAI_PLACEMENT_4

Bits	Bit Name	Settings	Description	Reset	Access
[7:6]	RESERVED		Reserved.	0x0	R/W
[5:4]	P4_DAC	00 01 10 11	Placement 4 or R2 (Right 2) Control for DAC Input 24-Bit DAC Input 16-Bit DAC Input Read and Ignore 8 bits Read and Ignore 8 bits	0x0	R/W
3	RESERVED		Reserved.	0x0	R/W
[2:0]	P4_SNS	000 001 010 011 100 101 110 111	Placement 4 or R2 (Right 2) Control for Sense Output 16-Bit Voltage Output 16-Bit Current Output 8-Bit Battery Voltage Output Unsigned 8-Bit Control Data Output Alternating 16-Bit Voltage and Current 8-Bit Status Output 8-Bit V/I Marker and Slot ID Blank 8 Bits	0x7	R/W

SERIAL AUDIO INTERFACE PLACEMENT 5 CONTROL REGISTER

Address: 0x0A, Reset: 0x07, Name: SAI_PLACEMENT_5

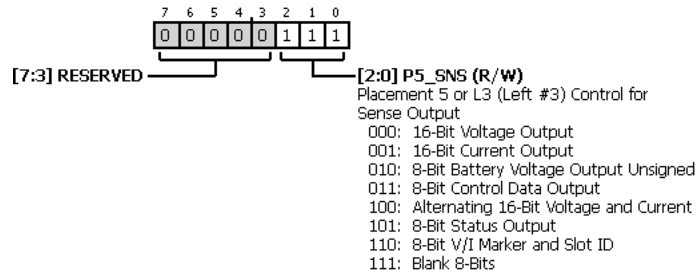

Table 36. Bit Descriptions for SAI_PLACEMENT_5

Bits	Bit Name	Settings	Description	Reset	Access
[7:3]	RESERVED		Reserved.	0x0	R/W
[2:0]	P5_SNS	000 001 010 011 100 101 110 111	Placement 5 or L3 (Left 3) Control for Sense Output 16-Bit Voltage Output 16-Bit Current Output 8-Bit Battery Voltage Output Unsigned 8-Bit Control Data Output Alternating 16-Bit Voltage and Current 8-Bit Status Output 8-Bit V/I Marker and Slot ID Blank 8 Bits	0x7	R/W

SERIAL AUDIO INTERFACE PLACEMENT 6 CONTROL REGISTER

Address: 0x0B, Reset: 0x07, Name: SAI_PLACEMENT_6

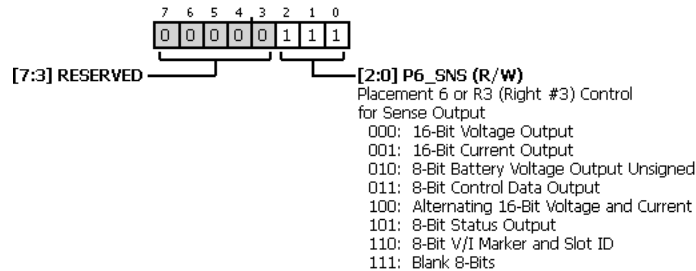

Table 37. Bit Descriptions for SAI_PLACEMENT_6

Bits	Bit Name	Settings	Description	Reset	Access
[7:3]	RESERVED		Reserved.	0x0	R/W
[2:0]	P6_SNS	000 001 010 011 100 101 110 111	Placement 6 or R3 (Right 3) Control for Sense Output 16-Bit Voltage Output 16-Bit Current Output 8-Bit Battery Voltage Output Unsigned 8-Bit Control Data Output Alternating 16-Bit Voltage and Current 8-Bit Status Output 8-Bit V/I Marker and Slot ID Blank 8 Bits	0x7	R/W

BATTERY VOLTAGE OUTPUT REGISTER

Address: 0x0C, Reset: 0x00, Name: BATTERY_V_OUT

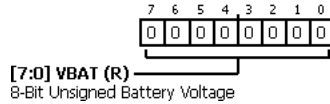

Table 38. Bit Descriptions for BATTERY_V_OUT

Bits	Bit Name	Settings	Description	Reset	Access
[7:0]	VBAT		8-Bit Unsigned Battery Voltage	0x0	R

LIMITER CONTROL 1 REGISTER

Address: 0x0D, Reset: 0xA4, Name: LIMITER_CTRL_1

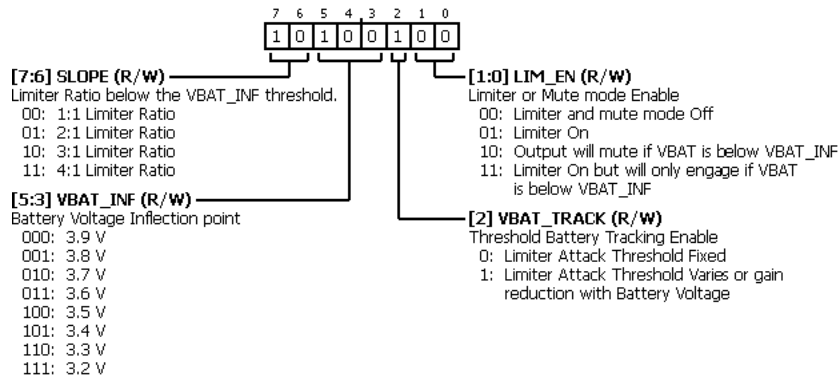

Table 39. Bit Descriptions for LIMITER_CTRL_1

Bits	Bit Name	Settings	Description	Reset	Access
[7:6]	SLOPE		Limiter Ratio below the VBAT_INF threshold. Limiter ratio once the VBAT voltage falls below the VBAT_INF threshold. This sets the slope of the limiter curve as the VBAT voltage falls. 00 1:1 Limiter Ratio 01 2:1 Limiter Ratio 10 3:1 Limiter Ratio 11 4:1 Limiter Ratio	0x2	R/W
[5:3]	VBAT_INF		Battery Voltage Inflection point. When VBAT drops below the inflection point and VBAT_TRACK = 1 the limiter threshold starts being lowered to limit maximum output and peak current from the battery. The amount of reduction when the battery voltage is lower than VBAT_INF is determined by the SLOPE bits. 000 3.9 V 001 3.8 V 010 3.7 V 011 3.6 V 100 3.5 V 101 3.4 V 110 3.3 V 111 3.2 V	0x4	R/W
2	VBAT_TRACK		Threshold Battery Tracking Enable 0 Limiter Attack Threshold Fixed 1 Limiter Attack Threshold Varies or gain reduction with Battery Voltage	0x1	R/W
[1:0]	LIM_EN		Limiter or Mute mode Enable 00 Limiter and mute mode Off 01 Limiter On 10 Output will mute if VBAT is below VBAT_INF 11 Limiter On but will only engage if VBAT is below VBAT_INF	0x0	R/W

LIMITER CONTROL 2 REGISTER

Address: 0x0E, Reset: 0x73, Name: LIMITER_CTRL_2

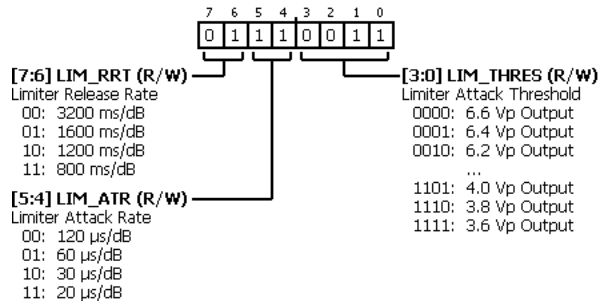

Table 40. Bit Descriptions for LIMITER_CTRL_2

Bits	Bit Name	Settings	Description	Reset	Access
[7:6]	LIM_RRT	00 01 10 11	Limiter Release Rate 3200 ms/dB 1600 ms/dB 1200 ms/dB 800 ms/dB	0x1	R/W
[5:4]	LIM_ATR	00 01 10 11	Limiter Attack Rate 120 μ s/dB 60 μ s/dB 30 μ s/dB 20 μ s/dB	0x3	R/W
[3:0]	LIM_THRES	0000 0001 0010 0011 0100 0101 0110 0111 1000 1001 1010 1011 1100 1101 1110 1111	Limiter Attack Threshold 6.6 V peak Output 6.4 V peak Output 6.2 V peak Output 6.0 V peak Output 5.8 V peak Output 5.6 V peak Output 5.4 V peak Output 5.2 V peak Output 5.0 V peak Output 4.8 V peak Output 4.6 V peak Output 4.4 V peak Output 4.2 V peak Output 4.0 V peak Output 3.8 V peak Output 3.6 V peak Output	0x3	R/W

LIMITER CONTROL 3 REGISTER

Address: 0x0F, Reset: 0x00, Name: LIMITER_CTRL_3

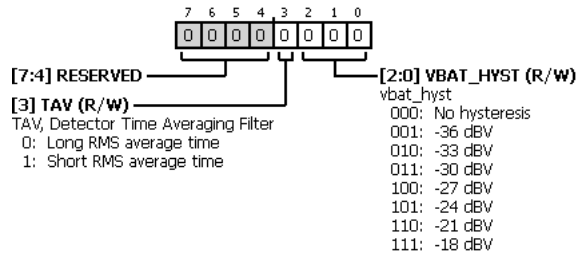

Table 41. Bit Descriptions for LIMITER_CTRL_3

Bits	Bit Name	Settings	Description	Reset	Access
[7:4]	RESERVED		Reserved.	0x0	R/W
3	TAV	0 1	TAV, Detector Time Averaging Filter 0: Long RMS average time 1: Short RMS average time	0x0	R/W
[2:0]	VBAT_HYST	000 001 010 011 100 101 110 111	vbat_hyst No hysteresis -36 dBV -33 dBV -30 dBV -27 dBV -24 dBV -21 dBV -18 dBV	0x0	R/W

STATUS 1 REGISTER

Address: 0x10, Reset: 0x00, Name: STATUS_1

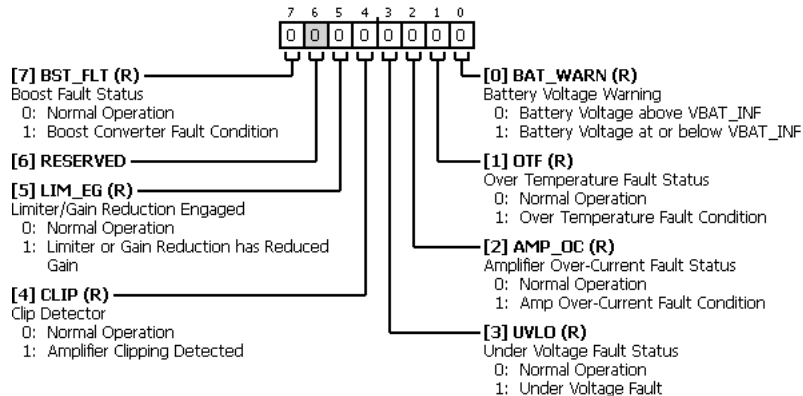

Table 42. Bit Descriptions for STATUS_1

Bits	Bit Name	Settings	Description	Reset	Access
7	BST_FLT	0 1	Boost Fault Status Normal Operation Boost Converter Fault Condition	0x0	R
6	RESERVED		Reserved.	0x0	R
5	LIM_EG	0 1	Limiter/Gain Reduction Engaged Normal Operation Limiter or Gain Reduction has Reduced Gain	0x0	R
4	CLIP	0 1	Clip Detector Normal Operation Amplifier Clipping Detected	0x0	R
3	UVLO	0 1	Under Voltage Fault Status Normal Operation Under Voltage Fault	0x0	R
2	AMP_OC	0 1	Amplifier Overcurrent Fault Status Normal Operation Amp Overcurrent Fault Condition	0x0	R
1	OTF	0 1	Over Temperature Fault Status Normal Operation Over Temperature Fault Condition	0x0	R
0	BAT_WARN	0 1	Battery Voltage Warning Battery Voltage above VBAT_INF Battery Voltage at or below VBAT_INF	0x0	R

STATUS 2 REGISTER

Address: 0x11, Reset: 0x00, Name: STATUS_2

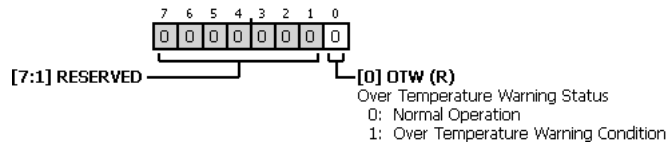

Table 43. Bit Descriptions for STATUS_2

Bits	Bit Name	Settings	Description	Reset	Access
[7:1]	RESERVED		Reserved.	0x0	R
0	OTW	0 1	Overtemperature Warning Status Normal Operation Overtemperature Warning Condition	0x0	R

FAULT CONTROL REGISTER

Address: 0x12, Reset: 0x30, Name: FAULT_CTRL

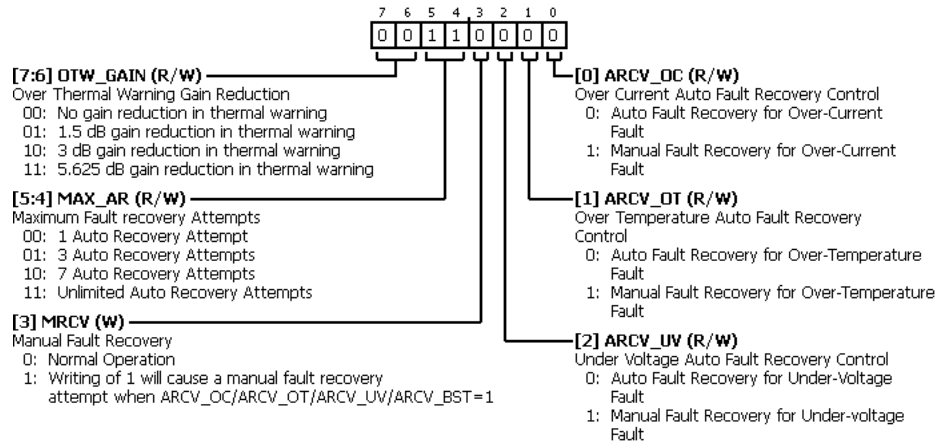

Table 44. Bit Descriptions for FAULT_CTRL

Bits	Bit Name	Settings	Description	Reset	Access
[7:6]	OTW_GAIN	00 01 10 11	Over Thermal Warning Gain Reduction No gain reduction in thermal warning 1.5 dB gain reduction in thermal warning 3 dB gain reduction in thermal warning 5.625 dB gain reduction in thermal warning	0x0	R/W
[5:4]	MAX_AR	00 01 10 11	Maximum Fault recovery Attempts. The Maximum autorecovery register determines how many attempts at auto recovery are performed. 1 Autorecovery Attempt 3 Autorecovery Attempts 7 Autorecovery Attempts Unlimited Autorecovery Attempts	0x3	R/W
3	MRCV	0 1	Manual Fault Recovery Normal Operation Writing of 1 causes a manual fault recovery attempt when ARCV_OC/ARCV_OT/ARCV_UV/ARCV_BST = 1	0x0	W
2	ARCV_UV	0 1	Undervoltage Autofault Recovery Control Auto Fault Recovery for Undervoltage Fault Manual Fault Recovery for Undervoltage Fault	0x0	R/W
1	ARCV_OT	0 1	Overtemperature Auto Fault Recovery Control Auto Fault Recovery for Overtemperature Fault Manual Fault Recovery for Overtemperature Fault	0x0	R/W
0	ARCV_OC	0 1	Overcurrent Auto Fault Recovery Control Auto Fault Recovery for Overcurrent Fault Manual Fault Recovery for Overcurrent Fault	0x0	R/W

PDM CONTROL REGISTER

Address: 0x13, Reset: 0x40, Name: PDM_CTRL

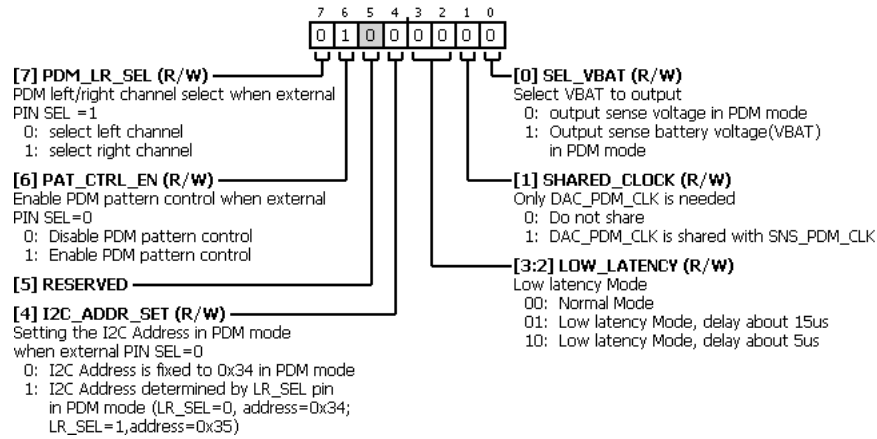

Table 45. Bit Descriptions for PDM_CTRL

Bits	Bit Name	Settings	Description	Reset	Access
7	PDM_LR_SEL	0 1	PDM left/right channel select when external PIN SEL =1 select left channel select right channel	0x0	R/W
6	PAT_CTRL_EN	0 1	Enable PDM pattern control when external PIN SEL=0 Disable PDM pattern control Enable PDM pattern control	0x1	R/W
5	RESERVED		Reserved.	0x0	R/W
4	I2C_ADDR_SET	0 1	Setting the I2C Address in PDM mode when external PIN SEL = 0 I ² C Address is fixed to 0x34 in PDM mode I ² C Address determined by LR_SEL/ADDR pin in PDM mode (LR_SEL/ADDR = 0, Address = 0x34; LR_SEL/ADDR = 1, Address = 0x35)	0x0	R/W
[3:2]	LOW_LATENCY	00 01 10	Low latency Mode Normal Mode Low latency Mode, delay about 15 μs Low latency Mode, delay about 5 μs	0x0	R/W
1	SHARED_CLOCK	0 1	Only DAC_PDM_CLK is needed Do not share DAC_PDM_CLK is shared with SNS_PDM_CLK	0x0	R/W
0	SEL_VBAT	0 1	Select VBAT to output output sense voltage in PDM mode Output sense battery voltage (VBAT) in PDM mode	0x0	R/W

MCLK RATIO SETTING REGISTER

Address: 0x14, Reset: 0x11, Name: MCLK_RATIO

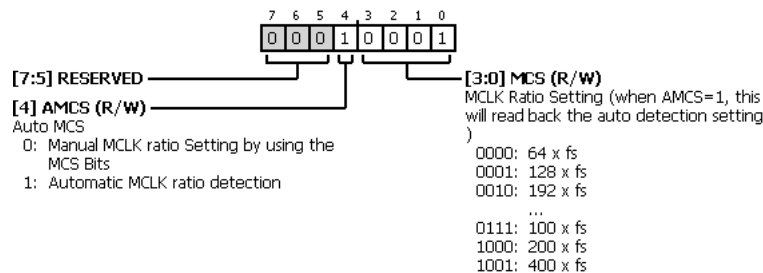

Table 46. Bit Descriptions for MCLK_RATIO

Bits	Bit Name	Settings	Description	Reset	Access
[7:5]	RESERVED		Reserved.	0x0	R/W
4	AMCS	0 1	Auto MCS. Automatic or manual Master Clock ratio Setting Manual MCLK ratio Setting by using the MCS Bits Automatic MCLK ratio detection The Master Clock ratio Setting that is detected is stored in the MCS register bits to allow the setting to be read.	0x1	R/W
[3:0]	MCS	0000 0001 0010 0011 0100 0101 0110 0111 1000 1001	MCLK Ratio Setting (when AMCS = 1, this reads back the auto detection setting) 64 × fs 128 × fs 192 × fs 256 × fs 384 × fs 512 × fs 50 × fs 100 × fs 200 × fs 400 × fs	0x1	R/W

BOOST CONTROL 1 REGISTER

Address: 0x15, Reset: 0x03, Name: BOOST_CTRL_1

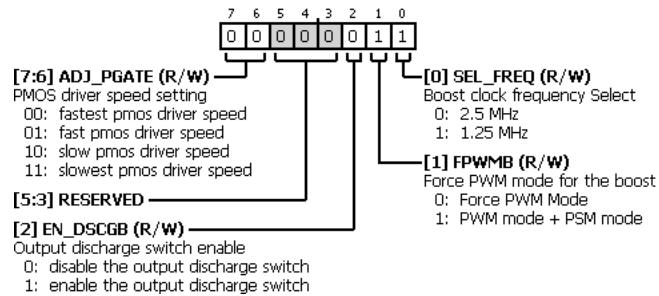

Table 47. Bit Descriptions for BOOST_CTRL_1

Bits	Bit Name	Settings	Description	Reset	Access
[7:6]	ADJ_PGATE	00 01 10 11	PMOS driver speed setting Fastest pmos driver speed Fast pmos driver speed Slow pmos driver speed Slowest pmos driver speed	0x0	R/W
[5:3]	RESERVED		Reserved.	0x0	R/W
2	EN_DSCGB	0 1	Output discharge switch enable Disable the output discharge switch Enable the output discharge switch	0x0	R/W
1	FPWMB	0 1	Force PWM mode for the boost Force PWM Mode PWM mode + PSM mode	0x1	R/W
0	SEL_FREQ	0 1	Boost clock frequency Select 2.5 MHz 1.25 MHz	0x1	R/W

BOOST CONTROL 2 REGISTER

Address: 0x16, Reset: 0x00, Name: BOOST_CTRL_2

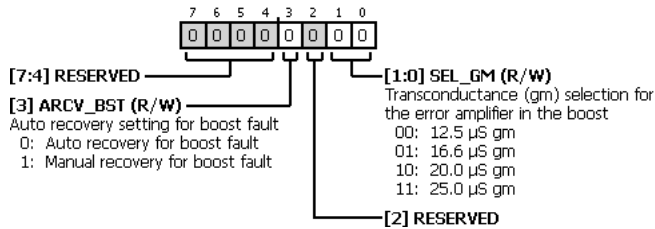

Table 48. Bit Descriptions for BOOST_CTRL_2

Bits	Bit Name	Settings	Description	Reset	Access
[7:4]	RESERVED		Reserved	0x0	R/W
3	ARCV_BST	0 1	Autorecovery setting for boost fault Autorecovery for boost fault Manual recovery for boost fault	0x0	R/W
2	RESERVED		Reserved	0x0	R/W
[1:0]	SEL_GM	00 01 10 11	Transconductance (g_m) selection for the error amplifier in the boost 12.5 $\mu S g_m$ 16.6 $\mu S g_m$ 20.0 $\mu S g_m$ 25.0 $\mu S g_m$	0x0	R/W

SOFT RESET REGISTER

Address: 0xFF, Reset: 0x00, Name: SOFT_RESET

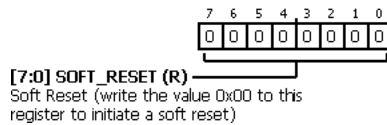

Table 49. Bit Descriptions for SOFT_RESET

Bits	Bit Name	Settings	Description	Reset	Access
[7:0]	SOFT_RESET		Soft Reset (write the value 0x00 to this register to initiate a soft reset)	0x0	R

OUTLINE DIMENSIONS

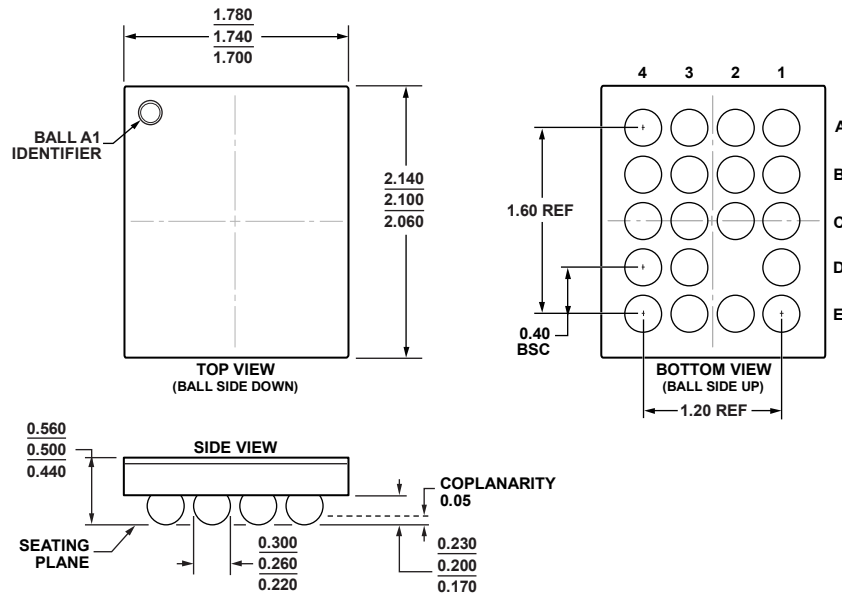

Figure 58. 19-Ball Wafer Level Chip Scale Package [WLCSP]
(CB-19-1)

Dimensions shown in millimeters

12-19-2012/A

ORDERING GUIDE

Model ¹	Temperature Range	Package Description	Package Option
SSM4567ACBZ-R7	-40°C to +85°C	19-Ball WLCSP	CB-19-1
SSM4567ACBZ-RL	-40°C to +85°C	19-Ball WLCSP	CB-19-1
EVAL-SSM4567Z		Evaluation Board	
EVAL-SSM4567MINIZ		Evaluation Board	

¹Z = RoHS Compliant Part.

¹C refers to a communications protocol originally developed by Philips Semiconductors (now NXP Semiconductors).