

FEATURES

- 117 dB dynamic range
- 0.006% typical THD+N (@ 1 kHz, unity gain)
- 140 dB gain range
- No external trimming required
- Differential inputs
- Complementary gain outputs
- Buffered control port
- I-V converter on-chip
- Low external parts count
- Low cost

GENERAL DESCRIPTION

The **SSM2018** represents the continuing evolution of the Frey Operational Voltage Controlled Element (OVCE) topology that permits flexibility in the design of high performance volume control systems. The **SSM2018** is laser trimmed for gain core symmetry and offset. As a result, the **SSM2018** is the first professional audio quality VCA to offer trimless operation.

Due to careful gain core layout, the **SSM2018** combines the low noise of Class AB topologies with the low distortion of Class A circuits to offer an unprecedented level of sonic transparency.

FUNCTIONAL BLOCK DIAGRAM

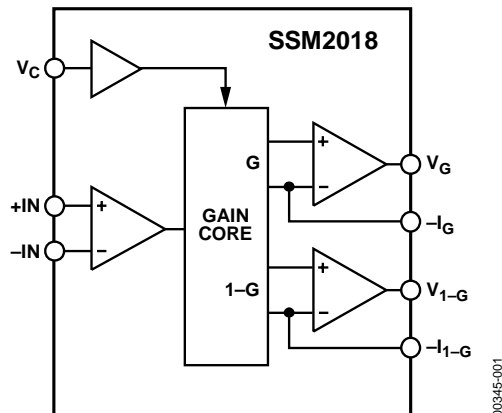

Figure 1.

00345-001

Additional features include differential inputs, a 140 dB (–100 dB to +40 dB) gain range, and a high impedance control port. The **SSM2018** provides an internal current-to-voltage converter. Thus, no external active components are required.

This device is offered in 16-lead, plastic DIP package and guaranteed for operation over the extended industrial temperature range of –40°C to +85°C.

TABLE OF CONTENTS

Features	1	Control Section.....	11
Functional Block Diagram	1	Applications Information	12
General Description	1	Basic VCA Configuration	12
Revision History	2	Proper Operating Mode for the SSM2018	12
Specifications.....	3	Output Drive.....	13
Electrical Specifications.....	3	Upgrading SSM2018 Sockets.....	13
Absolute Maximum Ratings.....	4	Temperature Compensation of the Gain Constant	13
Transistor Count.....	4	Digital Control of the Gain	14
Thermal Resistance	4	Supply Considerations and Single-Supply Operation.....	14
ESD Caution.....	4	Operational Voltage Controlled Element.....	14
Pin Configuration and Function Descriptions.....	5	Voltage Controlled Panner.....	15
Typical Performance Characteristics	6	Outline Dimensions	16
Theory of Operation	10	Ordering Guide	16
Compensating the SSM2018.....	10		

REVISION HISTORY

2/13—Rev. B to Rev. C

Updated Format.....	Universal
Reorganized Layout.....	Universal
Changed SSM2018T to SSM2018.....	Throughout
Changes to Table 2 and Transistor Count Section	4
Added Table 4.....	5
Changed Theory of Operation of the SSM2018T Section to Theory of Operation Section; Changes to Figure 28	10
Changes to Control Section	11
Changed Applications Section to Applications Information Section, Changes to Basic VCA Configuration Section	12
Changes to Output Drive Section, Upgrading SSM2018 Sockets Section, Temperature Compensation of the Gain Constant Section, Figure 30, and Figure 31	13
Changes to Digital Control of the Gain Section.....	14
Updated Outline Dimensions	16
Changes to Ordering Guide	16

7/02—Rev. A to Rev. B

Deleted references to SSM2118T.....	Global
Edits to Features	1
Edits to General Description	1
Deleted SSM2118T Functional Block Diagram	1
Deleted 16-Lewad Plastic DIP and SOL from Pin Configurations.....	3
Edits to Ordering Guide	3
Deleted SSM2118T Typical Application Circuit	3
Deleted TPCs	7–8
Edits to Applications	10
Deleted section Basic VCA Configuration For The SSM21218T	11

SPECIFICATIONS

ELECTRICAL SPECIFICATIONS

$V_S = \pm 15\text{ V}$, $A_V = 0\text{ dB}$, $R_L = 100\text{ k}\Omega$, $f = 1\text{ kHz}$, $0\text{ dBu} = 0.775\text{ V rms}$, simple VCA application circuit with $18\text{ k}\Omega$ resistors, $-V_{IN}$ floating, and Class AB gain core bias ($R_B = 150\text{ k}\Omega$), $-40^\circ\text{C} < T_A < +85^\circ\text{C}$, unless otherwise noted. Typical specifications apply at $T_A = 25^\circ\text{C}$.

Table 1.

Parameter	Conditions	Min	Typ	Max	Max (E Grade)	Unit
AUDIO PERFORMANCE						
Noise	$V_{IN} = \text{GND}$, 20 kHz Bandwidth		-95	-93		dBu
Headroom	Clip Point = 1% THD + N		22			dBu
Total Harmonic Distortion plus Noise	2nd and 3rd Harmonics Only (25°C to 85°C) $A_V = 0\text{ dB}$, $V_{IN} = +10\text{ dBu}$ $A_V = +20\text{ dB}$, $V_{IN} = -10\text{ dBu}$ $A_V = -20\text{ dB}$, $V_{IN} = +10\text{ dBu}$		0.006	0.020	0.01	%
			0.013	0.03	0.02	%
			0.013	0.03	0.02	%
INPUT AMPLIFIER						
Bias Current	$V_{CM} = 0\text{ V}$		0.25	1		μA
Offset Voltage	$V_{CM} = 0\text{ V}$		1	15		mV
Offset Current	$V_{CM} = 0\text{ V}$		10	100		nA
Input Impedance			4			$\text{M}\Omega$
Common-Mode Range			± 13			V
Gain Bandwidth	VCA Configuration		0.7			MHz
	VCP Configuration		14			MHz
Slew Rate			5			$\text{V}/\mu\text{s}$
OUTPUT AMPLIFIER						
Offset Voltage	$V_{IN} = 0\text{ V}$, $V_C = 4\text{ V}$		1.0	15		mV
Output Voltage Swing	$I_{OUT} = 1.5\text{ mA}$ Positive Negative	10 -10	13 -14			V V
Minimum Load Resistance	For Full Output Swing		9			$\text{k}\Omega$
CONTROL PORT						
Bias Current			0.36	1		μA
Input Impedance			1			$\text{M}\Omega$
Gain Constant	Device Powered in Socket > 60 sec		-30			mV/dB
Gain Constant Temperature Coefficient			-3500			ppm/ $^\circ\text{C}$
Control Feedthrough	0 dB to -40 dB Gain Range		± 1	± 4	± 3	mV
Maximum Gain	$V_C = -1.3\text{ V}$		40			mV
Maximum Attenuation	$V_C = 4\text{ V}$		100			dB
POWER SUPPLIES						
Supply Voltage Range		± 5		± 18		V
Supply Current			11	15		mA
Power Supply Rejection Ratio			80			dB

ABSOLUTE MAXIMUM RATINGS

Table 2.

Parameter	Rating
Supply Voltage	
Dual Supply	$\pm 18\text{ V}$
Input Voltage	$\pm V_s$
Operating Temperature Range	-40°C to $+85^\circ\text{C}$
Storage Temperature	-65°C to $+150^\circ\text{C}$
Junction Temperature (T_j)	150°C
Lead Temperature (Soldering, 60 sec)	300°C
ESD Ratings	
883 (Human Body) Model	500 V
EIAJ Model	100 V

Stresses above those listed under Absolute Maximum Ratings may cause permanent damage to the device. This is a stress rating only; functional operation of the device at these or any other conditions above those indicated in the operational section of this specification is not implied. Exposure to absolute maximum rating conditions for extended periods may affect device reliability.

TRANSISTOR COUNT

Number of Transistors

SSM2018 125

THERMAL RESISTANCE

θ_{JA} is specified for worst-case conditions, that is, θ_{JA} is specified for device in socket for P-DIP.

Table 3. Thermal Resistance

Package Type	θ_{JA}	θ_{JC}	Unit
16-Lead, Plastic DIP	76	33	$^\circ\text{C/W}$

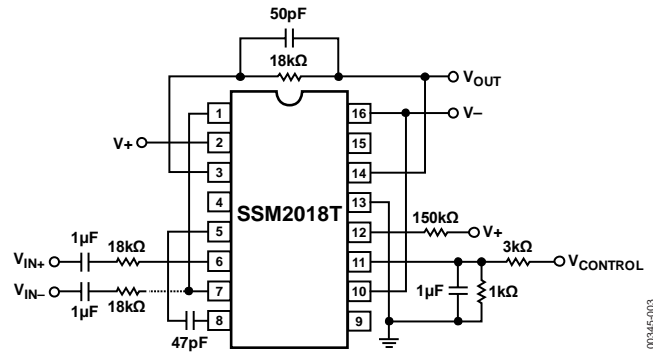

Figure 2. Typical Application Circuit

ESD CAUTION



ESD (electrostatic discharge) sensitive device. Charged devices and circuit boards can discharge without detection. Although this product features patented or proprietary protection circuitry, damage may occur on devices subjected to high energy ESD. Therefore, proper ESD precautions should be taken to avoid performance degradation or loss of functionality.

PIN CONFIGURATION AND FUNCTION DESCRIPTIONS

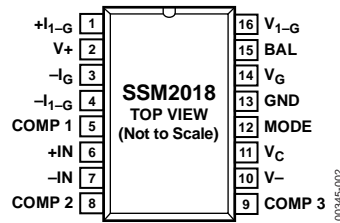

Figure 3.

Table 4. Pin Function Descriptions

Pin No.	Name	Description
1	+I _{1-G}	Positive Current Feedback Input for V _{1-G} .
2	V+	Positive Power Supply. Connect this pin directly to the positive power rail.
3	-I _G	Negative Current Feedback Input for V _G .
4	-I _{1-G}	Negative Current Feedback Input for V _{1-G} .
5	COMP1	Compensation Pin. Apply a capacitor to the COMPx pins according to the Compensating the SSM2018 section.
6	+IN	Non-Inverting Current Input.
7	-IN	Inverting Current Input.
8	COMP2	Compensation Pin. Apply a capacitor to the COMPx pins according to the Compensating the SSM2018 section.
9	COMP3	Compensation Pin. Apply a capacitor to the COMPx pins according to the Compensating the SSM2018 section.
10	V-	Negative Power Supply. Connect this pin directly to negative power rail.
11	V _c	Control Voltage Input Port. Apply voltage to control VCA according to the Control Section.
12	MODE	Operating Mode Pin. Selects Class A or Class AB operation as described in the Proper Operating Mode for the SSM2018 section.
13	GND	Ground.
14	V _G	Output Voltage at Gain of G.
15	BAL	Symmetry Trim Input for Older Version. Do not connect for SSM2108T operation.
16	V _{1-G}	Output Voltage at Gain of 1-G.

TYPICAL PERFORMANCE CHARACTERISTICS

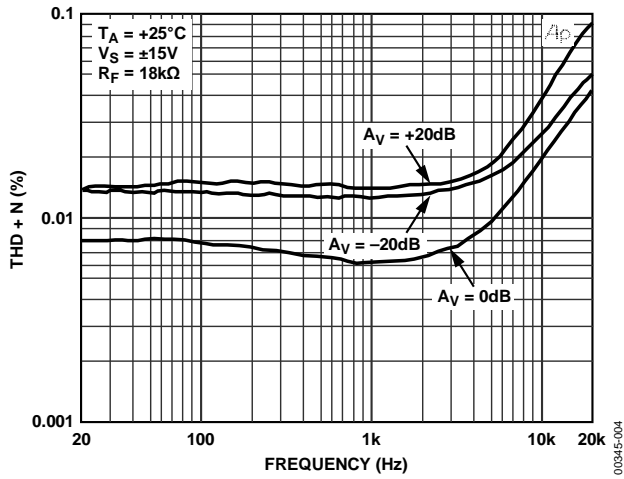

Figure 4. THD + N Frequency (80 kHz Low-Pass Filter, for $A_V = 0\text{ dB}$, $V_{IN} = 3\text{ V rms}$; for $A_V = +20\text{ dB}$, $V_{IN} = 0.3\text{ V rms}$; for $A_V = -20\text{ dB}$, $V_{IN} = 3\text{ V rms}$)

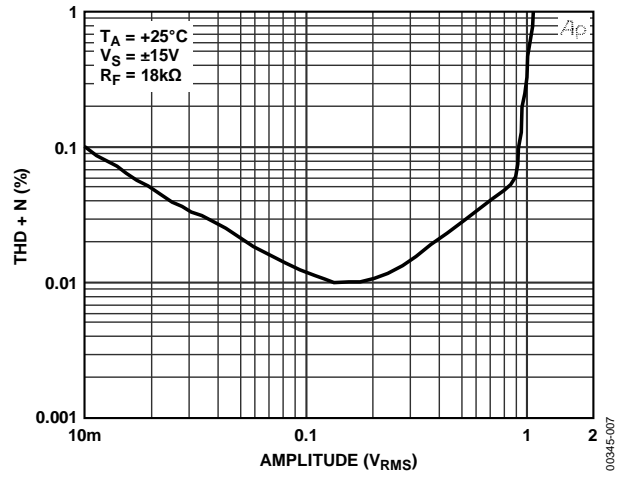

Figure 7. THD + N vs. Amplitude (Gain = +20 dB, $f_{IN} = 1\text{ kHz}$, 80 kHz Low-Pass Filter)

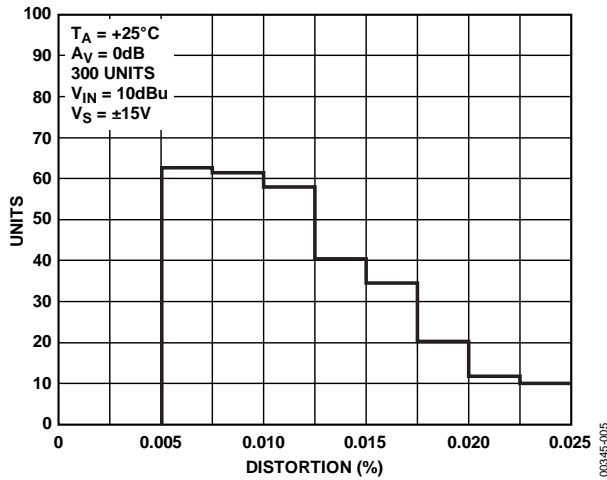

Figure 5. Distortion Distribution

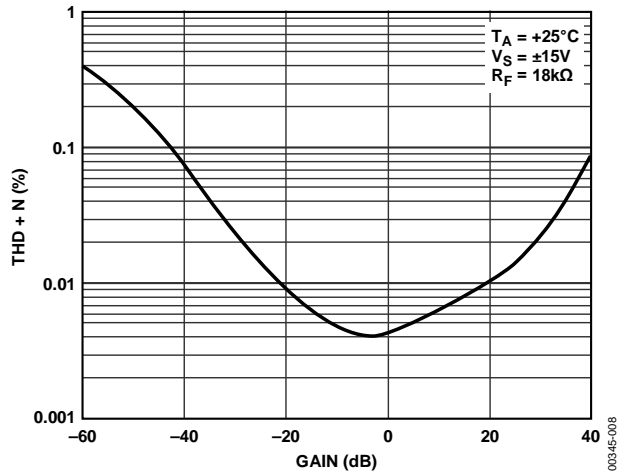

Figure 8. THD + N vs. Gain ($f_{IN} = 1\text{ kHz}$; for $-60\text{ dB} \leq A_V \leq -20\text{ dB}$, $V_{IN} = 10\text{ V rms}$; for $0\text{ dB} \leq A_V \leq +20\text{ dB}$, $V_{IN} = 1\text{ V rms}$)

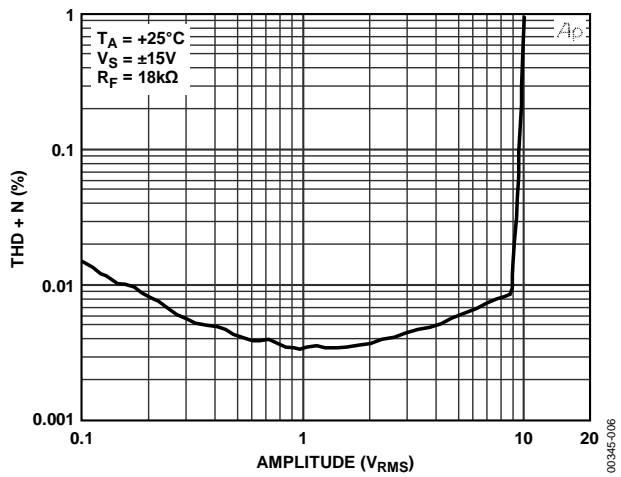

Figure 6. THD + N vs. Amplitude (Gain = 0 dB, $f_{IN} = 1\text{ kHz}$, 80 kHz Low-Pass Filter)

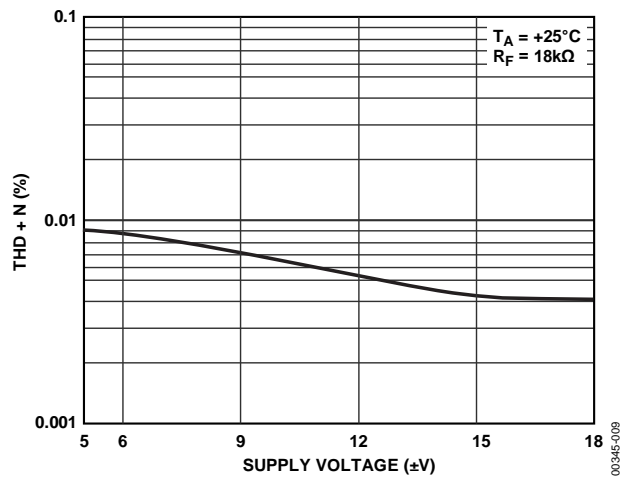

Figure 9. THD + N vs. Supply Voltage ($A_V = 0\text{ dB}$, $V_{IN} = 1\text{ V rms}$, $f_{IN} = 1\text{ kHz}$, 80 kHz Low-Pass Filter)

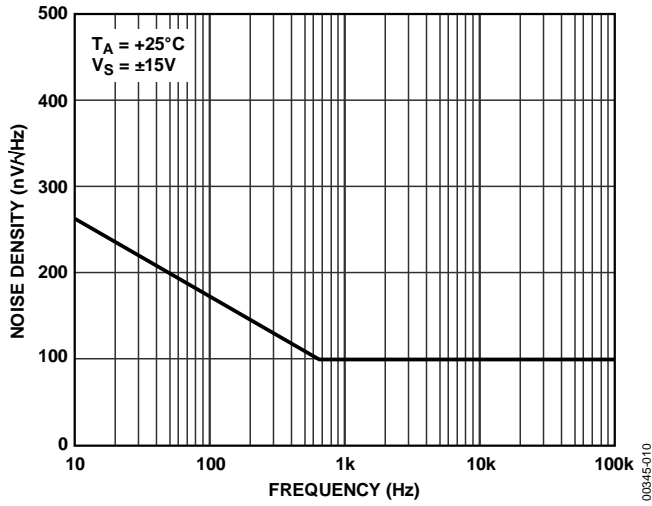

Figure 10. Noise Density vs. Frequency (Unity Gain, Referred to Input)

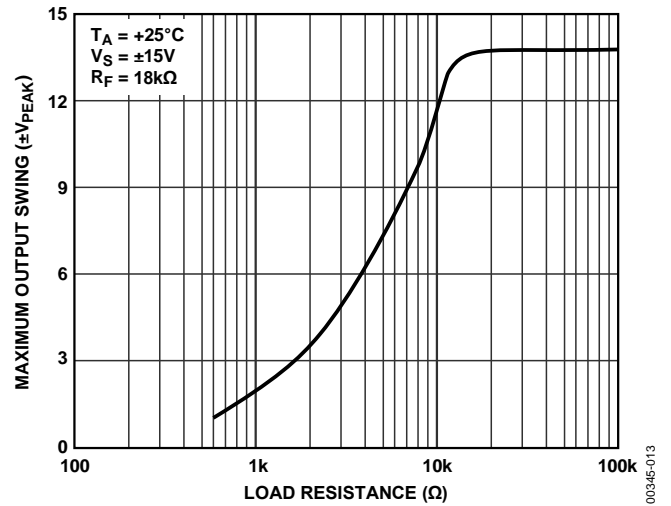

Figure 13. Maximum Output Swing vs. Load Resistance (THD = 1% Max)

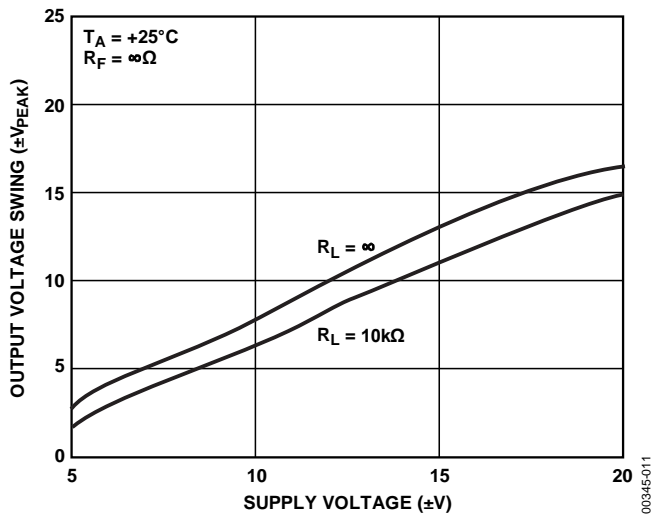

Figure 11. Maximum Output Swing vs. Supply Voltage (THD = 1% Max)

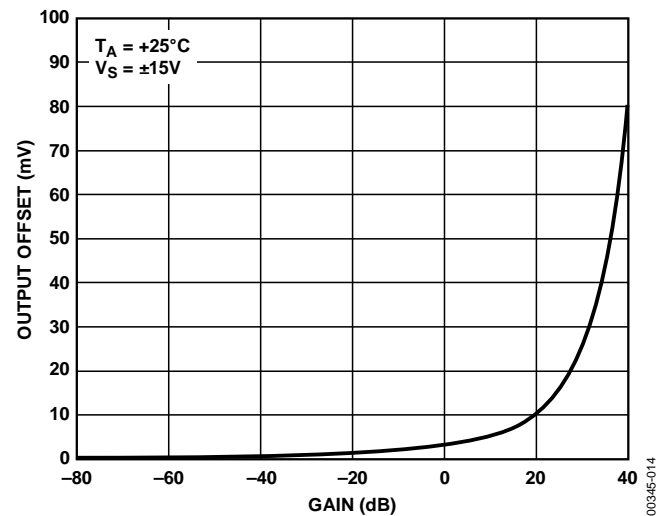

Figure 14. Typical Output Offset vs. Gain

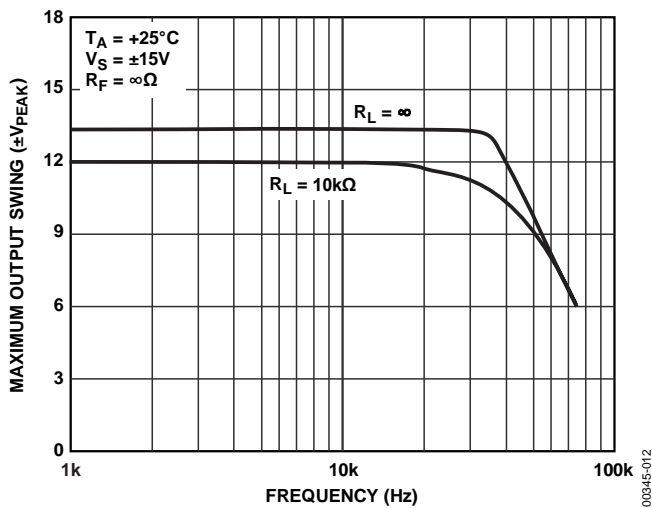

Figure 12. Maximum Output Swing vs. Frequency (THD = 1% Max)

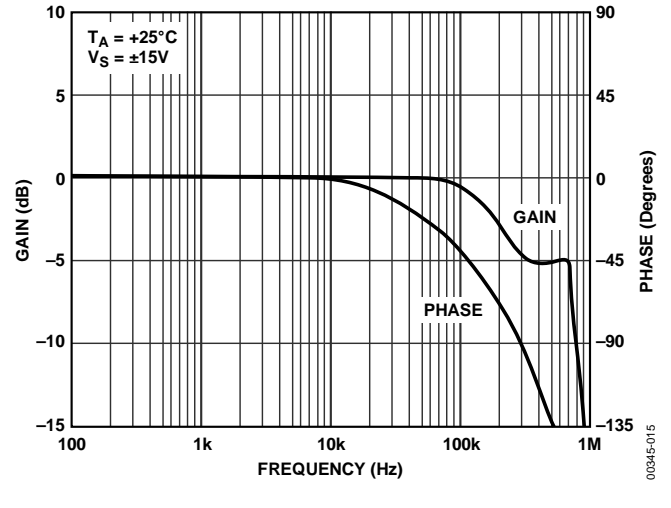

Figure 15. Gain and Phase vs. Frequency

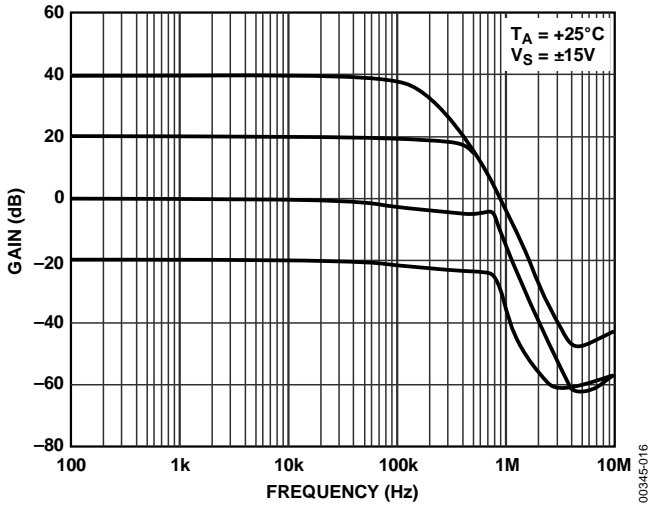

Figure 16. Gain vs. Frequency

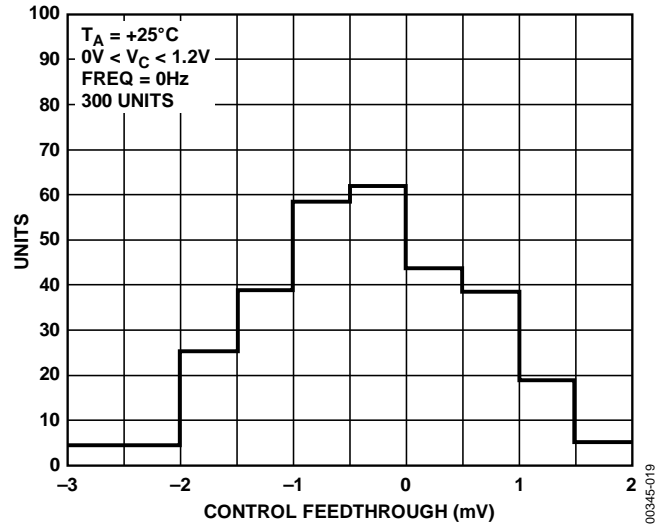

Figure 19. Control Feedthrough Distribution

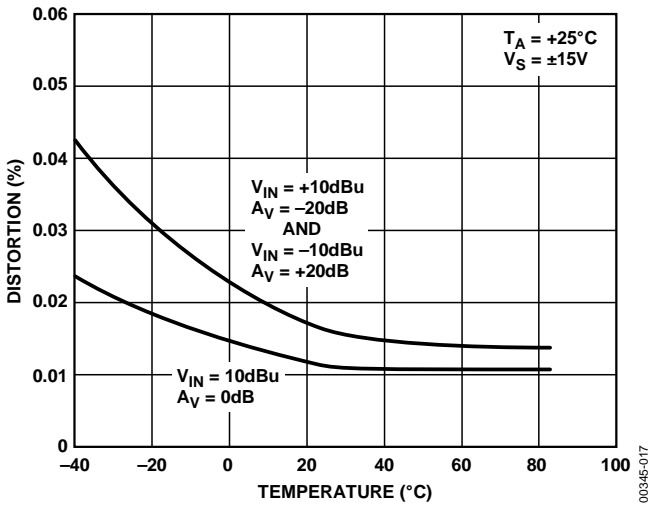

Figure 17. Distortion vs. Temperature

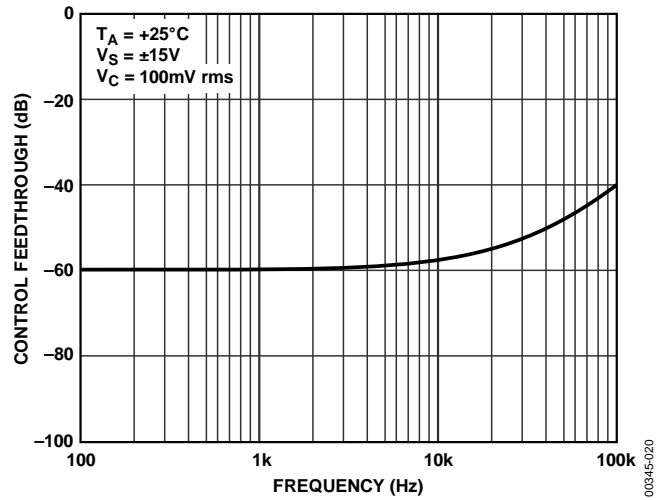

Figure 20. Control Feedthrough vs. Frequency

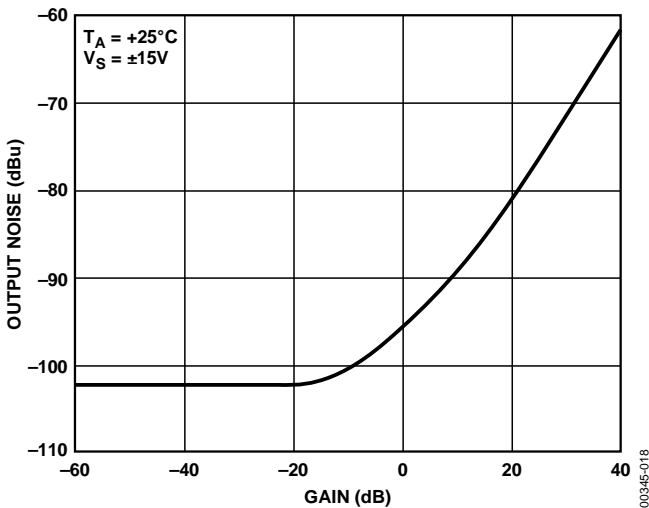

Figure 18. Output Noise vs. Gain ($V_{IN} = GND$, 20 kHz Bandwidth)

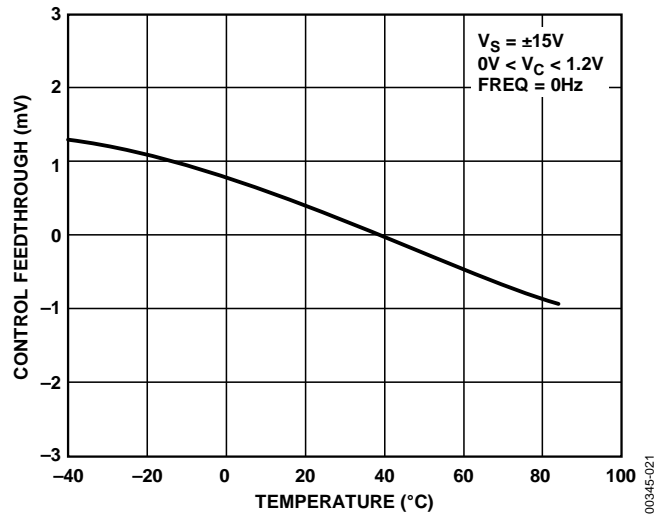

Figure 21. Control Feedthrough vs. Temperature

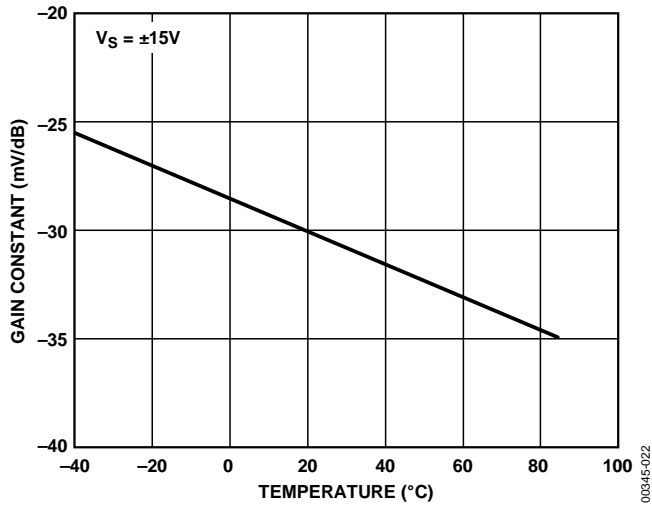

Figure 22. Gain Constant vs. Temperature

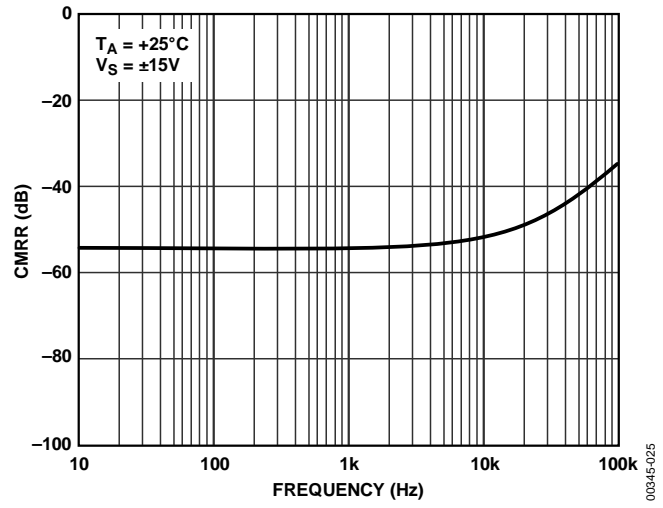

Figure 25. CMRR vs. Frequency

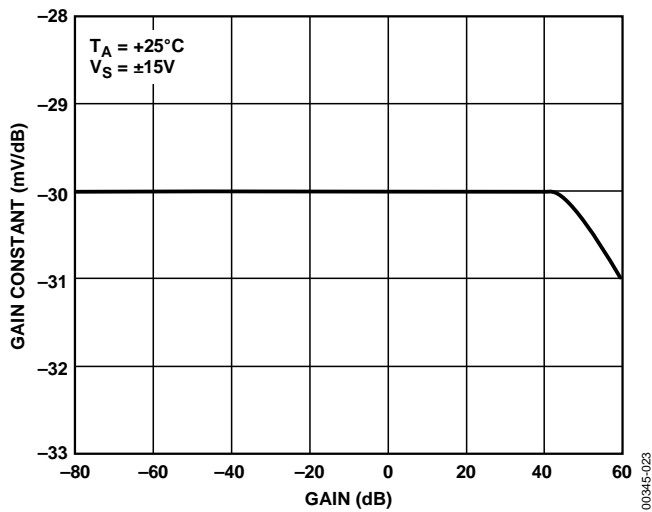

Figure 23. Gain Constant Linearity vs. Gain

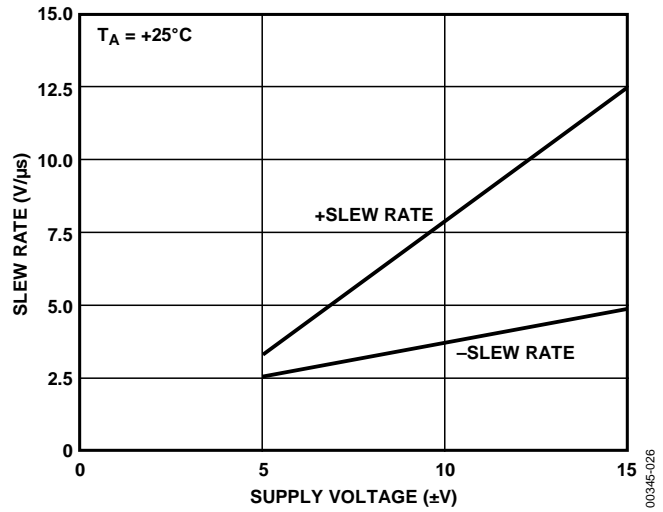

Figure 26. Slew Rate vs. Supply Voltage

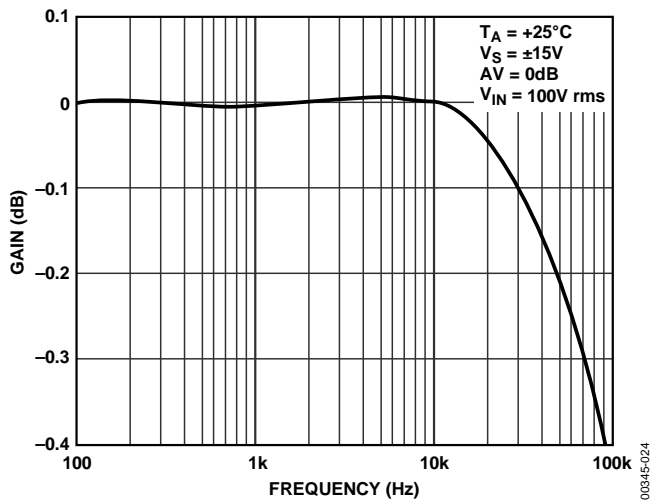

Figure 24. Gain Flatness vs. Frequency

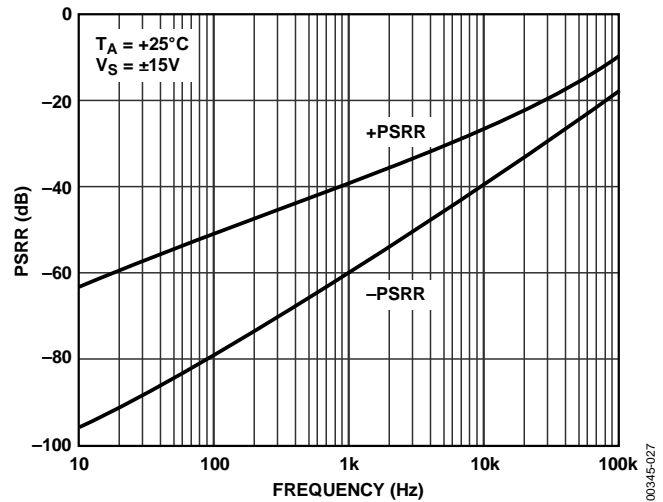

Figure 27. PSRR vs. Frequency

THEORY OF OPERATION

The **SSM2018** has the same internal circuitry as the original SSM2018. The detailed diagram in Figure 28 shows the main components of the VCA. The essence of the **SSM2018** is the gain core, which comprises two differential pairs (Q1–Q4). When the control voltage, V_C , is adjusted, current through the gain core is steered to one side or the other of the two differential pairs. The tail current for these differential pairs is set by the mode bias of the VCA (Class A or AB), which is labeled as I_M in the diagram. I_M is then modulated by a current proportional to the input voltage, labeled I_S . For a positive input voltage, more current is steered (by the splitter) to the left differential pair; the opposite is true for a negative input.

To understand how the gain control works, a simple example is best. Take the case of a positive control voltage on Pin 11. Note that the bases of Q2 and Q3 are connected to ground via a 200 Ω resistor. A positive control voltage produces a positive voltage on the bases of Q1 and Q4. Concentrating on the left-most differential pair, this raises the base voltage of Q1 above that of Q2. Thus, more of the tail current is steered through Q1 than through Q2. The current from the collector of Q2 flows through the external 18 k Ω feedback resistor around amplifier A3. When this current is reduced, the output voltage is also reduced. Thus, a positive control voltage results in an attenuation of the input signal, which explains why the gain constant is negative.

The collector currents of Q2 and Q3 produce the output voltage. The output of Q3 is mirrored by amplifier A1 to add to the overall output voltage. On the other hand, the collector currents of Q1 and Q4 are used for feedback to the differential inputs. Because Pins 6 and 4 are shorted together, any input voltage produces an input current which flows into Pin 4. The same is true for the inverting input, which is connected to Pin 1. The overall feedback ensures that the current flowing through the input resistors is balanced by the collector currents in Q1 and Q4.

COMPENSATING THE SSM2018

The **SSM2018** has a network that uses an adaptive compensation scheme that adjusts the optimum compensation level for a given gain. The control voltage not only adjusts the gain core steering, it also adjusts the compensation. The **SSM2018** has three compensation pins: COMP1, COMP2, and COMP3. COMP3 is normally left open. Grounding this pin actually defeats the adaptive compensation circuitry, giving the VCA a fixed compensation point. The only time this is desirable is when the VCA has fixed feedback, such as the voltage controlled panner (VCP) circuit shown later in the data sheet. Thus, for the Basic VCA circuit or the OVCE circuit, COMP3 should be left open.

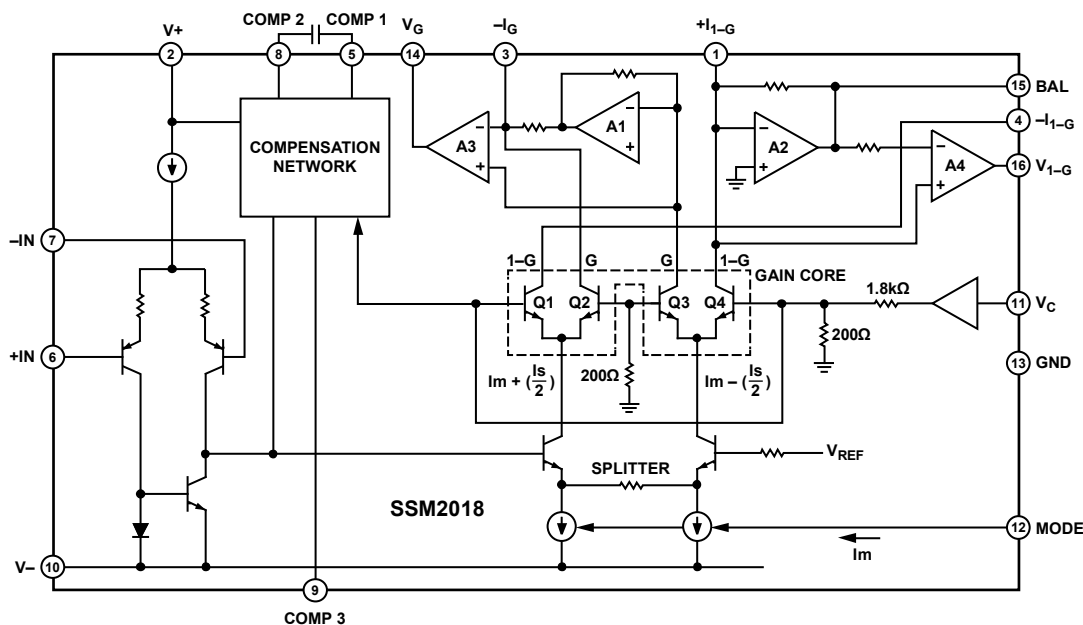

Figure 28. Detailed Functional Diagram

A compensation capacitor must be added between COMP1 and COMP2. Because the VCA operates over such a wide gain range, the compensation should ideally be optimized for each gain. When the VCA is in high attenuation, there is very high loop gain, and the part needs to have high compensation. On the other hand, at high gain, the same compensation capacitor would overcompensate the part and roll off the high frequency performance. Thus, the SSM2018 employs a patented adaptive compensation circuit. The compensation capacitor is Miller connected between the base and collector of an internal transistor. By changing the gain of this transistor via the control voltage, the compensation is changed.

Increasing the compensation capacitor causes the frequency response and slew rate to decrease, which tends to cause high frequency distortion to increase. For the basic VCA circuit, 47 pF was chosen as the optimal value. The OVCE circuit described later uses a 220 pF capacitor. The reason for the increase is to compensate for the extra phase shift from the additional output amplifier used in the OVCE configuration. The compensation capacitor can be adjusted over a practical range from 47 pF to 220 pF if desired. Below 47 pF, the parts may oscillate; above 220 pF the frequency response is significantly degraded.

CONTROL SECTION

As noted above, the control voltage on Pin 11 steers the current through the gain core transistors to set the gain. The unity gain (0 dB) condition occurs at $V_C = 0$. Attenuation occurs in the VCA for positive voltages (0 V to 3 V, typ), and gain occurs for negative voltage (0 V to -1.3 V, typ). From -1.3 V to +3.0 V, 140 dB of gain range is obtainable. The output gain formula is as follows:

$$V_{OUT} = V_{IN} \times e^{(-aV_C)} \quad (1)$$

The exponential term arises from the standard Ebers-Moll equation describing the relationship of a transistor's collector current as a function of the base-emitter voltage:

$$I_C = I_S \times e^{(V_{BE}/V_T)} \quad (2)$$

The factor a is a function not only of V_T but also the scaling due to the resistor divider of the 200 Ω and 1.8 k Ω resistors shown in Figure 2. The resulting expression for a is as follows: $a = 1/(10 \times V_T)$, which is approximately equal to 4 at room temperature. Substituting $a = 4$ in the above equation results in a -28.8 mV/dB control law at room temperature.

The -28.8 mV/dB number is slightly different from the data sheet specification of -30 mV/dB. The difference arises from the temperature dependency of the control law. The term V_T is known as the thermal voltage, and it has a direct dependency on temperature:

$$V_T = kT/q$$

where

k = Boltzmann's constant = 1.38 E - 23

q = electron charge = 1.6 E - 19

T = absolute temperature in Kelvin)

This temperature dependency leads to the -3500 ppm/ $^{\circ}$ C drift of the control law. It also means that the control law changes as the part warms up. Thus, our specification for the control law states that the part has been powered up for 60 seconds.

When the part is initially turned on, the temperature of the die is still at the ambient temperature (25 $^{\circ}$ C for example), but the power dissipation causes the die to warm up. With ± 15 V supplies and a supply current of 11 mA, 330 mW is dissipated. This number is multiplied by θ_{JA} to determine the rise in the die's temperature. In this case, the die increases from 25 $^{\circ}$ C to approximately 50 $^{\circ}$ C. A 25 $^{\circ}$ C temperature change causes a 8.25% increase in the gain constant, resulting in a gain constant of 30 mV/dB. The graph in Figure 22 shows how the gain constant varies over the full temperature range.

APPLICATIONS INFORMATION

The **SSM2018** is a trimless voltage controlled amplifier (VCA) for volume control in audio systems. The **SSM2018** is identical to the original SSM2018 in functionality and pinout; however, it is the first professional quality audio VCA in the marketplace that does not require an external trimming potentiometer to minimize distortion. Instead, the **SSM2018** is laser trimmed before it is packaged to ensure the specified THD and control feedthrough performance. This has a significant savings in not only the cost of external trimming potentiometers, but also the manufacturing cost of performing the trimming optimization during production.

BASIC VCA CONFIGURATION

The primary application circuit for the **SSM2018** is the basic VCA configuration, which is shown in Figure 29. This configuration uses differential current feedback to realize the VCA. A complete description of the internal circuitry of the VCA, and this configuration, is given in the Theory of Operation section. The **SSM2018** is trimmed at the factory for operation in the basic VCA configuration with class AB biasing. Thus, for optimal distortion and control feedthrough performance, use the same configuration and biasing. All of the graphs for the **SSM2018** in the data sheet have been measured using the circuit of Figure 29.

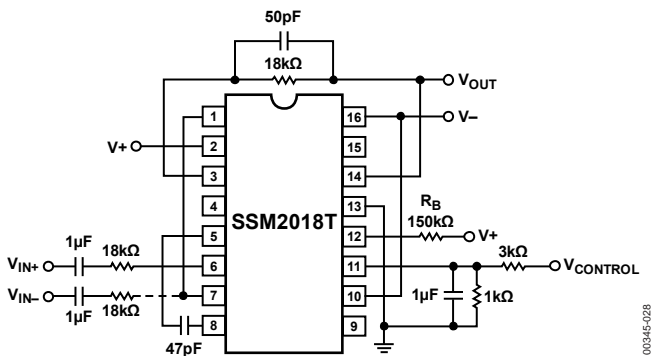

Figure 29. Basic VCA Application Circuit

In the simple VCA configuration, the **SSM2018** inputs are at a virtual ground. Thus, 18 kΩ resistors are required to convert the input voltages to input currents. The schematic also shows ac coupling capacitors. These are inserted to minimize dc offsets generated by bias current through the resistors. Without the capacitors, the dc offset due to the input bias current is typically 5 mV. The input stage has the flexibility to run either inverting, noninverting, or balanced. The most common configuration is to run it in the noninverting single-ended mode. If either input is unused, the associated 18 kΩ resistor and coupling capacitor should be removed to prevent any additional noise.

The common-mode rejection in balanced mode is typically 55 dB up to 1 kHz, decreasing at higher frequencies as shown in Figure 25. To ensure good CMRR in the balanced configuration, the input resistors must be balanced. For example, a 1% mismatch results in a CMRR of 40 dB. To achieve 55 dB, these resistors should have an absolute tolerance match of 0.1%.

The output of the basic VCA is taken from Pin 14, which is the output of an internal amplifier. Note that the second voltage output (Pin 16) is connected to the negative supply. This is normal and actually disables that output amplifier, ensuring that it does not oscillate and cause interference problems. Shorting the output to the negative supply does not cause the supply current to increase. This amplifier is only used in the OVCE application explained in the Operational Voltage Controlled Element section.

The control port follows a -30 mV/dB control law. The application circuit shows a 3 kΩ and 1 kΩ resistor divider from a control voltage. The choice of these resistors is arbitrary and could be any values to properly scale the control voltage. In fact, these resistors can be omitted if the control voltage has been properly scaled. The 1 μF capacitor is in place to provide some filtering of the control signal. Although the control feedthrough is trimmed at the factory, the feedthrough increases with frequency (Figure 20). Thus, high frequency noise can feed through and add to the noise of the VCA. Filtering the control signal helps minimize this noise source.

PROPER OPERATING MODE FOR THE SSM2018

The **SSM2018** has the flexibility of operating in either Class A or Class AB. This is accomplished by adjusting the amount of current flowing in the gain core (I_M in Figure 28). The traditional trade-off between the two classes is that Class A tends to have lower THD but higher noise than Class AB. However, by using well matched gain core transistors, distortion compensation circuitry and laser trimming, the **SSM2018** has excellent THD performance in Class AB. Thus, it offers the best of both worlds in having the low noise of Class AB with low THD.

Because the **SSM2018** operates optimally in Class AB, the distortion trim is performed for this class. To guarantee conformance to the data sheet THD specifications, the **SSM2018** must be operated in class AB. This does not mean that it can not be operated in Class A, but the optimal THD trim point is different for the two classes. Using Class A operation results to 0.05% without trim. An external potentiometer could be added to change the trim back to its optimal point as shown in the OVCE application circuit, but this adds the expense and time in adjusting a potentiometer.

The class of operation is set by selecting the proper value for R_B shown in Figure 29. R_B determines the current flowing into the MODE input (Pin 12). For class AB operation with ± 15 V supplies, R_B should be 150 kΩ. This results in a current of 95 μA. For other supply voltages, adjust the value of R_B such that current remains at 95 μA. This current follows the formula:

$$I_{MODE} = \frac{(V_{CC} - 0.7 \text{ V})}{R_B} \quad (3)$$

The factor of 0.7 V arises from the fact that the dc bias on Pin 12 is a diode drop above ground.

OUTPUT DRIVE

The SSM2018 is buffered by an internal op amp to provide a low impedance output. This output is capable of driving to within 1.2 V of either rail at 1% distortion for a 100 kΩ load. Note that this 100 kΩ load is in parallel with the feedback resistor of 18 kΩ, so the effective load is 15.3 kΩ. For better than 0.01% distortion, the output should remain about 3.5 V away from either rail as shown in Figure 6. As the graph of output swing versus load resistance shows (Figure 13), to maintain less than 1% distortion the output current should be limited to approximately ±1.3 mA. If higher current drive is required, the output should be buffered with a high quality op amp such as the ADA4897-1 or the AD797.

The internal amplifiers are compensated for unity gain stability and are capable of driving a capacitive load up to 4700 pF. Larger capacitive loads should be isolated from the output of the SSM2018 by the use of a 50 Ω series resistor.

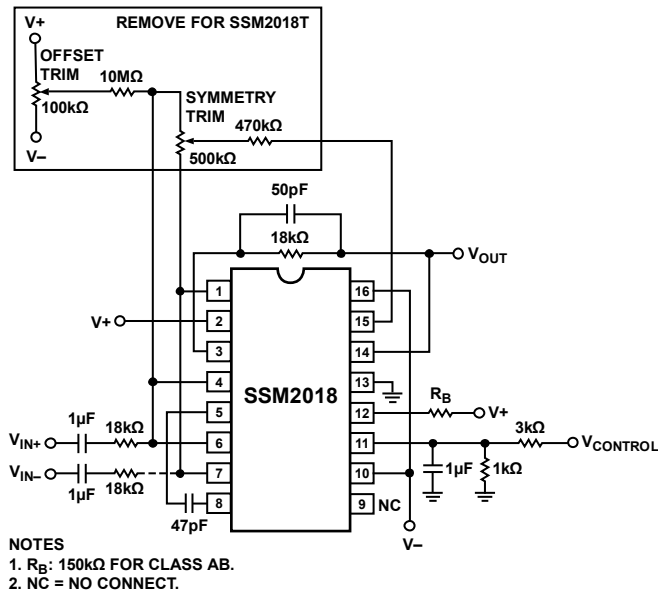

- NOTES
 1. R_B: 150kΩ FOR CLASS AB.
 2. NC = NO CONNECT.

Figure 30. Upgrading SSM2018 Sockets

UPGRADING SSM2018 SOCKETS

The SSM2018 easily replaces the SSM2018 in the basic VCA configuration. The parts are pin for pin compatible allowing direct replacement. At the same time, the trimming potentiometers for symmetry and offset should be removed, as shown in Figure 30. Upgrading immediately to the SSM2018 saves the expense of the potentiometers and the time in production of trimming for minimum distortion and control feedthrough.

If the SSM2018 is used in the OVCE or VCP configuration, the SSM2018 can still directly replace it; however, the potentiometers cannot necessarily be removed, as explained in the Operational Voltage Controlled Element and Voltage Controlled Panner sections.

TEMPERATURE COMPENSATION OF THE GAIN CONSTANT

The gain constant has a -3500 ppm/°C temperature drift due to the inherent nature of the control port. Over the full temperature range of -40°C to +85°C, the drift causes the gain to change by 7 dB if the part is in a gain of ±20 dB. If the application requires the gain constant to be the same over a wide temperature range, external temperature compensation should be employed. The simplest form of compensation is a temperature compensating resistor (TCR) such as the PT146 from Precision Resistor Co. These elements are different than a standard thermistor in that they are linear over temperature to better match the linear drift of the gain constant.

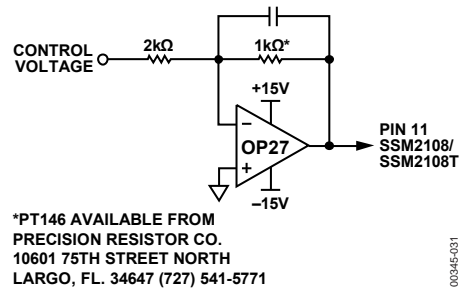

*PT146 AVAILABLE FROM
 PRECISION RESISTOR CO.
 10601 75TH STREET NORTH
 LARGO, FL. 34647 (727) 541-5771

Figure 31. Two TCRs Compensate for Temperature Drift of Gain Constant

The gain constant has a -3500 ppm/°C temperature drift that is due to the reciprocal dependence of the design on absolute temperature. This causes the gain to vary by 7 dB over the temperature range from -40°C to +85°C when the nominal gain at room temperature is set to 20 dB. The gain change is quite small if the temperature range of operation is restricted. Nevertheless, the TC of the gain constant is easily compensated by buffering the control voltage to the VCA with a circuit having a 3500 ppm/°C temperature coefficient. Figure 31 shows a simple solution to the problem using an op amp with a PT146 temperature compensating resistor from the Precision Resistor Company. Note that this circuit is inverting, which changes the gain constant to a positive quantity. Any other circuit that provides the necessary positive TC works.

DIGITAL CONTROL OF THE GAIN

A common method of controlling the gain of a VCA is to use a digital-to-analog converter to set the control voltage. Figure 32 shows a 12-bit DAC, the DAC8512, controlling the **SSM2018**. The DAC8512 is a complete 12-bit converter in an 8-pin package. It includes an on-board reference and an output amplifier to produce an output voltage from 0 V to 4.095 V, which is 1 mV/bit. Since the voltage is always positive, this circuit only provides attenuation. The resistor divider on the output of the DAC8512 is set to scale the output voltage so that full scale produces 80 dB of attenuation. The resistor divider can be adjusted to provide other attenuation ranges. If a parallel interface is needed, then the DAC8562 may be used or, for a dual DAC, the AD8582.

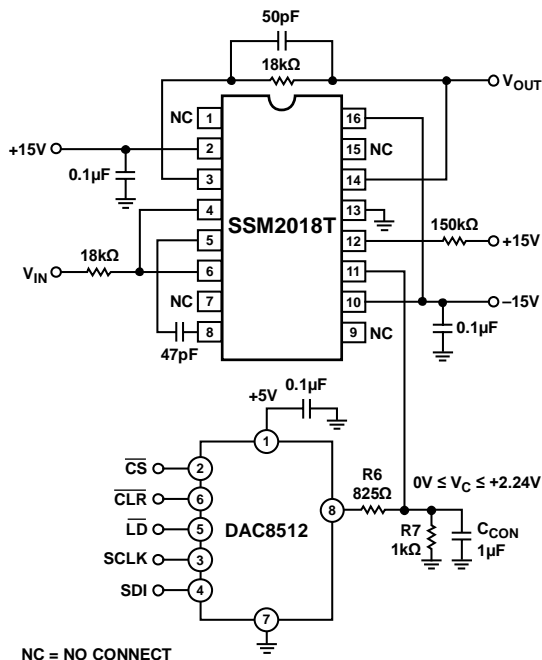

Figure 32. 12-Bit DAC Controls the VCA Gain

SUPPLY CONSIDERATIONS AND SINGLE-SUPPLY OPERATION

The **SSM2018** has a wide operating supply range. Many of the graphs in this data sheet show the performance of the part from ± 5 V to ± 18 V. These graphs offer typical performance specifications and are a good indication of the parts' capabilities. The minimum operating supply voltage is ± 4.5 V. Below this voltage, the parts are inoperable. Thus, to account for supply variations, the recommended minimum supply is ± 5 V.

For simplicity, the circuits in the data sheet do not show supply decoupling; however, to ensure best performance, each supply pin should be decoupled with a 0.1 μ F ceramic (or other low resistance and inductance type) capacitor as close to the package as possible. This minimizes the chance of supply noise feeding through the part causing excessive noise in the audio frequency range.

The **SSM2018** can be operated in single-supply mode as long as the circuit is properly biased. Figure 33 shows the proper configuration, which includes an amplifier to create a false ground node midway between the supplies. A high quality, wide bandwidth audio amplifier, such as the **ADA4897-1** or the **AD797**, should be used to ensure a very low impedance ground over the full audio frequency range. The minimum operating supply for the **SSM2018** is ± 5 V, which gives a minimum single-supply of +10 V and ground. The performance of the circuit with +10 V is identical to graphs that show operation of the **SSM2018** with ± 5 V supplies.

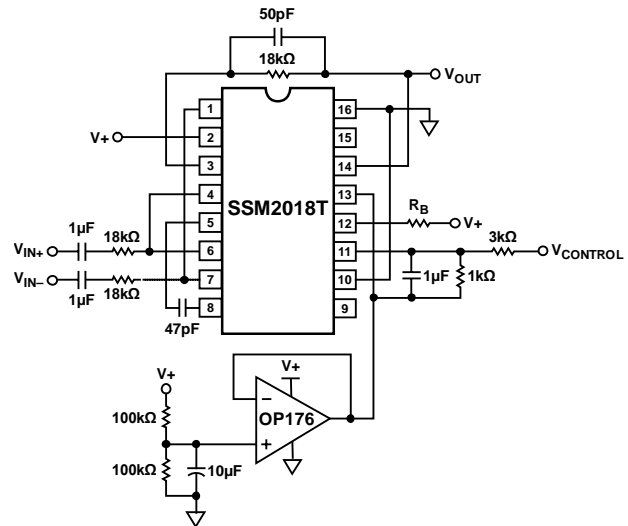

Figure 33. Single-Supply Operation of **SSM2018**

OPERATIONAL VOLTAGE CONTROLLED ELEMENT

The **SSM2018** has considerable flexibility beyond the basic VCA circuit utilized throughout this data sheet. The name operational voltage controlled element (OVCE) comes from the fact that the part behaves much like an operational amplifier with a second voltage controlled output. The symbol for the OVCE connected as a unity gain follower/VCA is shown in Figure 34. The voltage output labeled V_{1-G} is fed back to the inverting input as it is for an op amp's feedback. The V_G output is amplified or attenuated depending upon the control voltage.

Because the OVCE works similarly to an op amp, the feedback could as easily have included resistors to add gain, or a filter network to add frequency shaping. The full application circuit for the OVCE is shown in Figure 35. Note that the amplifier whose output (Pin 16) was originally connected to V_{MINUS} is now the output for feedback. As mentioned before, because the **SSM2018** is trimmed for the basic VCA configuration, potentiometers are needed for the OVCE configuration to ensure the best THD and control feedthrough performance.

If a symmetry trim is to be performed, it should precede the control feedthrough trim and be done as follows:

1. Apply a 1 kHz sine wave of 10 dBu to the input with the control voltage set for unity gain.
2. Adjust the symmetry trim potentiometer to minimize distortion of the output signal.

Next, the control feedthrough trim is done as follows:

1. Ground the input signal port and apply a 60 Hz sine wave to the control port. The sine wave should have its high and low peaks correspond to the highest gain to be used in the application and 30 dB of attenuation, respectively. For example, a range of 20 dB gain to 30 dB attenuation requires that the sine wave amplitude ranges between -560 mV and +840 mV on Pin 11.
2. Adjust the control feedthrough potentiometer to null the signal seen at the output.

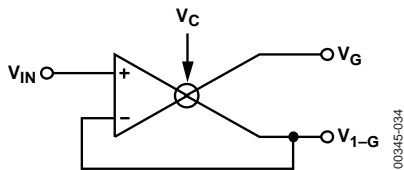
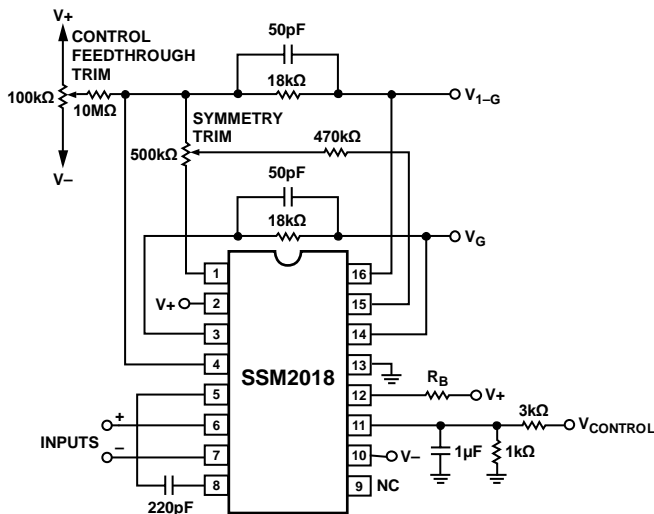

Figure 34. OVCE Follower/VCA Connection



- NOTES
1. $R_B = 30k\Omega$ FOR CLASS A.
 $150k\Omega$ FOR CLASS B.
 2. NC = NO CONNECT.

Figure 35. OVCE Application Circuit

VOLTAGE CONTROLLED PANNER

An interesting circuit that is built with the OVCE building block is a voltage controlled panner. Figure 36 shows the feedback connection for the circuit. Note that the average of both outputs is fed back to the input. Thus, the average must be equal to the input voltage. When the control voltage is set for gain at V_G , this causes V_{1-G} to attenuate (to keep the average the same). On the other hand, when V_G is attenuated, V_{1-G} is amplified. The result is that the control voltage causes the input to pan from one output to the other. The following expressions show how this circuit works mathematically:

$$V_G = 2K \times V_{IN} \text{ and } V_{1-G} = 2(1 - K) \times V_{IN} \quad (4)$$

where K varies between 0 and 1 as the control voltage is changed from full attenuation to full gain, respectively.

When $V_C = 0$, then $K = 0.5$ and $V_G = V_{1-G} = V_{IN}$. Again, trimming is required for best performance. Pin 9 must be grounded. This is possible because the feedback is constant and the adaptive network is not needed. The VCP is the only application shown in this data sheet where Pin 9 is grounded.

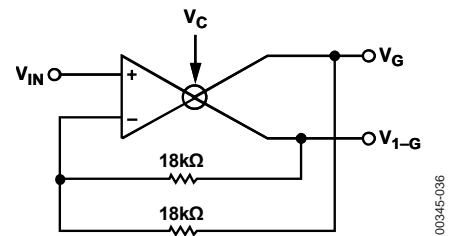
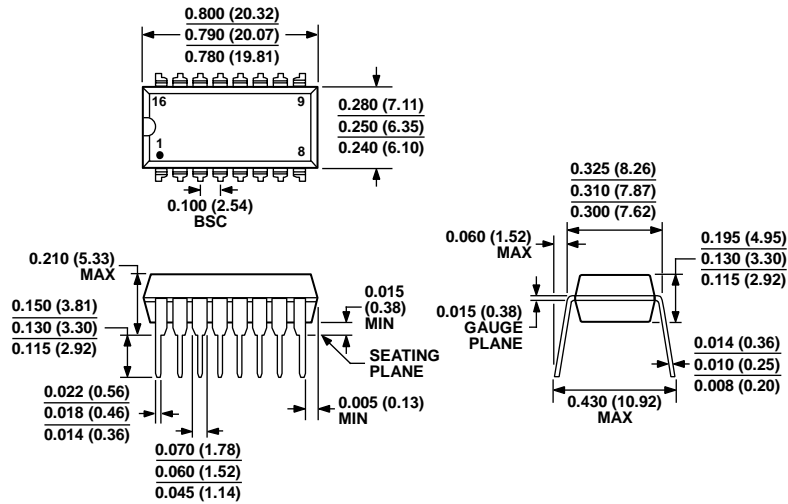

Figure 36. Basic VCP Connection

OUTLINE DIMENSIONS



COMPLIANT TO JEDEC STANDARDS MS-001-AB

CONTROLLING DIMENSIONS ARE IN INCHES; MILLIMETER DIMENSIONS (IN PARENTHESES) ARE ROUNDED-OFF INCH EQUIVALENTS FOR REFERENCE ONLY AND ARE NOT APPROPRIATE FOR USE IN DESIGN. CORNER LEADS MAY BE CONFIGURED AS WHOLE OR HALF LEADS.

Figure 37. 16-Lead Plastic Dual In-Line Package [PDIP]

Narrow Body
(N-16)

Dimensions shown in inches and (millimeters)

073106-B

ORDERING GUIDE

Model ¹	Temperature Range	Package Description	Package Option
SSM2018PZ	-40°C to +85°C	16-Lead Plastic Dual In-Line Package [PDIP]	N-16
SSM2018TPZ	-40°C to +85°C	16-Lead Plastic Dual In-Line Package [PDIP]	N-16

¹ Z = RoHS Compliant Part.