

## Adaptive synchronous rectification controller for LLC resonant converter

Datasheet - production data

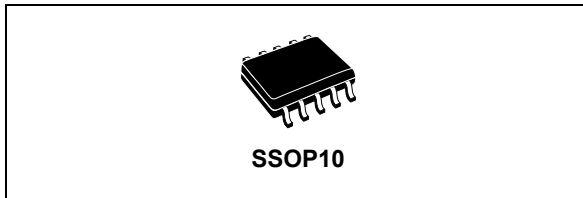

- 80+/85+ compliant ATX SMPS
- 90+/92+ compliant SERVER SMPS
- Industrial SMPS

### Description

The SRK2001 controller implements a control scheme specific for secondary side synchronous rectification in LLC resonant converters that use a transformer with center tap secondary winding for full wave rectification.

It provides two high current gate drive outputs, each capable of driving one or more N-channel power MOSFETs. Each gate driver is controlled separately and an interlock logic circuit prevents the two synchronous rectifier MOSFETs from conducting simultaneously.

The control scheme in this IC provides for each synchronous rectifier being switched on as the corresponding half-winding starts conducting and switched off as its current goes to zero.

The innovative turn-on logic with adaptive masking time and the adaptive turn-off logic allows maximizing the conduction time of the SR MOSFETs eliminating the need of the parasitic inductance compensation circuit.

The low consumption mode of the device allows to meet the most stringent requirement for converter power consumption in light-load/no load conditions.

A noticeable feature is the very low external component count required.

### Features

- Secondary side synchronous rectification controller optimized for LLC resonant converter
- Dual gate driver for N-channel MOSFETs
- Adaptive turn-off logic
- Turn-on logic with adaptive masking time
- Auto-compensation of parasitic inductance
- Low consumption mode: 50  $\mu$ A quiescent current
- $V_{CC}$  operating voltage range 4.5 to 32 V
- High voltage drain-to-source Kelvin sensing for each SR MOSFET
- Operating frequency up to 500 kHz
- 35 ns total delay at turn-off
- Protection against current reversal
- Safe management of load transient, light-load and startup conditions
- Intelligent automatic sleep mode at light-load with user programmable enter/exit load levels, with soft transitions and function disable
- Programmable exit load levels from burst mode
- Compatible with standard and logic level MOSFETs: SRK2001 and SRK2001L
- SSOP10 package

### Applications

- AC-DC adapters
- All-in -one PC
- High-end flat panel TV

**Table 1. Ordering codes**

Package	Packing	Standard gate MOSFETs	Logic gate MOSFETs
SSOP10	Tube	SRK2001	SRK2001L
	Tape and reel	SRK2001TR	SRK2001LTR

# Contents

- 1      Block diagrams and pin connections ..... 3**
- 2      Maximum ratings ..... 5**
- 3      Typical application schematic ..... 6**
- 4      Electrical characteristics ..... 7**
- 5      Operation description ..... 9**
  - 5.1 Drain voltage sensing ..... 9
  - 5.2 Turn-on ..... 9
  - 5.3 Turn-off ..... 11
  - 5.4 ZCD comparator ..... 12
  - 5.5 Gate drive ..... 13
  - 5.6 Intelligent automatic sleep mode ..... 13
  - 5.7 EN and PROG pins: function and usage ..... 14
    - 5.7.1 Automatic sleep mode function enabled ..... 15
    - 5.7.2 Automatic sleep mode function disabled ..... 16
  - 5.8 Layout guidelines ..... 16
- 6      Package information ..... 18**
  - SSOP10 package information. .... 19
- 7      Revision history ..... 21**

# 1 Block diagrams and pin connections

Figure 1. Internal block diagram

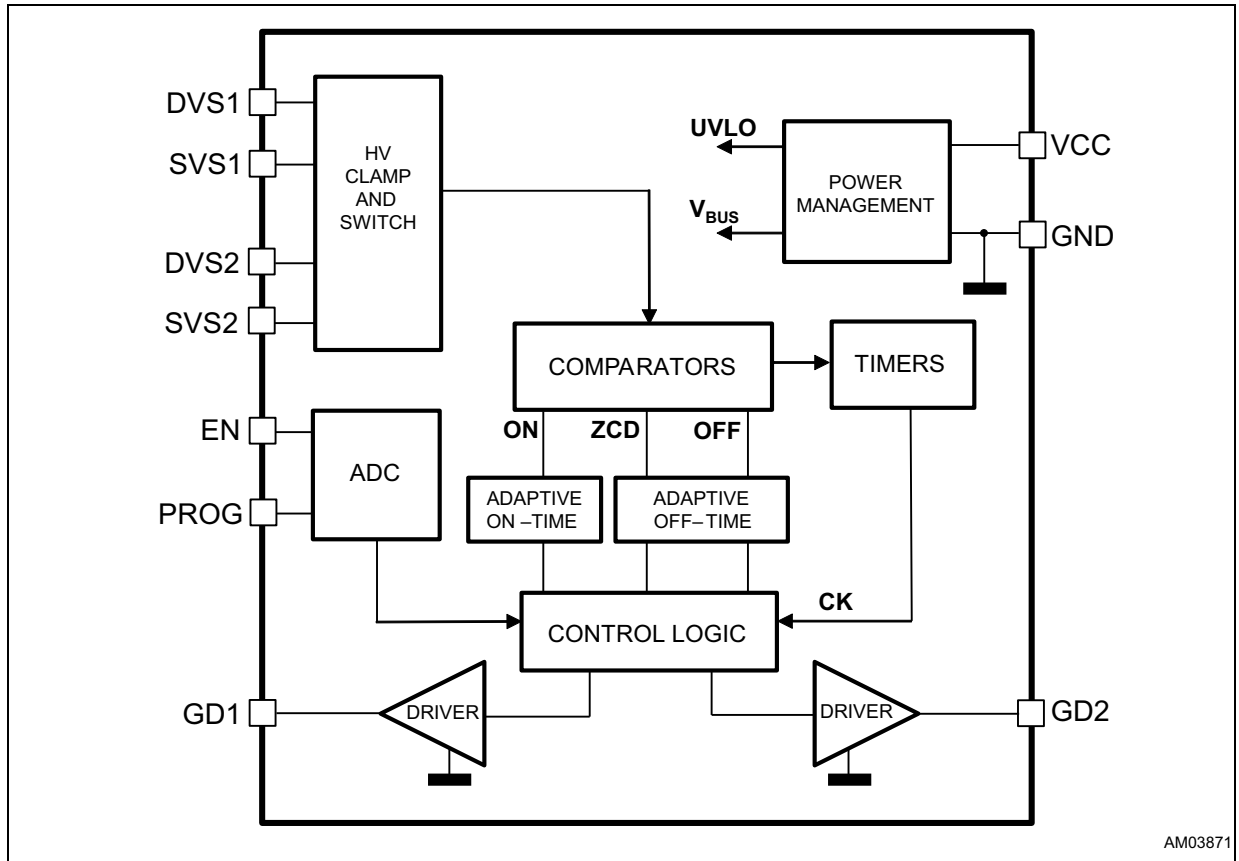

Figure 2. Typical system block diagram

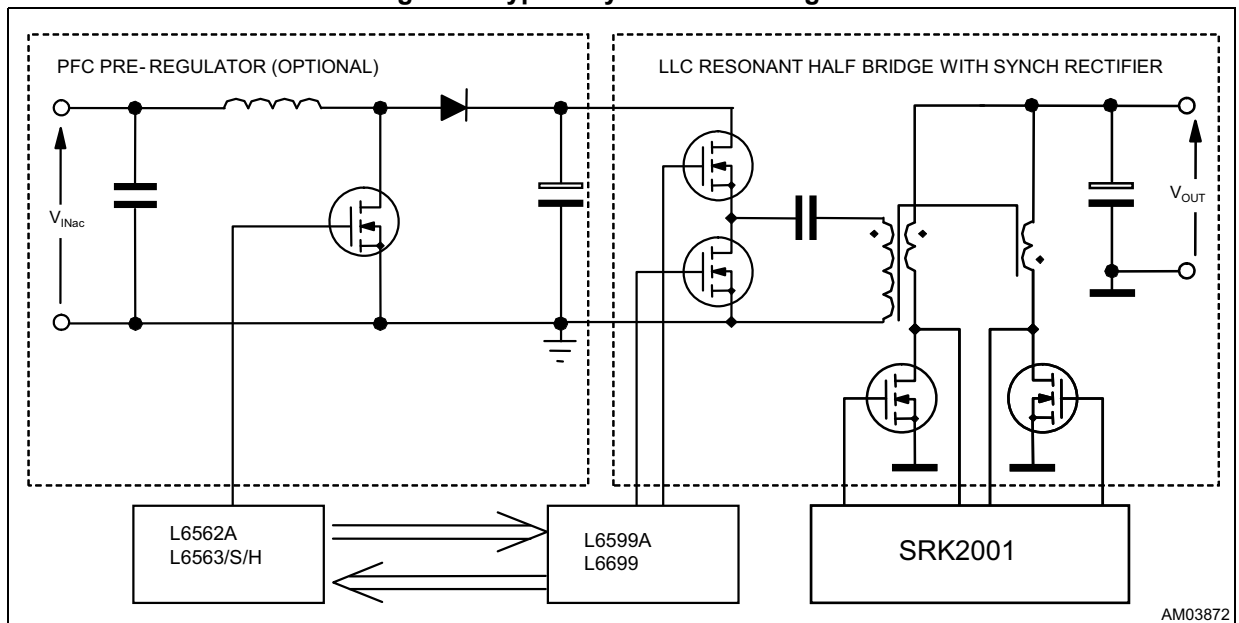

Figure 3. Pin connections (top view)

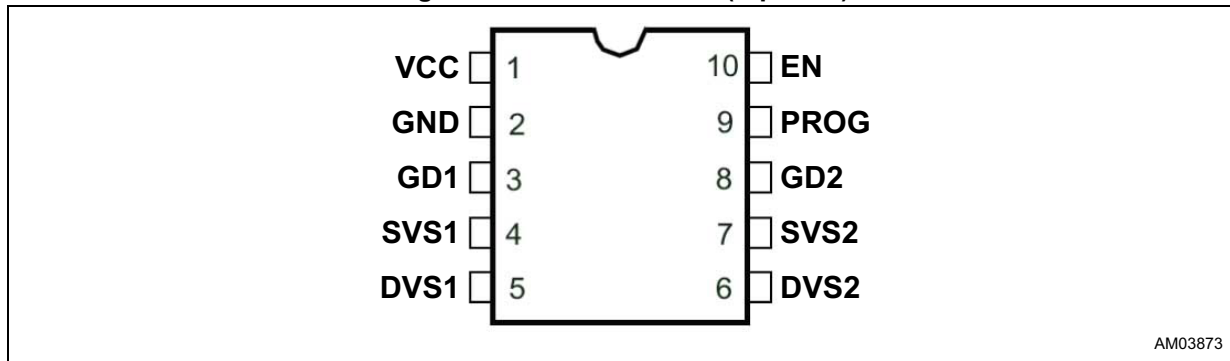

Table 2. Pin functions

No.	Name	Function
1	VCC	Supply voltage of the device. A bypass capacitor to GND, located as close to IC's pins as possible, helps to get a clean supply voltage for the internal control circuitry and acts as an effective energy buffer for the pulsed gate drive currents.
2	GND	Return of the device bias current and return of the gate drive currents. Route this pin to the common point where the source terminals of both synchronous rectifier MOSFETs are connected.
3 (8)	GD1 (GD2)	Gate driver output for section 1 (2). Each totem pole output stage is able to drive power MOSFETs with high peak current levels. To avoid excessive gate voltages in case the device is supplied with a high V <sub>CC</sub> , the high level voltage of these pins is clamped to about 11 V or 5.5 V (typ. value), depending on the selected part number, to allow for the proper driving of standard or logic level MOSFETs. The pin has to be connected directly to the SR MOSFET gate terminal.
4 (7)	SVS1 (SVS2)	Source voltage sensing for section 1 (2): it is the reference voltage of the corresponding drain sensing signal on the DVS1, 2 pin. These pins have to be connected directly to the respective source terminals of the corresponding synchronous rectifier MOSFET.
5 (6)	DVS1 (DVS2)	Drain voltage sensing for section 1 (2). These pins have to be connected to the respective drain terminals of the corresponding synchronous rectifier MOSFET using a series resistor at least of 100 Ω.
9	PROG	Programming pin for conduction duty cycle at sleep mode entering/exiting. A resistor connected from this pin to GND, supplied by an internal precise current source, sets a voltage V <sub>PROG</sub> ; depending on this voltage level, during the startup phase, the user can chose, according to the application requirements, the proper sleep mode or burst mode exiting the conduction duty cycle among the ones contained into two internal lookup tables (the values are predefined inside <a href="#">Table 6 on page 15</a> , <a href="#">Table 7 on page 16</a> and <a href="#">Table 8 on page 16</a> ). See <a href="#">Table 5</a> or the proper choice of resistor value.
10	EN	Enable pin function with internal pull-up and current source capability: <ul style="list-style-type: none"> <li>– Automatic sleep mode function enable/disable: the sleep mode is disabled if the pin voltage is detected above an internal threshold (V<sub>SM_off</sub>) during the startup phase.</li> <li>– Remote ON/OFF: during run the mode, when the pin voltage is sensed below the internal threshold V<sub>EN_OFF</sub>, the controller stops operating and enters a low consumption state; it resumes the operation if the pin voltage surpasses the threshold V<sub>EN_ON</sub>.</li> <li>– During the startup phase, the pin voltage level allows to select the predefined conduction duty cycle for sleep mode entering. A resistor connected from this pin to GND, supplied by an internal precise current source allows the user for this choice (two predefined values). See the <a href="#">Table 5</a> for the proper choice of resistor value.</li> </ul>

## 2 Maximum ratings

**Table 3. Absolute maximum ratings**

Symbol	Pin	Parameter	Value	Unit
$V_{CC}$	1	DC supply voltage	-0.3 to $V_{CCZ}$	V
$I_{CCZ}$	1	Internal Zener maximum current ( $V_{CC} = V_{CCZ}$ )	25	mA
$V_{PROG}$	10	PROG pin voltage rating	-0.3 to 3.3	V
$V_{EN}$	9	EN pin voltage rating	-0.3 to 3.3	V
DVS1, 2	5, 6	Drain sense voltage referred to source SVS1, 2	-3 to 90	V
SVS1, 2	4, 7	Source sense voltage referred to GND	-3 to 3	V

Stressing the device above the rating listed in [Table 3](#) may cause permanent damage to the device. Exposure to absolute maximum rated conditions may affect device reliability.

**Table 4. Thermal data**

Symbol	Parameter	Value	Unit
$R_{th\ j-amb}$	Max. thermal resistance, junction to ambient <sup>(1)</sup>	130	°C/W
$R_{th\ j-case}$	Max thermal resistance, junction to case top <sup>(1)</sup>	10	°C/W
$P_{tot}$	Power dissipation at $T_{amb} = 50\text{ °C}$	0.75	W
$T_j$	Junction temperature operating range	-40 to 150	°C
$T_{stg}$	Storage temperature	-55 to 150	°C

1. With the pin 2 soldered to a dissipating copper area of 25 mm<sup>2</sup>, 35 µm thickness (PCB material FR4 1.6 mm thickness).

### 3 Typical application schematic

Figure 4. Typical application schematic

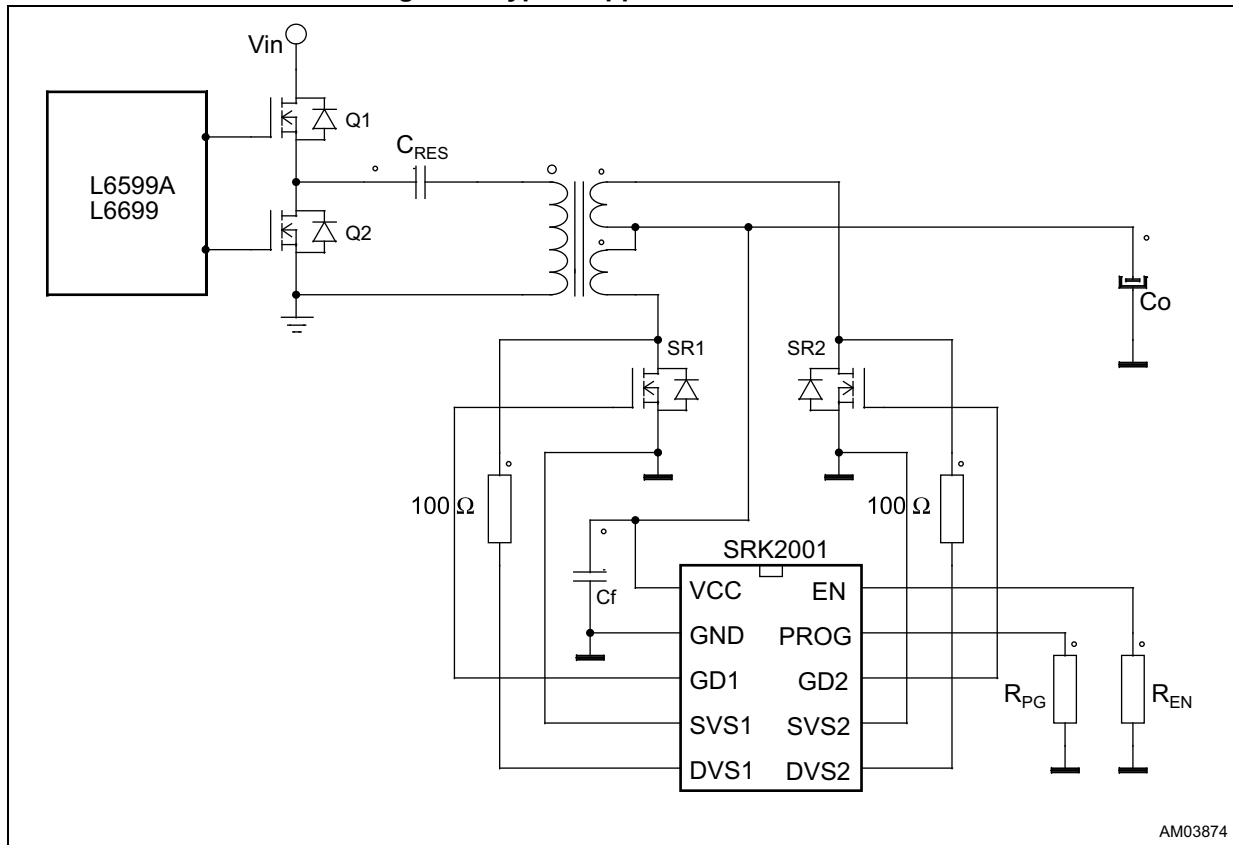

AM03874

## 4 Electrical characteristics

**Table 5. Electrical characteristics ( $T_j = -25$  to  $125$  °C,  $V_{CC} = 12$  V,  $C_{GD1} = C_{GD2} = 4.7$  nF,  $R_{EN} = 100$  k $\Omega$ ;  $R_{PG} = 0$   $\Omega$ ; unless otherwise specified; typical values refer to  $T_j = 25$  °C)**

Symbol	Parameter	Test condition	Min.	Typ.	Max.	Unit
<b>Supply section</b>						
$V_{CC}$	Operating range	After turn-on	4.5		32	V
$V_{CC\_On}$	Turn-on supply voltage	See <sup>(1)</sup>	4.25	4.5	4.75	V
$V_{CC\_Off}$	Turn-off supply voltage	See <sup>(1)</sup>	4	4.25	4.5	V
Hys	Hysteresis			0.25		V
$V_{CCZ}$	Clamp voltage	$I_{CCZ} = 20$ mA	33	36	39	V
$I_{q\_run}$	Current consumption in run mode	After turn-on (excluding SR MOS gate capacitance charging/discharging) at 100 kHz		700		$\mu$ A
$I_{CC}$	Operating supply current	At 300 kHz		35		mA
$I_q$	Quiescent current	Low consumption mode operation, with DVS1, 2 pins not switching <sup>(2)</sup> , $T_j = -25$ °C to $85$ °C		50	65	$\mu$ A
<b>Drain-source sensing INPUTS and SYNCH functions</b>						
$V_{DS1,2}$	Drain-to-source sensing operating voltage				90	V
$V_{TH\_A}$	Arming voltage	Positive-going edge		1.4		V
$V_{TH\_PT}$	Pre-triggering voltage	Negative-going edge		0.7		V
$V_{TH\_ON}$	Turn-on threshold	Negative-going edge	-130	-100	-70	mV
$T_{diode\_off}$	Body diode residual conduction time after turn-off			75		ns
$T_{D\_On\_min}$	Minimum turn-on delay			100		ns
$T_{D\_On\_max}$	Maximum turn-on delay	At 100 kHz		2		$\mu$ s
<b>Enable pin remote ON/OFF function</b>						
$V_{EN\_OFF}$	Disable threshold	<sup>(1)</sup> Negative-going edge during run mode	0.25	0.3	0.35	V
$V_{EN\_ON}$	Enable threshold	<sup>(1)</sup> Positive-going edge during run mode	0.45	0.62	0.82	V
$I_{EN\_run}$	Sourced current	During run mode	4	6	8	$\mu$ A
<b>Automatic sleep mode programming</b>						
$D_{OFF}$	Min. operating duty cycle to enter sleep mode	$R_{EN} = 100$ k $\Omega$ 1%		40		%
		$R_{EN} = 180$ k $\Omega$ 1%		25		
$D_{ON}$	Restart duty cycle from sleep mode with $R_{EN} = 100$ k $\Omega$ 1%	$R_{PG} = 0$ $\Omega$		80		%
		$R_{PG} = 100$ k $\Omega$ 1%		75		
		$R_{PG} = 180$ k $\Omega$ 1%		65		
		$R_{PG}$ open		60		

**Table 5. Electrical characteristics ( $T_j = -25$  to  $125$  °C,  $V_{CC} = 12$  V,  $C_{GD1} = C_{GD2} = 4.7$  nF,  $R_{EN} = 100$  k $\Omega$ ;  $R_{PG} = 0$   $\Omega$ ; unless otherwise specified; typical values refer to  $T_j = 25$  °C) (continued)**

Symbol	Parameter	Test condition	Min.	Typ.	Max.	Unit
$D_{ON}$	Restart duty cycle from sleep mode with $R_{EN} = 180$ k $\Omega$ 1%	$R_{PG} = 0$ $\Omega$		75		%
		$R_{PG} = 100$ k $\Omega$ 1%		70		
		$R_{PG} = 180$ k $\Omega$ 1%		60		
		$R_{PG}$ open		55		
<b>Burst mode exiting programming</b>						
$D_{ON\_BM}$	Restart duty cycle with EN pin open at startup during primary burst mode operation	$R_{PG} = 0$ $\Omega$		80		%
		$R_{PG} = 100$ k $\Omega$ 1%		75		
		$R_{PG} = 180$ k $\Omega$ 1%		65		
		$R_{PG}$ open		0		
$I_{PROG}$	Sourced current	<sup>(1)</sup> At $V_{CC}$ startup	9	10	11	$\mu$ A
<b>Gate drivers</b>						
$I_{source\_pk}$	Output source peak current	See <sup>(3)</sup>		-0.35		A
$I_{sink\_pk\_ZCD}$	Max. output sink peak current	ZCD comparator triggered turn-off <sup>(3)</sup>		4		A
$t_r$	Rise time			140		ns
$t_f$	Fall time (OFF comparator)	OFF comparator triggered turn-off		80		ns
$t_{f\_ZCD}$	Fall time (ZCD comparator)	ZCD comparator triggered turn-off		30		ns
$V_{GDclamp}$	Output clamp voltage	$I_{GD} = -5$ mA; $V_{CC} = 20$ V; SRK2001/TR	9	11	13	V
		$I_{GD} = -5$ mA; $V_{CC} = 20$ V; SRK2001L/LTR		5.5		V
$V_{GDL\_UVLO}$	UVLO saturation	$V_{CC} = 0$ to $V_{CC\_On}$ , $I_{sink} = 5$ mA		1	1.3	V

- Parameters tracking each other.
- The low consumption mode is one of the following: the automatic sleep mode, converter burst mode detect or the EN pin pulled low.
- Parameter guaranteed by design.



## 5 Operation description

The device block diagram is shown in [Figure 1 on page 3](#). The SRK2001 can be supplied through the VCC pin by the same converter output voltage, within a wide voltage range (from 4.5 V to 32 V), internally clamped to  $V_{CCZ}$  (36 V typical). An internal UVLO (undervoltage lockout) circuit with hysteresis keeps the device switched off at supply voltage lower than the turn-on level  $V_{CC\_On}$ , with reduced consumption. After the startup, the operation with  $V_{CC}$  floating (or disconnected by supply voltage) while pins DVS1, 2 are already switching is not allowed: this in order to avoid that a  $dV/dt$  on the DVS pin may cause a high flowing current with possible damage of the IC.

The core of the device is the control logic block, implemented by asynchronous logic: this digital circuit generates the logic signals to the output drivers, so that the two external power MOSFETs are switched on and off, depending on the evolution of their drain-source voltages, sensed on the DVS-SVS pin pairs through the comparators block.

The logic that controls the driving of the two SR MOSFETs is based on two gate driver state machines working in parallel in an interlocked way to avoid switching on both gate drivers at the same time. A third state machine manages the transitions from the normal operation to the sleep mode and vice versa.

### 5.1 Drain voltage sensing

The SRK2001 basic operation is such that each synchronous rectifier MOSFET is switched on whenever the corresponding transformer half-winding starts conducting (i.e.: when the MOSFET body diode, or an external diode in parallel, starts conducting) and it is then switched off when the flowing current approaches zero. To understand the polarity and the level of this current, the IC is provided with two pairs of pins (DVS1 - SVS1 and DVS2 - SVS2) that sense the drain-source voltage of either MOSFET (Kelvin sensing). In order to limit dynamic current injection in any condition, at least 100  $\Omega$  resistors in series to DVS1, 2 pins must be used.

Referring to the typical waveforms in [Figure 5](#), there are three significant voltage thresholds: the first one,  $V_{TH\_A}$  (= 1.4 V), sensitive to positive-going edges, arms the opposite gate driver (interlock function); the second one  $V_{TH\_PT}$  (= 0.7 V), sensitive to negative-going edges provides a pre-trigger of the gate driver; the third one  $V_{TH\_ON}$  is the (negative) threshold that triggers the gate driver as the body diode of the SR MOSFET starts conducting.

### 5.2 Turn-on

The turn-on logic is such that each SR MOSFET is switched on when the sensed drain-source voltage goes below the  $V_{TH\_ON}$  threshold: to avoid false triggering of the gate driver, an adaptive masking delay  $T_{D\_On}$  is introduced. This delay assumes a minimum value at the high load and increases with decreasing load levels. The aim of  $T_{D\_On}$  is to avoid a premature turn-on at lower load conditions, triggered by capacitive currents (due to secondary side parasitic) and not really related to the current flowing through the body diode.

Figure 5. Typical waveforms

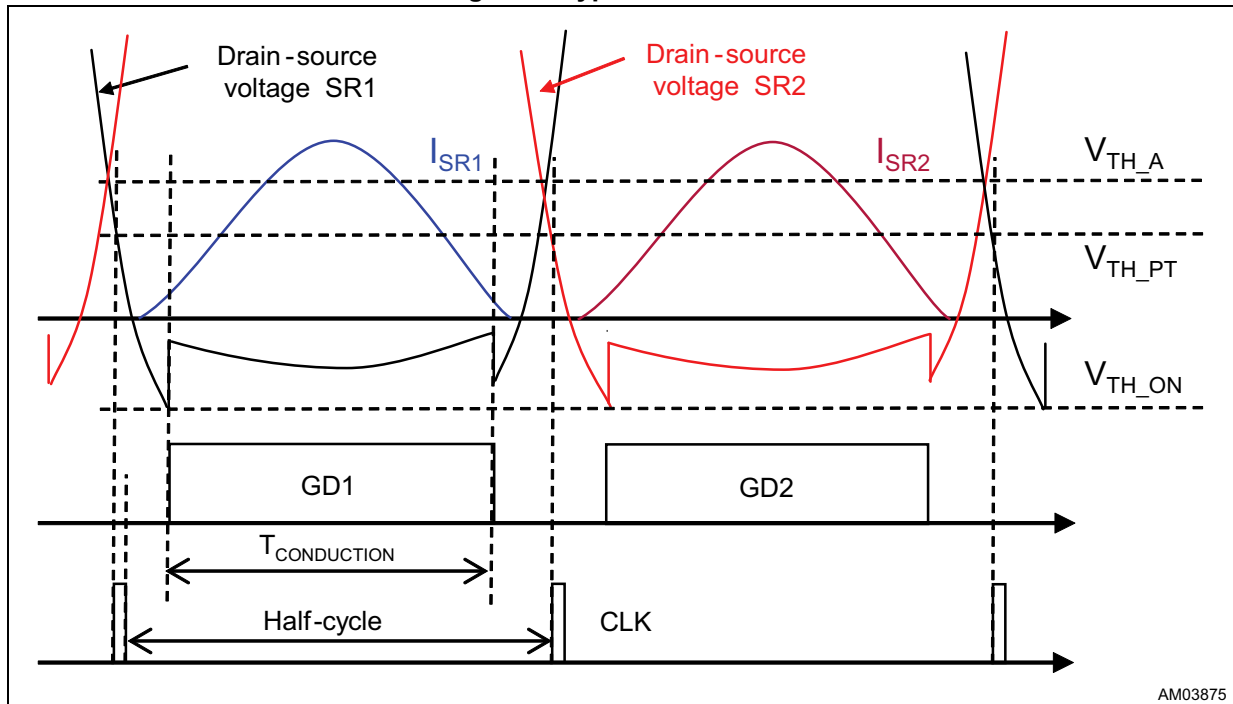

Figure 6 shows the effect of this parasitic capacitance: in case at the reduced load a capacitive current spike should trigger the turn-on, there would be a current inversion (flowing from the output capacitor toward the SR MOSFET) causing a discharge of the output capacitor and consequently a necessary increase of the rms rectified current, in order to balance that discharge and this, in turn, would impair efficiency too. Therefore, the adaptive turn-on delay is aimed to maximize the efficiency in each load operating condition. Figure 7 shows the turn-on at the full load with minimum delay ( $T_{D\_On\_min}$ ) and at the reduced load with increased delay (up to  $T_{D\_On\_max}$  equal to 40% of the clock cycle).

Figure 6. Capacitive current spike effect at turn-on

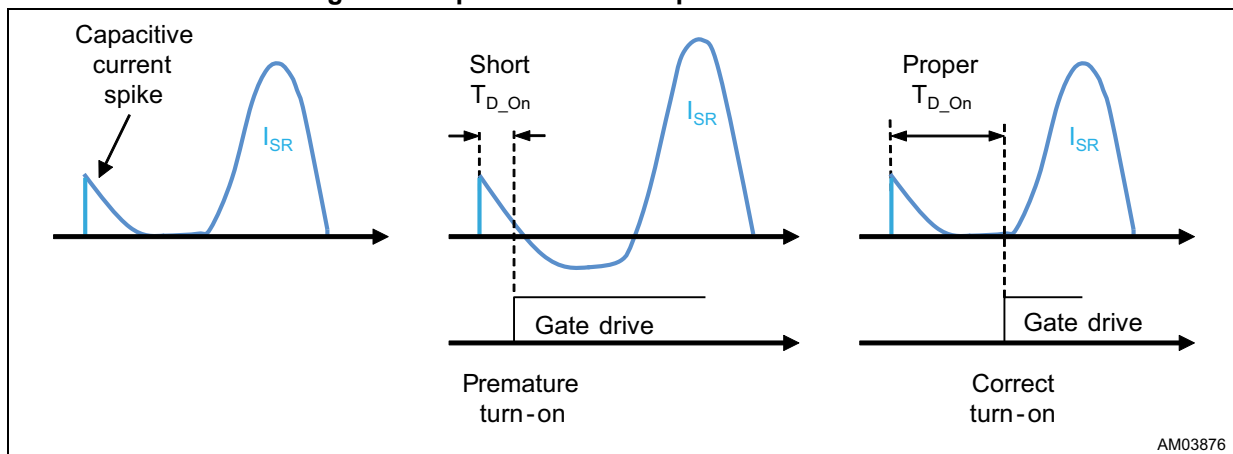
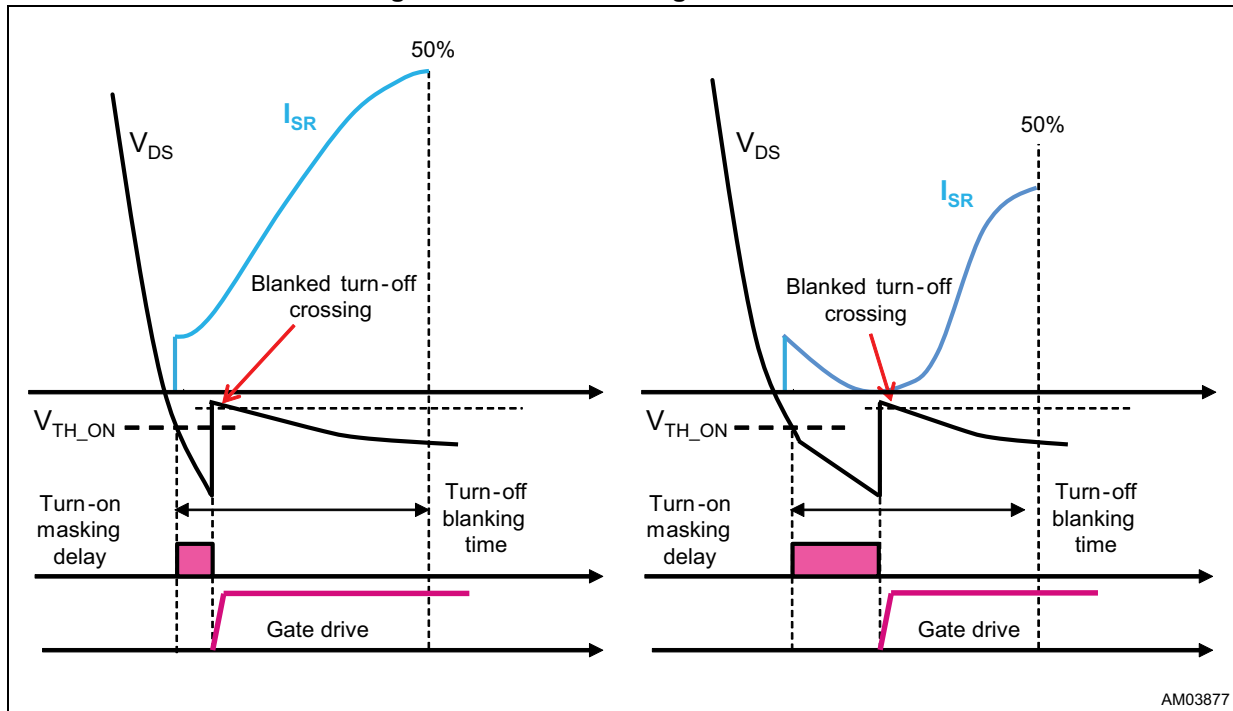

Figure 7. Full load and light-load turn-on



At the start-up and on sleep mode exiting, the control circuit starts with a turn-on delay set to 30% of the clock cycle and progressively adapts it to the proper value. This allows reducing system perturbation both during the start-up and while exiting the sleep mode during a fast zero to full load transition. After the turn-on, a blanking time (equal to 50% of the clock period) masks an undesired turn-off due to the drain-source voltage drop, consequent to MOSFET switch on (flowing current passes from the body diode to MOSFET channel resistance).

### 5.3 Turn-off

The SR MOSFET turn-off may be triggered by an adaptive turn-off mechanism (two slope turn-off) or by the ZCD\_OFF comparator (fast turn-off, see [Section 5.4](#)).

Due to the stray inductance in series with the SR MOSFET  $R_{DS(on)}$  (mainly the package stray inductance), the sensed drain-source signal is not really equal to the voltage drop across the MOSFET  $R_{DS(on)}$ , but it anticipates the time instant where the current reaches zero, causing a premature MOSFET turn-off.

To overcome this problem (without adding any stray inductance compensation circuit), the device uses a turn-off mechanism based on an adaptive algorithm that turns off the SR MOSFET when the sensed drain voltage reaches zero adapting progressively the turn-off to the maximum conduction period.

Figure 8. Adaptive turn-off

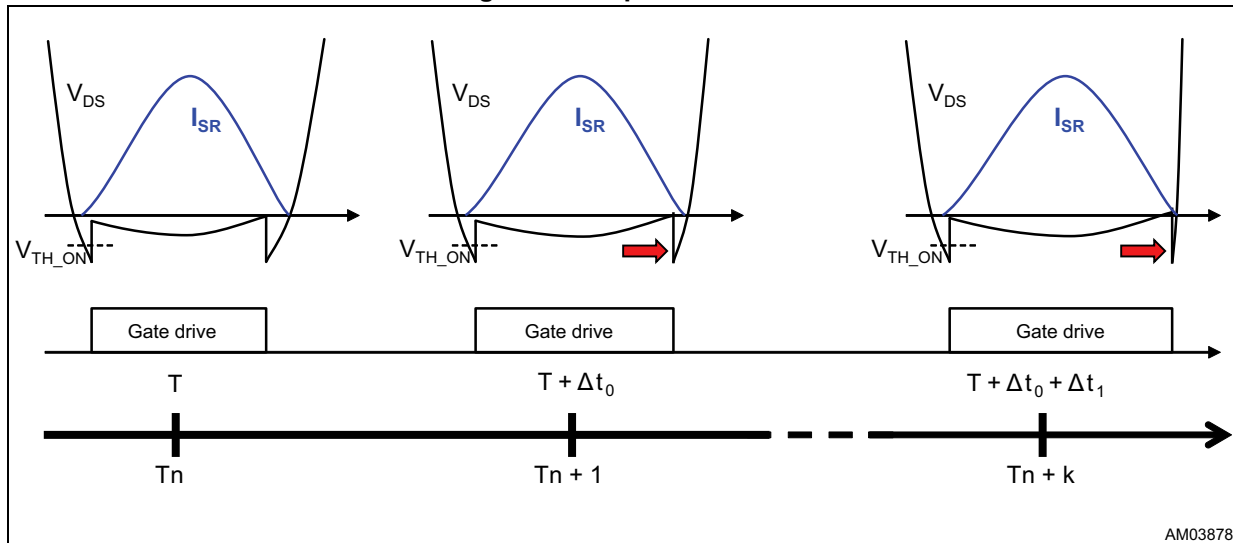

Figure 8 shows this adaptive algorithm: cycle-by-cycle the conduction time is maximized allowing in a steady-state the maximum converter efficiency.

During the start-up and on sleep mode exiting, the control circuit turns off the SR MOSFET at 50% of the clock cycle and progressively adapts this delay in order to maximize the SR MOSFET conduction time. This helps reducing system perturbations.

## 5.4 ZCD comparator

The IC is equipped with a ZCD comparator that is always ready to quickly turn-off the SR MOSFETs, avoiding in this way current inversion, that would cause SR MOSFETs failure and even half bridge destruction, in case of the primary controller not equipped with proper protections.

The ZCD (zero current detection) comparator acts during fast load transitions or the short-circuit operation and when the above resonance operation occurs. It senses that the current has reached the zero level and triggers the gate drive circuit for a very fast MOSFET turn-off (with a total delay time  $T_{D\_Off}$ ).

The ZCD comparator threshold is not fixed but self-adaptive.

In the steady-state load operation and in case of slow load transitions, the turn-off is prevalently managed by the adaptive mechanism (characterized by the two slope turn-off driving). Instead, during fast transitions or during above resonance operation, the ZCD\_OFF comparator will take over, causing a fast MOSFET switch-off that prevents undesired current inversions.

The ZCD\_OFF comparator is blanked for 450 ns after the turn-on.

Depending on SR MOSFET choice, some premature turn-off triggered by the ZCD\_OFF comparator may be found due to the noise present on the drain-source sensed signal: this is worse with lower  $R_{DS\_ON}$  (due to worse signal to noise ratio) and lower stray inductance of the MOSFET package. Normally the load level where this may happen is such that the circuit has already entered a low consumption state (for example in burst mode from primary controller); if this is not the case, some noise reduction may be helpful, for example by using RC snubbers across the SR MOSFETs drain-source.

## 5.5 Gate drive

The IC is provided with two high current gate drive outputs, each capable of driving one or more N-channel power MOSFETs in parallel.

According to the selected part number, it is possible to drive both standard and logic level MOSFETs: the high level voltage provided by the driver is clamped at  $V_{GDclamp}$  (11 V typ. for the SRK2001 and 5.5 V typ. for the SRK2001L) to avoid excessive voltage levels on the gate in case the device is supplied with a high  $V_{CC}$ , thus minimizing the gate charge provided in each switching cycle.

The two gate drivers have a pull-down capability that ensures the SR MOSFETs cannot be spuriously turned on even at low  $V_{CC}$ : in fact, the drivers have a 1 V (typ.) saturation level at  $V_{CC}$  below the turn-on threshold.

As described in the previous paragraphs, either the SR MOSFET is switched on after the current starts flowing through the body diode, when the drain-source voltage is already low (equal to  $V_F$ ); therefore there is no Miller effect nor switching losses at the MOSFET turn-on, in which case the drive doesn't need to provide a fast turn-on. Also at the turn-off, during steady-state load conditions, when the decision depends on the adaptive control circuitry, there is no need to have a very fast drive with hard pull-down, because the current has not yet reached zero and the operation is far from the current inversion occurrence. Moreover, slow transitions also help reducing the perturbation introduced into the system that arise due to the MOSFET turn-on and turn-off, contributing to improve the overall behavior of the LLC resonant converter.

On the other side, during very fast load transitions or the short-circuit operation, when the turn-off decision is taken by ZCD logic, the MOSFET turn-off needs to be very fast to avoid current inversion: therefore the two gate drivers are designed to guarantee for a very short turn-off total delay  $T_{D\_Off}$ .

In order to avoid current inversions, SRK2001 stops driving SR MOSFETs during any operating condition where the converter enters deeply into the below resonance region (i.e.: switching frequency gets lower than 60% of resonance frequency).

## 5.6 Intelligent automatic sleep mode

A unique feature of this IC is its intelligent automatic sleep mode. The logic circuitry is able to detect a light-load condition for the converter and stop gate driving, reducing also IC's quiescent consumption. This improves converter's efficiency at the light-load, where the power losses on the rectification body diodes (or external diodes in parallel to the MOSFETs) become lower than the power losses in the MOSFETs and those related to their driving. The IC is also able to detect an increase of the converter's load and automatically restarts gate driving.

The algorithm used by the intelligent automatic sleep mode is based on a dual time measurement system: the duration of the half-switching period (i.e.: the clock cycle in [Figure 5 on page 10](#)) and the duration of the conduction time of the synchronous rectifier.

The duration of a clock cycle is measured from the falling edge of a clock pulse to the rising edge of the subsequent clock pulse; the duration of the SR MOSFET conduction is measured from the moment its body diode starts conducting (drain-source voltage falling below  $V_{TH-ON}$ ) to the moment the gate drive is turned off, in case the device is operating, or to the moment the body diode ceases to conduct (drain-to-source voltage going above  $V_{TH-ON}$ ) during the sleep mode operation. While at the full load the SR MOSFET conduction time

occupies almost 100% of the half-switching cycle, as the load is reduced, the conduction duty cycle is reduced and, as it falls below  $D_{OFF}$  (see data in [Table 5 on page 7](#)), the device enters the sleep mode. To prevent wrong decisions, the sleep mode condition must be confirmed for 512 consecutive clock cycles.

Once in the sleep mode, SR MOSFET gate driving is re-enabled when the conduction duty cycle of the body diode (or the external diodes in parallel to the MOSFET) exceeds  $D_{ON}$ : the number of clock cycles needed to exit the sleep mode is proportional to the difference between the body diode conduction duty cycle and the programmed  $D_{ON}$  threshold. This allows a faster sleep-out in case of the heavy load transient low-to-high.

Furthermore, in order to reduce the perturbation introduced by a sudden sleep mode state entering, a soft-sleep transition procedure is adopted, that progressively decreases the conduction time before entering the sleep mode state.

After entering the sleep mode, timing is ignored for 8 switching cycles respectively to let the resulting transient in the output current fade-out, then the timing check is enabled.

The automatic sleep mode function can be disabled by the EN pin (see [Section 5.7](#)): this may be beneficial to the overall system behavior in case of conflict with the burst mode operation of the half bridge converter driven by the primary controller.

## 5.7 EN and PROG pins: function and usage

The EN pin and PROG pin allow the user to configure two different operating modes:

- Automatic sleep mode function enabled (described in [Section 5.6](#))
- Automatic sleep mode function disabled

The configuration choice is done during the startup phase (when the supply voltage reaches the turn-on level  $V_{CC\_On}$ ) and internally stored as long as  $V_{CC}$  is within the supply range.

During the run mode the EN pin can be used as remote on-off input as well (both operating modes), using a small signal transistor connected to the pin as shown in [Figure 9](#): when the switch is closed, the pin voltage goes below the  $V_{EN\_OFF}$  threshold, the controller stops operating and enters a low consumption state; it resumes the operation when the switch is opened and the pin voltage surpasses the  $V_{EN\_ON}$  threshold. The small signal transistor has to be open during the startup phase.

Figure 9. EN - PROG pin configurations

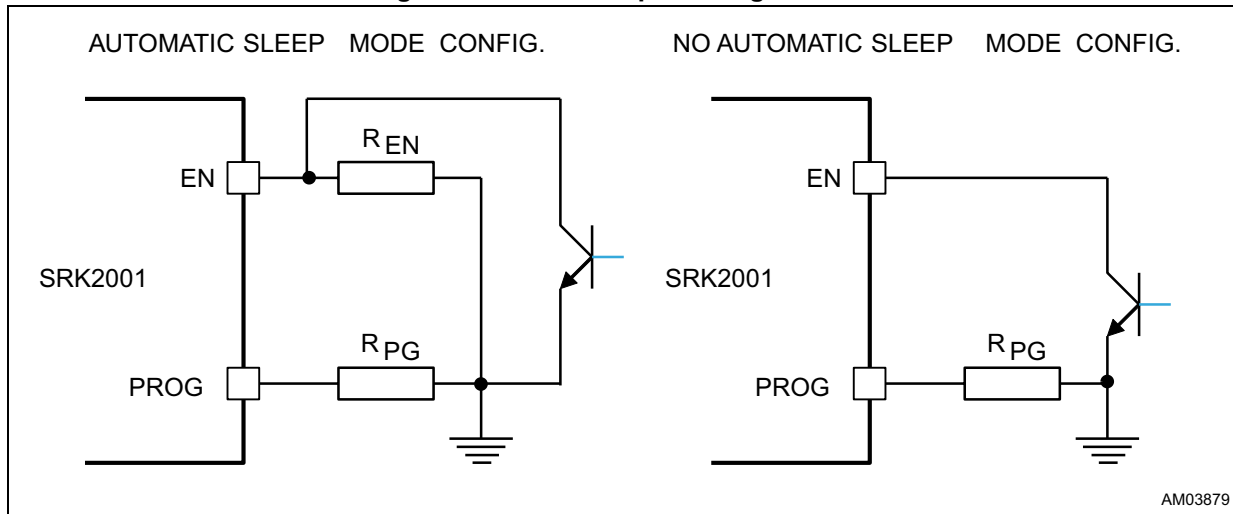

### 5.7.1 Automatic sleep mode function enabled

Only two resistors ( $R_{EN}$  -  $R_{PG}$ ) are used, connected from each of the two pins (EN-PROG) and GND (see [Figure 9](#)): during the startup phase, an internal current generator  $I_{EN}$  is enabled, the sourcing current to the EN pin that sets the voltage across the external resistor  $R_{EN}$ : by using a resistor value below or equal to 180 k $\Omega$ , the voltage across this resistor stays below an internal threshold and the controller enables automatic sleep mode function; this configuration is internally stored and, afterward, the current generator value is decreased to  $I_{EN\_run}$ .

At the same time, during the startup, a second current generator  $I_{PROG}$  sourcing the current to the PROG pin sets the voltage across the external resistor  $R_{PG}$ : depending on this voltage level, the sleep mode entering/exiting the conduction duty cycle is set, among those contained into the two internal lookup tables ([Table 6](#) and [Table 7](#)). After internal storing, the current generator  $I_{PROG}$  is disabled.

Either the lookup table is addressed depending on the value of the resistor  $R_{EN}$ . [Table 6](#) and [Table 7](#) show the allowed duty cycle combinations depending on  $R_{EN}$  and  $R_{PG}$  resistor values (1% tolerance).

Table 6. Lookup table I:  $R_{EN} = 100\text{ k}\Omega$

$D_{OFF}$	$D_{ON}$	$R_{PG}$
40%	80%	$R_{PG} = 0\ \Omega$
	75%	$R_{PG} = 100\text{ k}\Omega$
	65%	$R_{PG} = 180\text{ k}\Omega$
	60%	$R_{PG}$ open

**Table 7. Lookup table II:  $R_{EN} = 180\text{ k}\Omega$**

$D_{OFF}$	$D_{ON}$	$R_{PG}$
25%	75%	$R_{PG} = 0\text{ k}\Omega$
	70%	$R_{PG} = 100\ \Omega$
	60%	$R_{PG} = 180\text{ k}\Omega$
	55%	$R_{PG}$ open

### 5.7.2 Automatic sleep mode function disabled

The EN pin is open and only a resistor is connected to the PROG pin, as indicated in [Figure 9](#): at the startup (with the external switch open) an internal pull-up allows the EN pin voltage to increase above an internal threshold, where the automatic sleep mode function is disabled and the configuration is internally stored. In this way the controller does not enter the low consumption state when the conduction duty cycle reduces consequently to the light-load operation.

It is worth noticing that, with automatic sleep mode function disabled, the SR controller can still enter the low consumption mode, when it detects a half bridge converter stop (i.e.: primary controller burst mode operation) or when the EN pin is pulled down by the user (through a npn transistor like in [Figure 9](#)). After the primary side switching restarts or the EN pin goes back high, the controller resumes the operation when it detects that the conduction duty cycle has increased above the values in [Table 8](#): the user can select the desired value (internally stored during the startup phase) by a proper choice of the  $R_{PG}$  resistor.

**Table 8. Lookup table III:  $R_{EN} = \text{open}$**

$D_{ON\_BM}$	$R_{PG}$
80%	$R_{PG} = 0\ \Omega$
75%	$R_{PG} = 100\text{ k}\Omega$
65%	$R_{PG} = 180\text{ k}\Omega$
0%	$R_{PG}$ open

## 5.8 Layout guidelines

The GND pin is the return of the bias current of the device and the return for gate drive currents: it should be routed to the common point where the source terminals of both synchronous rectifier MOSFETs are connected. When laying out the PCB, care must be taken in keeping the source terminals of both SR MOSFETs as close to one another as possible and routing the trace that goes to GND separately from the load current return path. This trace should be as short as possible and be as close to the physical source terminals as possible. Doing the layout as more geometrically symmetrical as possible will help make the circuit operation as much electrically symmetrical as possible.

Also drain-source voltage sensing should be done as physically close to the drain and source terminals as possible in order to minimize the stray inductance involved by the load current path that is in the drain-to-source voltage sensing circuit.



The usage of bypass capacitors between  $V_{CC}$  and GND is recommended. They should be the low ESR, low ESL type and located as close to the IC pins as possible. Sometimes, a series resistor (in the tens  $\Omega$ ) between the converter's output voltage and the  $V_{CC}$  pin, forming an RC filter along with the bypass capacitor, is useful to get a cleaner  $V_{CC}$  voltage.

## 6 Package information

In order to meet environmental requirements, ST offers these devices in different grades of ECOPACK<sup>®</sup> packages, depending on their level of environmental compliance. ECOPACK specifications, grade definitions and product status are available at: [www.st.com](http://www.st.com). ECOPACK is an ST trademark.

# SSOP10 package information

Figure 10. SSOP10 package outline

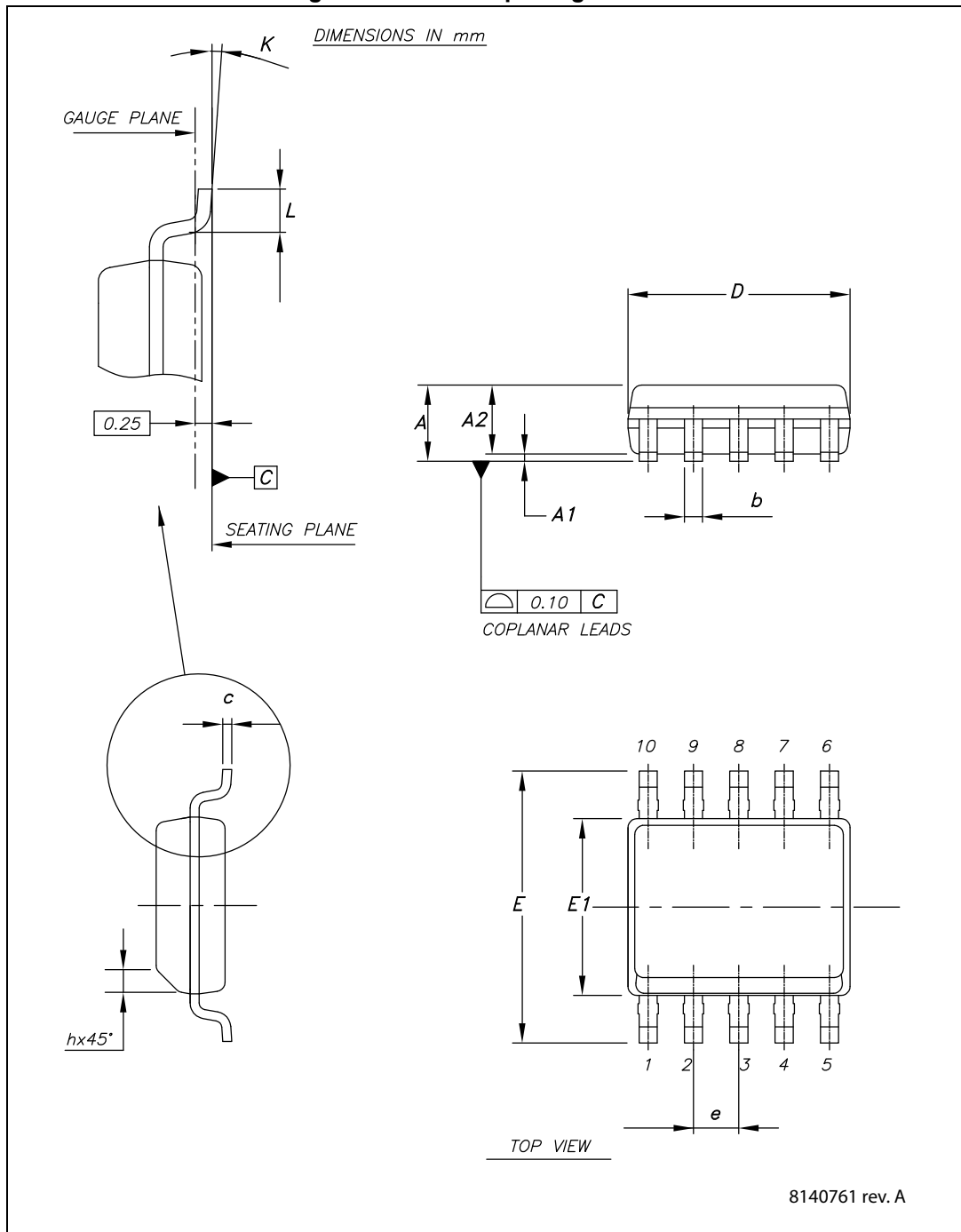

Table 9. SSOP10 package mechanical data

Symbol	Dimensions (mm)		
	Min.	Typ.	Max.
A			1.75
A1	0.10		0.25
A2	1.25		
b	0.31		0.51
c	0.17		0.25
D	4.80	4.90	5
E	5.80	6	6.20
E1	3.80	3.90	4
e		1	
h	0.25		0.50
L	0.40		0.90
K	0°		8°

## 7 Revision history

**Table 10. Document revision history**

Date	Revision	Changes
16-Jan-2015	1	Initial release.
09-Feb-2015	2	Updated <a href="#">Table 5 on page 7</a> (updated " $V_{GDclamp}$ " - SRK2001L/LTR - removed " $R_{GATE} = 5.6 \Omega$ ", removed min. and max. values).
12-May-2015	3	Updated <a href="#">Section 5.5 on page 13</a> . Minor modifications throughout document.

**IMPORTANT NOTICE – PLEASE READ CAREFULLY**

STMicroelectronics NV and its subsidiaries ("ST") reserve the right to make changes, corrections, enhancements, modifications, and improvements to ST products and/or to this document at any time without notice. Purchasers should obtain the latest relevant information on ST products before placing orders. ST products are sold pursuant to ST's terms and conditions of sale in place at the time of order acknowledgement.

Purchasers are solely responsible for the choice, selection, and use of ST products and ST assumes no liability for application assistance or the design of Purchasers' products.

No license, express or implied, to any intellectual property right is granted by ST herein.

Resale of ST products with provisions different from the information set forth herein shall void any warranty granted by ST for such product.

ST and the ST logo are trademarks of ST. All other product or service names are the property of their respective owners.

Information in this document supersedes and replaces information previously supplied in any prior versions of this document.

© 2015 STMicroelectronics – All rights reserved