

NOR GATES

- SP314A Single 7-Input
- SP317A Dual 4-Input Expandable
- SP370A Triple 3-Input
- SP380A Quad 2-Input

PIN CONFIGURATION

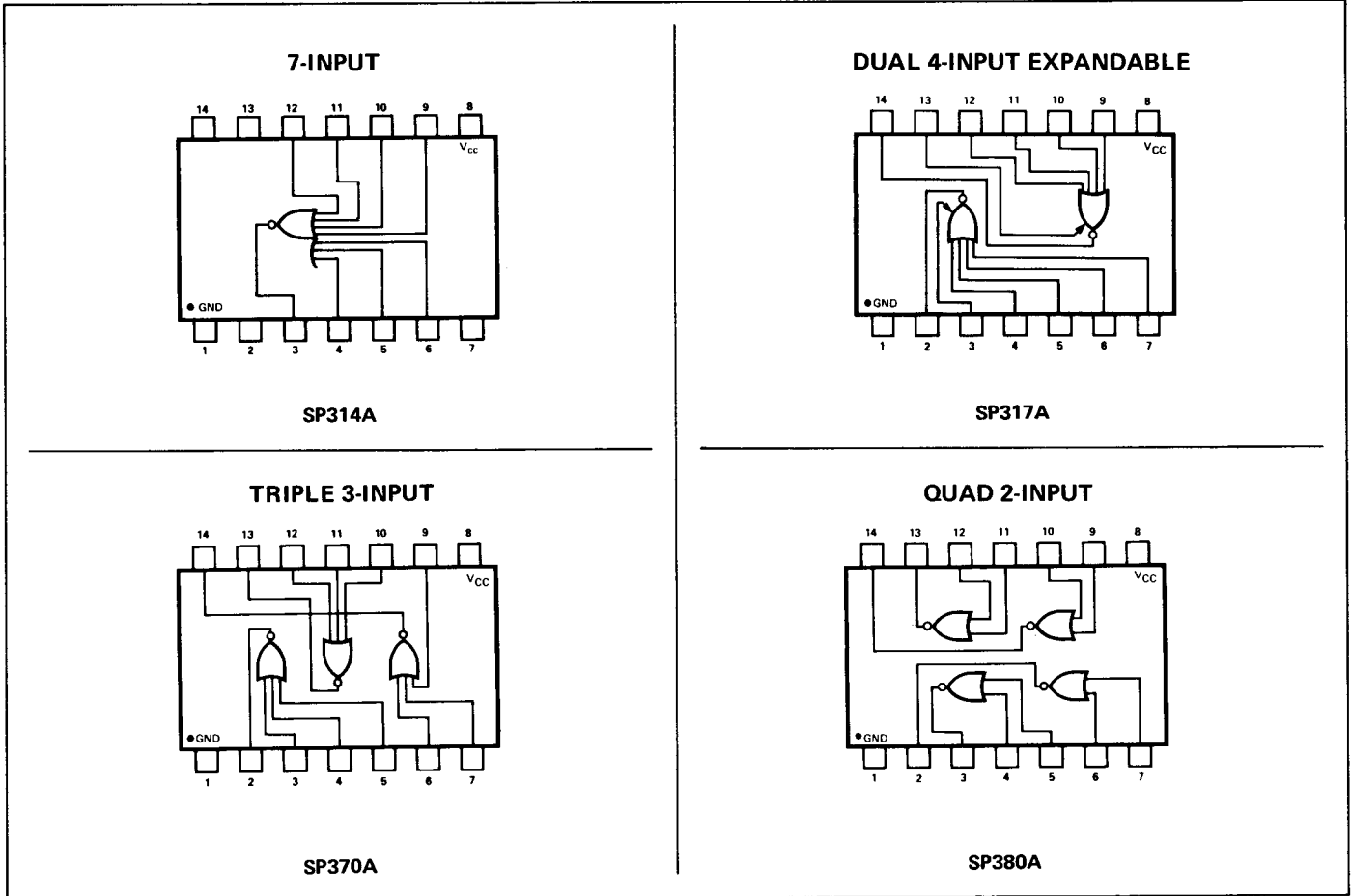

ELECTRICAL CHARACTERISTICS (Notes 1, 2, 3, 5 and 7)

Standard Conditions: $V_{CC} = 5.0V$, $T_A =$ Operating Temp. Range (Unless Noted)

CHARACTERISTIC	TEST CONDITIONS	MIN.	TYP	MAX.	UNITS
Noise Immunity for "1" for "0"	See Note 6	1100 600	1700 1000		mV mV
Output Voltage "1" Level "0" Level	$I_{out} = -2mA, V_{in} = 1.2V$ $I_{out} = 12.5mA, V_{in} = 2.7V$ $I_{out} = 7.5mA, V_{in} = 2.7V$	3.8		0.6 0.4	V V V
Input Current - input high	$V_{in} = 2.7V$			180	μA
Power Supply Current output high output low	$V_{in} = 0V, T_A = 25^\circ C$ $V_{in} = 4.0V, T_A = 25^\circ C$		13.4	0.3 18.1	mA/gate mA/gate
Turn on Delay	See Test Figure 1, $T_A = 25^\circ C$		25	60	ns
Turn off Delay	See Test Figure 1, $T_A = 25^\circ C$		50	80	ns
Fan-Out -To sink loads (2.5mA/load) -To source loads (180 μA /load)				5 11	
Expander Voltage (317 only)	$V_{in} = 2.7V$	1.85			V

Typical Values are for $T_A = 25^\circ C$. See Page 3 for Notes.

SCHEMATIC DIAGRAM

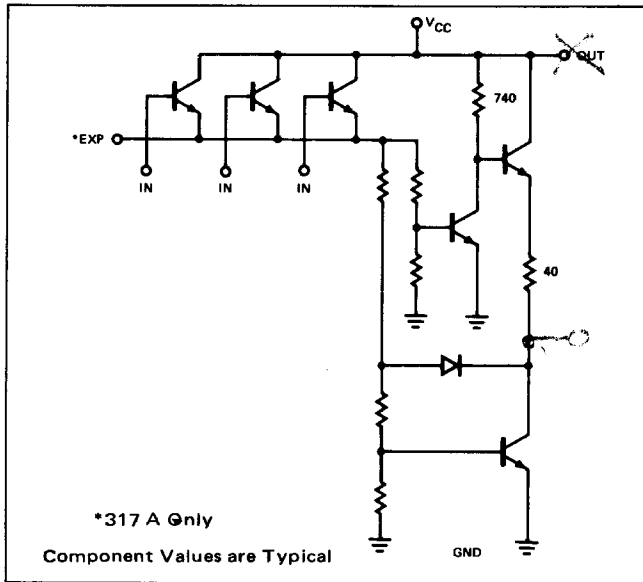

TEST CIRCUIT AND WAVEFORM

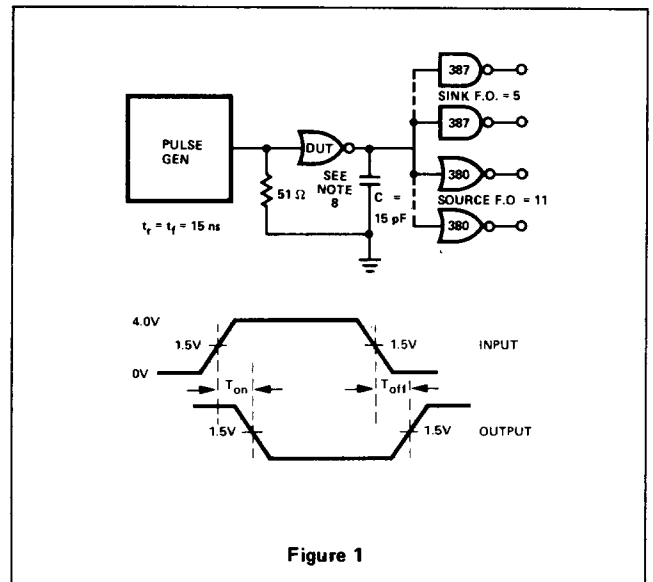

The following curves are normalized, when applicable, to the standard data sheet conditions.

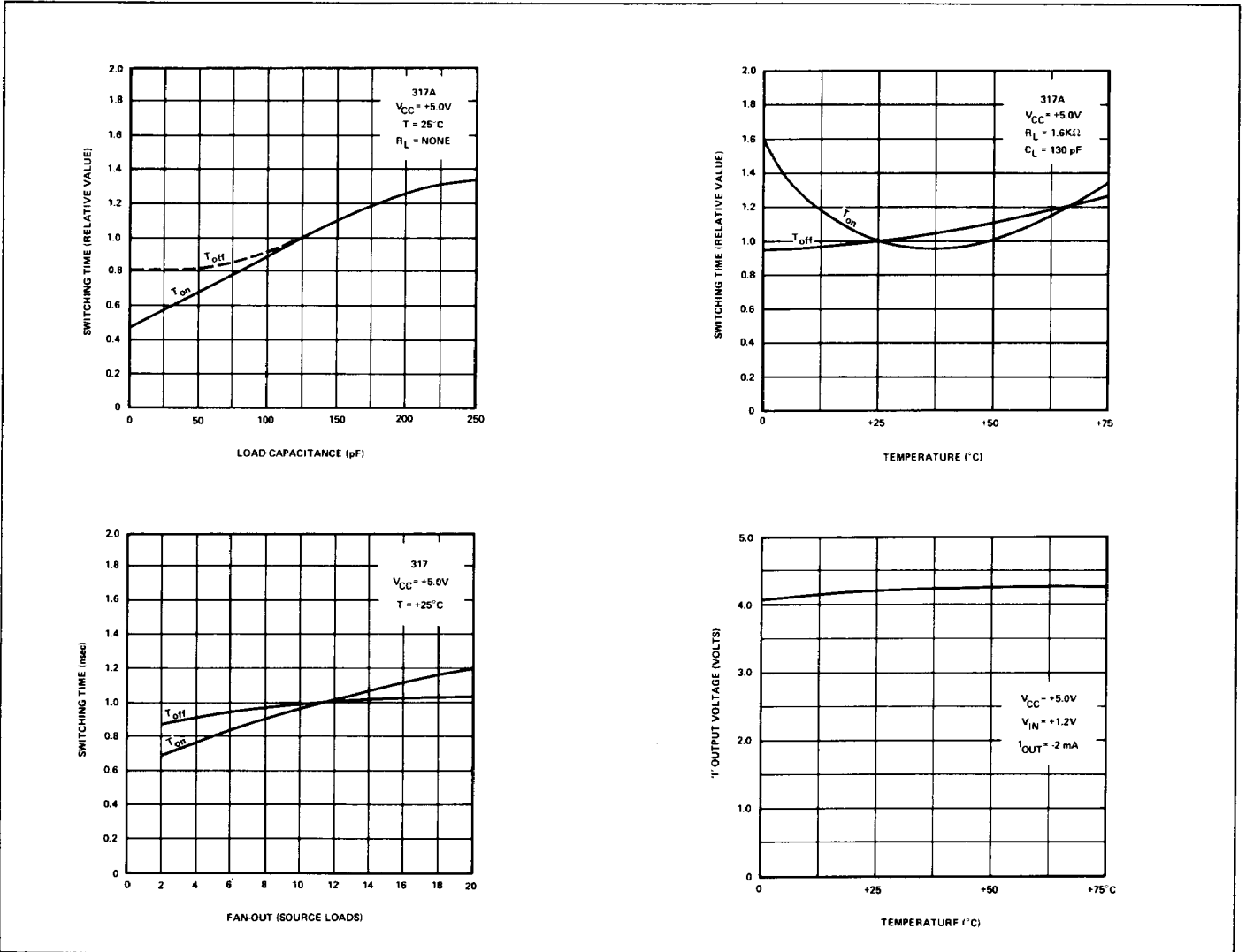

The following curves are normalized, when applicable, to the standard data sheet conditions.

