

## FlatLink™ RECEIVER

Check for Samples: [SN75LVDS82](#)

### FEATURES

- 4:28 Data Channel Expansion at up to 238 Mbytes/s Throughput
- Suited for SVGA, XGA, or SXGA Display Data Transmission From Controller to Display With Very Low EMI
- Four Data Channels and Clock Low-Voltage Differential Channels In and 28 Data and Clock Low-Voltage TTL Channels Out
- Operates From a Single 3.3-V Supply With 250 mW (Typ)
- 5-V Tolerant SHTDN Input
- Falling Clock-Edge-Triggered Outputs
- Packaged in Thin Shrink Small-Outline Package (TSSOP) With 20-Mil Terminal Pitch
- Consumes Less Than 1 mW When Disabled
- Wide Phase-Lock Input Frequency Range . . . 31 MHz to 68 MHz
- No External Components Required for PLL
- Inputs Meet or Exceed the Requirements of ANSI EIA/TIA-644 Standard
- Improved Replacement for the National™ DS90C582

### DESCRIPTION

The SN75LVDS82 FlatLink™ receiver contains four serial-in, 7-bit parallel-out shift registers, a 7× clock synthesizer, and five low-voltage differential signaling (LVDS) line receivers in a single integrated circuit.

These functions allow receipt of synchronous data from a compatible transmitter, such as the SN75LVDS81, over five balanced-pair conductors, and expansion to 28 bits of single-ended low-voltage TTL (LVTTTL) synchronous data at a lower transfer rate. The SN75LVDS82 can also be used with the SN75LVDS84 or SN75LVDS85 for 21-bit transfers.

When receiving, the high-speed LVDS data is received and loaded into registers at the rate of seven times (7×) the LVDS input clock (CLKIN). The data is then unloaded to a 28-bit-wide LVTTTL parallel bus at the CLKIN rate. A phase-locked loop (PLL) clock synthesizer circuit generates a 7× clock for internal clocking and an output clock for the expanded data. The SN75LVDS82 presents valid data on the falling edge of the output clock (CLKOUT).

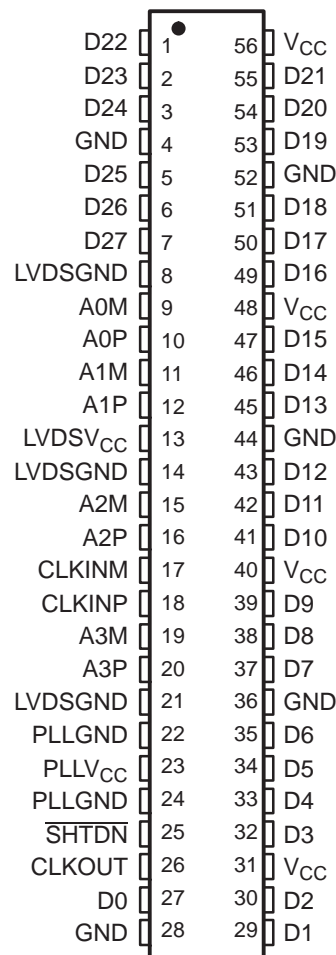
**DGG PACKAGE  
(TOP VIEW)**

Please be aware that an important notice concerning availability, standard warranty, and use in critical applications of Texas Instruments semiconductor products and disclaimers thereto appears at the end of this data sheet.

FlatLink is a trademark of Texas Instruments.

All other trademarks are the property of their respective owners.

The SN75LVDS82 requires only five line-termination resistors for the differential inputs and little or no control. The data bus appears the same at the input to the transmitter and output of the receiver with the data transmission transparent to the user. The only possible user intervention is the use of the shutdown/clear (SHTDN) active-low input to inhibit the clock and shut off the LVDS receivers for lower power consumption. A low-level on SHTDN clears all internal registers to a low level and places the CMOS outputs in a high-impedance state.

The SN75LVDS82 is characterized for operation over ambient air temperatures of 0°C to 70°C.

**FUNCTIONAL BLOCK DIAGRAM**

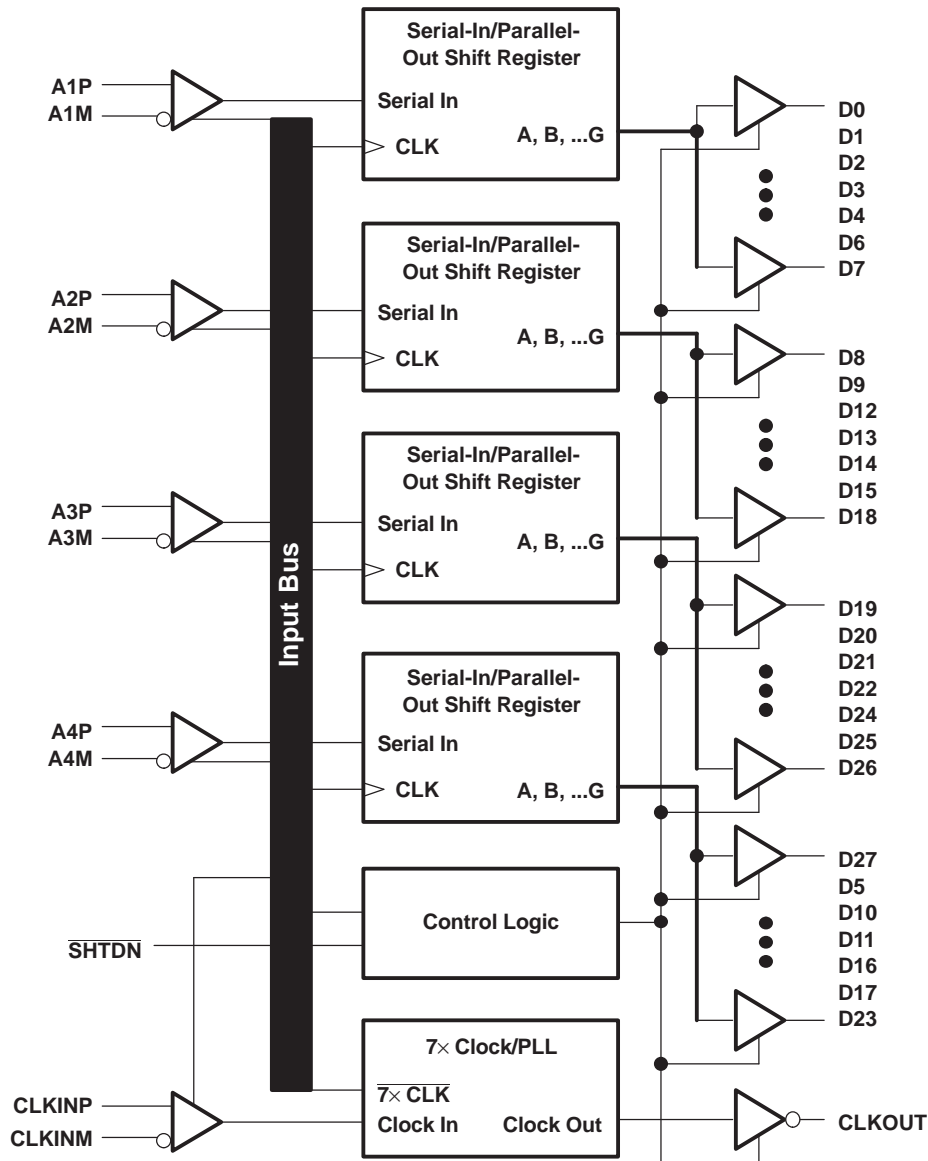

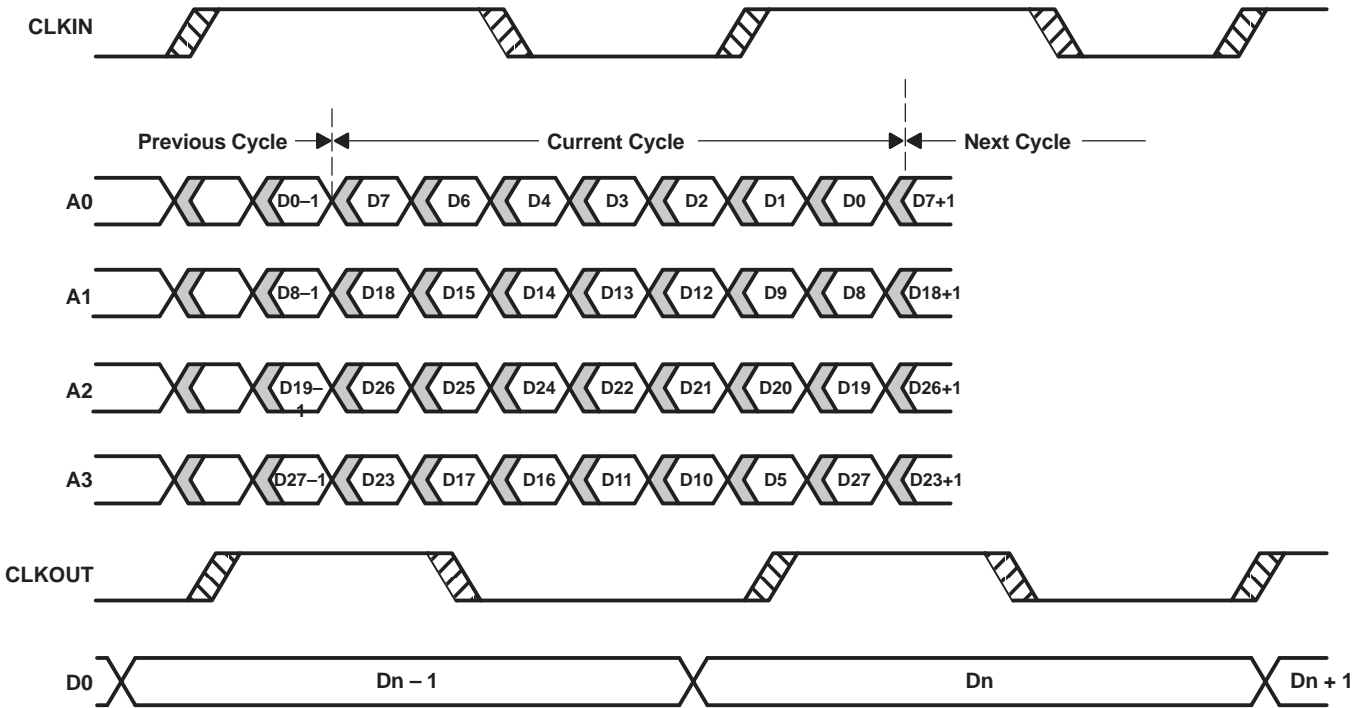
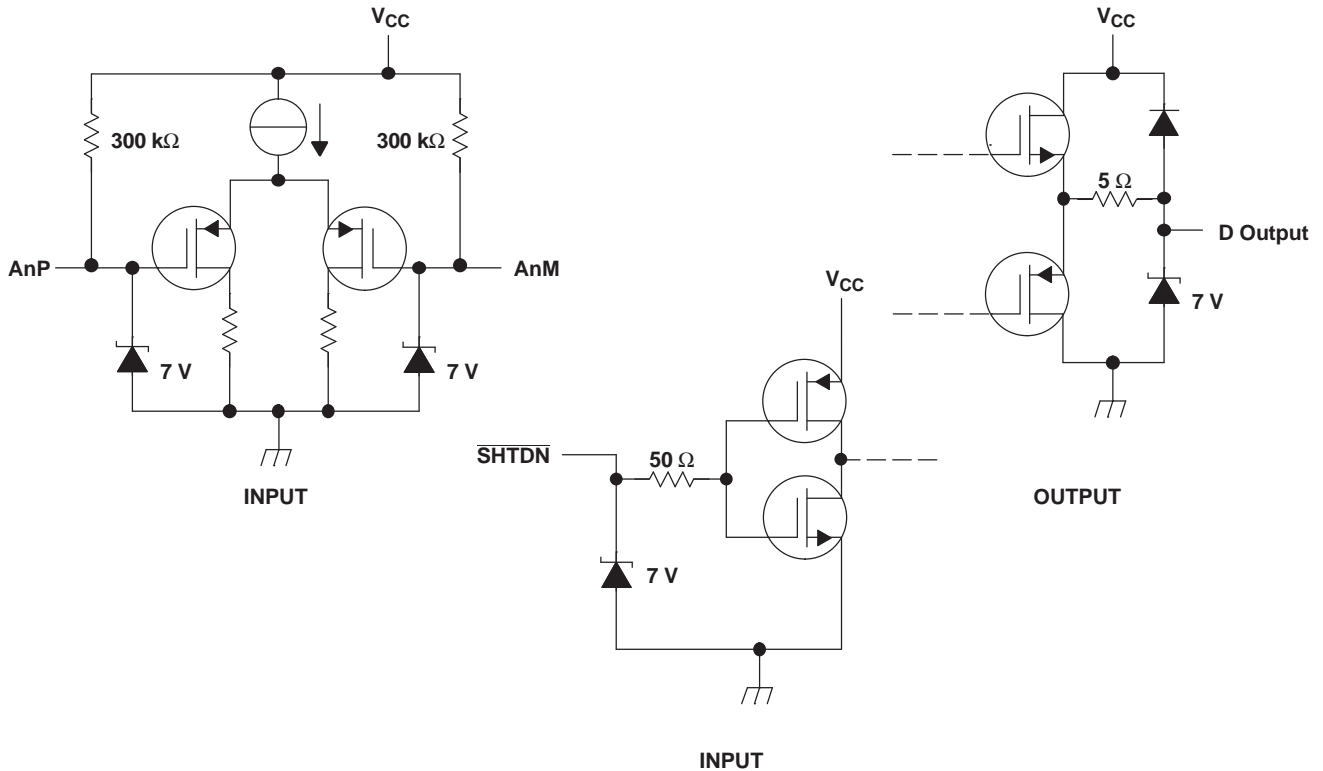

Figure 1. SN75LVDS82 Load and Shift Timing Sequences

EQUIVALENT INPUT AND OUTPUT SCHEMATIC DIAGRAMS



**ABSOLUTE MAXIMUM RATINGS<sup>(1)</sup>**

over operating free-air temperature range (unless otherwise noted)

		UNIT	
V <sub>CC</sub>	Supply voltage range <sup>(2)</sup>	–0.5 V to 4 V	
V <sub>O</sub>	Output voltage range (Dxx terminals)	–0.5 V to V <sub>CC</sub> + 0.5 V	
V <sub>I</sub>	Input voltage range	Any terminal except $\overline{\text{SHTDN}}$	–0.5 V to V <sub>CC</sub> + 0.5 V
		$\overline{\text{SHTDN}}$	–0.5 V to 5.5 V
Continuous total power dissipation		See Dissipation Rating Table	
T <sub>A</sub>	Operating temperature range	0°C to 70°C	
T <sub>stg</sub>	Storage temperature range	–65°C to 150°C	
Lead temperature 1,6 mm (1/16 in) from case for 10 s		260°C	

- (1) Stresses beyond those listed under "absolute maximum ratings" may cause permanent damage to the device. These are stress ratings only, and functional operation of the device at these or any other conditions beyond those indicated under "recommended operating conditions" is not implied. Exposure to absolute-maximum-rated conditions for extended periods may affect device reliability.
- (2) All voltage values are with respect to GND, unless otherwise noted.

**DISSIPATION RATING TABLE**

PACKAGE	T <sub>A</sub> ≤ 25°C POWER RATING	DERATING FACTOR <sup>(1)</sup> ABOVE T <sub>A</sub> = 25°C	T <sub>A</sub> = 70°C POWER RATING
DGG	1377 mW	11.0 mW/°C	822 mW

- (1) This is the inverse of the junction-to-ambient thermal resistance when board mounted and with no air flow.

**RECOMMENDED OPERATING CONDITIONS**

		MIN	NOM	MAX	UNIT
V <sub>CC</sub>	Supply voltage	3	3.3	3.6	V
V <sub>IH</sub>	High-level input voltage ( $\overline{\text{SHTDN}}$ )	2			V
V <sub>IL</sub>	Low-level input voltage ( $\overline{\text{SHTDN}}$ )			0.8	V
V <sub>ID</sub>	Differential input voltage	0.1		0.6	V
V <sub>IC</sub>	Common-mode input voltage (see <a href="#">Figure 2</a> and <a href="#">Figure 3</a> )			2.4 -	V
		$\frac{ V_{ID} }{2}$		$\frac{ V_{ID} }{2}$	
				V <sub>CC</sub> – 0.8	
T <sub>A</sub>	Operating free-air temperature	0		70	°C

**TIMING REQUIREMENTS**

		MIN	MAX	UNIT
t <sub>c</sub>	Cycle time, input clock <sup>(1)</sup>	14.7	32.3	ns
t <sub>su1</sub>	Setup time, input (see <a href="#">Figure 7</a> )	600		ps
t <sub>h1</sub>	Hold time, input (see <a href="#">Figure 7</a> )	600		ps

- (1) Parameter t<sub>c</sub> is defined as the mean duration of a minimum of 32000 clock cycles.

## ELECTRICAL CHARACTERISTICS

over recommended operating conditions (unless otherwise noted)

PARAMETER		TEST CONDITIONS	MIN	TYP <sup>(1)</sup>	MAX	UNIT
V <sub>IT+</sub>	Positive-going differential input threshold voltage				100	mV
V <sub>IT-</sub>	Negative-going differential input threshold voltage <sup>(2)</sup>		-100			mV
V <sub>OH</sub>	High-level output voltage	I <sub>OH</sub> = -4 mA	2.4			V
V <sub>OL</sub>	Low-level output voltage	I <sub>OL</sub> = 4 mA			0.4	V
I <sub>CC</sub>	Quiescent current (average)	Disabled, All inputs open			280	μA
		Enabled, AnP = 1 V, AnM = 1.4 V, t <sub>c</sub> = 15.38 ns		60	74	mA
		Enabled, C <sub>L</sub> = 8 pF, Grayscale pattern (see Figure 4), t <sub>c</sub> = 15.38 ns		74		
		Enabled, C <sub>L</sub> = 8 pF, Worst-case pattern (see Figure 5), t <sub>c</sub> = 15.38 ns		107		
I <sub>IH</sub>	High-level input current ( $\overline{\text{SHTDN}}$ )	V <sub>IH</sub> = V <sub>CC</sub>			±20	μA
I <sub>IL</sub>	Low-level input current ( $\overline{\text{SHTDN}}$ )	V <sub>IL</sub> = 0			±20	μA
I <sub>IN</sub>	Input current (LVDS input terminals A and CLKIN)	0 ≤ V <sub>I</sub> ≤ 2.4 V			±20	μA
I <sub>OZ</sub>	High-impedance output current	V <sub>O</sub> = 0 or V <sub>CC</sub>			±10	μA

(1) All typical values are at V<sub>CC</sub> = 3.3 V, T<sub>A</sub> = 25°C.

(2) The algebraic convention, in which the less-positive (more-negative) limit is designed minimum, is used in this data sheet for the negative-going input voltage threshold only.

## SWITCHING CHARACTERISTICS

over recommended operating conditions (unless otherwise noted)

PARAMETER		TEST CONDITIONS	MIN	TYP <sup>(1)</sup>	MAX	UNIT
t <sub>su2</sub>	Setup time, D0–D27 valid to CLKOUT↓	C <sub>L</sub> = 8 pF, See Figure 6	5			ns
t <sub>h2</sub>	Hold time, CLKOUT↓ to D0–D27 valid	C <sub>L</sub> = 8 pF, See Figure 6	5			ns
t <sub>RSKM</sub>	Receiver input skew margin <sup>(2)</sup> (see Figure 7)	t <sub>c</sub> = 15.38 ns (± 0.2%),  Input clock jitter  < 50 ps <sup>(3)</sup>	490			ps
t <sub>d</sub>	Delay time, CLKIN↑ to CLKOUT↓ (see Figure 7)	t <sub>c</sub> = 15.38 ns (± 0.2%), C <sub>L</sub> = 8 pF		3.7		ns
Δt <sub>c(o)</sub>	Cycle time, change in output clock period <sup>(4)</sup>	t <sub>c</sub> = 15.38 + 0.75 sin(2π500E3t) ± 0.05 ns, See Figure 8		±80		ps
		t <sub>c</sub> = 15.38 + 0.75 sin(2π3E6t) ± 0.05 ns, See Figure 8		±300		
t <sub>en</sub>	Enable time, $\overline{\text{SHTDN}}$ ↑ to Dn valid	See Figure 9		1		ms
t <sub>dis</sub>	Disable time, $\overline{\text{SHTDN}}$ ↓ to off state	See Figure 10		400		ns
t <sub>t</sub>	Transition time, output (10% to 90% t <sub>r</sub> or t <sub>f</sub> )	C <sub>L</sub> = 8 pF		3		ns
t <sub>w</sub>	Pulse duration, output clock			0.43 t <sub>c</sub>		ns

(1) All typical values are at V<sub>CC</sub> = 3.3 V, T<sub>A</sub> = 25°C.

(2) The parameter t<sub>RSKM</sub> is the timing margin available to the transmitter and interconnection skews and clock jitter. It is defined by t<sub>c</sub>/14 – t<sub>su1</sub>/t<sub>h1</sub>.

(3) |Input clock jitter| is the magnitude of the change in input clock period.

(4) Δt<sub>c(o)</sub> is the change in the output clock period from one cycle to the next cycle observed over 15000 cycles.

PARAMETER MEASUREMENT INFORMATION

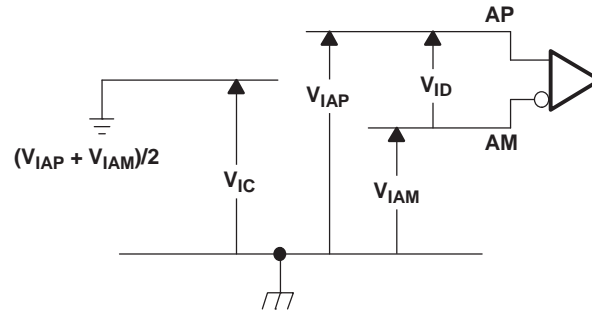

Figure 2. Voltage Definitions

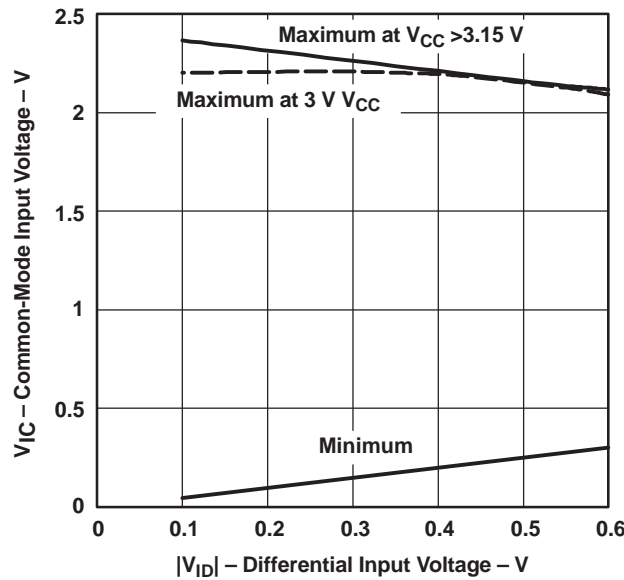
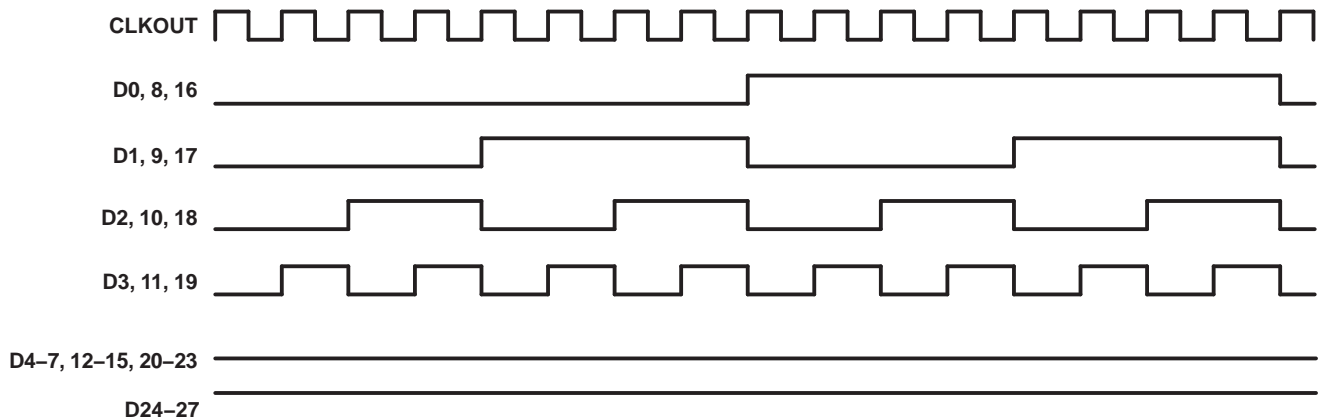

Figure 3. Common-Mode Input Voltage vs Differential Input Voltage



NOTE A: The 16-grayscale test-pattern tests device power consumption for a typical display pattern.

Figure 4. 16-Grayscale Test-Pattern Waveforms

PARAMETER MEASUREMENT INFORMATION (continued)

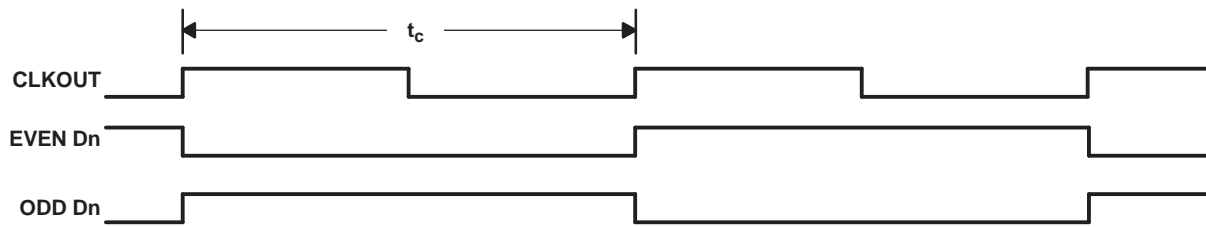

NOTE A: The worst-case test pattern produces the maximum switching frequency for all of the outputs.

Figure 5. Worst-Case Test-Pattern Waveforms

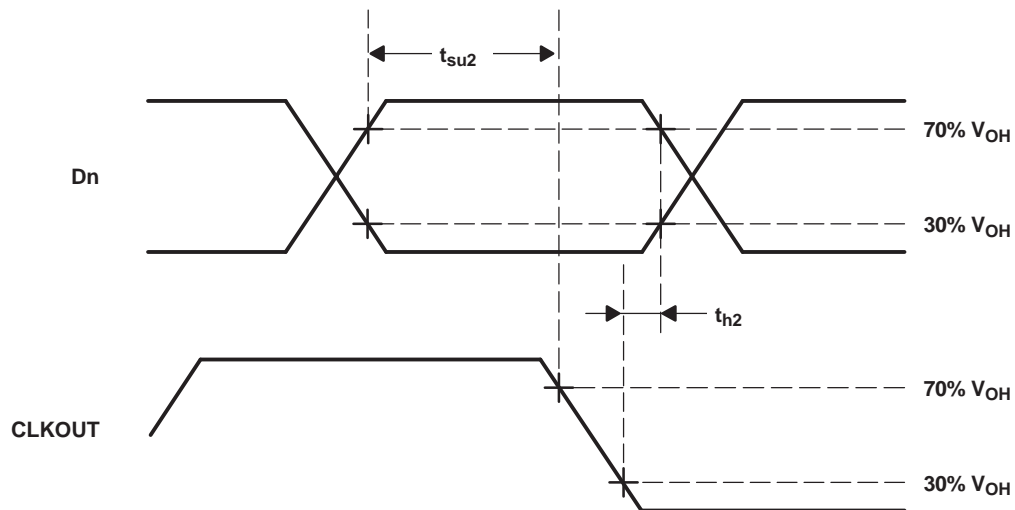
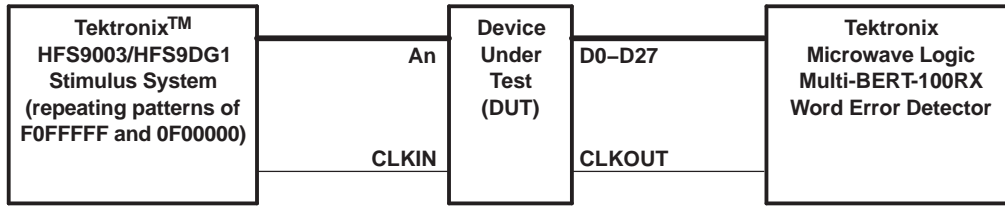
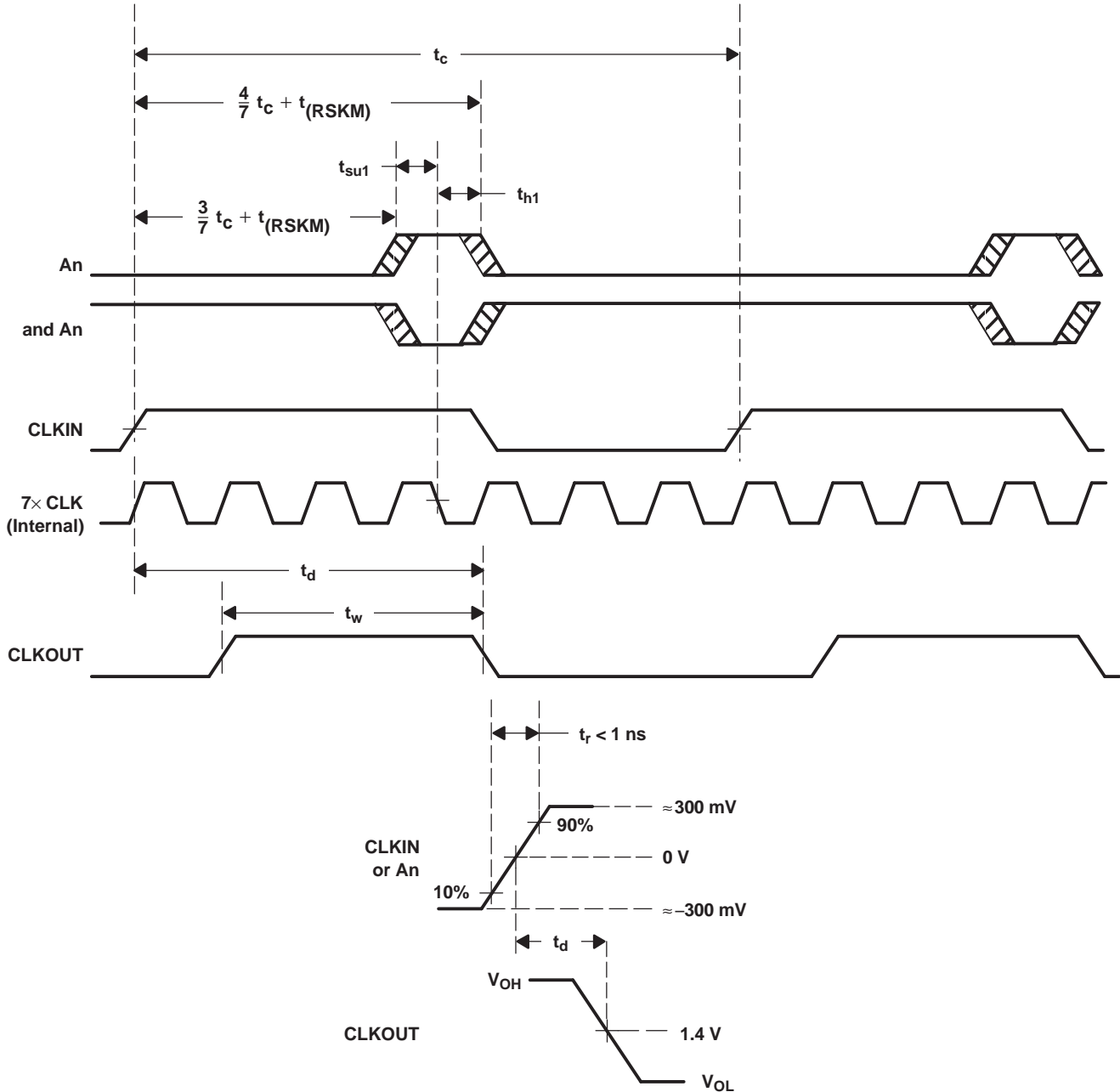

Figure 6. Setup and Hold Time Waveforms

**PARAMETER MEASUREMENT INFORMATION (continued)**



- A. CLKIN is advanced or delayed with respect to data until errors are observed at the receiver outputs. The magnitude of the advance or delay is  $t_{(RSKM)}$ .



**Figure 7. Receiver Input Skew Margin and Delay Timing Waveforms**



PARAMETER MEASUREMENT INFORMATION (continued)

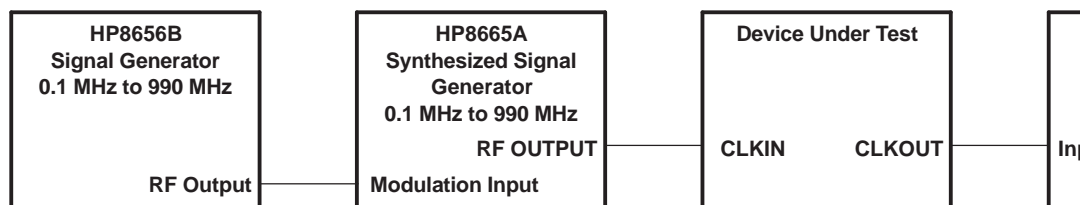
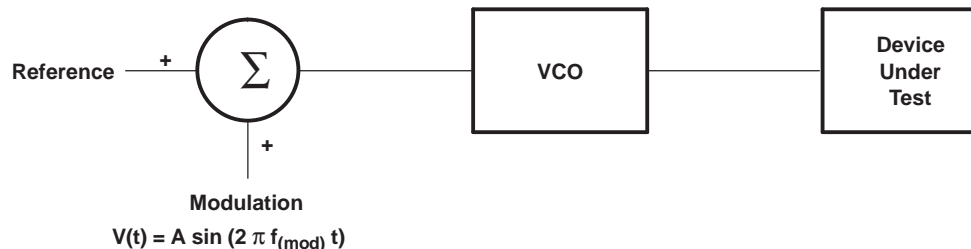

Figure 8. Input Clock Jitter Test

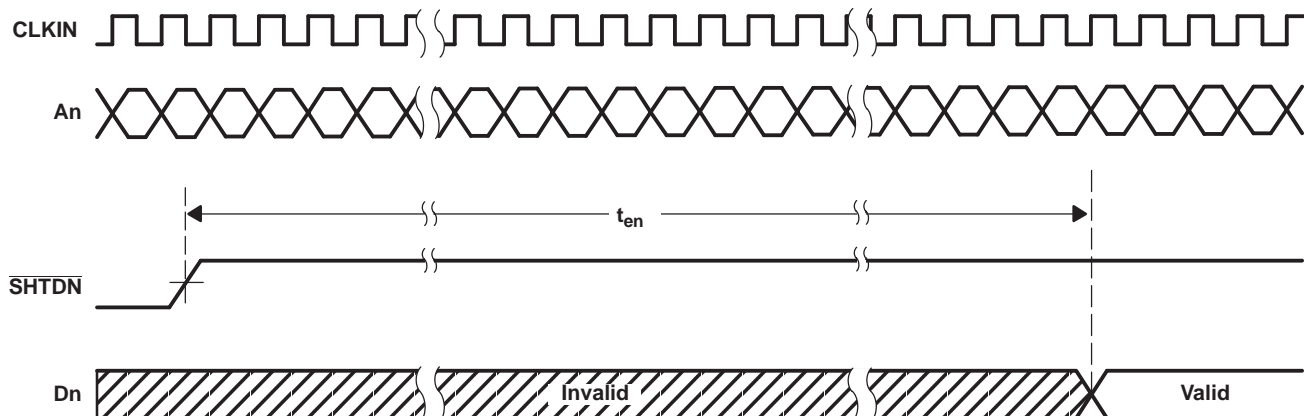

Figure 9. Enable Time Waveforms

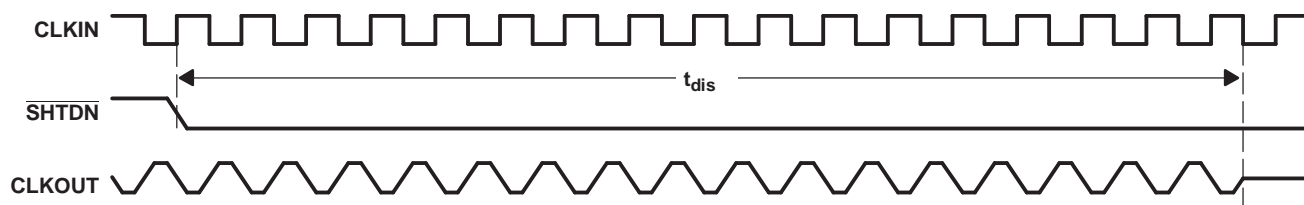

Figure 10. Disable Time Waveforms

TYPICAL CHARACTERISTICS

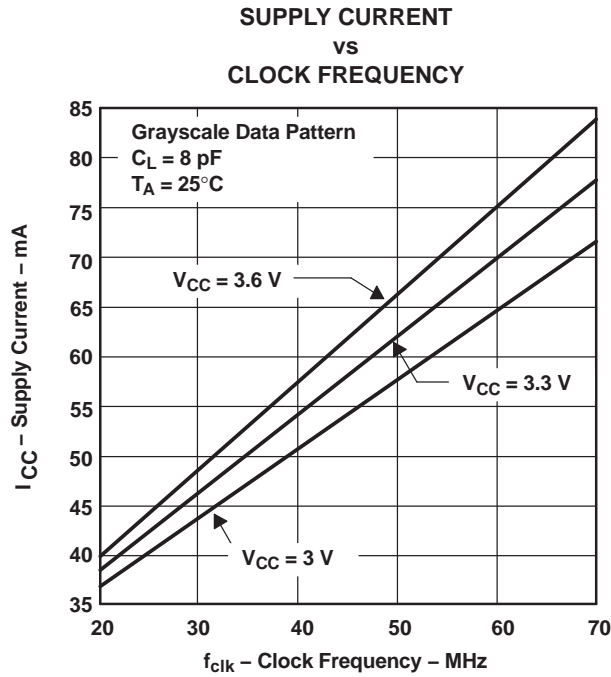

Figure 11.

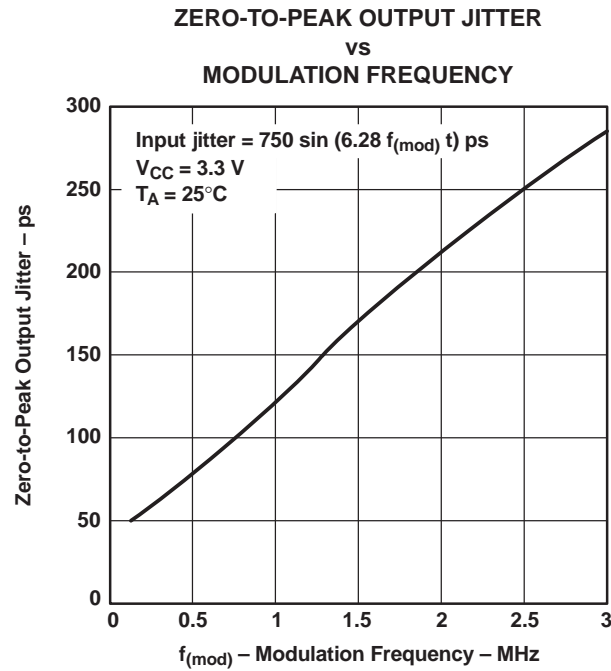
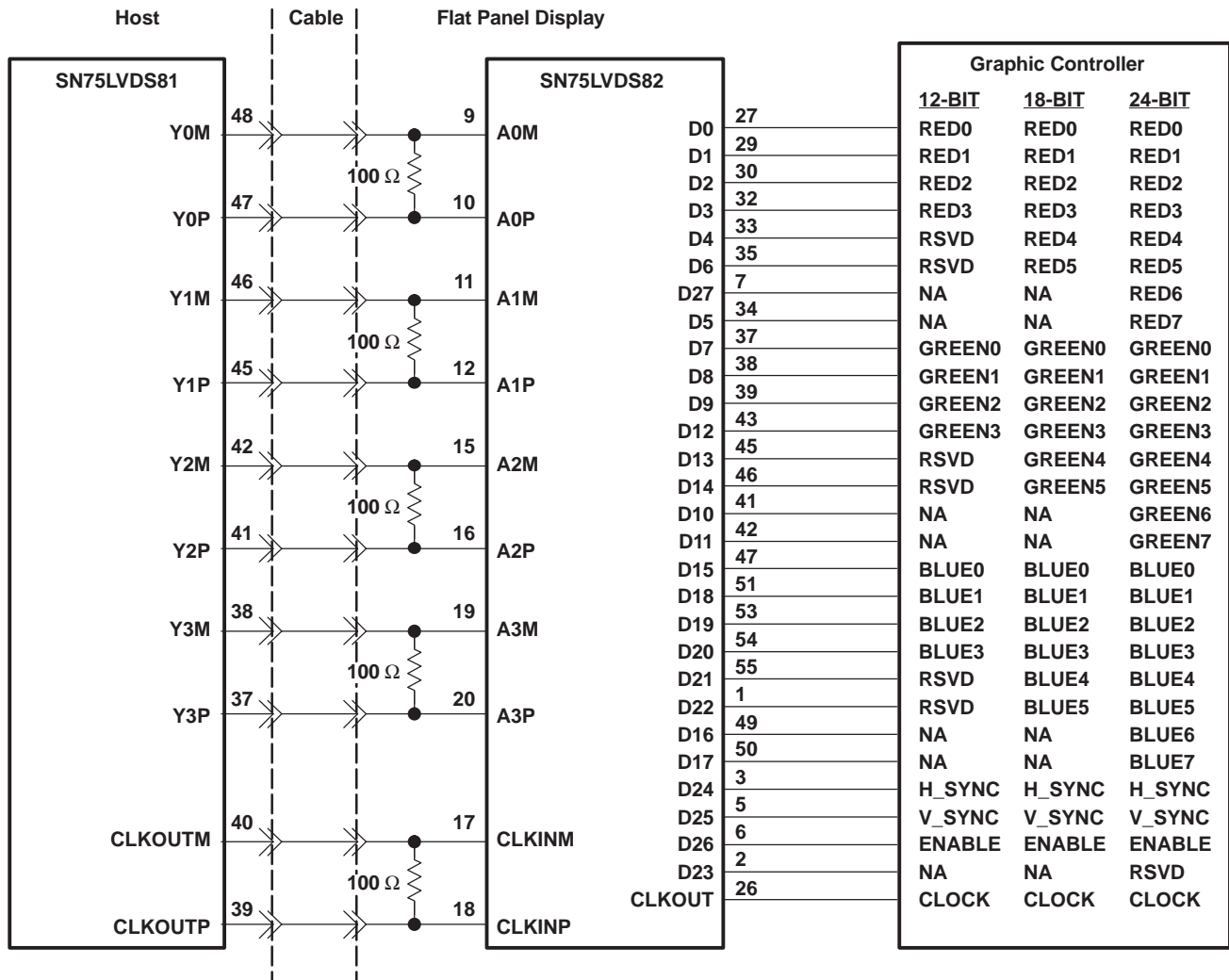

Figure 12.

APPLICATION INFORMATION



- A. The five 100-Ω terminating resistors are recommended to be 0603 types.
- B. NA — not applicable, these unused inputs should be left open.

Figure 13. 24-Bit Color Host to 24-Bit LCD Flat Panel Display Application

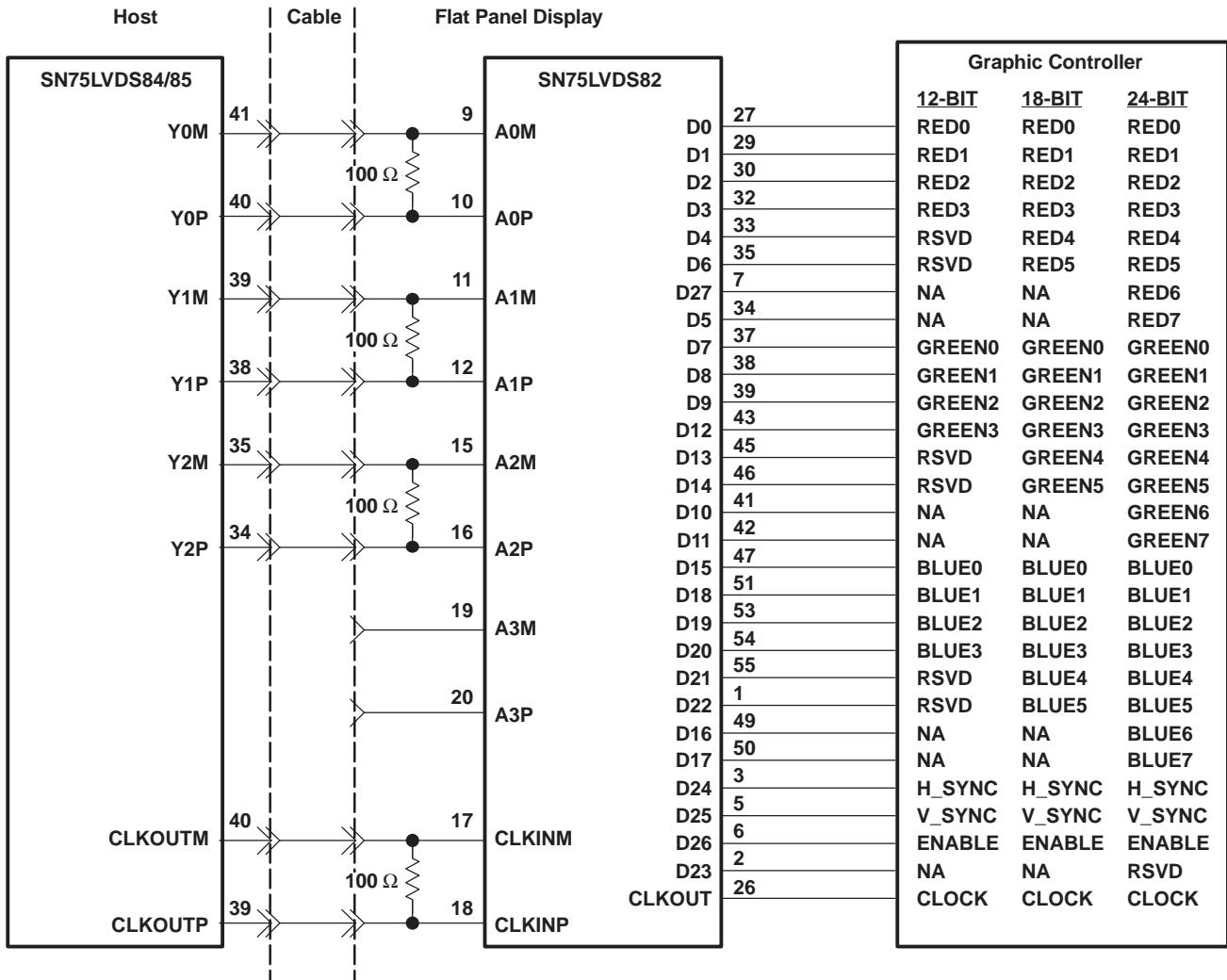

- A. The four 100-Ω terminating resistors are recommended to be 0603 types.
- B. NA — not applicable, these unused inputs should be left open.

**Figure 14. 18-Bit Color Host to 24-Bit Color LCD Panel Display Application**

**PACKAGING INFORMATION**

Orderable Device	Status (1)	Package Type	Package Drawing	Pins	Package Qty	Eco Plan (2)	Lead/Ball Finish	MSL Peak Temp (3)	Op Temp (°C)	Top-Side Markings (4)	Samples
SN75LVDS82DGG	ACTIVE	TSSOP	DGG	56	35	Green (RoHS & no Sb/Br)	CU NIPDAU	Level-2-260C-1 YEAR	0 to 70	SN75LVDS82	<a href="#">Samples</a>
SN75LVDS82DGGG4	ACTIVE	TSSOP	DGG	56	35	Green (RoHS & no Sb/Br)	CU NIPDAU	Level-2-260C-1 YEAR	0 to 70	SN75LVDS82	<a href="#">Samples</a>
SN75LVDS82DGGR	ACTIVE	TSSOP	DGG	56	2000	Green (RoHS & no Sb/Br)	CU NIPDAU	Level-2-260C-1 YEAR	0 to 70	SN75LVDS82	<a href="#">Samples</a>
SN75LVDS82DGGRG4	ACTIVE	TSSOP	DGG	56	2000	Green (RoHS & no Sb/Br)	CU NIPDAU	Level-2-260C-1 YEAR	0 to 70	SN75LVDS82	<a href="#">Samples</a>

(1) The marketing status values are defined as follows:

**ACTIVE:** Product device recommended for new designs.

**LIFEBUY:** TI has announced that the device will be discontinued, and a lifetime-buy period is in effect.

**NRND:** Not recommended for new designs. Device is in production to support existing customers, but TI does not recommend using this part in a new design.

**PREVIEW:** Device has been announced but is not in production. Samples may or may not be available.

**OBSOLETE:** TI has discontinued the production of the device.

(2) Eco Plan - The planned eco-friendly classification: Pb-Free (RoHS), Pb-Free (RoHS Exempt), or Green (RoHS & no Sb/Br) - please check <http://www.ti.com/productcontent> for the latest availability information and additional product content details.

**TBD:** The Pb-Free/Green conversion plan has not been defined.

**Pb-Free (RoHS):** TI's terms "Lead-Free" or "Pb-Free" mean semiconductor products that are compatible with the current RoHS requirements for all 6 substances, including the requirement that lead not exceed 0.1% by weight in homogeneous materials. Where designed to be soldered at high temperatures, TI Pb-Free products are suitable for use in specified lead-free processes.

**Pb-Free (RoHS Exempt):** This component has a RoHS exemption for either 1) lead-based flip-chip solder bumps used between the die and package, or 2) lead-based die adhesive used between the die and leadframe. The component is otherwise considered Pb-Free (RoHS compatible) as defined above.

**Green (RoHS & no Sb/Br):** TI defines "Green" to mean Pb-Free (RoHS compatible), and free of Bromine (Br) and Antimony (Sb) based flame retardants (Br or Sb do not exceed 0.1% by weight in homogeneous material)

(3) MSL, Peak Temp. -- The Moisture Sensitivity Level rating according to the JEDEC industry standard classifications, and peak solder temperature.

(4) Multiple Top-Side Markings will be inside parentheses. Only one Top-Side Marking contained in parentheses and separated by a "~" will appear on a device. If a line is indented then it is a continuation of the previous line and the two combined represent the entire Top-Side Marking for that device.

**Important Information and Disclaimer:** The information provided on this page represents TI's knowledge and belief as of the date that it is provided. TI bases its knowledge and belief on information provided by third parties, and makes no representation or warranty as to the accuracy of such information. Efforts are underway to better integrate information from third parties. TI has taken and continues to take reasonable steps to provide representative and accurate information but may not have conducted destructive testing or chemical analysis on incoming materials and chemicals. TI and TI suppliers consider certain information to be proprietary, and thus CAS numbers and other limited information may not be available for release.

In no event shall TI's liability arising out of such information exceed the total purchase price of the TI part(s) at issue in this document sold by TI to Customer on an annual basis.



## TAPE AND REEL INFORMATION



### QUADRANT ASSIGNMENTS FOR PIN 1 ORIENTATION IN TAPE



\*All dimensions are nominal

Device	Package Type	Package Drawing	Pins	SPQ	Reel Diameter (mm)	Reel Width W1 (mm)	A0 (mm)	B0 (mm)	K0 (mm)	P1 (mm)	W (mm)	Pin1 Quadrant
SN75LVDS82DGGR	TSSOP	DGG	56	2000	330.0	24.4	8.6	15.6	1.8	12.0	24.0	Q1

**TAPE AND REEL BOX DIMENSIONS**



\*All dimensions are nominal

Device	Package Type	Package Drawing	Pins	SPQ	Length (mm)	Width (mm)	Height (mm)
SN75LVDS82DGGR	TSSOP	DGG	56	2000	367.0	367.0	45.0



# DGG0056A



# PACKAGE OUTLINE

## TSSOP - 1.2 mm max height

SMALL OUTLINE PACKAGE

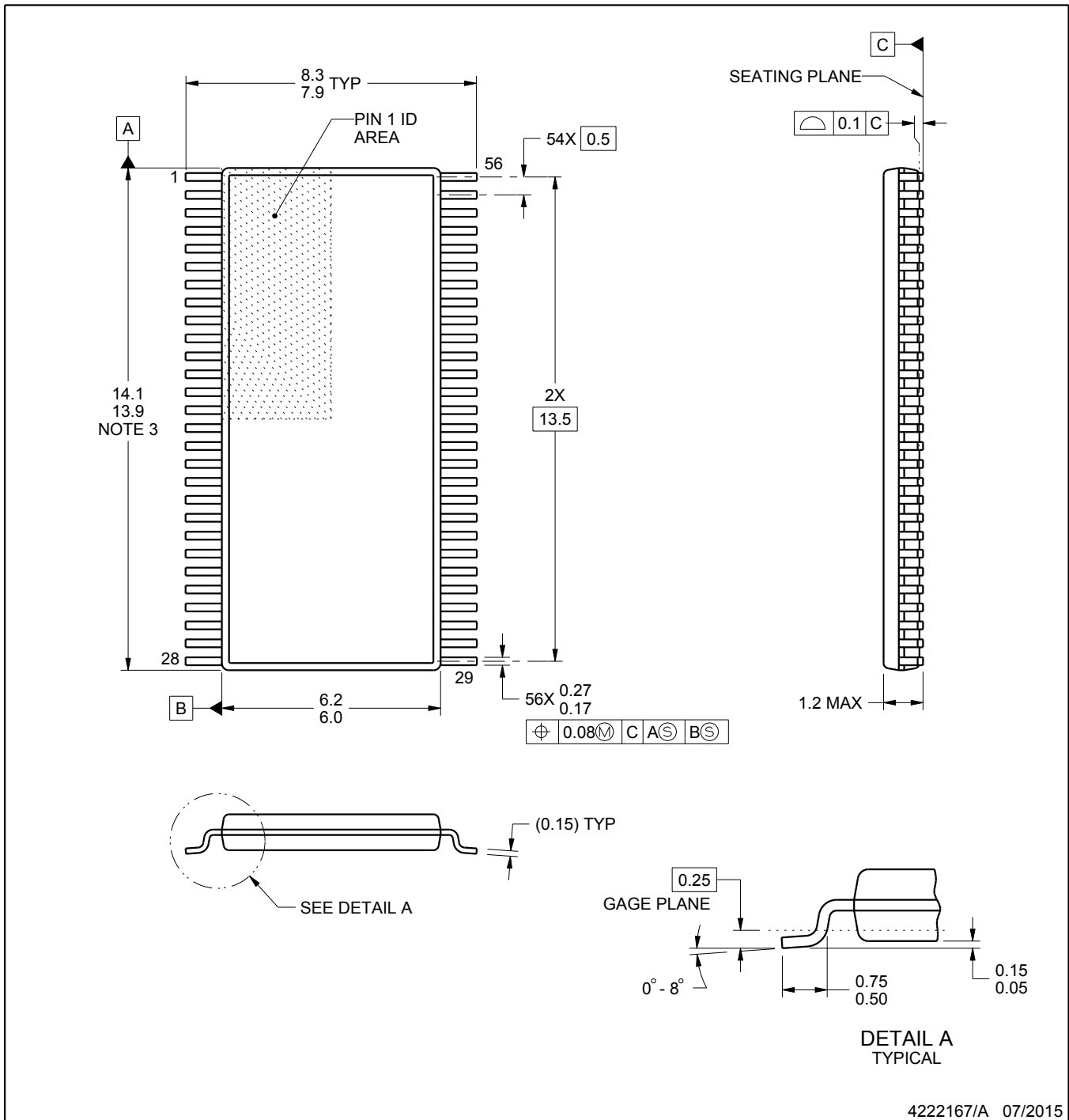

4222167/A 07/2015

### NOTES:

- All linear dimensions are in millimeters. Any dimensions in parenthesis are for reference only. Dimensioning and tolerancing per ASME Y14.5M.
- This drawing is subject to change without notice.
- This dimension does not include mold flash, protrusions, or gate burrs. Mold flash, protrusions, or gate burrs shall not exceed 0.15 mm per side.
- Reference JEDEC registration MO-153.

# EXAMPLE BOARD LAYOUT

DGG0056A

TSSOP - 1.2 mm max height

SMALL OUTLINE PACKAGE



LAND PATTERN EXAMPLE  
SCALE:6X

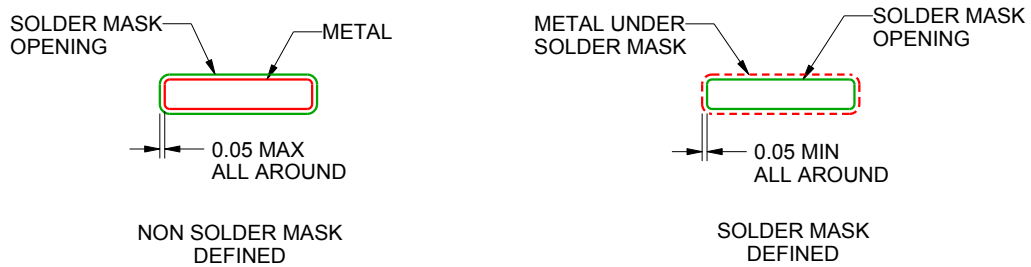

SOLDER MASK DETAILS

4222167/A 07/2015

NOTES: (continued)

- 5. Publication IPC-7351 may have alternate designs.
- 6. Solder mask tolerances between and around signal pads can vary based on board fabrication site.

# EXAMPLE STENCIL DESIGN

DGG0056A

TSSOP - 1.2 mm max height

SMALL OUTLINE PACKAGE



SOLDER PASTE EXAMPLE  
BASED ON 0.125 mm THICK STENCIL  
SCALE:6X

4222167/A 07/2015

NOTES: (continued)

7. Laser cutting apertures with trapezoidal walls and rounded corners may offer better paste release. IPC-7525 may have alternate design recommendations.
8. Board assembly site may have different recommendations for stencil design.

## IMPORTANT NOTICE

Texas Instruments Incorporated and its subsidiaries (TI) reserve the right to make corrections, enhancements, improvements and other changes to its semiconductor products and services per JESD46, latest issue, and to discontinue any product or service per JESD48, latest issue. Buyers should obtain the latest relevant information before placing orders and should verify that such information is current and complete. All semiconductor products (also referred to herein as "components") are sold subject to TI's terms and conditions of sale supplied at the time of order acknowledgment.

TI warrants performance of its components to the specifications applicable at the time of sale, in accordance with the warranty in TI's terms and conditions of sale of semiconductor products. Testing and other quality control techniques are used to the extent TI deems necessary to support this warranty. Except where mandated by applicable law, testing of all parameters of each component is not necessarily performed.

TI assumes no liability for applications assistance or the design of Buyers' products. Buyers are responsible for their products and applications using TI components. To minimize the risks associated with Buyers' products and applications, Buyers should provide adequate design and operating safeguards.

TI does not warrant or represent that any license, either express or implied, is granted under any patent right, copyright, mask work right, or other intellectual property right relating to any combination, machine, or process in which TI components or services are used. Information published by TI regarding third-party products or services does not constitute a license to use such products or services or a warranty or endorsement thereof. Use of such information may require a license from a third party under the patents or other intellectual property of the third party, or a license from TI under the patents or other intellectual property of TI.

Reproduction of significant portions of TI information in TI data books or data sheets is permissible only if reproduction is without alteration and is accompanied by all associated warranties, conditions, limitations, and notices. TI is not responsible or liable for such altered documentation. Information of third parties may be subject to additional restrictions.

Resale of TI components or services with statements different from or beyond the parameters stated by TI for that component or service voids all express and any implied warranties for the associated TI component or service and is an unfair and deceptive business practice. TI is not responsible or liable for any such statements.

Buyer acknowledges and agrees that it is solely responsible for compliance with all legal, regulatory and safety-related requirements concerning its products, and any use of TI components in its applications, notwithstanding any applications-related information or support that may be provided by TI. Buyer represents and agrees that it has all the necessary expertise to create and implement safeguards which anticipate dangerous consequences of failures, monitor failures and their consequences, lessen the likelihood of failures that might cause harm and take appropriate remedial actions. Buyer will fully indemnify TI and its representatives against any damages arising out of the use of any TI components in safety-critical applications.

In some cases, TI components may be promoted specifically to facilitate safety-related applications. With such components, TI's goal is to help enable customers to design and create their own end-product solutions that meet applicable functional safety standards and requirements. Nonetheless, such components are subject to these terms.

No TI components are authorized for use in FDA Class III (or similar life-critical medical equipment) unless authorized officers of the parties have executed a special agreement specifically governing such use.

Only those TI components which TI has specifically designated as military grade or "enhanced plastic" are designed and intended for use in military/aerospace applications or environments. Buyer acknowledges and agrees that any military or aerospace use of TI components which have **not** been so designated is solely at the Buyer's risk, and that Buyer is solely responsible for compliance with all legal and regulatory requirements in connection with such use.

TI has specifically designated certain components as meeting ISO/TS16949 requirements, mainly for automotive use. In any case of use of non-designated products, TI will not be responsible for any failure to meet ISO/TS16949.

### Products

Audio	<a href="http://www.ti.com/audio">www.ti.com/audio</a>
Amplifiers	<a href="http://amplifier.ti.com">amplifier.ti.com</a>
Data Converters	<a href="http://dataconverter.ti.com">dataconverter.ti.com</a>
DLP® Products	<a href="http://www.dlp.com">www.dlp.com</a>
DSP	<a href="http://dsp.ti.com">dsp.ti.com</a>
Clocks and Timers	<a href="http://www.ti.com/clocks">www.ti.com/clocks</a>
Interface	<a href="http://interface.ti.com">interface.ti.com</a>
Logic	<a href="http://logic.ti.com">logic.ti.com</a>
Power Mgmt	<a href="http://power.ti.com">power.ti.com</a>
Microcontrollers	<a href="http://microcontroller.ti.com">microcontroller.ti.com</a>
RFID	<a href="http://www.ti-rfid.com">www.ti-rfid.com</a>
OMAP Applications Processors	<a href="http://www.ti.com/omap">www.ti.com/omap</a>
Wireless Connectivity	<a href="http://www.ti.com/wirelessconnectivity">www.ti.com/wirelessconnectivity</a>

### Applications

Automotive and Transportation	<a href="http://www.ti.com/automotive">www.ti.com/automotive</a>
Communications and Telecom	<a href="http://www.ti.com/communications">www.ti.com/communications</a>
Computers and Peripherals	<a href="http://www.ti.com/computers">www.ti.com/computers</a>
Consumer Electronics	<a href="http://www.ti.com/consumer-apps">www.ti.com/consumer-apps</a>
Energy and Lighting	<a href="http://www.ti.com/energy">www.ti.com/energy</a>
Industrial	<a href="http://www.ti.com/industrial">www.ti.com/industrial</a>
Medical	<a href="http://www.ti.com/medical">www.ti.com/medical</a>
Security	<a href="http://www.ti.com/security">www.ti.com/security</a>
Space, Avionics and Defense	<a href="http://www.ti.com/space-avionics-defense">www.ti.com/space-avionics-defense</a>
Video and Imaging	<a href="http://www.ti.com/video">www.ti.com/video</a>

### TI E2E Community

[e2e.ti.com](http://e2e.ti.com)