

# SN75ALS171, SN75ALS171A TRIPLE DIFFERENTIAL BUS TRANSCEIVERS

SLLS056D – AUGUST 1987 – REVISED SEPTEMBER 1995

- Three Bidirectional Transceivers
- Driver Meets or Exceeds the Requirements of ANSI EIA/TIA-422-B and RS-485 and ITU Recommendation V.11
- Two Skew Limits Available
- Designed to Operate Up to 20 Million Data Transfers per Second (FAST-20 SCSI)
- High-Speed Advanced Low-Power Schottky Circuitry
- Low Pulse Skew . . . 5 ns Max
- Designed for Multipoint Transmission on Long Bus Lines in Noisy Environments
- Features Independent Driver Enables and Combined Receiver Enables
- Wide Positive and Negative Input/Output Bus Voltages Ranges
- Driver Output Capacity . . .  $\pm 60$  mA
- Thermal Shutdown Protection
- Driver Positive- and Negative-Current Limiting
- Receiver Input Impedances . . . 12 k $\Omega$  Min
- Receiver Input Sensitivity . . .  $\pm 300$  mV Max
- Receiver Input Hysteresis . . . 60 mV Typ
- Operates From a Single 5-V Supply
- Glitch-Free Power-Up and Power-Down Protection

DW OR J PACKAGE  
(TOP VIEW)

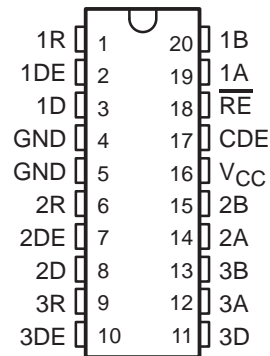

## description

The SN75ALS171 and the SN75ALS171A triple differential bus transceivers are monolithic integrated circuits designed for bidirectional data communication on multipoint bus transmission lines. They are designed for balanced transmission lines, and each driver meets ANSI Standards EIA/TIA-422-B and RS-485 and both the drivers and receivers meet ITU Recommendation V.11. The SN75ALS171A is designed for FAST-20 SCSI and can transmit or receive data pulses as short as 30 ns with a maximum skew of 5 ns.

The SN75ALS171 and the SN75ALS171A operate from a single 5-V power supply. The drivers and receivers have individual active-high and active-low enables, respectively, which can be externally connected together to function as a direction control. The driver differential output and the receiver differential input pairs are connected internally to form differential input/output (I/O) bus ports that are designed to offer minimum loading to the bus when the driver is disabled or V<sub>CC</sub> is at 0 V. These ports feature wide positive and negative common-mode voltage ranges making the device suitable for party-line applications.

The SN75ALS171 and the SN75ALS171A are characterized for operation from 0°C to 70°C.



Please be aware that an important notice concerning availability, standard warranty, and use in critical applications of Texas Instruments semiconductor products and disclaimers thereto appears at the end of this data sheet.

PRODUCTION DATA information is current as of publication date. Products conform to specifications per the terms of Texas Instruments standard warranty. Production processing does not necessarily include testing of all parameters.

 **TEXAS  
INSTRUMENTS**

POST OFFICE BOX 655303 • DALLAS, TEXAS 75265

Copyright © 1995, Texas Instruments Incorporated

# SN75ALS171, SN75ALS171A TRIPLE DIFFERENTIAL BUS TRANSCEIVERS

SLLS056D – AUGUST 1987 – REVISED SEPTEMBER 1995

## Function Tables

### EACH DRIVER

INPUT D	ENABLES		OUTPUTS	
	DE	CDE	A	B
H	H	H	H	L
L	H	H	L	H
X	L	X	Z	Z
X	X	L	Z	Z

### EACH RECEIVER

DIFFERENTIAL INPUTS A-B	ENABLE $\overline{RE}$	OUTPUT R
$V_{ID} \geq 0.3\text{ V}$	L	H
$-0.3\text{ V} < V_{ID} < 0.3\text{ V}$	L	?
$V_{ID} \leq -0.3\text{ V}$	L	L
X	H	Z
Open	L	H

H = high level, L = low level, ? = indeterminate, X = irrelevant,  
Z = high impedance (off)

### AVAILABLE OPTIONS

SKEW LIMIT	PART NUMBER	
	10 ns	SN75ALS171DW
5 ns	SN75ALS171ADW	

# SN75ALS171, SN75ALS171A TRIPLE DIFFERENTIAL BUS TRANSCEIVERS

SLLS056D – AUGUST 1987 – REVISED SEPTEMBER 1995

## logic symbol†

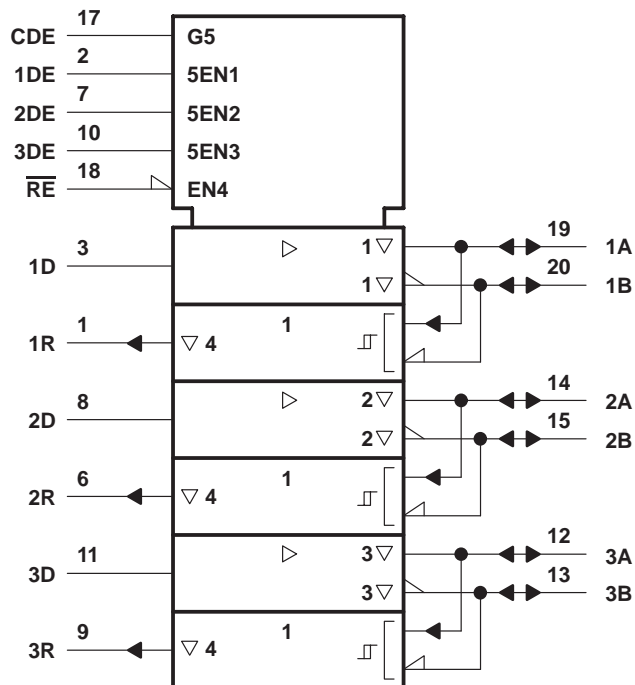

† This symbol is in accordance with ANSI/IEEE Std 91-1984 and IEC Publication 617-12.

## logic diagram (positive logic)

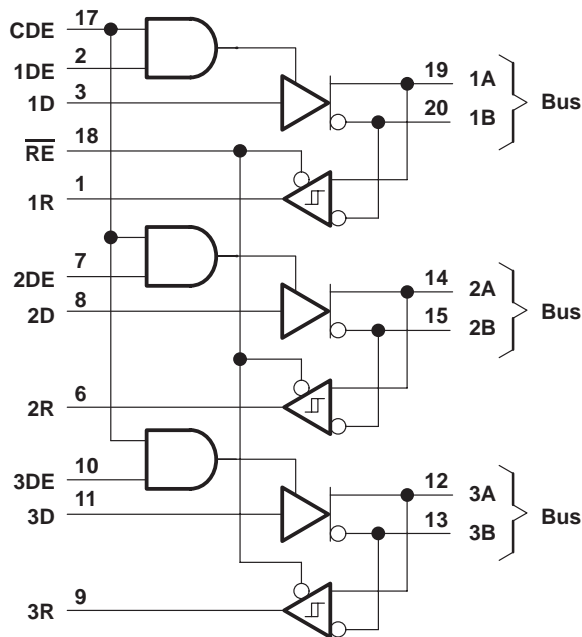

## schematics of inputs and outputs

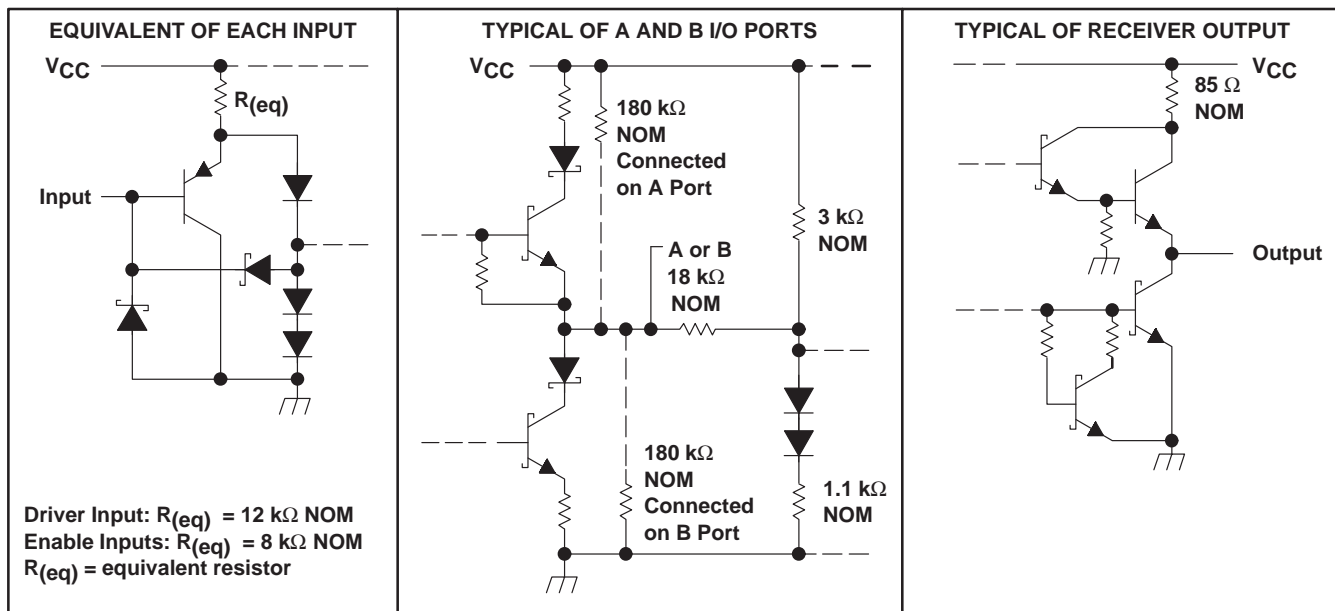

# SN75ALS171, SN75ALS171A TRIPLE DIFFERENTIAL BUS TRANSCEIVERS

SLLS056D – AUGUST 1987 – REVISED SEPTEMBER 1995

## absolute maximum ratings over operating free-air temperature range (unless otherwise noted)†

Supply voltage, $V_{CC}$ (see Note 1)	7 V
Voltage range at any bus terminal	-7 V to 12 V
Enable input voltage, $V_I$	7 V
Continuous total power dissipation	See Dissipation Rating Table
Operating free-air temperature range, $T_A$	0°C to 70°C
Storage temperature range, $T_{stg}$	-65°C to 150°C
Lead temperature 1,6 mm (1/16 inch) from case for 10 seconds: DW package	260°C
Lead temperature 1,6 mm (1/16 inch) from case for 60 seconds: J package	300°C

† Stresses beyond those listed under “absolute maximum ratings” may cause permanent damage to the device. These are stress ratings only, and functional operation of the device at these or any other conditions beyond those indicated under “recommended operating conditions” is not implied. Exposure to absolute-maximum-rated conditions for extended periods may affect device reliability.

NOTE 1: All voltage values, except differential I/O bus voltage, are with respect to network ground terminal.

DISSIPATION RATING TABLE

PACKAGE	$T_A \leq 25^\circ\text{C}$ POWER RATING	DERATING FACTOR ABOVE $T_A = 25^\circ\text{C}$	$T_A = 70^\circ\text{C}$ POWER RATING
DW	1125 mW	9.0 mW/°C	720 mW
J	1025 mW	8.2 mW/°C	656 mW

## recommended operating conditions

	MIN	NOM	MAX	UNIT
Supply voltage, $V_{CC}$	4.75	5	5.25	V
Voltage at any bus terminal (separately or common mode), $V_I$ or $V_{IC}$	-7		12	V
High-level input voltage, $V_{IH}$	D, CDE, DE, and $\overline{RE}$		2	V
Low-level input voltage, $V_{IL}$	D, CDE, DE, and $\overline{RE}$		0.8	V
Differential input voltage, $V_{ID}$ (see Note 2)			±12	V
High-level output current, $I_{OH}$	Driver		-60	mA
	Receiver		-400	µA
Low-level output current, $I_{OL}$	Driver		60	mA
	Receiver		8	
Operating free-air temperature, $T_A$	0		70	°C

NOTE 2: Differential-input/output bus voltage is measured at the noninverting terminal A with respect to the inverting terminal B.



# SN75ALS171, SN75ALS171A TRIPLE DIFFERENTIAL BUS TRANSCEIVERS

SLLS056D – AUGUST 1987 – REVISED SEPTEMBER 1995

## DRIVER SECTION

**electrical characteristics over recommended ranges of supply voltage and operating free-air temperature (unless otherwise noted)**

PARAMETER		TEST CONDITIONST		MIN	TYP‡	MAX	UNIT		
V <sub>IK</sub>	Input clamp voltage	I <sub>I</sub> = -18 mA				-1.5	V		
V <sub>O</sub>	Output voltage	I <sub>O</sub> = 0		0		6	V		
V <sub>OH</sub>	High-level output voltage	V <sub>CC</sub> = 4.75 V, V <sub>IL</sub> = 0.8 V,	V <sub>IH</sub> = 2 V, I <sub>OH</sub> = -55 mA	2.7			V		
V <sub>OL</sub>	Low-level output voltage	V <sub>CC</sub> = 4.75 V, V <sub>IL</sub> = 0.8 V,	V <sub>IH</sub> = 2 V, I <sub>OL</sub> = 55 mA			1.7	V		
V <sub>OD1</sub>	Differential output voltage	I <sub>O</sub> = 0		1.5		6	V		
V <sub>OD2</sub>	Differential output voltage	R <sub>L</sub> = 100 Ω,	See Figure 1	1/2 V <sub>OD1</sub> or 2§	2.5	5	V		
		R <sub>L</sub> = 54 Ω,	See Figure 1	1.5	2.5	5			
V <sub>OD3</sub>	Differential output voltage	V <sub>test</sub> = -7 V to 12 V, See Figure 2		1.5		5	V		
Δ V <sub>OD</sub>	Change in magnitude of differential output voltage¶	R <sub>L</sub> = 54 Ω or 100 Ω, See Figure 1				±0.2	V		
V <sub>OC</sub>	Common-mode output voltage					3	-1	V	
Δ V <sub>OC</sub>	Change in magnitude of common-mode output voltage¶							±0.2	V
I <sub>O</sub>	Output current	Output disabled, See Note 3		V <sub>O</sub> = 12 V		1	mA		
				V <sub>O</sub> = -7 V		-0.8			
I <sub>IH</sub>	High-level enable-input current	D and DE CDE		V <sub>IH</sub> = 2.7 V		20	μA		
						60			
I <sub>IL</sub>	Low-level enable-input current	D and DE CDE		V <sub>IL</sub> = 0.4 V		-100	μA		
						-900			
I <sub>OS</sub>	Short-circuit output current					V <sub>O</sub> = -6 V	-250		
						V <sub>O</sub> = 0	-150		
						V <sub>O</sub> = V <sub>CC</sub>	250		
						V <sub>O</sub> = 8 V	250		
I <sub>CC</sub>	Supply current	No load				Outputs enabled	69	90	mA
						Outputs disabled	57	78	

† The power-off measurement in ANSI Standard EIA/TIA-422-B applies to disabled outputs only and is not applied to combined inputs and outputs.

‡ All typical values are at V<sub>CC</sub> = 5 V and T<sub>A</sub> = 25°C.

§ The minimum V<sub>OD2</sub> with 100-Ω load is either 1/2 V<sub>OD2</sub> or 2 V, whichever is greater.

¶ Δ|V<sub>OD</sub>| and Δ|V<sub>OC</sub>| are the changes in magnitude of V<sub>OD</sub> and V<sub>OC</sub>, respectively, that occur when the input is changed from a high level to a low level.

NOTE 3: This applies for both power on and off; refer to EIA Standard RS-485 for exact conditions. The EIA/TIA-422-B limit does not apply for a combined driver and receiver terminal.

# SN75ALS171, SN75ALS171A

## TRIPLE DIFFERENTIAL BUS TRANSCEIVERS

SLLS056D – AUGUST 1987 – REVISED SEPTEMBER 1995

switching characteristics over recommended ranges of supply voltage and operating free-air temperature (unless otherwise noted)

PARAMETER		TEST CONDITIONS		MIN	TYP†	MAX	UNIT
t <sub>d(OD)</sub>	Differential output delay time	ALS171	R <sub>L</sub> = 54 Ω, See Figure 3, C <sub>L</sub> = 50 pF	3		13	ns
		ALS171A					
		ALS171	R <sub>L1</sub> = R <sub>L3</sub> = 165 Ω, C <sub>L</sub> = 60 pF, R <sub>L2</sub> = 75 Ω, V <sub>TERM</sub> = 5 V, See Figure 6	3		13	
		ALS171A					
t <sub>sk(p)</sub>	Pulse skew‡	R <sub>L</sub> = 54 Ω, See Figure 3, C <sub>L</sub> = 50 pF,			1	5	ns
		R <sub>L1</sub> = R <sub>L3</sub> = 165 Ω, R <sub>L2</sub> = 75 Ω, C <sub>L</sub> = 60 pF, See Figure 6			1	5	ns
t <sub>sk(lim)</sub>	Skew limit§	ALS171	R <sub>L</sub> = 54 Ω, See Figure 3	C <sub>L</sub> = 50 pF,		10	ns
		ALS171A					
		ALS171	R <sub>L1</sub> = R <sub>L3</sub> = 165 Ω, C <sub>L</sub> = 60 pF, R <sub>L2</sub> = 75 Ω, See Figure 6		10		
		ALS171A				5	
t <sub>t(OD)</sub>	Differential-output transition time	R <sub>L</sub> = 54 Ω, See Figure 3, C <sub>L</sub> = 50 pF,		3	8	13	ns
		R <sub>L1</sub> = R <sub>L3</sub> = 165 Ω, R <sub>L2</sub> = 75 Ω, C <sub>L</sub> = 60 pF, V <sub>TERM</sub> = 5 V, See Figure 6		3	8	13	
t <sub>pZH</sub>	Output enable time to high level	R <sub>L</sub> = 110 Ω, See Figure 4			30	50	ns
t <sub>pZL</sub>	Output enable time to low level	R <sub>L</sub> = 110 Ω, See Figure 5			30	50	ns
t <sub>PHZ</sub>	Output disable time from high level	R <sub>L</sub> = 110 Ω, See Figure 4		3	8	13	ns
t <sub>PLZ</sub>	Output disable time from low level	R <sub>L</sub> = 110 Ω, See Figure 5		3	8	13	ns
t <sub>pDE</sub>	Differential-output enable time	R <sub>L1</sub> = R <sub>L3</sub> = 165 Ω, R <sub>L2</sub> = 75 Ω, C <sub>L</sub> = 60 pF, See Figure 7		8	30	45	ns
t <sub>pDZ</sub>	Differential-output disable time			5	10	45	ns

† All typical values are at V<sub>CC</sub> = 5 V and T<sub>A</sub> = 25°C.

‡ Pulse skew is defined as the |t<sub>d(ODH)</sub> - t<sub>d(ODL)</sub>| of each channel.

§ Skew limit is the maximum difference in propagation delay times between any two channels of one device and between any two devices. This parameter is applicable at one V<sub>CC</sub> and operating temperature within the recommended operating conditions.

### SYMBOL EQUIVALENTS

DATA-SHEET PARAMETER	EIA/TIA-422-B	RS-485
V <sub>O</sub>	V <sub>0a</sub> , V <sub>0b</sub>	V <sub>0a</sub> , V <sub>0b</sub>
V <sub>OD1</sub>	V <sub>0</sub>	V <sub>0</sub>
V <sub>OD2</sub>	V <sub>t</sub> (R <sub>L</sub> = 100 Ω)	V <sub>t</sub> (R <sub>L</sub> = 54 Ω)
V <sub>OD3</sub>		V <sub>t</sub> (Test Termination Measurement 2)
V <sub>tst</sub>		V <sub>tst</sub>
Δ V <sub>OD</sub>	V <sub>t</sub>   -  V̄ <sub>t</sub>	V <sub>t</sub>   -  V̄ <sub>t</sub>
V <sub>OC</sub>	V <sub>os</sub>	V <sub>os</sub>
Δ V <sub>OC</sub>	V <sub>os</sub> - V̄ <sub>os</sub>	V <sub>os</sub> - V̄ <sub>os</sub>
I <sub>OS</sub>	I <sub>sa</sub>  ,  I <sub>sb</sub>	
I <sub>O</sub>	I <sub>xa</sub>  ,  I <sub>xb</sub>	I <sub>ia</sub> , I <sub>ib</sub>



# SN75ALS171, SN75ALS171A TRIPLE DIFFERENTIAL BUS TRANSCEIVERS

SLLS056D – AUGUST 1987 – REVISED SEPTEMBER 1995

## RECEIVER SECTION

**electrical characteristics over recommended ranges of common-mode input voltage, supply voltage, and operating free-air temperature (unless otherwise noted)**

PARAMETER		TEST CONDITIONS		MIN	TYP†	MAX	UNIT
$V_{IT+}$	Positive-going input threshold voltage	$V_O = 2.7\text{ V}$ ,	$I_O = -0.4\text{ mA}$			0.3	V
$V_{IT-}$	Negative-going input threshold voltage	$V_O = 0.5\text{ V}$ ,	$I_O = 8\text{ mA}$	$-0.3\ddagger$			V
$V_{hys}$	Hysteresis voltage ( $V_{IT+} - V_{IT-}$ )				60		mV
$V_{IK}$	Enable-input clamp voltage	$I_I = -18\text{ mA}$				-1.5	V
$V_{OH}$	High-level output voltage	$V_{ID} = 300\text{ mV}$ , See Figure 8	$I_{OH} = -400\text{ }\mu\text{A}$ ,		2.7		V
$V_{OL}$	Low-level output voltage	$V_{ID} = -300\text{ mV}$ , See Figure 8	$I_{OL} = 8\text{ mA}$ ,			0.45	V
$I_{OZ}$	High-impedance-state output current	$V_O = 0.4\text{ V to }2.4\text{ V}$				$\pm 20$	$\mu\text{A}$
$I_I$	Line input current	Other input = 0 V, See Note 4	$V_I = 12\text{ V}$			1	mA
			$V_I = -7\text{ V}$			-0.8	
$I_{IH}$	High-level enable-input current	$V_{IH} = 2.7\text{ V}$				60	$\mu\text{A}$
$I_{IL}$	Low-level enable-input current	$V_{IL} = 0.4\text{ V}$				-300	$\mu\text{A}$
$r_i$	Input resistance				12		k $\Omega$
$I_{OS}$	Short-circuit output current	$V_{ID} = 300\text{ mV}$ ,	$V_O = 0$	-15		-85	mA
$I_{CC}$	Supply current	No load	Outputs enabled		69	90	mA
			Outputs disabled		57	78	

† All typical values are at  $V_{CC} = 5\text{ V}$  and  $T_A = 25^\circ\text{C}$ .

‡ The algebraic convention, in which the less positive (more negative) limit is designated minimum, is used in this data sheet for common-mode input voltage and threshold voltage levels only.

NOTE 4: This applies for both power on and off; refer to EIA Standard RS-485 for exact conditions.

**switching characteristics over recommended ranges of supply voltage and operating free-air temperature range**

PARAMETER		TEST CONDITIONS	MIN	TYP†	MAX	UNIT
$t_{PLH}$	Propagation delay time, low- to high-level output	$V_{ID} = -1.5\text{ V to }1.5\text{ V}$ , $C_L = 15\text{ pF}$ , $T_A = 25^\circ\text{C}$ , See Figure 9	9		19	ns
			11		16	
$t_{PHL}$	Propagation delay time, high- to low-level output	$V_{ID} = -1.5\text{ V to }1.5\text{ V}$ , $C_L = 15\text{ pF}$ , $T_A = 25^\circ\text{C}$ , See Figure 9	9		19	ns
			11		16	
$t_{sk(p)}$	Pulse skew§	$V_{ID} = -1.5\text{ V to }1.5\text{ V}$ , $C_L = 15\text{ pF}$ , See Figure 9		2	5	ns
$t_{sk(lim)}$	Skew limit¶		ALS171			10
		ALS171A			5	
$t_{PZH}$	Output enable time to high level	$C_L = 15\text{ pF}$ , See Figure 10		7	14	ns
$t_{PZL}$	Output enable time to low level			7	14	ns
$t_{PHZ}$	Output disable time from high level	$C_L = 15\text{ pF}$ , See Figure 10		20	35	ns
$t_{PLZ}$	Output disable time from low level			8	17	ns

† All typical values are at  $V_{CC} = 5\text{ V}$  and  $T_A = 25^\circ\text{C}$ .

§ Pulse skew is defined as the  $|t_{PLH} - t_{PHL}|$  of each channel.

¶ Skew limit is the maximum difference in propagation delay times between any two channels of one device and between any two devices. This parameter is applicable at one  $V_{CC}$  and operating temperature within the recommended operating conditions.



# SN75ALS171, SN75ALS171A TRIPLE DIFFERENTIAL BUS TRANSCEIVERS

SLLS056D – AUGUST 1987 – REVISED SEPTEMBER 1995

## PARAMETER MEASUREMENT INFORMATION

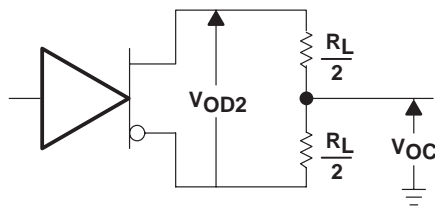

Figure 1. Driver  $V_{OD}$  and  $V_{OC}$

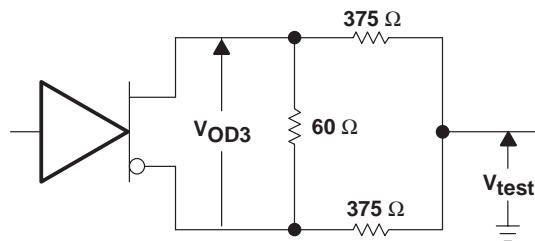
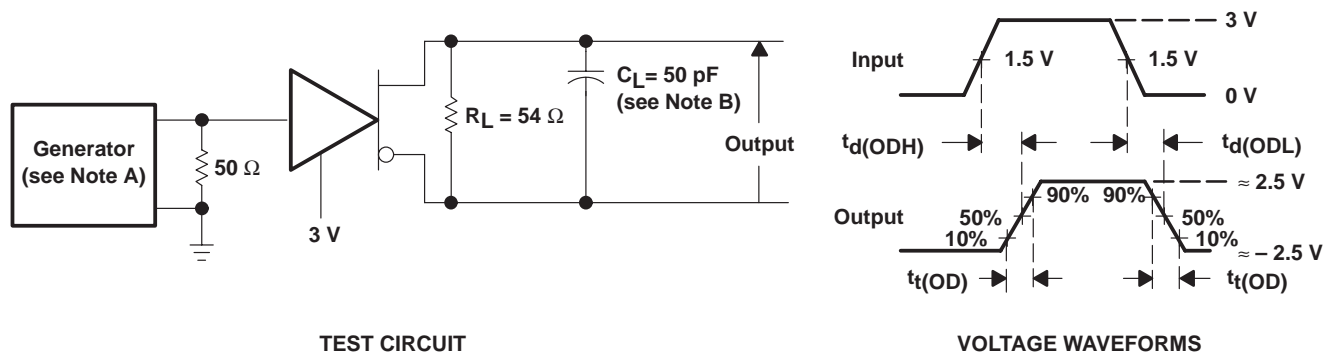

Figure 2. Driver  $V_{OD3}$



- NOTES: A. The input pulse is supplied by a generator having the following characteristics:  $PRR \leq 1$  MHz, 50% duty cycle,  $t_r \leq 6$  ns,  $t_f \leq 6$  ns,  $Z_O = 50 \Omega$ .  
 B.  $C_L$  includes probe and jig capacitance.

Figure 3. Driver Test Circuit and Voltage Waveforms



## PARAMETER MEASUREMENT INFORMATION

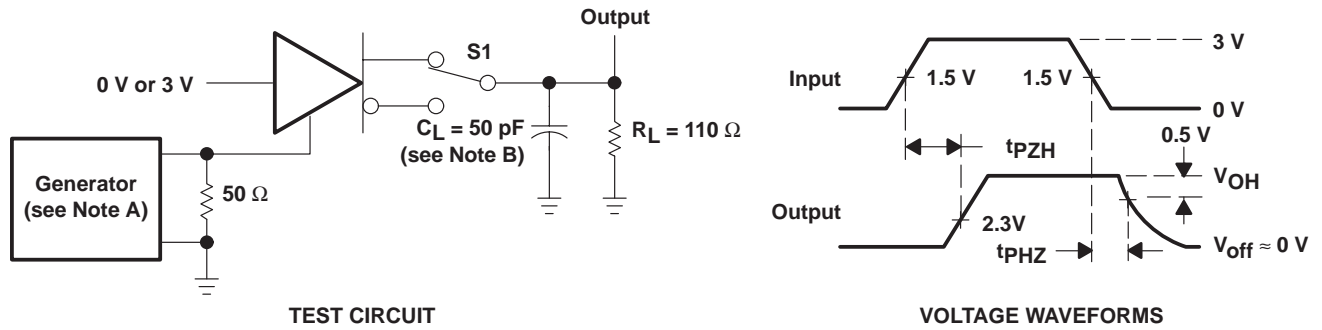

- NOTES: A. The input pulse is supplied by a generator having the following characteristics: PRR  $\leq$  1 MHz, 50% duty cycle,  $t_r \leq$  6 ns,  $t_f \leq$  6 ns,  $Z_O = 50 \Omega$ .  
 B.  $C_L$  includes probe and jig capacitance.

**Figure 4. Driver Test Circuit and Voltage Waveforms**

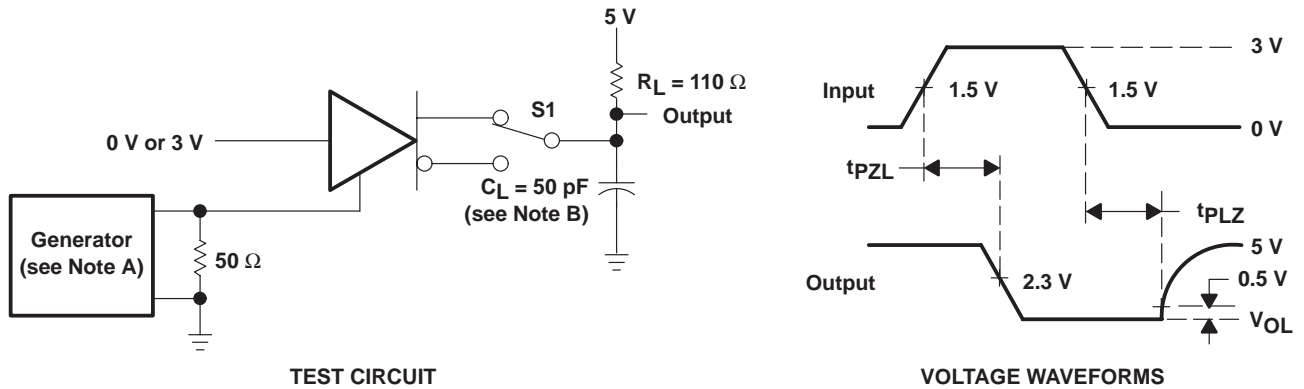

- NOTES: A. The input pulse is supplied by a generator having the following characteristics: PRR  $\leq$  1 MHz, 50% duty cycle,  $t_r \leq$  6 ns,  $t_f \leq$  6 ns,  $Z_O = 50 \Omega$ .  
 B.  $C_L$  includes probe and jig capacitance.

**Figure 5. Driver Test Circuit and Voltage Waveforms**

# SN75ALS171, SN75ALS171A TRIPLE DIFFERENTIAL BUS TRANSCEIVERS

SLLS056D – AUGUST 1987 – REVISED SEPTEMBER 1995

## PARAMETER MEASUREMENT INFORMATION

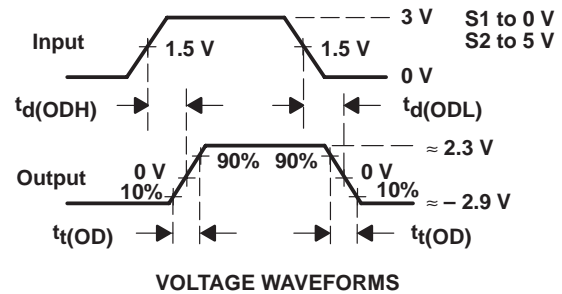
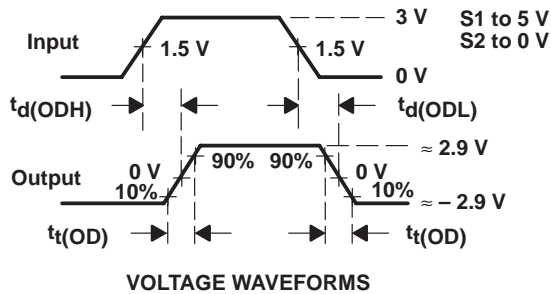
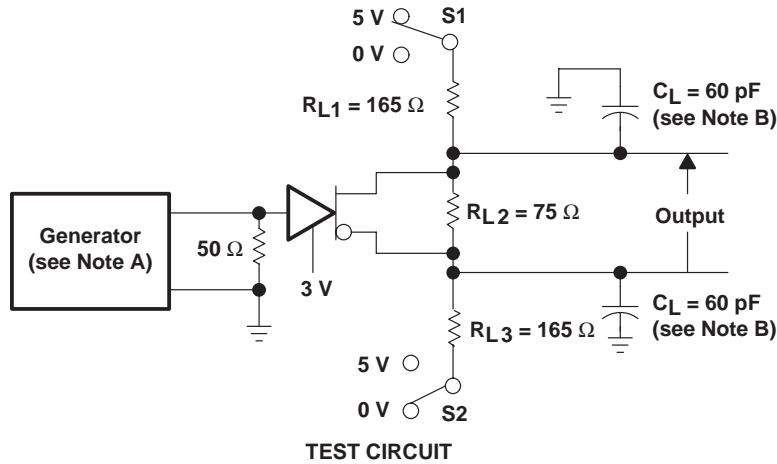

- NOTES: A. The input pulse is supplied by a generator having the following characteristics: PRR  $\leq$  1 MHz, 50% duty cycle,  $t_r \leq$  6 ns,  $t_f \leq$  6 ns,  $Z_O = 50 \Omega$ .  
 B.  $C_L$  includes probe and jig capacitance.

**Figure 6. Driver Test Circuit and Voltage Waveforms  
With Double-Differential-SCSI Termination for the Load**

PARAMETER MEASUREMENT INFORMATION

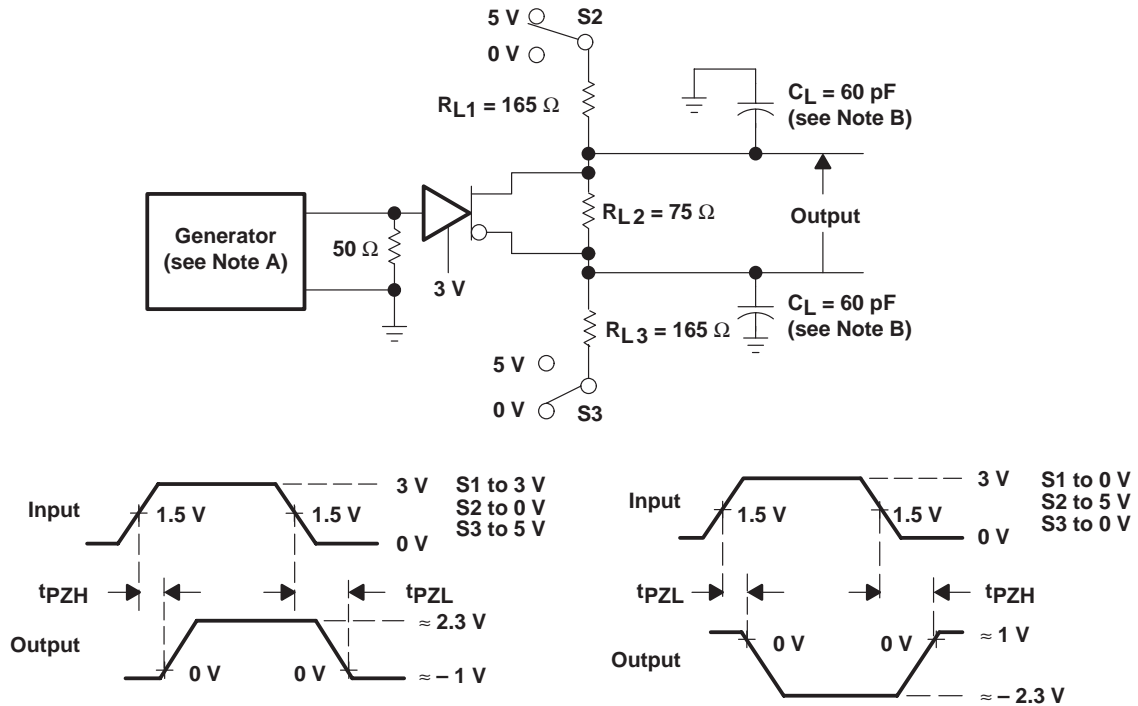

- NOTES: A. The input pulse is supplied by a generator having the following characteristics: PRR ≤ 1 MHz, 50% duty cycle, t<sub>r</sub> ≤ 6 ns, t<sub>f</sub> ≤ 6 ns, Z<sub>O</sub> = 50 Ω.  
 B. C<sub>L</sub> includes probe and jig capacitance.

Figure 7. Driver Differential-Enable and Disable Times With a Double-SCSI Termination

# SN75ALS171, SN75ALS171A TRIPLE DIFFERENTIAL BUS TRANSCEIVERS

SLLS056D – AUGUST 1987 – REVISED SEPTEMBER 1995

## PARAMETER MEASUREMENT INFORMATION

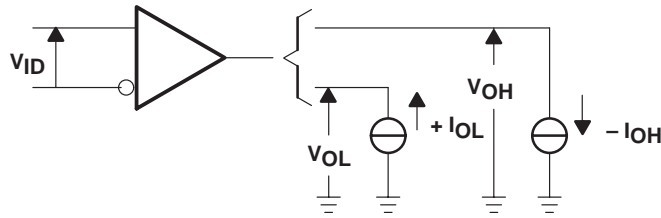
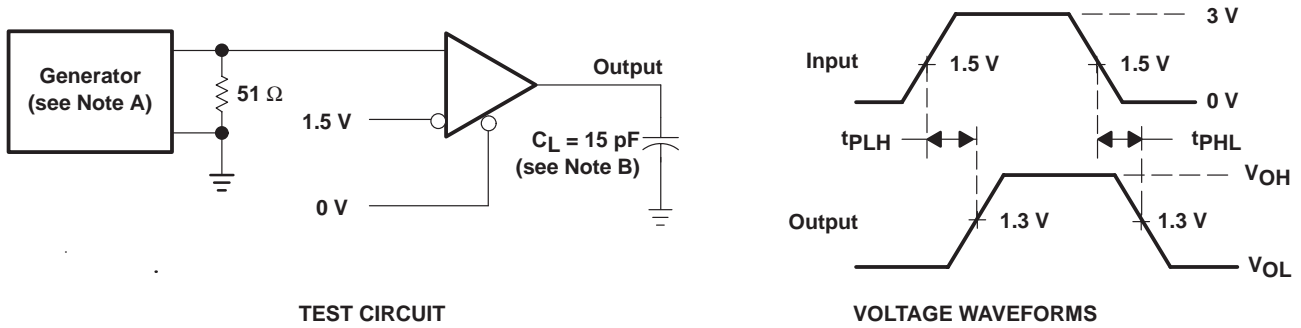

Figure 8. Receiver  $V_{OH}$  and  $V_{OL}$



TEST CIRCUIT

VOLTAGE WAVEFORMS

- NOTES: A. The input pulse is supplied by a generator having the following characteristics: PRR  $\leq$  1 MHz, 50% duty cycle,  $t_r \leq$  6 ns,  $t_f \leq$  6 ns,  $Z_O = 50 \Omega$ .  
 B.  $C_L$  includes probe and jig capacitance.

Figure 9. Receiver Test Circuit and Voltage Waveforms

## PARAMETER MEASUREMENT INFORMATION

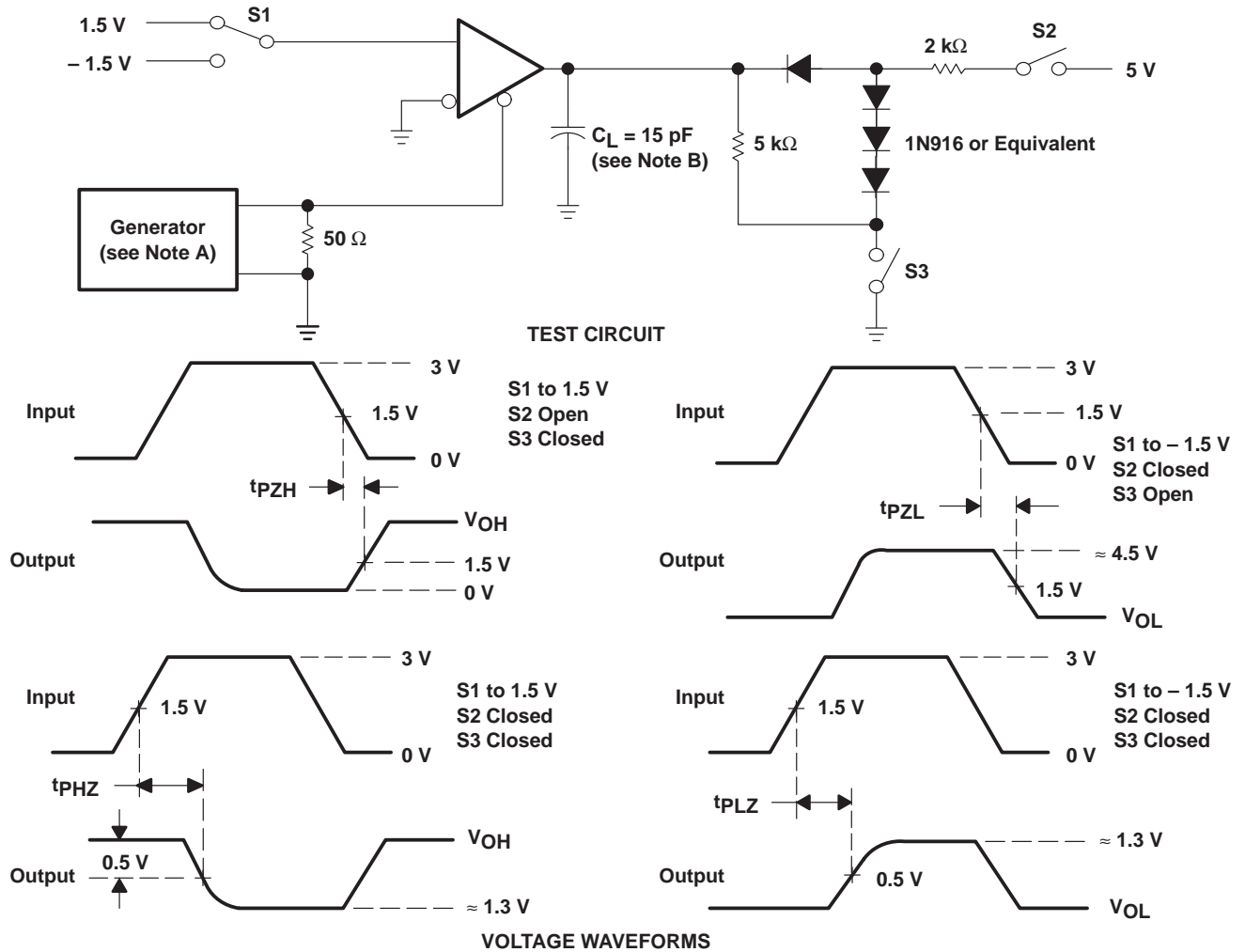

- NOTES: A. The input pulse is supplied by a generator having the following characteristics:  $PRR \leq 1$  MHz, 50% duty cycle,  $t_r \leq 6$  ns,  $t_f \leq 6$  ns,  $Z_O = 50 \Omega$ .  
 B.  $C_L$  includes probe and jig capacitance.

**Figure 10. Receiver Test Circuit and Voltage Waveforms**

# SN75ALS171, SN75ALS171A TRIPLE DIFFERENTIAL BUS TRANSCEIVERS

SLLS056D – AUGUST 1987 – REVISED SEPTEMBER 1995

## TYPICAL CHARACTERISTICS

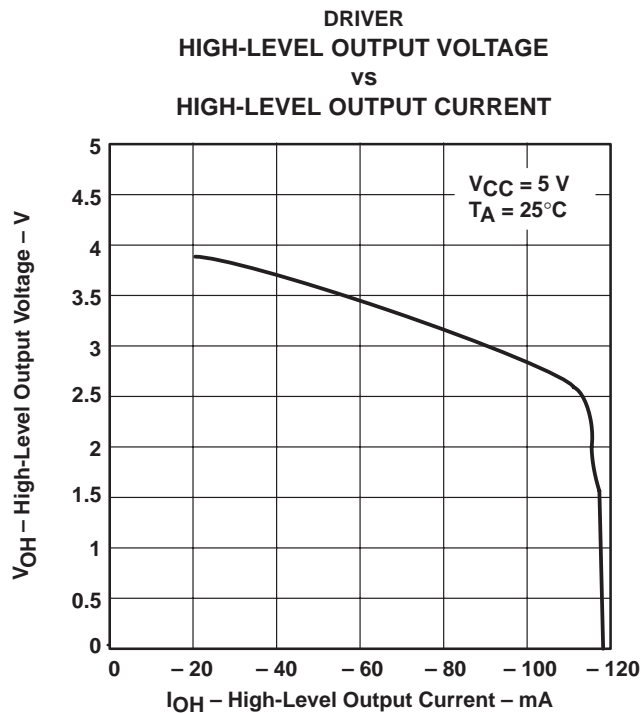

Figure 11

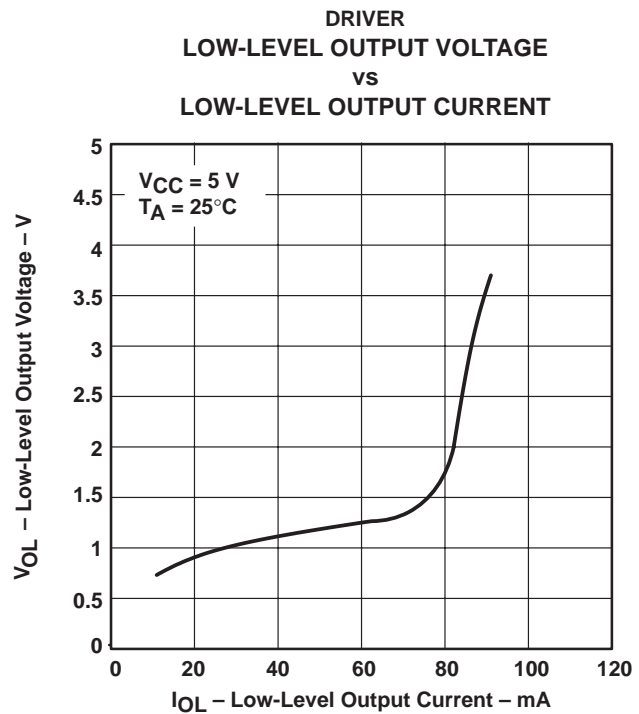

Figure 12

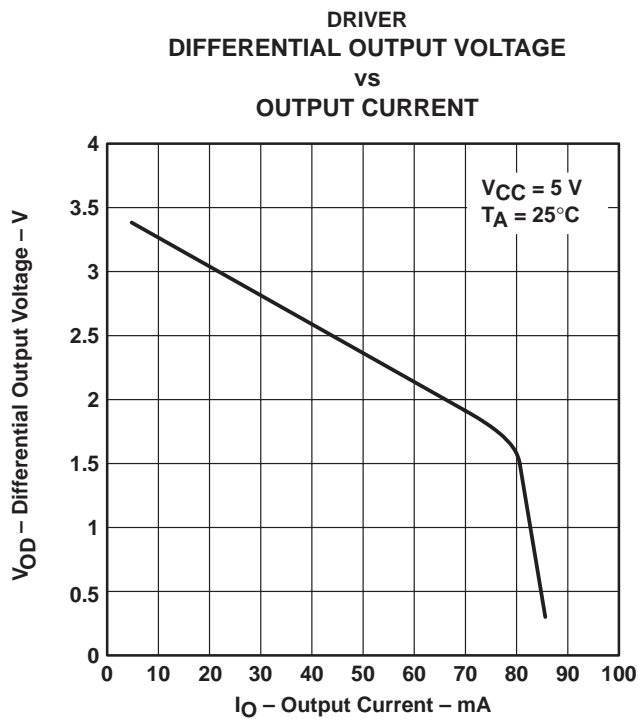

Figure 13



TYPICAL CHARACTERISTICS

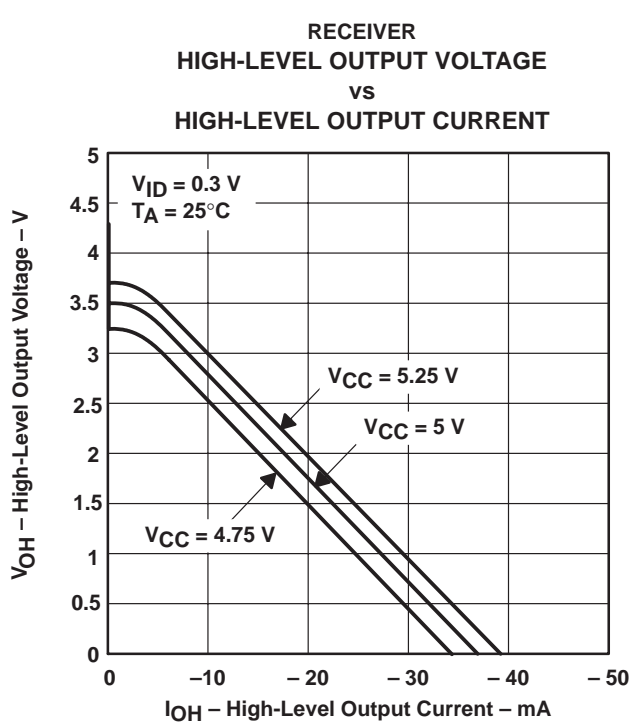

Figure 14

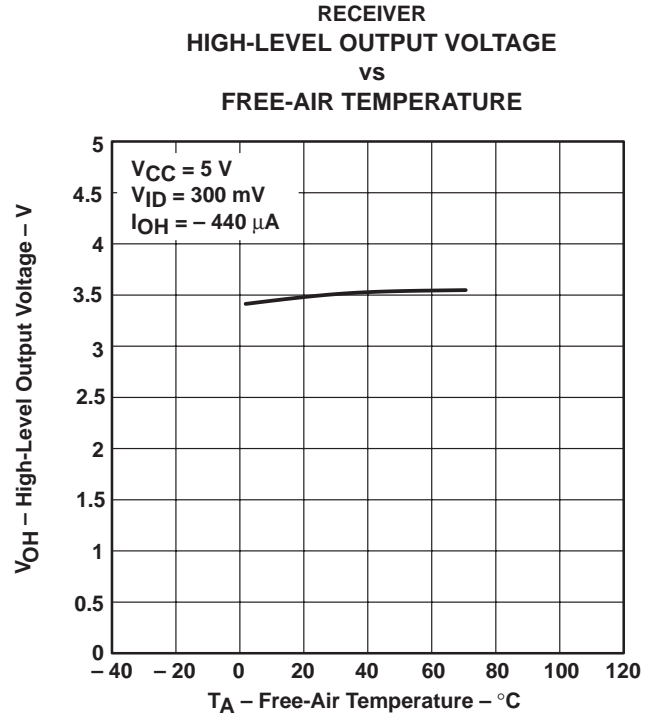

Figure 15

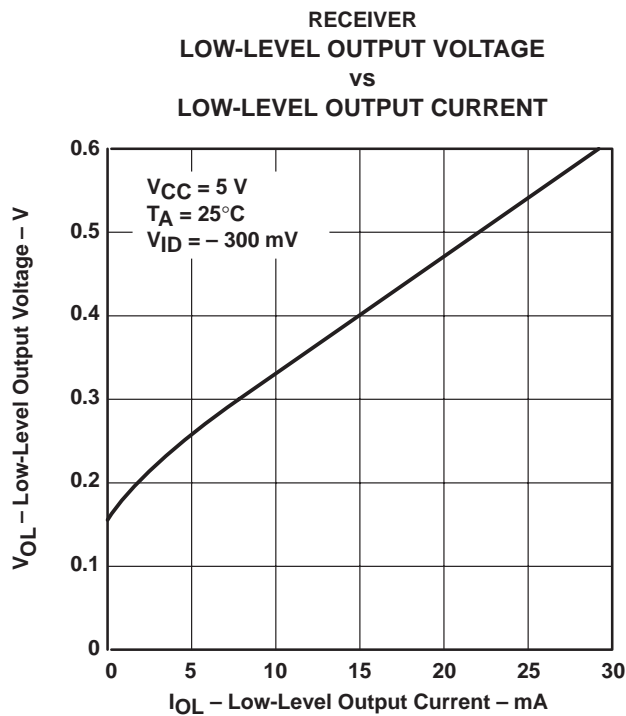

Figure 16

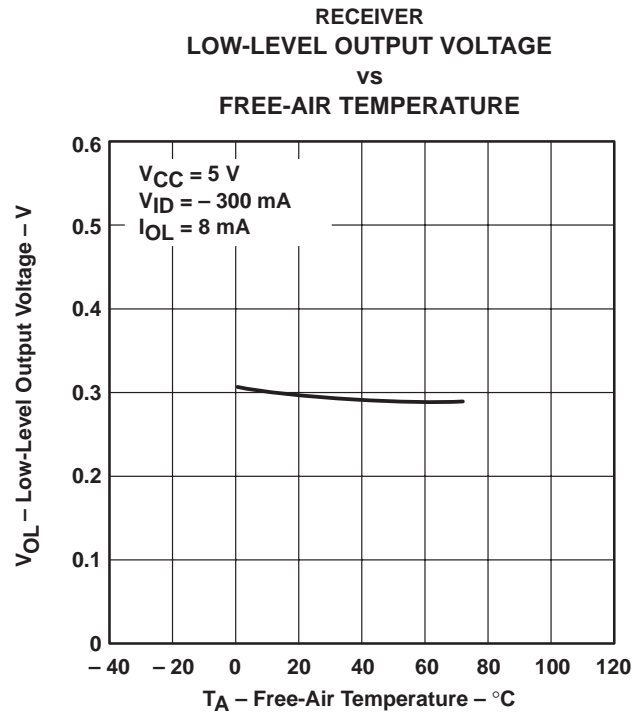

Figure 17

# SN75ALS171, SN75ALS171A TRIPLE DIFFERENTIAL BUS TRANSCEIVERS

SLLS056D – AUGUST 1987 – REVISED SEPTEMBER 1995

## TYPICAL CHARACTERISTICS

RECEIVER  
OUTPUT VOLTAGE  
vs  
ENABLE VOLTAGE

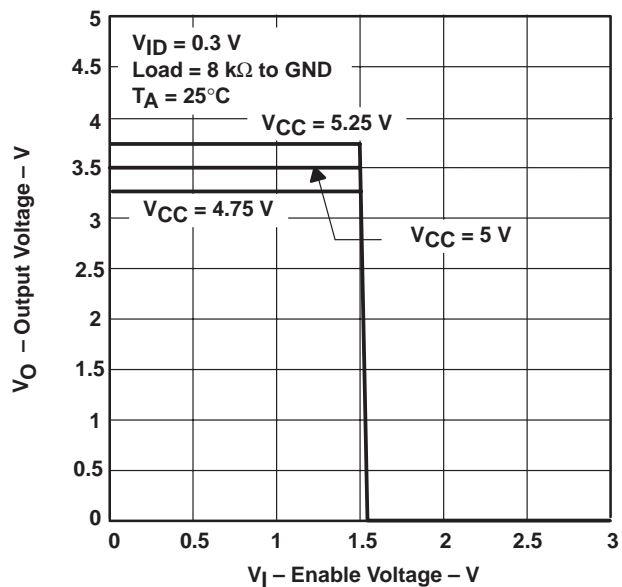

Figure 18

RECEIVER  
OUTPUT VOLTAGE  
vs  
ENABLE VOLTAGE

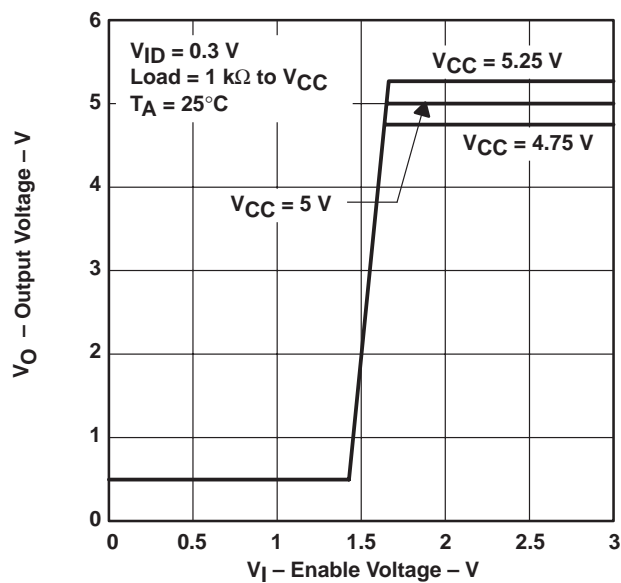
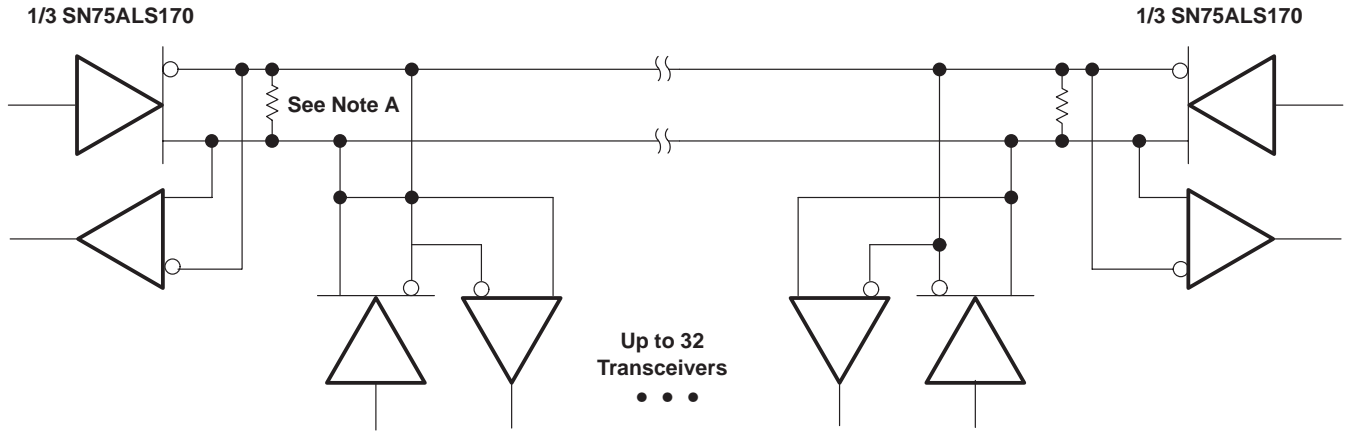

Figure 19



## APPLICATION INFORMATION



NOTE A: The line should be terminated at both ends in its characteristic impedance. Stub lengths off the main line should be kept as short as possible.

**Figure 20. Typical Application Circuit**

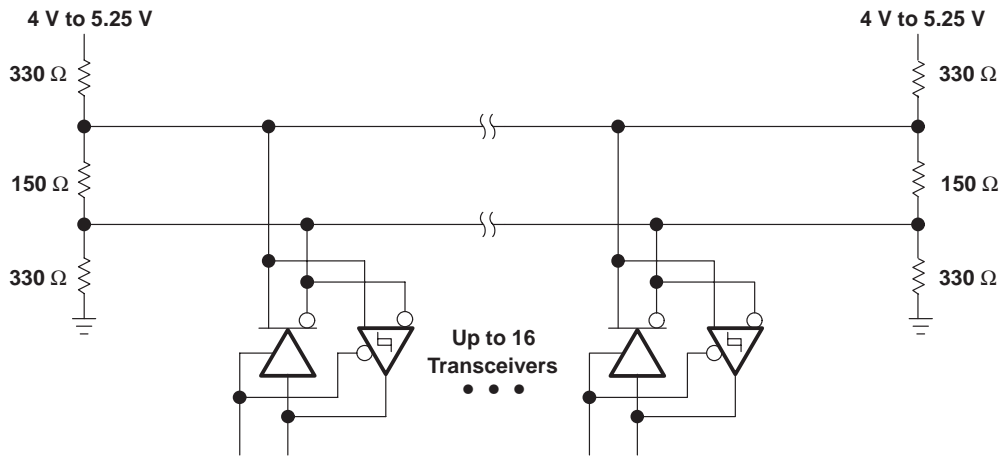

**Figure 21. Typical Differential SCSI Application Circuit**

# SN75ALS171, SN75ALS171A TRIPLE DIFFERENTIAL BUS TRANSCEIVERS

SLLS056D – AUGUST 1987 – REVISED SEPTEMBER 1995

## APPLICATION INFORMATION

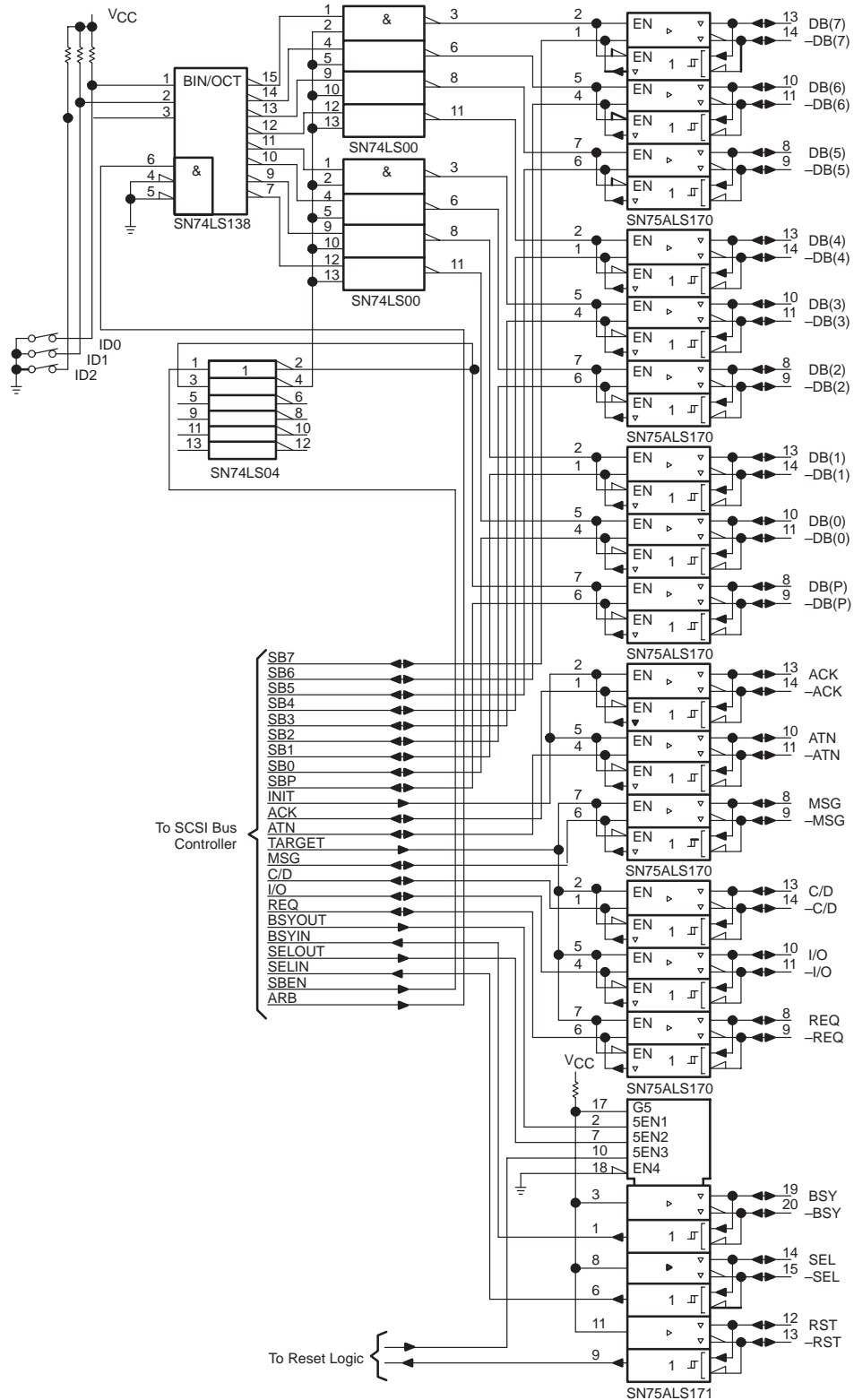

Figure 22. Typical Differential SCSI Bus Interface Implementation

**PACKAGING INFORMATION**

Orderable Device	Status <sup>(1)</sup>	Package Type	Package Drawing	Pins	Package Qty	Eco Plan <sup>(2)</sup>	Lead/Ball Finish	MSL Peak Temp <sup>(3)</sup>
SN75ALS171ADW	ACTIVE	SOIC	DW	20	25	Green (RoHS & no Sb/Br)	CU NIPDAU	Level-1-260C-UNLIM
SN75ALS171ADWE4	ACTIVE	SOIC	DW	20	25	Green (RoHS & no Sb/Br)	CU NIPDAU	Level-1-260C-UNLIM
SN75ALS171ADWR	ACTIVE	SOIC	DW	20	2000	Green (RoHS & no Sb/Br)	CU NIPDAU	Level-1-260C-UNLIM
SN75ALS171ADWRE4	ACTIVE	SOIC	DW	20	2000	Green (RoHS & no Sb/Br)	CU NIPDAU	Level-1-260C-UNLIM
SN75ALS171DW	ACTIVE	SOIC	DW	20	25	Green (RoHS & no Sb/Br)	CU NIPDAU	Level-1-260C-UNLIM
SN75ALS171DWE4	ACTIVE	SOIC	DW	20	25	Green (RoHS & no Sb/Br)	CU NIPDAU	Level-1-260C-UNLIM
SN75ALS171DWR	ACTIVE	SOIC	DW	20	2000	Green (RoHS & no Sb/Br)	CU NIPDAU	Level-1-260C-UNLIM
SN75ALS171DWRE4	ACTIVE	SOIC	DW	20	2000	Green (RoHS & no Sb/Br)	CU NIPDAU	Level-1-260C-UNLIM
SN75ALS171J	OBSOLETE	CDIP	J	20		TBD	Call TI	Call TI

<sup>(1)</sup> The marketing status values are defined as follows:

**ACTIVE:** Product device recommended for new designs.

**LIFEBUY:** TI has announced that the device will be discontinued, and a lifetime-buy period is in effect.

**NRND:** Not recommended for new designs. Device is in production to support existing customers, but TI does not recommend using this part in a new design.

**PREVIEW:** Device has been announced but is not in production. Samples may or may not be available.

**OBSOLETE:** TI has discontinued the production of the device.

<sup>(2)</sup> Eco Plan - The planned eco-friendly classification: Pb-Free (RoHS), Pb-Free (RoHS Exempt), or Green (RoHS & no Sb/Br) - please check <http://www.ti.com/productcontent> for the latest availability information and additional product content details.

**TBD:** The Pb-Free/Green conversion plan has not been defined.

**Pb-Free (RoHS):** TI's terms "Lead-Free" or "Pb-Free" mean semiconductor products that are compatible with the current RoHS requirements for all 6 substances, including the requirement that lead not exceed 0.1% by weight in homogeneous materials. Where designed to be soldered at high temperatures, TI Pb-Free products are suitable for use in specified lead-free processes.

**Pb-Free (RoHS Exempt):** This component has a RoHS exemption for either 1) lead-based flip-chip solder bumps used between the die and package, or 2) lead-based die adhesive used between the die and leadframe. The component is otherwise considered Pb-Free (RoHS compatible) as defined above.

**Green (RoHS & no Sb/Br):** TI defines "Green" to mean Pb-Free (RoHS compatible), and free of Bromine (Br) and Antimony (Sb) based flame retardants (Br or Sb do not exceed 0.1% by weight in homogeneous material)

<sup>(3)</sup> MSL, Peak Temp. -- The Moisture Sensitivity Level rating according to the JEDEC industry standard classifications, and peak solder temperature.

**Important Information and Disclaimer:**The information provided on this page represents TI's knowledge and belief as of the date that it is provided. TI bases its knowledge and belief on information provided by third parties, and makes no representation or warranty as to the accuracy of such information. Efforts are underway to better integrate information from third parties. TI has taken and continues to take reasonable steps to provide representative and accurate information but may not have conducted destructive testing or chemical analysis on incoming materials and chemicals. TI and TI suppliers consider certain information to be proprietary, and thus CAS numbers and other limited information may not be available for release.

In no event shall TI's liability arising out of such information exceed the total purchase price of the TI part(s) at issue in this document sold by TI to Customer on an annual basis.

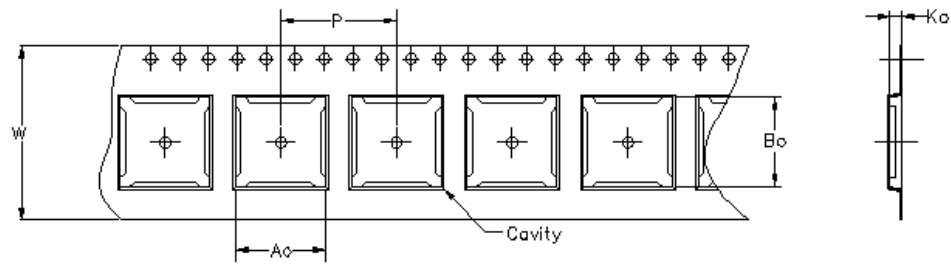

Carrier tape design is defined largely by the component length, width, and thickness.

$A_o$ = Dimension designed to accommodate the component width.
$B_o$ = Dimension designed to accommodate the component length.
$K_o$ = Dimension designed to accommodate the component thickness.
$W$ = Overall width of the carrier tape.
$P$ = Pitch between successive cavity centers.

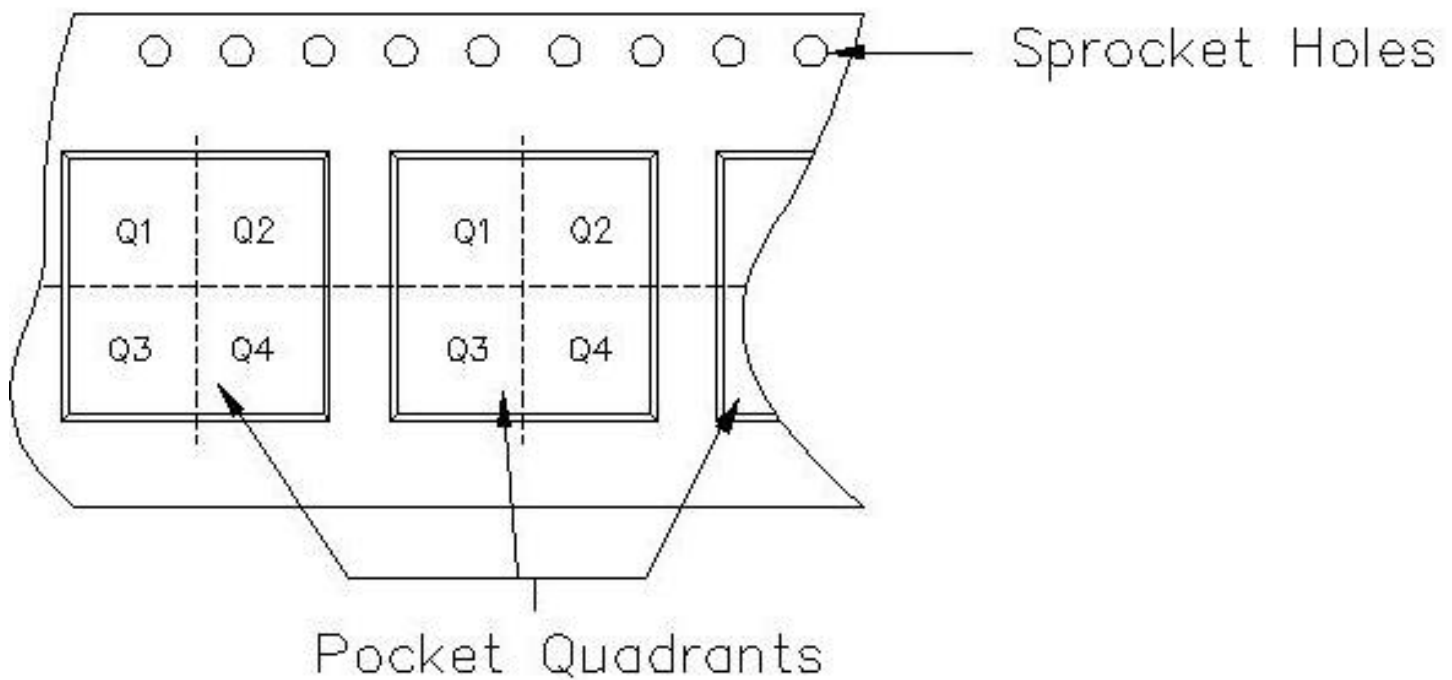

**TAPE AND REEL INFORMATION**

Device	Package	Pins	Site	Reel Diameter (mm)	Reel Width (mm)	A0 (mm)	B0 (mm)	K0 (mm)	P1 (mm)	W (mm)	Pin1 Quadrant
SN75ALS171ADWR	DW	20	TAI	330	24	10.8	13.1	2.65	12	24	Q1
SN75ALS171DWR	DW	20	TAI	330	24	10.8	13.1	2.65	12	24	Q1

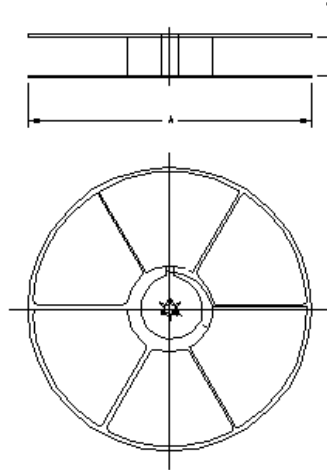

**TAPE AND REEL BOX INFORMATION**

Device	Package	Pins	Site	Length (mm)	Width (mm)	Height (mm)
SN75ALS171ADWR	DW	20	TAI	346.0	346.0	41.0
SN75ALS171DWR	DW	20	TAI	346.0	346.0	41.0

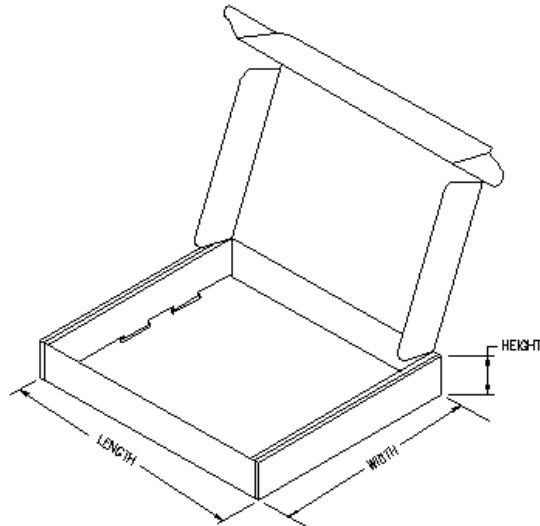

# J (R-GDIP-T\*\*)

14 LEADS SHOWN

# CERAMIC DUAL IN-LINE PACKAGE



DIM \ PINS **	14	16	18	20
A	0.300 (7,62) BSC	0.300 (7,62) BSC	0.300 (7,62) BSC	0.300 (7,62) BSC
B MAX	0.785 (19,94)	.840 (21,34)	0.960 (24,38)	1.060 (26,92)
B MIN	—	—	—	—
C MAX	0.300 (7,62)	0.300 (7,62)	0.310 (7,87)	0.300 (7,62)
C MIN	0.245 (6,22)	0.245 (6,22)	0.220 (5,59)	0.245 (6,22)



4040083/F 03/03

- NOTES:
- All linear dimensions are in inches (millimeters).
  - This drawing is subject to change without notice.
  - This package is hermetically sealed with a ceramic lid using glass frit.
  - Index point is provided on cap for terminal identification only on press ceramic glass frit seal only.
  - Falls within MIL STD 1835 GDIP1-T14, GDIP1-T16, GDIP1-T18 and GDIP1-T20.

DW (R-PDSO-G20)

PLASTIC SMALL-OUTLINE PACKAGE

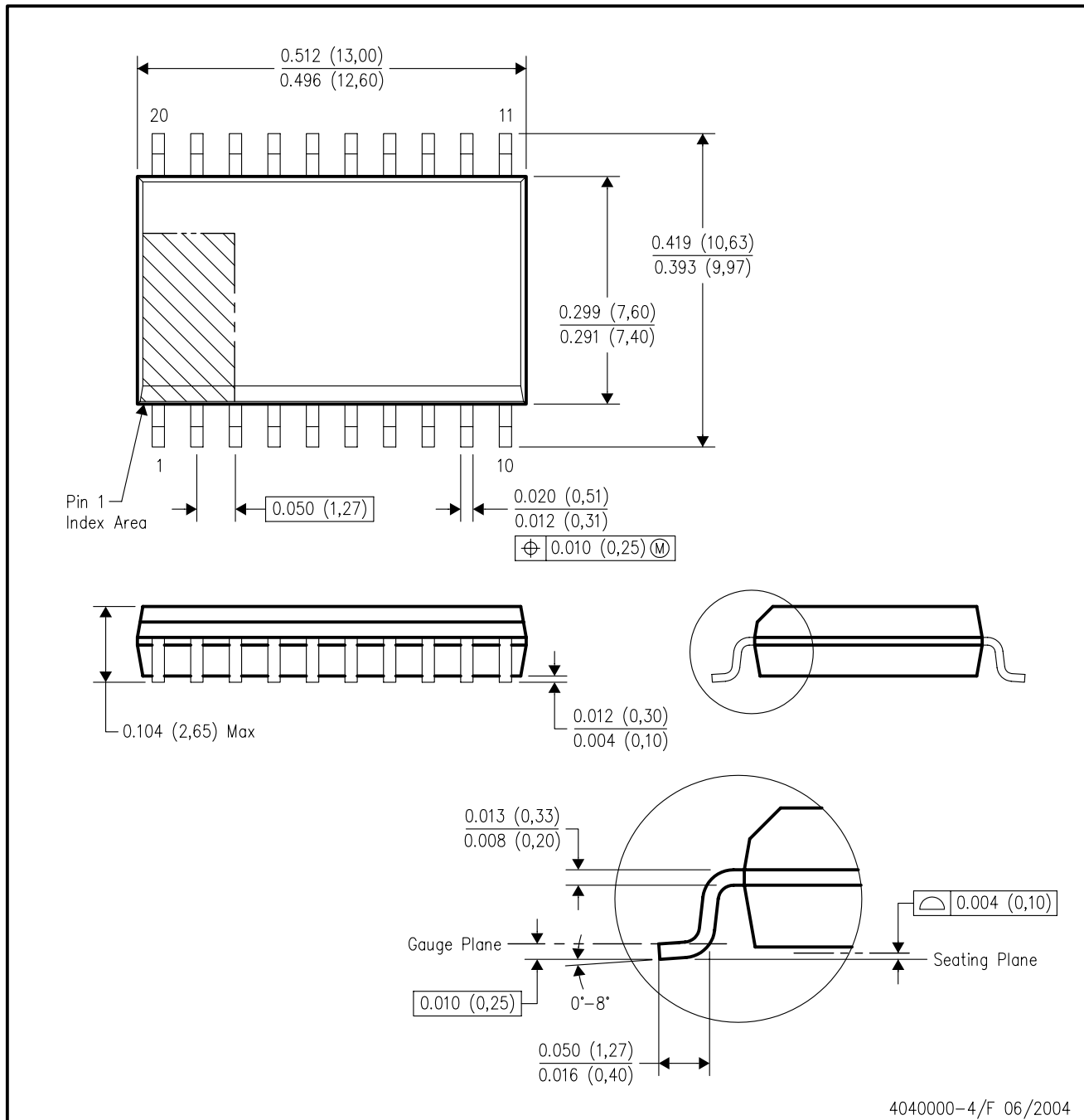

- NOTES:
- A. All linear dimensions are in inches (millimeters).
  - B. This drawing is subject to change without notice.
  - C. Body dimensions do not include mold flash or protrusion not to exceed 0.006 (0,15).
  - D. Falls within JEDEC MS-013 variation AC.

## IMPORTANT NOTICE

Texas Instruments Incorporated and its subsidiaries (TI) reserve the right to make corrections, modifications, enhancements, improvements, and other changes to its products and services at any time and to discontinue any product or service without notice. Customers should obtain the latest relevant information before placing orders and should verify that such information is current and complete. All products are sold subject to TI's terms and conditions of sale supplied at the time of order acknowledgment.

TI warrants performance of its hardware products to the specifications applicable at the time of sale in accordance with TI's standard warranty. Testing and other quality control techniques are used to the extent TI deems necessary to support this warranty. Except where mandated by government requirements, testing of all parameters of each product is not necessarily performed.

TI assumes no liability for applications assistance or customer product design. Customers are responsible for their products and applications using TI components. To minimize the risks associated with customer products and applications, customers should provide adequate design and operating safeguards.

TI does not warrant or represent that any license, either express or implied, is granted under any TI patent right, copyright, mask work right, or other TI intellectual property right relating to any combination, machine, or process in which TI products or services are used. Information published by TI regarding third-party products or services does not constitute a license from TI to use such products or services or a warranty or endorsement thereof. Use of such information may require a license from a third party under the patents or other intellectual property of the third party, or a license from TI under the patents or other intellectual property of TI.

Reproduction of information in TI data books or data sheets is permissible only if reproduction is without alteration and is accompanied by all associated warranties, conditions, limitations, and notices. Reproduction of this information with alteration is an unfair and deceptive business practice. TI is not responsible or liable for such altered documentation.

Resale of TI products or services with statements different from or beyond the parameters stated by TI for that product or service voids all express and any implied warranties for the associated TI product or service and is an unfair and deceptive business practice. TI is not responsible or liable for any such statements.

TI products are not authorized for use in safety-critical applications (such as life support) where a failure of the TI product would reasonably be expected to cause severe personal injury or death, unless officers of the parties have executed an agreement specifically governing such use. Buyers represent that they have all necessary expertise in the safety and regulatory ramifications of their applications, and acknowledge and agree that they are solely responsible for all legal, regulatory and safety-related requirements concerning their products and any use of TI products in such safety-critical applications, notwithstanding any applications-related information or support that may be provided by TI. Further, Buyers must fully indemnify TI and its representatives against any damages arising out of the use of TI products in such safety-critical applications.

TI products are neither designed nor intended for use in military/aerospace applications or environments unless the TI products are specifically designated by TI as military-grade or "enhanced plastic." Only products designated by TI as military-grade meet military specifications. Buyers acknowledge and agree that any such use of TI products which TI has not designated as military-grade is solely at the Buyer's risk, and that they are solely responsible for compliance with all legal and regulatory requirements in connection with such use.

TI products are neither designed nor intended for use in automotive applications or environments unless the specific TI products are designated by TI as compliant with ISO/TS 16949 requirements. Buyers acknowledge and agree that, if they use any non-designated products in automotive applications, TI will not be responsible for any failure to meet such requirements.

Following are URLs where you can obtain information on other Texas Instruments products and application solutions:

<b>Products</b>		<b>Applications</b>	
Amplifiers	<a href="http://amplifier.ti.com">amplifier.ti.com</a>	Audio	<a href="http://www.ti.com/audio">www.ti.com/audio</a>
Data Converters	<a href="http://dataconverter.ti.com">dataconverter.ti.com</a>	Automotive	<a href="http://www.ti.com/automotive">www.ti.com/automotive</a>
DSP	<a href="http://dsp.ti.com">dsp.ti.com</a>	Broadband	<a href="http://www.ti.com/broadband">www.ti.com/broadband</a>
Interface	<a href="http://interface.ti.com">interface.ti.com</a>	Digital Control	<a href="http://www.ti.com/digitalcontrol">www.ti.com/digitalcontrol</a>
Logic	<a href="http://logic.ti.com">logic.ti.com</a>	Military	<a href="http://www.ti.com/military">www.ti.com/military</a>
Power Mgmt	<a href="http://power.ti.com">power.ti.com</a>	Optical Networking	<a href="http://www.ti.com/opticalnetwork">www.ti.com/opticalnetwork</a>
Microcontrollers	<a href="http://microcontroller.ti.com">microcontroller.ti.com</a>	Security	<a href="http://www.ti.com/security">www.ti.com/security</a>
Low Power Wireless	<a href="http://www.ti.com/lpw">www.ti.com/lpw</a>	Telephony	<a href="http://www.ti.com/telephony">www.ti.com/telephony</a>
		Video & Imaging	<a href="http://www.ti.com/video">www.ti.com/video</a>
		Wireless	<a href="http://www.ti.com/wireless">www.ti.com/wireless</a>

Mailing Address: Texas Instruments, Post Office Box 655303, Dallas, Texas 75265  
Copyright © 2007, Texas Instruments Incorporated