

SNx4HC273 Octal D-Type Flip-Flops With Clear

1 Features

- Wide Operating Voltage Range of 2 V to 6 V
- Outputs Can Drive Up to 10 LSTTL Loads
- Low Power Consumption, 80- μ A Maximum I_{CC}
- Typical $t_{pd} = 12$ ns
- ± 4 -mA Output Drive at 5 V
- Low Input Current of 1- μ A Maximum
- Contain Eight Flip-Flops With Single-Rail Outputs
- Direct Clear Input
- Individual Data Input to Each Flip-Flop
- On Products Compliant to MIL-PRF-38535, All Parameters Are Tested Unless Otherwise Noted. On All Other Products, Production Processing Does Not Necessarily Include Testing of All Parameters.

2 Applications

- Buffer or Storage Registers
- Shift Registers
- Pattern Generators

3 Description

The SNx4HC273 devices are positive-edge-triggered D-type flip-flops with a direct active low clear (CLR) input.

Information at the data (D) inputs meeting the setup time requirements is transferred to the Q outputs on the positive-going edge of the clock (CLK) pulse. Clock triggering occurs at a particular voltage level and is not related directly to the transition time of the positive-going pulse. When CLK is at either the high or low level, the D input has no effect at the output.

Device Information⁽¹⁾

PART NUMBER	PACKAGE (PINS)	BODY SIZE (NOM)
SN54HC273J	CDIP (20)	24.20 mm x 6.92 mm
SN54HC273W	CFP (20)	13.09 mm x 6.92 mm
SN54HC273FK	LCCC (20)	8.89 mm x 8.89 mm
SN74HC273D	SOIC (20)	12.80 mm x 7.50 mm
SN74HC273DB	SSOP (20)	7.20 mm x 5.30 mm
SN74HC273NS	SO (20)	12.60 mm x 5.30 mm
SN74HC273N	PDIP (20)	24.33 mm x 6.35 mm
SN74HC273PW	TSSOP (20)	6.50 mm x 4.40 mm

(1) For all available packages, see the orderable addendum at the end of the data sheet.

Logic Diagram, Each Flip-Flop (Positive Logic)

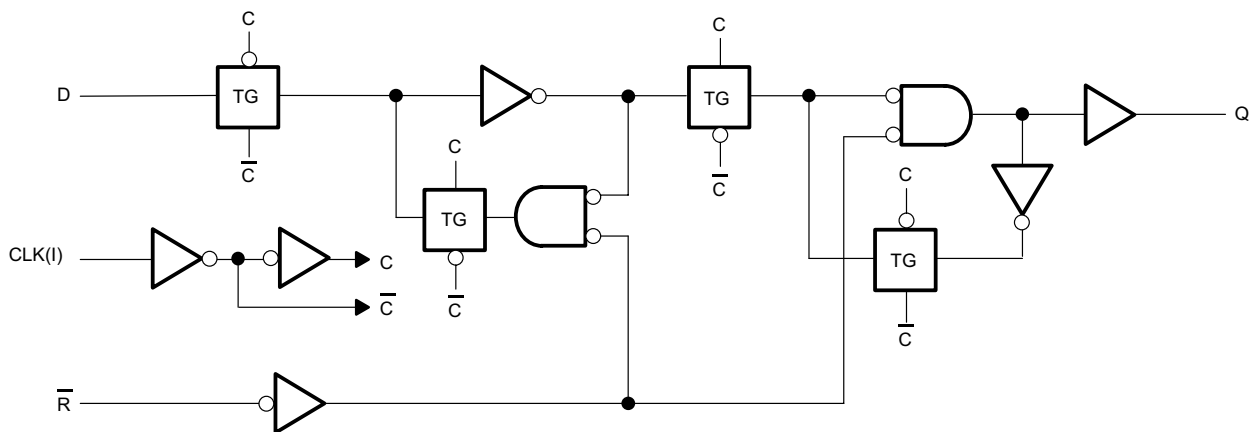

Copyright © 2016, Texas Instruments Incorporated



Table of Contents

1 Features 1 2 Applications 1 3 Description 1 4 Revision History 2 5 Pin Configuration and Functions 3 6 Specifications 4 6.1 Absolute Maximum Ratings 4 6.2 ESD Ratings – SN74HC273 4 6.3 Recommended Operating Conditions 4 6.4 Thermal Information 5 6.5 Electrical Characteristics 5 6.6 Electrical Characteristics – SN54HC273 5 6.7 Electrical Characteristics – SN74HC273 6 6.8 Timing Requirements 6 6.9 Timing Requirements – SN54HC273 7 6.10 Timing Requirements – SN74HC273 7 6.11 Switching Characteristics 8 6.12 Switching Characteristics – SN54HC273 8 6.13 Switching Characteristics – SN74HC273 8 6.14 Operating Characteristics 9 6.15 Typical Characteristics 9 7 Parameter Measurement Information 10	8 Detailed Description 11 8.1 Overview 11 8.2 Functional Block Diagram 11 8.3 Feature Description 11 8.4 Device Functional Modes 11 9 Application and Implementation 12 9.1 Application Information 12 9.2 Typical Application 12 10 Power Supply Recommendations 13 11 Layout 13 11.1 Layout Guidelines 13 11.2 Layout Example 13 12 Device and Documentation Support 14 12.1 Documentation Support 14 12.2 Related Links 14 12.3 Receiving Notification of Documentation Updates 14 12.4 Community Resources 14 12.5 Trademarks 14 12.6 Electrostatic Discharge Caution 14 12.7 Glossary 14 13 Mechanical, Packaging, and Orderable Information 14
---	--

4 Revision History

NOTE: Page numbers for previous revisions may differ from page numbers in the current version.

Changes from Revision D (August 2003) to Revision E	Page
• Added <i>Device Information</i> table, <i>ESD Ratings</i> table, <i>Thermal Information</i> table, <i>Feature Description</i> section, <i>Device Functional Modes</i> , <i>Application and Implementation</i> section, <i>Power Supply Recommendations</i> section, <i>Layout</i> section, <i>Device and Documentation Support</i> section, and <i>Mechanical, Packaging, and Orderable Information</i> section.	1
• Removed <i>Ordering Information</i> table, see POA at the end of the data sheet.	1
• Added Military Disclaimer to <i>Features</i>	1

5 Pin Configuration and Functions

**J, W, DB, DW N, NS, or PW Package
CDIP, CFP, SSOP, SOIC, SO, PDIP, or TSSOP
Top View**

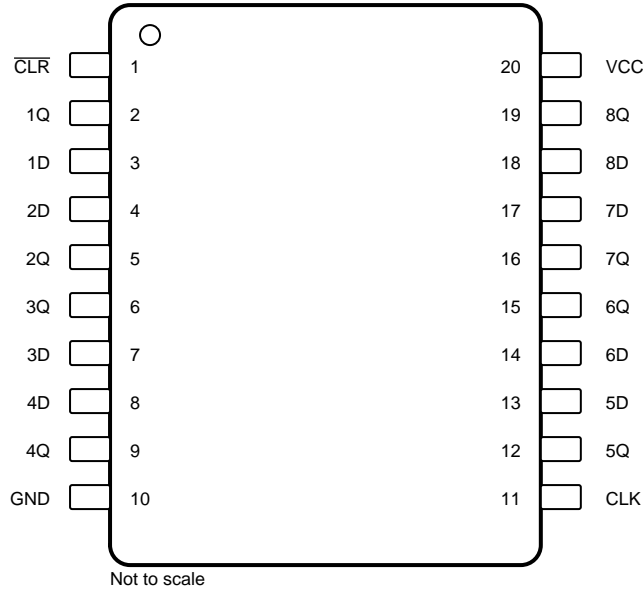

**FK Package
20-Pin LCCC
Top View**

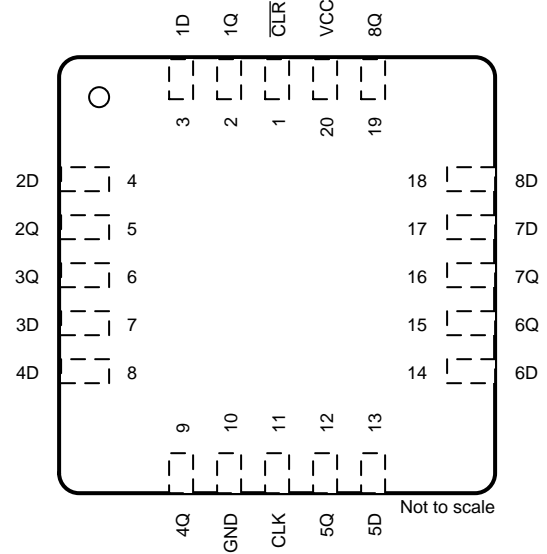

Pin Functions

PIN		I/O	DESCRIPTION
NO.	NAME		
1	$\overline{\text{CLR}}$	I	Active low clear input
2	1Q	O	Output 1
3	1D	I	Input 1
4	2D	I	Input 2
5	2Q	O	Output 2
6	3Q	O	Output 3
7	3D	I	Input 3
8	4D	I	Input 4
9	4Q	O	Output 4
10	GND	—	Ground
11	CLK	I	Clock input
12	5Q	O	Output 5
13	5D	I	Input 5
14	6D	I	Input 6
15	6Q	O	Output 6
16	7Q	O	Output 7
17	7D	I	Input 7
18	8D	I	Input 8
19	8Q	O	Output 8
20	V _{CC}	—	Power

6 Specifications

6.1 Absolute Maximum Ratings

 over operating free-air temperature range (unless otherwise noted)⁽¹⁾

			MIN	MAX	UNIT
V_{CC}	Supply voltage		-0.5	7	V
I_{IK}	Input clamp current ⁽²⁾	$V_I < 0$ or $V_I > V_{CC}$		±20	mA
I_{OK}	Output clamp current ⁽²⁾	$V_O < 0$ or $V_O > V_{CC}$		±20	mA
I_O	Continuous output current	$V_O = 0$ to V_{CC}		±25	mA
	Continuous current through V_{CC} or GND			±50	mA
T_J	Junction temperature			150	°C
T_{stg}	Storage temperature		-65	150	°C

- (1) Stresses beyond those listed under *Absolute Maximum Ratings* may cause permanent damage to the device. These are stress ratings only, and functional operation of the device at these or any other conditions beyond those indicated under *Recommended Operating Conditions* is not implied. Exposure to absolute-maximum-rated conditions for extended periods may affect device reliability.
- (2) The input and output voltage ratings may be exceeded if the input and output current ratings are observed.

6.2 ESD Ratings – SN74HC273

			VALUE	UNIT
$V_{(ESD)}$	Electrostatic discharge	Human-body model (HBM), per ANSI/ESDA/JEDEC JS-001 ⁽¹⁾	±2000	V
		Charged-device model (CDM), per JEDEC specification JESD22-C101 ⁽²⁾	±500	

- (1) JEDEC document JEP155 states that 500-V HBM allows safe manufacturing with a standard ESD control process. Manufacturing with less than 500-V HBM is possible with the necessary precautions.
- (2) JEDEC document JEP157 states that 250-V CDM allows safe manufacturing with a standard ESD control process. Manufacturing with less than 250-V CDM is possible with the necessary precautions.

6.3 Recommended Operating Conditions

 over operating free-air temperature range (unless otherwise noted)⁽¹⁾

			MIN	NOM	MAX	UNIT
V_{CC}	Supply voltage		2	5	6	V
V_{IH}	High-level input voltage	$V_{CC} = 2$ V	1.5			V
		$V_{CC} = 4.5$ V	3.15			
		$V_{CC} = 6$ V	4.2			
V_{IL}	Low-level input voltage	$V_{CC} = 2$ V			0.5	V
		$V_{CC} = 4.5$ V			1.35	
		$V_{CC} = 6$ V			1.8	
V_I	Input voltage		0		V_{CC}	V
V_O	Output voltage		0		V_{CC}	V
$\Delta t/\Delta v$	Input transition rise and fall time	$V_{CC} = 2$ V			1000	ns
		$V_{CC} = 4.5$ V			500	
		$V_{CC} = 6$ V			400	
T_A	Operating free-air temperature	SN54HC273	-55		125	°C
		SN74HC273	-40		85	

- (1) All unused inputs of the device must be held at V_{CC} or GND to ensure proper device operation. Refer to the TI application report, [Implications of Slow or Floating CMOS Inputs](#).

6.4 Thermal Information

THERMAL METRIC ⁽¹⁾		SN74HC273					UNIT
		DB (SSOP)	DW (SOIC)	N (PDIP)	NS (SO)	PW (TSSOP)	
		20 PINS	20 PINS	20 PINS	20 PINS	20 PINS	
$R_{\theta JA}$	Junction-to-ambient thermal resistance ⁽²⁾	90.3	77.4	45.1	72.6	98.3	°C/W
$R_{\theta JC(top)}$	Junction-to-case (top) thermal resistance	51.7	42.8	31.1	38.9	33.3	°C/W
$R_{\theta JB}$	Junction-to-board thermal resistance	45.5	45.2	26	40.1	49.3	°C/W
Ψ_{JT}	Junction-to-top characterization parameter	17.7	16.7	16.6	15.7	2	°C/W
Ψ_{JB}	Junction-to-board characterization parameter	45.1	44.7	25.9	39.7	48.7	°C/W

(1) For more information about traditional and new thermal metrics, see [Semiconductor and IC Package Thermal Metrics](#).

(2) The package thermal impedance is calculated in accordance with JESD 51-7.

6.5 Electrical Characteristics

$T_A = 25^\circ\text{C}$ (unless otherwise noted)

PARAMETER	TEST CONDITIONS		MIN	TYP	MAX	UNIT
V_{OH}	$V_i = V_{IH}$ or V_{IL}	$I_{OH} = -20 \mu\text{A}$	$V_{CC} = 2 \text{ V}$	1.9	1.998	V
			$V_{CC} = 4.5 \text{ V}$	4.4	4.499	
			$V_{CC} = 6 \text{ V}$	5.9	5.999	
		$I_{OH} = -4 \text{ mA}, V_{CC} = 4.5 \text{ V}$	3.98	4.3		
		$I_{OH} = -5.2 \text{ mA}, V_{CC} = 6 \text{ V}$	5.48	5.8		
V_{OL}	$V_i = V_{IH}$ or V_{IL}	$I_{OL} = 20 \mu\text{A}$	$V_{CC} = 2 \text{ V}$	0.002	0.1	V
			$V_{CC} = 4.5 \text{ V}$	0.001	0.1	
			$V_{CC} = 6 \text{ V}$	0.001	0.1	
		$I_{OL} = 4 \text{ mA}, V_{CC} = 4.5 \text{ V}$	0.17	0.26		
		$I_{OL} = 5.2 \text{ mA}, V_{CC} = 6 \text{ V}$	0.15	0.26		
I_i	$V_i = V_{CC}$ or 0, $V_{CC} = 6 \text{ V}$			± 0.1	± 100	nA
I_{CC}	$V_i = V_{CC}$ or 0, $I_O = 0$, $V_{CC} = 6 \text{ V}$				8	μA
C_i	$V_{CC} = 2 \text{ V}$ to 6 V			3	10	pF

6.6 Electrical Characteristics – SN54HC273

over recommended operating free-air temperature range (unless otherwise noted)

PARAMETER	TEST CONDITIONS		MIN	TYP	MAX	UNIT
V_{OH}	$V_i = V_{IH}$ or V_{IL}	$I_{OH} = -20 \mu\text{A}$	$V_{CC} = 2 \text{ V}$	1.9		V
			$V_{CC} = 4.5 \text{ V}$	4.4		
			$V_{CC} = 6 \text{ V}$	5.9		
		$I_{OH} = -4 \text{ mA}, V_{CC} = 4.5 \text{ V}$	3.7			
		$I_{OH} = -5.2 \text{ mA}, V_{CC} = 6 \text{ V}$	5.2			
V_{OL}	$V_i = V_{IH}$ or V_{IL}	$I_{OL} = 20 \mu\text{A}$	$V_{CC} = 2 \text{ V}$		0.1	V
			$V_{CC} = 4.5 \text{ V}$		0.1	
			$V_{CC} = 6 \text{ V}$		0.1	
		$I_{OL} = 4 \text{ mA}, V_{CC} = 4.5 \text{ V}$		0.4		
		$I_{OL} = 5.2 \text{ mA}, V_{CC} = 6 \text{ V}$		0.4		
I_i	$V_i = V_{CC}$ or 0, $V_{CC} = 6 \text{ V}$				± 1000	nA
I_{CC}	$V_i = V_{CC}$ or 0, $I_O = 0$, $V_{CC} = 6 \text{ V}$				160	μA
C_i	$V_{CC} = 2 \text{ V}$ to 6 V				10	pF

6.7 Electrical Characteristics – SN74HC273

over recommended operating free-air temperature range (unless otherwise noted)

PARAMETER	TEST CONDITIONS		MIN	TYP	MAX	UNIT
V_{OH}	$V_I = V_{IH}$ or V_{IL}	$I_{OH} = -20 \mu A$	$V_{CC} = 2 V$		1.9	V
			$V_{CC} = 4.5 V$		4.4	
			$V_{CC} = 6 V$		5.9	
		$I_{OH} = -4 mA, V_{CC} = 4.5 V$			3.84	
		$I_{OH} = -5.2 mA, V_{CC} = 6 V$		5.34		
V_{OL}	$V_I = V_{IH}$ or V_{IL}	$I_{OL} = 20 \mu A$	$V_{CC} = 2 V$		0.1	V
			$V_{CC} = 4.5 V$		0.1	
			$V_{CC} = 6 V$		0.1	
		$I_{OL} = 4 mA, V_{CC} = 4.5 V$			0.33	
		$I_{OL} = 5.2 mA, V_{CC} = 6 V$		0.33		
I_I	$V_I = V_{CC}$ or 0, $V_{CC} = 6 V$				± 1000	nA
I_{CC}	$V_I = V_{CC}$ or 0, $I_O = 0, V_{CC} = 6 V$				80	μA
C_i	$V_{CC} = 2 V$ to $6 V$				10	pF

6.8 Timing Requirements

 $T_A = 25^\circ C$ (unless otherwise noted)

			MIN	MAX	UNIT
f_{clock}	Clock frequency	$V_{CC} = 2 V$		5	MHz
		$V_{CC} = 4.5 V$		27	
		$V_{CC} = 6 V$		32	
t_w	Pulse duration	\overline{CLR} low	$V_{CC} = 2 V$	80	ns
			$V_{CC} = 4.5 V$	16	
			$V_{CC} = 6 V$	14	
	CLK high or low	$V_{CC} = 2 V$	80		
		$V_{CC} = 4.5 V$	16		
		$V_{CC} = 6 V$	14		
t_{su}	Setup time before CLK \uparrow	Data	$V_{CC} = 2 V$	100	ns
			$V_{CC} = 4.5 V$	20	
			$V_{CC} = 6 V$	17	
	\overline{CLR} inactive	$V_{CC} = 2 V$	100		
		$V_{CC} = 4.5 V$	20		
		$V_{CC} = 6 V$	17		
t_h	Hold time, data after CLK \uparrow	$V_{CC} = 2 V$	0	ns	
		$V_{CC} = 4.5 V$	0		
		$V_{CC} = 6 V$	0		

6.9 Timing Requirements – SN54HC273

over recommended operating free-air temperature range (unless otherwise noted)

		MIN	MAX	UNIT
f_{clock}	Clock frequency	$V_{\text{CC}} = 2 \text{ V}$	4	MHz
		$V_{\text{CC}} = 4.5 \text{ V}$	18	
		$V_{\text{CC}} = 6 \text{ V}$	21	
t_w	$\overline{\text{CLR}}$ low	$V_{\text{CC}} = 2 \text{ V}$	120	ns
		$V_{\text{CC}} = 4.5 \text{ V}$	24	
		$V_{\text{CC}} = 6 \text{ V}$	20	
	CLK high or low	$V_{\text{CC}} = 2 \text{ V}$	120	
		$V_{\text{CC}} = 4.5 \text{ V}$	24	
		$V_{\text{CC}} = 6 \text{ V}$	20	
t_{su}	Data	$V_{\text{CC}} = 2 \text{ V}$	150	ns
		$V_{\text{CC}} = 4.5 \text{ V}$	30	
		$V_{\text{CC}} = 6 \text{ V}$	25	
	$\overline{\text{CLR}}$ inactive	$V_{\text{CC}} = 2 \text{ V}$	150	
		$V_{\text{CC}} = 4.5 \text{ V}$	30	
		$V_{\text{CC}} = 6 \text{ V}$	25	
t_h	Hold time, data after CLK \uparrow	$V_{\text{CC}} = 2 \text{ V}$	0	ns
		$V_{\text{CC}} = 4.5 \text{ V}$	0	
		$V_{\text{CC}} = 6 \text{ V}$	0	

6.10 Timing Requirements – SN74HC273

over recommended operating free-air temperature range (unless otherwise noted)

		MIN	MAX	UNIT
f_{clock}	Clock frequency	$V_{\text{CC}} = 2 \text{ V}$	4	MHz
		$V_{\text{CC}} = 4.5 \text{ V}$	21	
		$V_{\text{CC}} = 6 \text{ V}$	25	
t_w	$\overline{\text{CLR}}$ low	$V_{\text{CC}} = 2 \text{ V}$	100	ns
		$V_{\text{CC}} = 4.5 \text{ V}$	20	
		$V_{\text{CC}} = 6 \text{ V}$	17	
	CLK high or low	$V_{\text{CC}} = 2 \text{ V}$	100	
		$V_{\text{CC}} = 4.5 \text{ V}$	20	
		$V_{\text{CC}} = 6 \text{ V}$	17	
t_{su}	Data	$V_{\text{CC}} = 2 \text{ V}$	125	ns
		$V_{\text{CC}} = 4.5 \text{ V}$	25	
		$V_{\text{CC}} = 6 \text{ V}$	21	
	$\overline{\text{CLR}}$ inactive	$V_{\text{CC}} = 2 \text{ V}$	125	
		$V_{\text{CC}} = 4.5 \text{ V}$	25	
		$V_{\text{CC}} = 6 \text{ V}$	21	
t_h	Hold time, data after CLK \uparrow	$V_{\text{CC}} = 2 \text{ V}$	0	ns
		$V_{\text{CC}} = 4.5 \text{ V}$	0	
		$V_{\text{CC}} = 6 \text{ V}$	0	

6.11 Switching Characteristics

 $T_A = 25^\circ\text{C}$ and $C_L = 50\text{ pF}$ (unless otherwise noted; see [Figure 2](#))

PARAMETER	TEST CONDITIONS	MIN	TYP	MAX	UNIT	
f_{max}		$V_{\text{CC}} = 2\text{ V}$	5	11	MHz	
		$V_{\text{CC}} = 4.5\text{ V}$	27	50		
		$V_{\text{CC}} = 6\text{ V}$	32	60		
t_{PHL}	From $\overline{\text{CLR}}$ (input) to any (output)	$V_{\text{CC}} = 2\text{ V}$		55	160	ns
		$V_{\text{CC}} = 4.5\text{ V}$		15	32	
		$V_{\text{CC}} = 6\text{ V}$		12	27	
t_{pd}	From CLK (input) to any (output)	$V_{\text{CC}} = 2\text{ V}$		56	160	ns
		$V_{\text{CC}} = 4.5\text{ V}$		15	32	
		$V_{\text{CC}} = 6\text{ V}$		13	27	
t_t	To any (output)	$V_{\text{CC}} = 2\text{ V}$		38	75	ns
		$V_{\text{CC}} = 4.5\text{ V}$		8	15	
		$V_{\text{CC}} = 6\text{ V}$		6	13	

6.12 Switching Characteristics – SN54HC273

 over recommended operating free-air temperature range, $C_L = 50\text{ pF}$ (unless otherwise noted; see [Figure 2](#))

PARAMETER	TEST CONDITIONS	MIN	MAX	UNIT	
f_{max}		$V_{\text{CC}} = 2\text{ V}$	4	MHz	
		$V_{\text{CC}} = 4.5\text{ V}$	18		
		$V_{\text{CC}} = 6\text{ V}$	21		
t_{PHL}	From $\overline{\text{CLR}}$ (input) to any (output)	$V_{\text{CC}} = 2\text{ V}$		240	ns
		$V_{\text{CC}} = 4.5\text{ V}$		48	
		$V_{\text{CC}} = 6\text{ V}$		41	
t_{pd}	From CLK (input) to any (output)	$V_{\text{CC}} = 2\text{ V}$		240	ns
		$V_{\text{CC}} = 4.5\text{ V}$		48	
		$V_{\text{CC}} = 6\text{ V}$		41	
t_t	To any (output)	$V_{\text{CC}} = 2\text{ V}$		110	ns
		$V_{\text{CC}} = 4.5\text{ V}$		22	
		$V_{\text{CC}} = 6\text{ V}$		19	

6.13 Switching Characteristics – SN74HC273

 over recommended operating free-air temperature range, $C_L = 50\text{ pF}$ (unless otherwise noted; see [Figure 2](#))

PARAMETER	TEST CONDITIONS	MIN	MAX	UNIT	
f_{max}		$V_{\text{CC}} = 2\text{ V}$	4	MHz	
		$V_{\text{CC}} = 4.5\text{ V}$	21		
		$V_{\text{CC}} = 6\text{ V}$	25		
t_{PHL}	From $\overline{\text{CLR}}$ (input) to any (output)	$V_{\text{CC}} = 2\text{ V}$		200	ns
		$V_{\text{CC}} = 4.5\text{ V}$		40	
		$V_{\text{CC}} = 6\text{ V}$		34	
t_{pd}	From CLK (input) to any (output)	$V_{\text{CC}} = 2\text{ V}$		200	ns
		$V_{\text{CC}} = 4.5\text{ V}$		40	
		$V_{\text{CC}} = 6\text{ V}$		34	
t_t	To any (output)	$V_{\text{CC}} = 2\text{ V}$		95	ns
		$V_{\text{CC}} = 4.5\text{ V}$		19	
		$V_{\text{CC}} = 6\text{ V}$		16	

6.14 Operating Characteristics

T_A = 25°C

PARAMETER	TEST CONDITIONS	TYP	UNIT
C _{pd} Power dissipation capacitance per flip-flop	No load	35	pF

6.15 Typical Characteristics

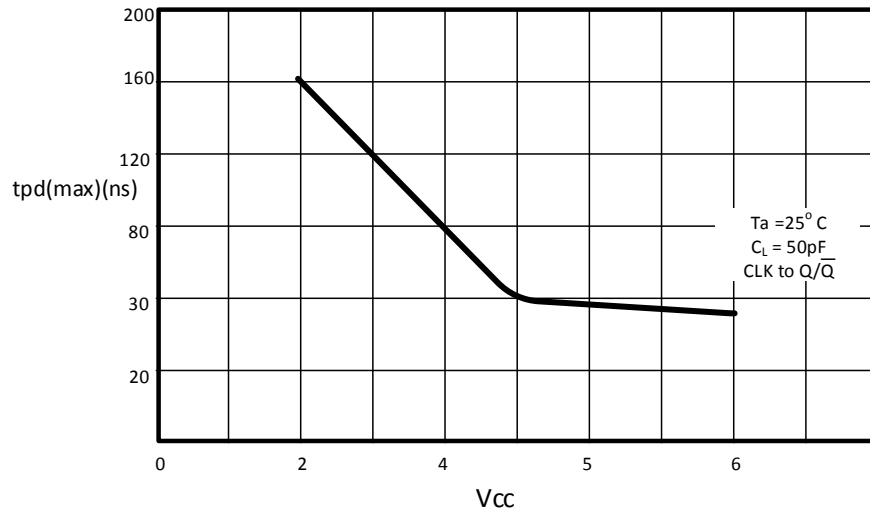

7 Parameter Measurement Information

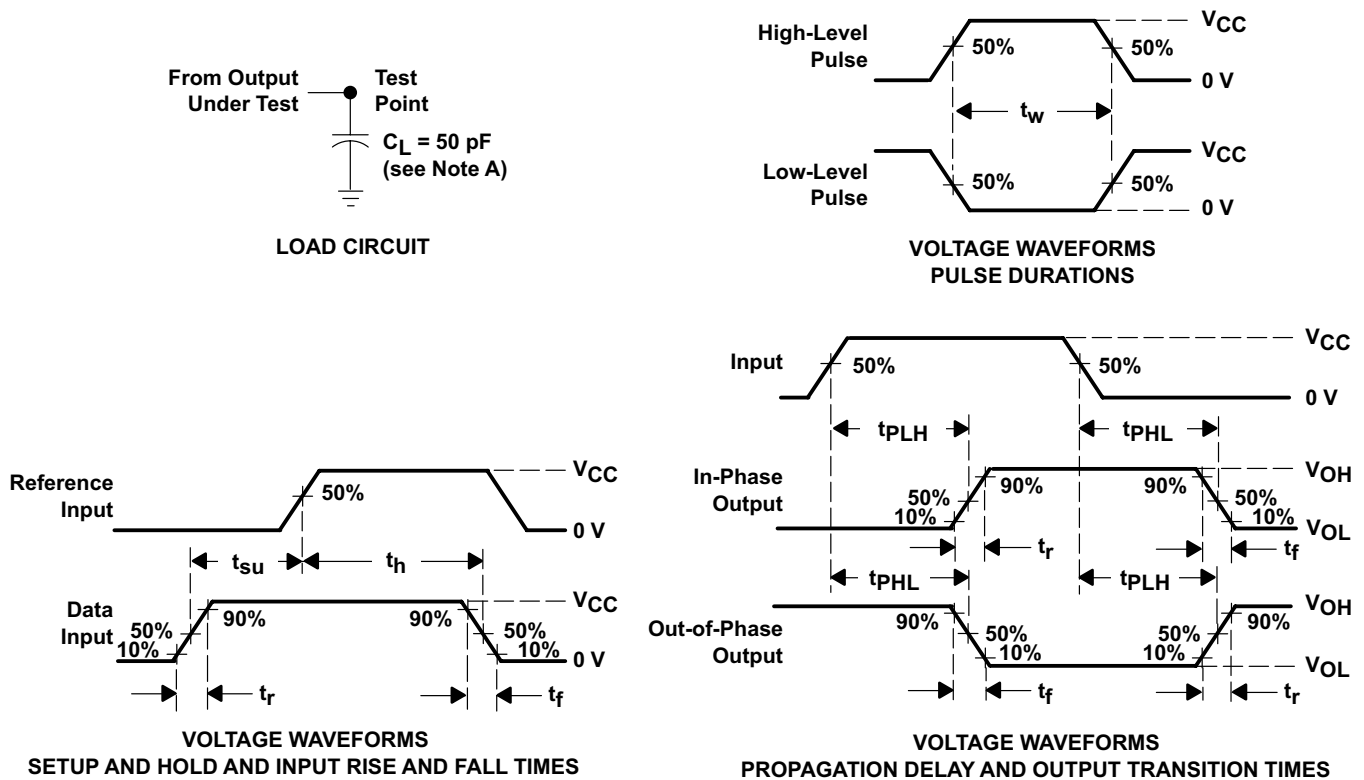

- NOTES:
- C_L includes probe and test-fixture capacitance.
 - Phase relationships between waveforms were chosen arbitrarily. All input pulses are supplied by generators having the following characteristics: $PRR \leq 1 \text{ MHz}$, $Z_O = 50 \Omega$, $t_r = 6 \text{ ns}$, $t_f = 6 \text{ ns}$.
 - For clock inputs, f_{max} is measured when the input duty cycle is 50%.
 - The outputs are measured one at a time with one input transition per measurement.
 - t_{PLH} and t_{PHL} are the same as t_{pd} .

Figure 2. Load Circuit and Voltage Waveforms

8 Detailed Description

8.1 Overview

The SNx4HC273 contains eight flip-flops with single-rail outputs with individual data input to each flip-flop. The outputs can drive up to 10 LSTTL loads. The device has direct active low clear input.

8.2 Functional Block Diagram

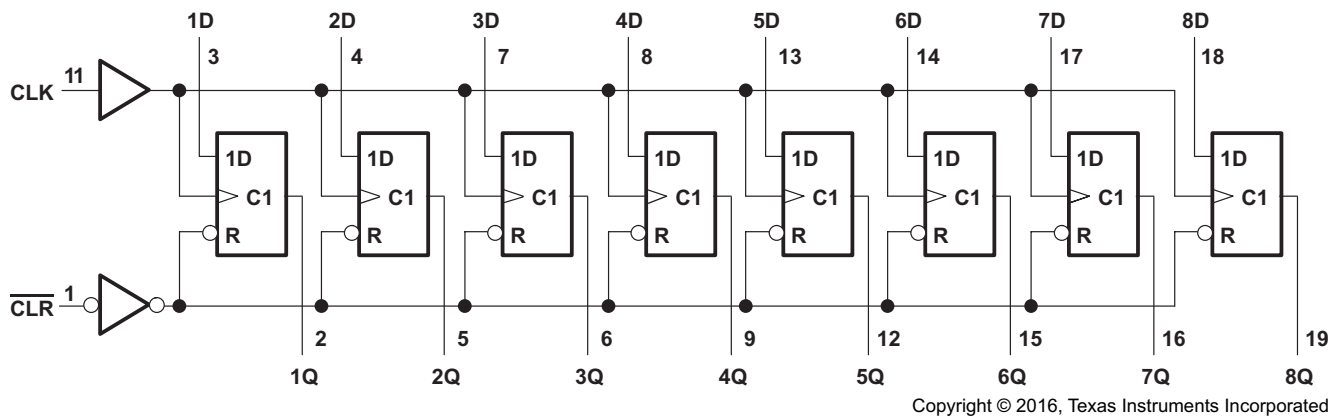

8.3 Feature Description

The SNx4HC273 has low power consumption with a maximum I_{CC} of 80 μ A.

The typical t_{pd} for the SNx4HC273 is 12 ns and the output drive is ± 4 mA at 5 V.

The SNx4HC273 also has very low input current, with the maximum set at 1 μ A.

8.4 Device Functional Modes

Table 1 lists the functional modes of the SNx4HC273.

Table 1. Function Table (Each Flip-Flop)

INPUTS			OUTPUT Q
$\overline{\text{CLR}}$	CLK	D	
L	X	X	L
H	\uparrow	H	H
H	\uparrow	L	L
H	L	X	Q_0

9 Application and Implementation

NOTE

Information in the following applications sections is not part of the TI component specification, and TI does not warrant its accuracy or completeness. TI's customers are responsible for determining suitability of components for their purposes. Customers should validate and test their design implementation to confirm system functionality.

9.1 Application Information

The SNx4HC273 is octal D Flip flop with active low clear input. It has low input current and low power consumption. The D flip-flop can be used as a Toggle flip flop using an XOR gate at the input. The output toggles from the previous state whenever the T input is high.

9.2 Typical Application

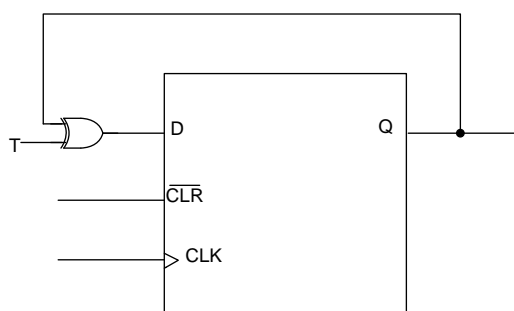

Copyright © 2016, Texas Instruments Incorporated

9.2.1 Design Requirements

This SNx4Hc273 device uses CMOS technology and has balanced output drive.

9.2.2 Detailed Design Procedure

1. Recommended input conditions:
 - Rise time and fall time specifications: see $(\Delta t/\Delta V)$ in [Recommended Operating Conditions](#).
 - Specified high and low levels: see $(V_{IH}$ and $V_{IL})$ in [Recommended Operating Conditions](#).
 - Inputs are not overvoltage tolerant and must not be above any valid V_{CC} as per [Recommended Operating Conditions](#).
2. Absolute maximum output conditions:
 - Continuous output currents must not exceed $(I_O \text{ max})$ per output and must not exceed total current (continuous current through V_{CC} or GND) for the part. These limits are located in the [Absolute Maximum Ratings](#).
 - Outputs must not be pulled above V_{CC} .

Typical Application (continued)

9.2.3 Application Curve

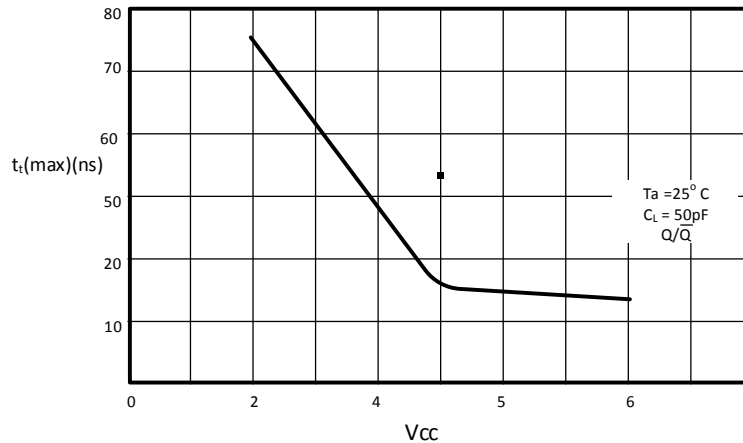

Figure 3. Max Transition Time vs V_{CC}

10 Power Supply Recommendations

The power supply can be any voltage between the minimum and maximum supply voltage rating located in [Recommended Operating Conditions](#).

Each V_{CC} pin must have a good bypass capacitor to prevent power disturbance. For devices with a single supply, TI recommends a 0.1- μ F capacitor. If there are multiple V_{CC} pins, TI recommends a 0.01- μ F or 0.022- μ F capacitor for each power pin. It is ok to parallel multiple bypass capacitors to reject different frequencies of noise. 0.1- μ F and 1- μ F capacitors are commonly used in parallel. The bypass capacitor must be installed as close to the power pin as possible for best results.

11 Layout

11.1 Layout Guidelines

When using multiple bit logic devices inputs must not ever float. In many cases, functions or parts of functions of digital logic devices are unused; for example, when only two inputs of a triple-input AND gate are used or only 3 of the 4 buffer gates are used. Such input pins must not be left unconnected because the undefined voltages at the outside connections result in undefined operational states. Specified below are the rules that must be observed under all circumstances:

- All unused inputs of digital logic devices must be connected to a high or low bias to prevent them from floating.
- The logic level that must be applied to any particular unused input depends on the function of the device.
- Generally they are tied to GND or V_{CC} whichever make more sense or is more convenient.

11.2 Layout Example

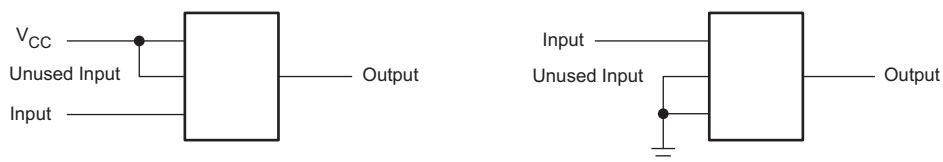

Figure 4. SNx4HC273 Layout

12 Device and Documentation Support

12.1 Documentation Support

12.1.1 Related Documentation

For related documentation, see the following:

[Implications of Slow or Floating CMOS Inputs](#)

12.2 Related Links

The table below lists quick access links. Categories include technical documents, support and community resources, tools and software, and quick access to sample or buy.

Table 2. Related Links

PARTS	PRODUCT FOLDER	SAMPLE & BUY	TECHNICAL DOCUMENTS	TOOLS & SOFTWARE	SUPPORT & COMMUNITY
SN54HC273	Click here	Click here	Click here	Click here	Click here
SN74HC273	Click here	Click here	Click here	Click here	Click here

12.3 Receiving Notification of Documentation Updates

To receive notification of documentation updates, navigate to the device product folder on ti.com. In the upper right corner, click on *Alert me* to register and receive a weekly digest of any product information that has changed. For change details, review the revision history included in any revised document.

12.4 Community Resources

The following links connect to TI community resources. Linked contents are provided "AS IS" by the respective contributors. They do not constitute TI specifications and do not necessarily reflect TI's views; see TI's [Terms of Use](#).

TI E2E™ Online Community *TI's Engineer-to-Engineer (E2E) Community*. Created to foster collaboration among engineers. At e2e.ti.com, you can ask questions, share knowledge, explore ideas and help solve problems with fellow engineers.

Design Support *TI's Design Support* Quickly find helpful E2E forums along with design support tools and contact information for technical support.

12.5 Trademarks

E2E is a trademark of Texas Instruments.

All other trademarks are the property of their respective owners.

12.6 Electrostatic Discharge Caution



These devices have limited built-in ESD protection. The leads should be shorted together or the device placed in conductive foam during storage or handling to prevent electrostatic damage to the MOS gates.

12.7 Glossary

[SLYZ022](#) — *TI Glossary*.

This glossary lists and explains terms, acronyms, and definitions.

13 Mechanical, Packaging, and Orderable Information

The following pages include mechanical packaging and orderable information. This information is the most current data available for the designated devices. This data is subject to change without notice and revision of this document. For browser based versions of this data sheet, refer to the left hand navigation.

PACKAGING INFORMATION

Orderable Device	Status (1)	Package Type	Package Drawing	Pins	Package Qty	Eco Plan (2)	Lead/Ball Finish (6)	MSL Peak Temp (3)	Op Temp (°C)	Device Marking (4/5)	Samples
5962-8409901VRA	ACTIVE	CDIP	J	20	1	TBD	A42	N / A for Pkg Type		5962-8409901VR A SNV54HC273J	Samples
5962-8409901VSA	ACTIVE	CFP	W	20	25	TBD	A42	N / A for Pkg Type		5962-8409901VS A SNV54HC273W	Samples
84099012A	ACTIVE	LCCC	FK	20	1	TBD	POST-PLATE	N / A for Pkg Type	-55 to 125	84099012A SNJ54HC 273FK	Samples
8409901RA	ACTIVE	CDIP	J	20	1	TBD	A42	N / A for Pkg Type	-55 to 125	8409901RA SNJ54HC273J	Samples
8409901SA	ACTIVE	CFP	W	20	1	TBD	A42	N / A for Pkg Type	-55 to 125	8409901SA SNJ54HC273W	Samples
JM38510/65601BRA	ACTIVE	CDIP	J	20	1	TBD	A42	N / A for Pkg Type	-55 to 125	JM38510/ 65601BRA	Samples
JM38510/65601BSA	ACTIVE	CFP	W	20	1	TBD	A42	N / A for Pkg Type	-55 to 125	JM38510/ 65601BSA	Samples
M38510/65601BRA	ACTIVE	CDIP	J	20	1	TBD	A42	N / A for Pkg Type	-55 to 125	JM38510/ 65601BRA	Samples
M38510/65601BSA	ACTIVE	CFP	W	20	1	TBD	A42	N / A for Pkg Type	-55 to 125	JM38510/ 65601BSA	Samples
SN54HC273J	ACTIVE	CDIP	J	20	1	TBD	A42	N / A for Pkg Type	-55 to 125	SN54HC273J	Samples
SN74HC273DBLE	OBSOLETE	SSOP	DB	20		TBD	Call TI	Call TI	-40 to 85		
SN74HC273DBR	ACTIVE	SSOP	DB	20	2000	Green (RoHS & no Sb/Br)	CU NIPDAU	Level-1-260C-UNLIM	-40 to 85	HC273	Samples
SN74HC273DBRG4	ACTIVE	SSOP	DB	20	2000	Green (RoHS & no Sb/Br)	CU NIPDAU	Level-1-260C-UNLIM	-40 to 85	HC273	Samples
SN74HC273DW	ACTIVE	SOIC	DW	20	25	Green (RoHS & no Sb/Br)	CU NIPDAU	Level-1-260C-UNLIM	-40 to 85	HC273	Samples
SN74HC273DWE4	ACTIVE	SOIC	DW	20	25	Green (RoHS & no Sb/Br)	CU NIPDAU	Level-1-260C-UNLIM	-40 to 85	HC273	Samples
SN74HC273DWG4	ACTIVE	SOIC	DW	20	25	Green (RoHS & no Sb/Br)	CU NIPDAU	Level-1-260C-UNLIM	-40 to 85	HC273	Samples

Orderable Device	Status (1)	Package Type	Package Drawing	Pins	Package Qty	Eco Plan (2)	Lead/Ball Finish (6)	MSL Peak Temp (3)	Op Temp (°C)	Device Marking (4/5)	Samples
SN74HC273DWR	ACTIVE	SOIC	DW	20	2000	Green (RoHS & no Sb/Br)	CU NIPDAU CU SN	Level-1-260C-UNLIM	-40 to 85	HC273	Samples
SN74HC273DWRE4	ACTIVE	SOIC	DW	20	2000	Green (RoHS & no Sb/Br)	CU NIPDAU	Level-1-260C-UNLIM	-40 to 85	HC273	Samples
SN74HC273DWRG4	ACTIVE	SOIC	DW	20	2000	Green (RoHS & no Sb/Br)	CU NIPDAU	Level-1-260C-UNLIM	-40 to 85	HC273	Samples
SN74HC273N	ACTIVE	PDIP	N	20	20	Pb-Free (RoHS)	CU NIPDAU	N / A for Pkg Type	-40 to 85	SN74HC273N	Samples
SN74HC273N3	OBSOLETE	PDIP	N	20		TBD	Call TI	Call TI	-40 to 85		
SN74HC273NE4	ACTIVE	PDIP	N	20	20	Pb-Free (RoHS)	CU NIPDAU	N / A for Pkg Type	-40 to 85	SN74HC273N	Samples
SN74HC273NSR	ACTIVE	SO	NS	20	2000	Green (RoHS & no Sb/Br)	CU NIPDAU	Level-1-260C-UNLIM	-40 to 85	HC273	Samples
SN74HC273NSRG4	ACTIVE	SO	NS	20	2000	Green (RoHS & no Sb/Br)	CU NIPDAU	Level-1-260C-UNLIM	-40 to 85	HC273	Samples
SN74HC273PW	ACTIVE	TSSOP	PW	20	70	Green (RoHS & no Sb/Br)	CU NIPDAU	Level-1-260C-UNLIM	-40 to 85	HC273	Samples
SN74HC273PWG4	ACTIVE	TSSOP	PW	20	70	Green (RoHS & no Sb/Br)	CU NIPDAU	Level-1-260C-UNLIM	-40 to 85	HC273	Samples
SN74HC273PWLE	OBSOLETE	TSSOP	PW	20		TBD	Call TI	Call TI	-40 to 85		
SN74HC273PWR	ACTIVE	TSSOP	PW	20	2000	Green (RoHS & no Sb/Br)	CU NIPDAU	Level-1-260C-UNLIM	-40 to 85	HC273	Samples
SN74HC273PWRG4	ACTIVE	TSSOP	PW	20	2000	Green (RoHS & no Sb/Br)	CU NIPDAU	Level-1-260C-UNLIM	-40 to 85	HC273	Samples
SN74HC273PWT	ACTIVE	TSSOP	PW	20	250	Green (RoHS & no Sb/Br)	CU NIPDAU	Level-1-260C-UNLIM	-40 to 85	HC273	Samples
SNJ54HC273FK	ACTIVE	LCCC	FK	20	1	TBD	POST-PLATE	N / A for Pkg Type	-55 to 125	84099012A SNJ54HC 273FK	Samples
SNJ54HC273J	ACTIVE	CDIP	J	20	1	TBD	A42	N / A for Pkg Type	-55 to 125	8409901RA SNJ54HC273J	Samples
SNJ54HC273W	ACTIVE	CFP	W	20	1	TBD	A42	N / A for Pkg Type	-55 to 125	8409901SA SNJ54HC273W	Samples

(1) The marketing status values are defined as follows:

ACTIVE: Product device recommended for new designs.

LIFEBUY: TI has announced that the device will be discontinued, and a lifetime-buy period is in effect.

NRND: Not recommended for new designs. Device is in production to support existing customers, but TI does not recommend using this part in a new design.

PREVIEW: Device has been announced but is not in production. Samples may or may not be available.

OBSOLETE: TI has discontinued the production of the device.

⁽²⁾ Eco Plan - The planned eco-friendly classification: Pb-Free (RoHS), Pb-Free (RoHS Exempt), or Green (RoHS & no Sb/Br) - please check <http://www.ti.com/productcontent> for the latest availability information and additional product content details.

TBD: The Pb-Free/Green conversion plan has not been defined.

Pb-Free (RoHS): TI's terms "Lead-Free" or "Pb-Free" mean semiconductor products that are compatible with the current RoHS requirements for all 6 substances, including the requirement that lead not exceed 0.1% by weight in homogeneous materials. Where designed to be soldered at high temperatures, TI Pb-Free products are suitable for use in specified lead-free processes.

Pb-Free (RoHS Exempt): This component has a RoHS exemption for either 1) lead-based flip-chip solder bumps used between the die and package, or 2) lead-based die adhesive used between the die and leadframe. The component is otherwise considered Pb-Free (RoHS compatible) as defined above.

Green (RoHS & no Sb/Br): TI defines "Green" to mean Pb-Free (RoHS compatible), and free of Bromine (Br) and Antimony (Sb) based flame retardants (Br or Sb do not exceed 0.1% by weight in homogeneous material)

⁽³⁾ MSL, Peak Temp. - The Moisture Sensitivity Level rating according to the JEDEC industry standard classifications, and peak solder temperature.

⁽⁴⁾ There may be additional marking, which relates to the logo, the lot trace code information, or the environmental category on the device.

⁽⁵⁾ Multiple Device Markings will be inside parentheses. Only one Device Marking contained in parentheses and separated by a "~" will appear on a device. If a line is indented then it is a continuation of the previous line and the two combined represent the entire Device Marking for that device.

⁽⁶⁾ Lead/Ball Finish - Orderable Devices may have multiple material finish options. Finish options are separated by a vertical ruled line. Lead/Ball Finish values may wrap to two lines if the finish value exceeds the maximum column width.

Important Information and Disclaimer:The information provided on this page represents TI's knowledge and belief as of the date that it is provided. TI bases its knowledge and belief on information provided by third parties, and makes no representation or warranty as to the accuracy of such information. Efforts are underway to better integrate information from third parties. TI has taken and continues to take reasonable steps to provide representative and accurate information but may not have conducted destructive testing or chemical analysis on incoming materials and chemicals. TI and TI suppliers consider certain information to be proprietary, and thus CAS numbers and other limited information may not be available for release.

In no event shall TI's liability arising out of such information exceed the total purchase price of the TI part(s) at issue in this document sold by TI to Customer on an annual basis.

OTHER QUALIFIED VERSIONS OF SN54HC273, SN54HC273-SP, SN74HC273 :

● Catalog: [SN74HC273](#), [SN54HC273](#)

● Automotive: [SN74HC273-Q1](#), [SN74HC273-Q1](#)

● Military: [SN54HC273](#)

- Space: [SN54HC273-SP](#)

NOTE: Qualified Version Definitions:

- Catalog - TI's standard catalog product
- Automotive - Q100 devices qualified for high-reliability automotive applications targeting zero defects
- Military - QML certified for Military and Defense Applications
- Space - Radiation tolerant, ceramic packaging and qualified for use in Space-based application

TAPE AND REEL INFORMATION

QUADRANT ASSIGNMENTS FOR PIN 1 ORIENTATION IN TAPE

*All dimensions are nominal

Device	Package Type	Package Drawing	Pins	SPQ	Reel Diameter (mm)	Reel Width W1 (mm)	A0 (mm)	B0 (mm)	K0 (mm)	P1 (mm)	W (mm)	Pin1 Quadrant
SN74HC273DBR	SSOP	DB	20	2000	330.0	16.4	8.2	7.5	2.5	12.0	16.0	Q1
SN74HC273DWR	SOIC	DW	20	2000	330.0	24.4	10.8	13.3	2.7	12.0	24.0	Q1
SN74HC273DWRG4	SOIC	DW	20	2000	330.0	24.4	10.8	13.3	2.7	12.0	24.0	Q1
SN74HC273NSR	SO	NS	20	2000	330.0	24.4	9.0	13.0	2.4	4.0	24.0	Q1
SN74HC273PWR	TSSOP	PW	20	2000	330.0	16.4	6.95	7.1	1.6	8.0	16.0	Q1
SN74HC273PWT	TSSOP	PW	20	250	330.0	16.4	6.95	7.1	1.6	8.0	16.0	Q1

TAPE AND REEL BOX DIMENSIONS

*All dimensions are nominal

Device	Package Type	Package Drawing	Pins	SPQ	Length (mm)	Width (mm)	Height (mm)
SN74HC273DBR	SSOP	DB	20	2000	367.0	367.0	38.0
SN74HC273DWR	SOIC	DW	20	2000	600.0	144.0	84.0
SN74HC273DWRG4	SOIC	DW	20	2000	367.0	367.0	45.0
SN74HC273NSR	SO	NS	20	2000	367.0	367.0	45.0
SN74HC273PWR	TSSOP	PW	20	2000	367.0	367.0	38.0
SN74HC273PWT	TSSOP	PW	20	250	367.0	367.0	38.0

J (R-GDIP-T**)

14 LEADS SHOWN

CERAMIC DUAL IN-LINE PACKAGE



DIM \ PINS **	14	16	18	20
A	0.300 (7,62) BSC	0.300 (7,62) BSC	0.300 (7,62) BSC	0.300 (7,62) BSC
B MAX	0.785 (19,94)	.840 (21,34)	0.960 (24,38)	1.060 (26,92)
B MIN	—	—	—	—
C MAX	0.300 (7,62)	0.300 (7,62)	0.310 (7,87)	0.300 (7,62)
C MIN	0.245 (6,22)	0.245 (6,22)	0.220 (5,59)	0.245 (6,22)



4040083/F 03/03

- NOTES:
- All linear dimensions are in inches (millimeters).
 - This drawing is subject to change without notice.
 - This package is hermetically sealed with a ceramic lid using glass frit.
 - Index point is provided on cap for terminal identification only on press ceramic glass frit seal only.
 - Falls within MIL STD 1835 GDIP1-T14, GDIP1-T16, GDIP1-T18 and GDIP1-T20.

W (R-GDFP-F20)

CERAMIC DUAL FLATPACK



- NOTES:
- A. All linear dimensions are in inches (millimeters).
 - B. This drawing is subject to change without notice.
 - C. This package can be hermetically sealed with a ceramic lid using glass frit.
 - D. Index point is provided on cap for terminal identification only.
 - E. Falls within Mil-Std 1835 GDFP2-F20

FK (S-CQCC-N**)

LEADLESS CERAMIC CHIP CARRIER

28 TERMINAL SHOWN



NO. OF TERMINALS **	A		B	
	MIN	MAX	MIN	MAX
20	0.342 (8,69)	0.358 (9,09)	0.307 (7,80)	0.358 (9,09)
28	0.442 (11,23)	0.458 (11,63)	0.406 (10,31)	0.458 (11,63)
44	0.640 (16,26)	0.660 (16,76)	0.495 (12,58)	0.560 (14,22)
52	0.740 (18,78)	0.761 (19,32)	0.495 (12,58)	0.560 (14,22)
68	0.938 (23,83)	0.962 (24,43)	0.850 (21,6)	0.858 (21,8)
84	1.141 (28,99)	1.165 (29,59)	1.047 (26,6)	1.063 (27,0)



4040140/D 01/11

- NOTES:
- All linear dimensions are in inches (millimeters).
 - This drawing is subject to change without notice.
 - This package can be hermetically sealed with a metal lid.
 - Falls within JEDEC MS-004

N (R-PDIP-T**)

PLASTIC DUAL-IN-LINE PACKAGE

16 PINS SHOWN



- NOTES:
- A. All linear dimensions are in inches (millimeters).
 - B. This drawing is subject to change without notice.
 - $\triangle C$ Falls within JEDEC MS-001, except 18 and 20 pin minimum body length (Dim A).
 - $\triangle D$ The 20 pin end lead shoulder width is a vendor option, either half or full width.

DW0020A



PACKAGE OUTLINE

SOIC - 2.65 mm max height

SOIC



4220724/A 05/2016

NOTES:

1. All linear dimensions are in millimeters. Dimensions in parenthesis are for reference only. Dimensioning and tolerancing per ASME Y14.5M.
2. This drawing is subject to change without notice.
3. This dimension does not include mold flash, protrusions, or gate burrs. Mold flash, protrusions, or gate burrs shall not exceed 0.15 mm per side.
4. This dimension does not include interlead flash. Interlead flash shall not exceed 0.43 mm per side.
5. Reference JEDEC registration MS-013.

EXAMPLE BOARD LAYOUT

DW0020A

SOIC - 2.65 mm max height

SOIC



LAND PATTERN EXAMPLE
SCALE:6X



SOLDER MASK DETAILS

4220724/A 05/2016

NOTES: (continued)

- 6. Publication IPC-7351 may have alternate designs.
- 7. Solder mask tolerances between and around signal pads can vary based on board fabrication site.

EXAMPLE STENCIL DESIGN

DW0020A

SOIC - 2.65 mm max height

SOIC



SOLDER PASTE EXAMPLE
BASED ON 0.125 mm THICK STENCIL
SCALE:6X

4220724/A 05/2016

NOTES: (continued)

8. Laser cutting apertures with trapezoidal walls and rounded corners may offer better paste release. IPC-7525 may have alternate design recommendations.
9. Board assembly site may have different recommendations for stencil design.

PW (R-PDSO-G20)

PLASTIC SMALL OUTLINE



4040064-5/G 02/11

- NOTES:
- A. All linear dimensions are in millimeters. Dimensioning and tolerancing per ASME Y14.5M-1994.
 - B. This drawing is subject to change without notice.
 - C. Body length does not include mold flash, protrusions, or gate burrs. Mold flash, protrusions, or gate burrs shall not exceed 0,15 each side.
 - D. Body width does not include interlead flash. Interlead flash shall not exceed 0,25 each side.
 - E. Falls within JEDEC MO-153

PW (R-PDSO-G20)

PLASTIC SMALL OUTLINE



- NOTES:
- A. All linear dimensions are in millimeters.
 - B. This drawing is subject to change without notice.
 - C. Publication IPC-7351 is recommended for alternate design.
 - D. Laser cutting apertures with trapezoidal walls and also rounding corners will offer better paste release. Customers should contact their board assembly site for stencil design recommendations. Refer to IPC-7525 for other stencil recommendations.
 - E. Customers should contact their board fabrication site for solder mask tolerances between and around signal pads.

DB (R-PDSO-G**)

PLASTIC SMALL-OUTLINE

28 PINS SHOWN



- NOTES: A. All linear dimensions are in millimeters.
 B. This drawing is subject to change without notice.
 C. Body dimensions do not include mold flash or protrusion not to exceed 0,15.
 D. Falls within JEDEC MO-150

MECHANICAL DATA

NS (R-PDSO-G**)

PLASTIC SMALL-OUTLINE PACKAGE

14-PINS SHOWN



- NOTES:
- A. All linear dimensions are in millimeters.
 - B. This drawing is subject to change without notice.
 - C. Body dimensions do not include mold flash or protrusion, not to exceed 0,15.

IMPORTANT NOTICE

Texas Instruments Incorporated and its subsidiaries (TI) reserve the right to make corrections, enhancements, improvements and other changes to its semiconductor products and services per JESD46, latest issue, and to discontinue any product or service per JESD48, latest issue. Buyers should obtain the latest relevant information before placing orders and should verify that such information is current and complete. All semiconductor products (also referred to herein as "components") are sold subject to TI's terms and conditions of sale supplied at the time of order acknowledgment.

TI warrants performance of its components to the specifications applicable at the time of sale, in accordance with the warranty in TI's terms and conditions of sale of semiconductor products. Testing and other quality control techniques are used to the extent TI deems necessary to support this warranty. Except where mandated by applicable law, testing of all parameters of each component is not necessarily performed.

TI assumes no liability for applications assistance or the design of Buyers' products. Buyers are responsible for their products and applications using TI components. To minimize the risks associated with Buyers' products and applications, Buyers should provide adequate design and operating safeguards.

TI does not warrant or represent that any license, either express or implied, is granted under any patent right, copyright, mask work right, or other intellectual property right relating to any combination, machine, or process in which TI components or services are used. Information published by TI regarding third-party products or services does not constitute a license to use such products or services or a warranty or endorsement thereof. Use of such information may require a license from a third party under the patents or other intellectual property of the third party, or a license from TI under the patents or other intellectual property of TI.

Reproduction of significant portions of TI information in TI data books or data sheets is permissible only if reproduction is without alteration and is accompanied by all associated warranties, conditions, limitations, and notices. TI is not responsible or liable for such altered documentation. Information of third parties may be subject to additional restrictions.

Resale of TI components or services with statements different from or beyond the parameters stated by TI for that component or service voids all express and any implied warranties for the associated TI component or service and is an unfair and deceptive business practice. TI is not responsible or liable for any such statements.

Buyer acknowledges and agrees that it is solely responsible for compliance with all legal, regulatory and safety-related requirements concerning its products, and any use of TI components in its applications, notwithstanding any applications-related information or support that may be provided by TI. Buyer represents and agrees that it has all the necessary expertise to create and implement safeguards which anticipate dangerous consequences of failures, monitor failures and their consequences, lessen the likelihood of failures that might cause harm and take appropriate remedial actions. Buyer will fully indemnify TI and its representatives against any damages arising out of the use of any TI components in safety-critical applications.

In some cases, TI components may be promoted specifically to facilitate safety-related applications. With such components, TI's goal is to help enable customers to design and create their own end-product solutions that meet applicable functional safety standards and requirements. Nonetheless, such components are subject to these terms.

No TI components are authorized for use in FDA Class III (or similar life-critical medical equipment) unless authorized officers of the parties have executed a special agreement specifically governing such use.

Only those TI components which TI has specifically designated as military grade or "enhanced plastic" are designed and intended for use in military/aerospace applications or environments. Buyer acknowledges and agrees that any military or aerospace use of TI components which have **not** been so designated is solely at the Buyer's risk, and that Buyer is solely responsible for compliance with all legal and regulatory requirements in connection with such use.

TI has specifically designated certain components as meeting ISO/TS16949 requirements, mainly for automotive use. In any case of use of non-designated products, TI will not be responsible for any failure to meet ISO/TS16949.

Products

Audio	www.ti.com/audio
Amplifiers	amplifier.ti.com
Data Converters	dataconverter.ti.com
DLP® Products	www.dlp.com
DSP	dsp.ti.com
Clocks and Timers	www.ti.com/clocks
Interface	interface.ti.com
Logic	logic.ti.com
Power Mgmt	power.ti.com
Microcontrollers	microcontroller.ti.com
RFID	www.ti-rfid.com
OMAP Applications Processors	www.ti.com/omap
Wireless Connectivity	www.ti.com/wirelessconnectivity

Applications

Automotive and Transportation	www.ti.com/automotive
Communications and Telecom	www.ti.com/communications
Computers and Peripherals	www.ti.com/computers
Consumer Electronics	www.ti.com/consumer-apps
Energy and Lighting	www.ti.com/energy
Industrial	www.ti.com/industrial
Medical	www.ti.com/medical
Security	www.ti.com/security
Space, Avionics and Defense	www.ti.com/space-avionics-defense
Video and Imaging	www.ti.com/video

TI E2E Community

e2e.ti.com