

SN74CBTLV3253 Low-Voltage Dual 1-of-4 FET Multiplexer/Demultiplexer

1 Features

- Functionally Equivalent to QS3253
- 5-Ω Switch Connection Between Two Ports
- Rail-to-Rail Switching on Data I/O Ports
- I_{off} Supports Partial-Power-Down Mode Operation
- Latch-Up Performance Exceeds 100 mA Per JESD 78, Class II

2 Applications

- Video Broadcasting: IP-Based Multi-Format Transcoders
- Video Communications Systems

3 Description

The SN74CBTLV3253 device is a dual 1-of-4 high-speed FET multiplexer and demultiplexer. The low ON-state resistance of the switch allows connections to be made with minimal propagation delay.

The select (S_0 , S_1) inputs control the data flow. The FET multiplexers/demultiplexers are disabled when the associated output-enable (\overline{OE}) input is high.

The SN74CBTLV3253 device is fully specified for partial-power-down applications using I_{off} . The I_{off} feature ensures that damaging current will not backflow through the device when it is powered down. The device has isolation during power off.

Device Information⁽¹⁾

| PART NUMBER | PACKAGE | BODY SIZE (NOM) |
|------------------|------------|-------------------|
| SN74CBTLV3253D | SOIC (16) | 9.90 mm × 3.90 mm |
| SN74CBTLV3253DBQ | SSOP (16) | 4.90 mm × 3.90 mm |
| SN74CBTLV3253DGV | TVSOP (16) | 3.60 mm × 4.40 mm |
| SN74CBTLV3253RGY | VQFN (16) | 4.00 mm × 3.50 mm |
| SN74CBTLV3253PW | TSSOP (16) | 5.00 mm × 4.40 mm |

(1) For all available packages, see the orderable addendum at the end of the data sheet.

Logic Diagram (Positive Logic)

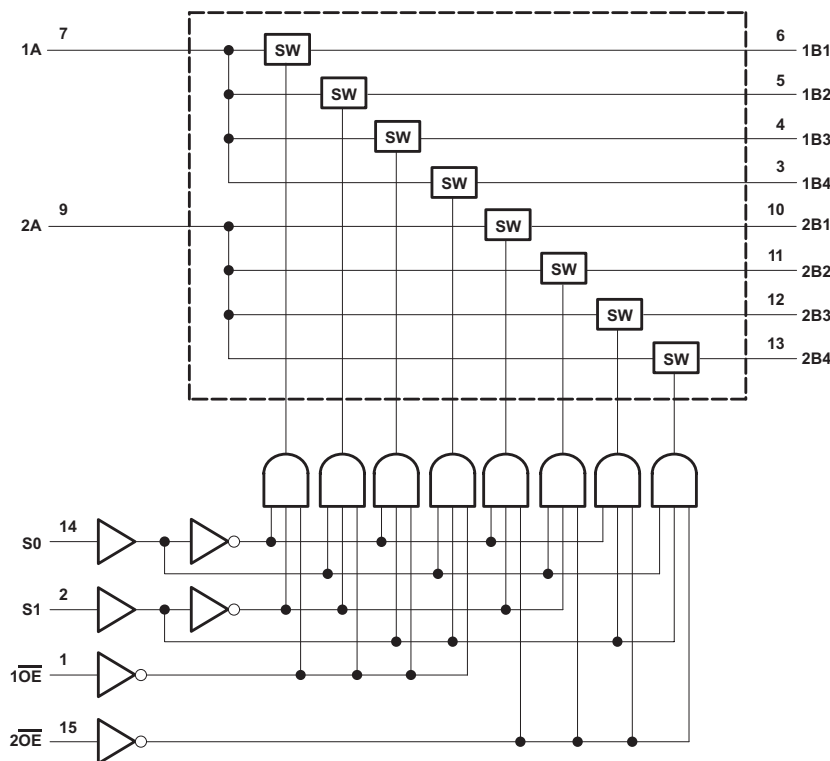

Table of Contents

| | |
|---|---|
| 1 Features 1 2 Applications 1 3 Description 1 4 Revision History 2 5 Pin Configuration and Functions 3 6 Specifications 4 6.1 Absolute Maximum Ratings 4 6.2 ESD Ratings 4 6.3 Recommended Operating Conditions 4 6.4 Thermal Information 4 6.5 Electrical Characteristics 5 6.6 Switching Characteristics 5 6.7 Typical Characteristics 6 7 Parameter Measurement Information 7 8 Detailed Description 8 8.1 Overview 8 8.2 Functional Block Diagram 8 | 8.3 Feature Description 8 8.4 Device Functional Modes 8 9 Application and Implementation 9 9.1 Application Information 9 9.2 Typical Application 9 10 Power Supply Recommendations 10 11 Layout 11 11.1 Layout Guidelines 11 11.2 Layout Example 11 12 Device and Documentation Support 12 12.1 Documentation Support 12 12.2 Community Resources 12 12.3 Trademarks 12 12.4 Electrostatic Discharge Caution 12 12.5 Glossary 12 13 Mechanical, Packaging, and Orderable Information 12 |
|---|---|

4 Revision History

NOTE: Page numbers for previous revisions may differ from page numbers in the current version.

| Changes from Revision H (February 2014) to Revision I | Page |
|---|------|
| <ul style="list-style-type: none"> • Added <i>Applications</i> section, <i>Device Information</i> table, <i>Pin Configuration and Functions</i> section, <i>ESD Ratings</i> table, <i>Feature Description</i> section, <i>Device Functional Modes</i>, <i>Application and Implementation</i> section, <i>Power Supply Recommendations</i> section, <i>Layout</i> section, <i>Device and Documentation Support</i> section, and <i>Mechanical, Packaging, and Orderable Information</i> section 1 | 1 |
| | |
| Changes from Revision G (February 2014) to Revision H | Page |
| <ul style="list-style-type: none"> • Updated data sheet – no specific changes 1 | 1 |
| | |
| Changes from Revision F (July 2012) to Revision G | Page |
| <ul style="list-style-type: none"> • Deleted <i>Ordering Information</i> table. 1 | 1 |

5 Pin Configuration and Functions

D, DBQ, DGV, or PW Package
16-Pin SOIC, SSOP, TVSOP, or TSSOP
Top View

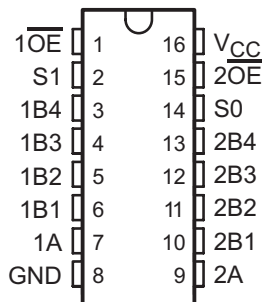

RGY Package
16-Pin VQFN
Top View

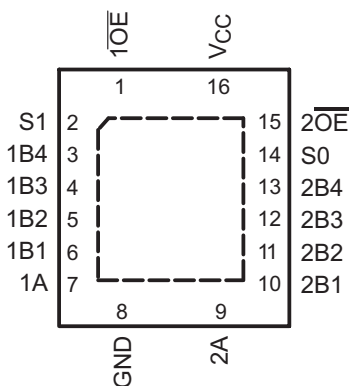

Pin Functions

| PIN | | I/O | DESCRIPTION |
|------------------|-----|-----|----------------------------|
| NAME | NO. | | |
| $\overline{1OE}$ | 1 | I | Output Enable 1 Active-Low |
| S1 | 2 | I | Select Pin 1 |
| 1B4 | 3 | I/O | Channel 1 I/O 4 |
| 1B3 | 4 | I/O | Channel 1 I/O 3 |
| 1B2 | 5 | I/O | Channel 1 I/O 2 |
| 1B1 | 6 | I/O | Channel 1 I/O 1 |
| 1A | 7 | I/O | Channel 1 common |
| GND | 8 | — | Ground |
| 2A | 9 | I/O | Channel 2 common |
| 2B1 | 10 | I/O | Channel 2 I/O 1 |
| 2B2 | 11 | I/O | Channel 2 I/O 2 |
| 2B3 | 12 | I/O | Channel 2 I/O 3 |
| 2B4 | 13 | I/O | Channel 2 I/O 4 |
| S0 | 14 | I | Select Pin 0 |
| $\overline{2OE}$ | 15 | I | Output Enable 2 Active-Low |
| V _{CC} | 16 | — | Power |

6 Specifications

6.1 Absolute Maximum Ratings

 over operating free-air temperature range (unless otherwise noted)⁽¹⁾

| | | MIN | MAX | UNIT |
|---|--------------------------------------|----------------------|------|------|
| V _{CC} | Supply voltage | -0.5 | 4.6 | V |
| V _{IN} | Control input voltage ⁽²⁾ | -0.5 | 4.6 | V |
| V _{I/O} | Switch I/O voltage ⁽²⁾ | -0.5 | 4.6 | V |
| I _{IK} | Control input clamp current | V _{IN} < 0 | -50 | mA |
| I _{I/OK} | I/O port clamp current | V _{I/O} < 0 | -50 | mA |
| Continuous current through V _{CC} or GND | | | ±128 | mA |
| T _J | Junction temperature | | 150 | °C |
| T _{stg} | Storage temperature | -65 | 150 | °C |

- (1) Stresses beyond those listed under *Absolute Maximum Ratings* may cause permanent damage to the device. These are stress ratings only, and functional operation of the device at these or any other conditions beyond those indicated under *Recommended Operating Conditions* is not implied. Exposure to absolute-maximum-rated conditions for extended periods may affect device reliability.
- (2) The input and output negative-voltage ratings may be exceeded if the input and output clamp-current ratings are observed.

6.2 ESD Ratings

| | | VALUE | UNIT | |
|------------------|-------------------------|--|-------|---|
| V _{ESD} | Electrostatic discharge | Human Body Model (HBM), per ANSI/ESDA/JEDEC JS-001, all pins ⁽¹⁾ | +2000 | V |
| | | Charged-Device Model (CDM), per JEDEC specification JESD22-C101, all pins ⁽²⁾ | +1000 | V |

- (1) JEDEC document JEP155 states that 500-V HBM allows safe manufacturing with a standard ESD control process.
- (2) JEDEC document JEP157 states that 250-V CDM allows safe manufacturing with a standard ESD control process.

6.3 Recommended Operating Conditions

 over operating free-air temperature range (unless otherwise noted)⁽¹⁾

| | | MIN | MAX | UNIT |
|-----------------|----------------------------------|----------------------------------|-----|------|
| V _{CC} | Supply voltage | 2.3 | 3.6 | V |
| V _{IH} | High-level control input voltage | V _{CC} = 2.3 V to 2.7 V | 1.7 | V |
| | | V _{CC} = 2.7 V to 3.6 V | 2 | |
| V _{IL} | Low-level control input voltage | V _{CC} = 2.3 V to 2.7 V | 0.7 | V |
| | | V _{CC} = 2.7 V to 3.6 V | 0.8 | |
| T _A | Operating free-air temperature | -40 | 85 | °C |

- (1) All unused control inputs of the device must be held at V_{CC} or GND to ensure proper device operation. Refer to the TI application report, *Implications of Slow or Floating CMOS Inputs*, [SCBA004](#).

6.4 Thermal Information

| THERMAL METRIC ⁽¹⁾ | SN74CBTLV3253 | | | | | UNIT | |
|-------------------------------|--|------------|-------------|------------|------------|------|------|
| | D (SOIC) | DBQ (SSOP) | DGV (TVSOP) | PW (TSSOP) | RGY (VQFN) | | |
| | 16 PINS | 16 PINS | 16 PINS | 16 PINS | 16 PINS | | |
| R _{θJA} | Junction-to-ambient thermal resistance | 73 | 90 | 120 | 108 | 39 | °C/W |

- (1) For more information about traditional and new thermal metrics, see the *Semiconductor and IC Package Thermal Metrics* application report, [SPRA953](#).

6.5 Electrical Characteristics

over recommended operating free-air temperature range (unless otherwise noted)

| PARAMETER | | TEST CONDITIONS | | MIN | TYP ⁽¹⁾ | MAX | UNIT |
|--------------------------------|---|---------------------------|---------------------------------|-----|--------------------|----------|---------------|
| V_{IK} | | $V_{CC} = 3\text{ V}$, | $I_I = -18\text{ mA}$ | | | -1.2 | V |
| I_I | | $V_{CC} = 3.6\text{ V}$, | $V_I = V_{CC}$ or GND | | | ± 1 | μA |
| I_{off} | | $V_{CC} = 0$, | V_I or $V_O = 0$ to 3.6 V | | | 15 | μA |
| I_{CC} | | $V_{CC} = 3.6\text{ V}$, | $I_O = 0$, | | | 10 | μA |
| ΔI_{CC} ⁽²⁾ | Control inputs | $V_{CC} = 3.6\text{ V}$, | One input at 3 V, | | | 300 | μA |
| | | | Other inputs at V_{CC} or GND | | | | |
| C_i | Control inputs | $V_I = 3\text{ V}$ or 0 | | | 3 | | pF |
| $C_{io(OFF)}$ | A port | $V_O = 3\text{ V}$ or 0, | $\overline{OE} = V_{CC}$ | | 20.5 | | pF |
| | B port | | | | 5.5 | | |
| r_{on} ⁽³⁾ | $V_{CC} = 2.3\text{ V}$, TYP at $V_{CC} = 2.5\text{ V}$ | $V_I = 0$ | $I_I = 64\text{ mA}$ | 5 | 8 | Ω | |
| | | | $I_I = 24\text{ mA}$ | 5 | 8 | | |
| | | $V_I = 1.7\text{ V}$, | $I_I = 15\text{ mA}$ | 27 | 40 | | |
| | $V_{CC} = 3\text{ V}$ | $V_I = 0$ | $I_I = 64\text{ mA}$ | 5 | 7 | | |
| | | | $I_I = 24\text{ mA}$ | 5 | 7 | | |
| | | $V_I = 2.4\text{ V}$, | $I_I = 15\text{ mA}$ | 10 | 15 | | |

(1) All typical values are at $V_{CC} = 3.3\text{ V}$ (unless otherwise noted), $T_A = 25^\circ\text{C}$.

(2) This is the increase in supply current for each input that is at the specified voltage level, rather than V_{CC} or GND.

(3) Measured by the voltage drop between the A and the B terminals at the indicated current through the switch. On-state resistance is determined by the lower of the voltages of the two (A or B) terminals.

6.6 Switching Characteristics

over recommended operating free-air temperature range (unless otherwise noted) (see [Figure 2](#))

| PARAMETER | FROM (INPUT) | TO (OUTPUT) | $V_{CC} = 2.5\text{ V} \pm 0.2\text{ V}$ | | $V_{CC} = 3.3\text{ V} \pm 0.3\text{ V}$ | | UNIT |
|-----------|-----------------------|-------------|--|------|--|------|------|
| | | | MIN | MAX | MIN | MAX | |
| t_{pd} | A or B ⁽¹⁾ | B or A | | 0.15 | | 0.25 | ns |
| | S | A or B | 1 | 6.8 | 1 | 5.5 | |
| t_{en} | S | A or B | 1 | 4.3 | 1 | 4 | ns |
| t_{dis} | S | A or B | 1 | 5.1 | 1 | 5.5 | ns |
| t_{en} | \overline{OE} | A or B | 1 | 5 | 1 | 4.8 | ns |
| t_{dis} | \overline{OE} | A or B | 1 | 5.5 | 1 | 5.4 | ns |

(1) The propagation delay is the calculated RC time constant of the typical on-state resistance of the switch and the specified load capacitance, when driven by an ideal voltage source (zero output impedance).

6.7 Typical Characteristics

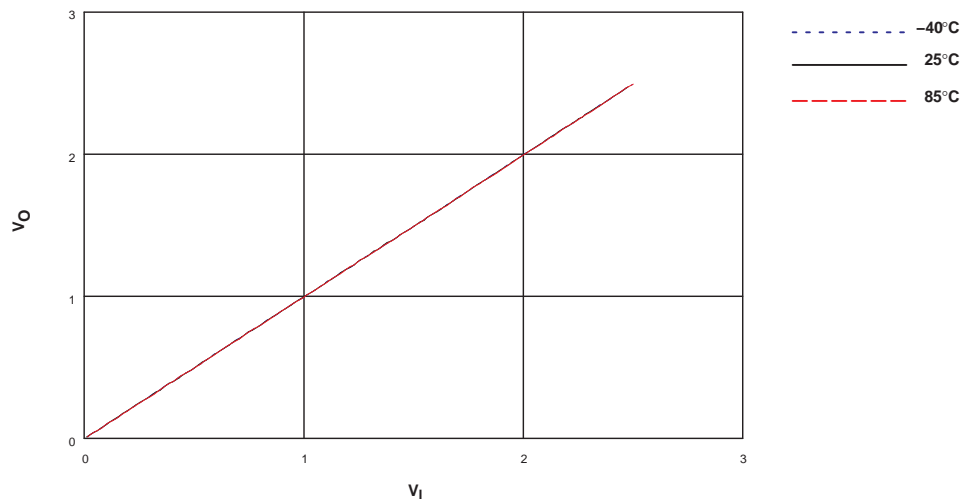
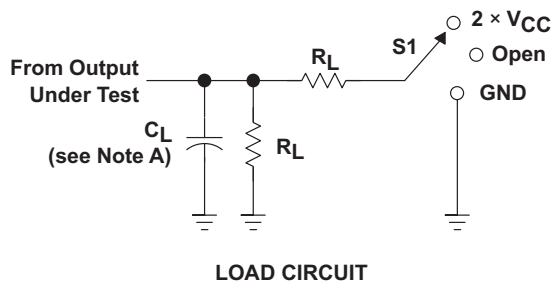

Figure 1. V_O vs V_I , $V_{CC} = 2.5$ V

7 Parameter Measurement Information



| TEST | S1 |
|-------------------|-------------------|
| t_{PLH}/t_{PHL} | Open |
| t_{PLZ}/t_{PZL} | $2 \times V_{CC}$ |
| t_{PHZ}/t_{PZH} | GND |

| V_{CC} | C_L | R_L | V_{Δ} |
|-----------------------------------|-------|--------------|--------------|
| $2.5 \text{ V} \pm 0.2 \text{ V}$ | 30 pF | 500 Ω | 0.15 V |
| $3.3 \text{ V} \pm 0.3 \text{ V}$ | 50 pF | 500 Ω | 0.3 V |

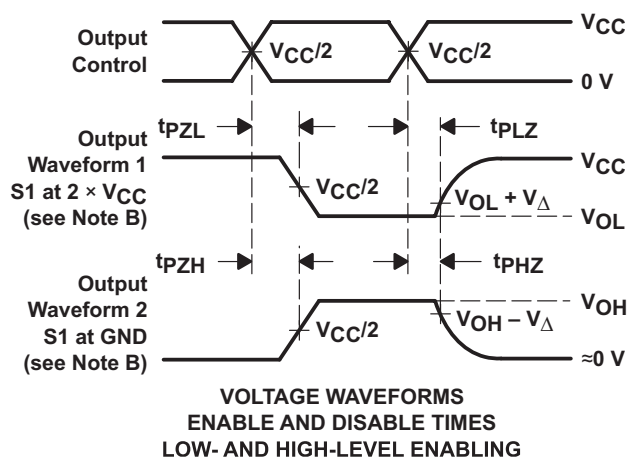
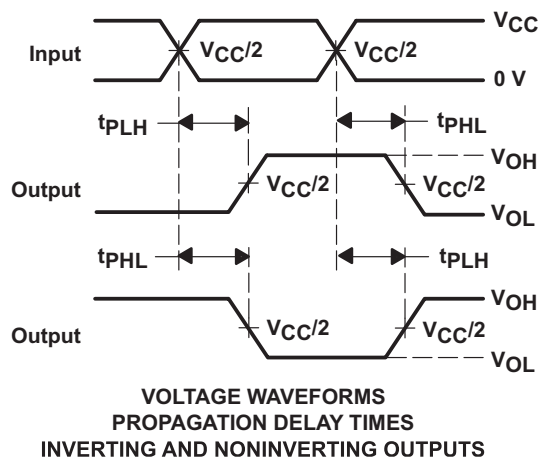
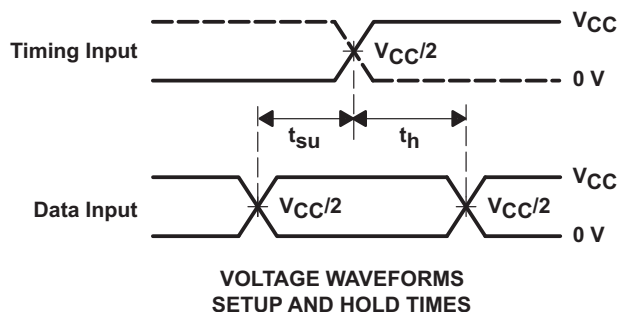
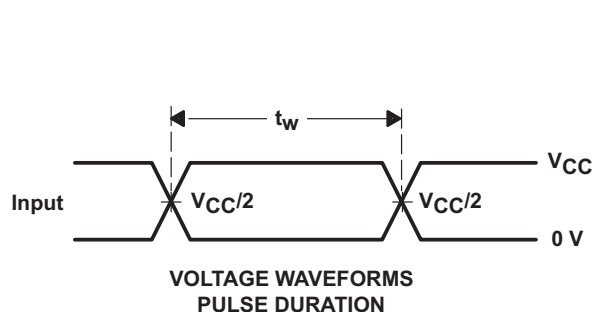

Figure 2. Test Circuit and Voltage Waveforms

8 Detailed Description

8.1 Overview

The SN74CBTLV3253 device is a dual 1-of-4 high-speed FET multiplexer/demultiplexer. The low ON-state resistance of the switch allows connections to be made with minimal propagation delay.

The select (S0, S1) inputs control the data flow. The FET multiplexers and demultiplexers are disabled when the associated output-enable (\overline{OE}) input is high.

The SN74CBTLV3253 device is fully specified for partial-power-down applications using I_{off} . The I_{off} feature ensures that damaging current will not backflow through the device when it is powered down. The device has isolation during power off.

To ensure the high-impedance state during power up or power down, \overline{OE} should be tied to V_{CC} through a pullup resistor; the minimum value of the resistor is determined by the current-sinking capability of the driver.

8.2 Functional Block Diagram

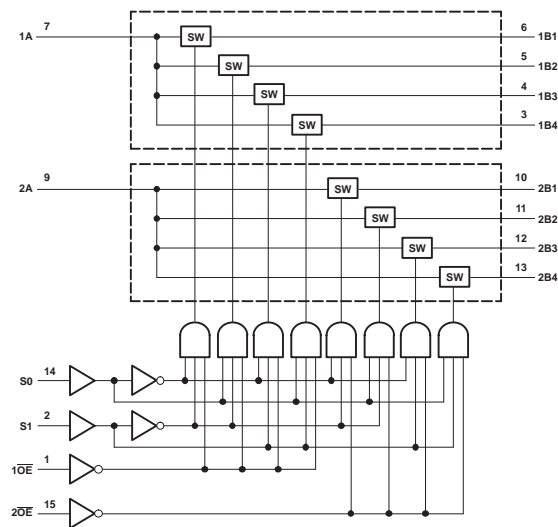

8.3 Feature Description

The SN74CBTLV3253 device is functionally equivalent to the QS3253 and has a 5- Ω switch connection between two ports

It also has rail-to-rail switching on data I/O ports as well as I_{off} supporting partial-power-down mode operation

8.4 Device Functional Modes

Table 1 lists the functional modes of the SN74CBTLV3253.

**Table 1. Function Table
(Each Multiplexer/Demultiplexer)**

| INPUTS | | | FUNCTION |
|-----------------|----|----|------------------|
| \overline{OE} | S1 | S0 | |
| L | L | L | A port = B1 port |
| L | L | H | A port = B2 port |
| L | H | L | A port = B3 port |
| L | H | H | A port = B4 port |
| H | X | X | Disconnect |

9 Application and Implementation

NOTE

Information in the following applications sections is not part of the TI component specification, and TI does not warrant its accuracy or completeness. TI's customers are responsible for determining suitability of components for their purposes. Customers should validate and test their design implementation to confirm system functionality.

9.1 Application Information

The SN74CBTLV3253 can be used to multiplex and demultiplex up to 2 channels simultaneously in a 4:1 configuration. The application shown here is a 2-bit bus being multiplexed between two devices. the \overline{OE} and S pins are used to control the chip from the bus controller. This is a very generic example, and could apply to many situations.

9.2 Typical Application

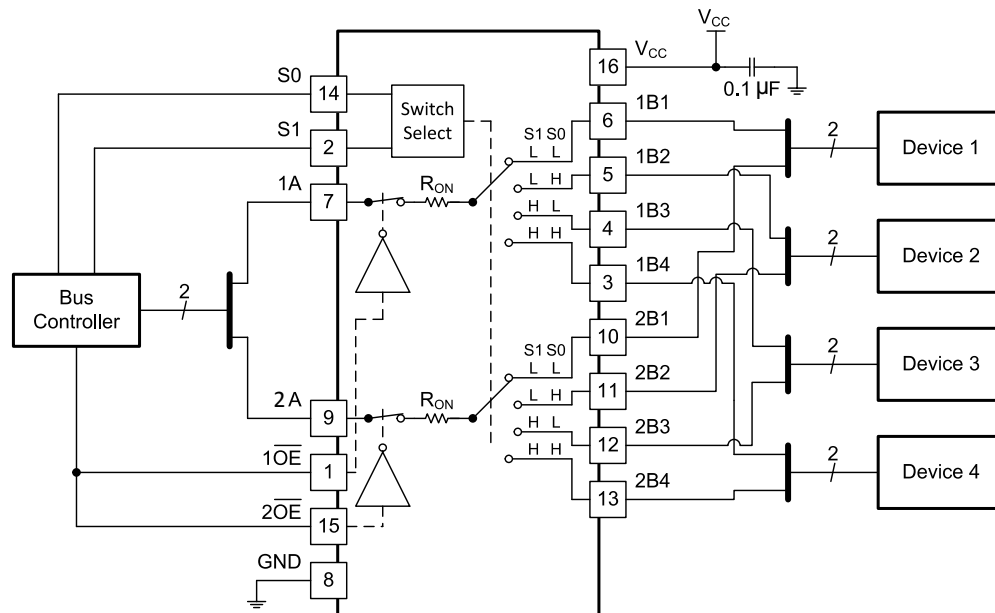

Figure 3. Typical Application of the SN74CBTLV3253

9.2.1 Design Requirements

The 0.1µF capacitor should be placed as close as possible to the device.

9.2.2 Detailed Design Procedure

- Recommended Input Conditions:
 - For specified high and low levels, see V_{IH} and V_{IL} in [Recommended Operating Conditions](#).
 - Inputs and outputs are overvoltage tolerant allowing them to go as high as 4.6 V at any valid V_{CC} .
- Recommended Output Conditions:
 - Load currents should not exceed ± 128 mA per channel.
- Frequency Selection Criterion:
 - Added trace resistance/capacitance can reduce maximum frequency capability; use layout practices as directed in [Layout](#).

Typical Application (continued)

9.2.3 Application Curve

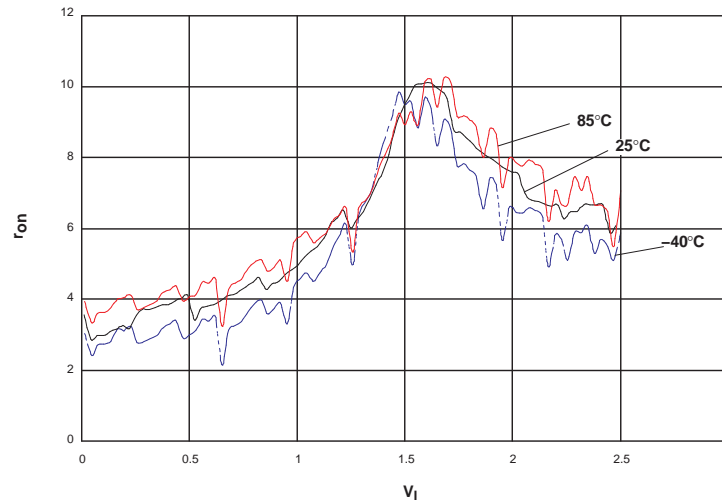

Figure 4. r_{on} vs V_I , $V_{CC} = 2.5$ V

10 Power Supply Recommendations

The power supply can be any voltage between the minimum and maximum supply voltage rating listed in the [Recommended Operating Conditions](#) table.

Each V_{CC} terminal should have a good bypass capacitor to prevent power disturbance. For devices with a single supply, a 0.1- μ F bypass capacitor is recommended. If multiple pins are labeled V_{CC} , then a 0.01- μ F or 0.022- μ F capacitor is recommended for each V_{CC} because the V_{CC} pins are tied together internally. For devices with dual-supply pins operating at different voltages, for example V_{CC} and V_{DD} , a 0.1- μ F bypass capacitor is recommended for each supply pin. To reject different frequencies of noise, use multiple bypass capacitors in parallel. Capacitors with values of 0.1 μ F and 1 μ F are commonly used in parallel. The bypass capacitor should be installed as close to the power terminal as possible for best results.

11 Layout

11.1 Layout Guidelines

Reflections and matching are closely related to the loop antenna theory but are different enough to be discussed separately from the theory. When a PCB trace turns a corner at a 90° angle, a reflection can occur. A reflection occurs primarily because of the change of width of the trace. At the apex of the turn, the trace width increases to 1.414 times the width. This increase upsets the transmission-line characteristics, especially the distributed capacitance and self-inductance of the trace which results in the reflection. Not all PCB traces can be straight and therefore some traces must turn corners. Figure 5 shows progressively better techniques of rounding corners. Only the last example (BEST) maintains constant trace width and minimizes reflections.

11.2 Layout Example

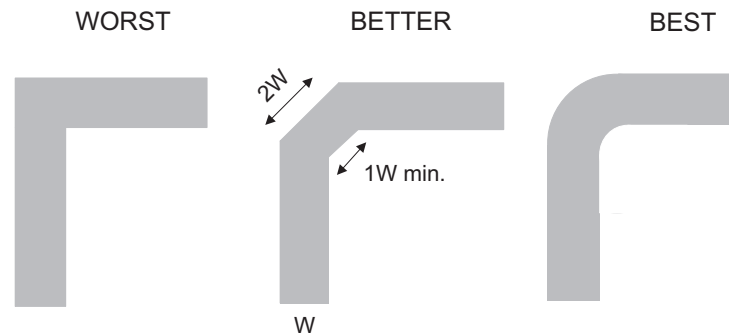

Figure 5. Trace Example

12 Device and Documentation Support

12.1 Documentation Support

12.1.1 Related Documentation

For related documentation, see the following:

Implications of Slow or Floating CMOS Inputs, [SCBA004](#)

12.2 Community Resources

The following links connect to TI community resources. Linked contents are provided "AS IS" by the respective contributors. They do not constitute TI specifications and do not necessarily reflect TI's views; see TI's [Terms of Use](#).

TI E2E™ Online Community *TI's Engineer-to-Engineer (E2E) Community*. Created to foster collaboration among engineers. At [e2e.ti.com](#), you can ask questions, share knowledge, explore ideas and help solve problems with fellow engineers.

Design Support *TI's Design Support* Quickly find helpful E2E forums along with design support tools and contact information for technical support.

12.3 Trademarks

E2E is a trademark of Texas Instruments.
All other trademarks are the property of their respective owners.

12.4 Electrostatic Discharge Caution



These devices have limited built-in ESD protection. The leads should be shorted together or the device placed in conductive foam during storage or handling to prevent electrostatic damage to the MOS gates.

12.5 Glossary

[SLYZ022](#) — *TI Glossary*.

This glossary lists and explains terms, acronyms, and definitions.

13 Mechanical, Packaging, and Orderable Information

The following pages include mechanical, packaging, and orderable information. This information is the most current data available for the designated devices. This data is subject to change without notice and revision of this document. For browser-based versions of this data sheet, refer to the left-hand navigation.

PACKAGING INFORMATION

| Orderable Device | Status (1) | Package Type | Package Drawing | Pins | Package Qty | Eco Plan (2) | Lead/Ball Finish (6) | MSL Peak Temp (3) | Op Temp (°C) | Device Marking (4/5) | Samples |
|--------------------|---------------|--------------|-----------------|------|-------------|-------------------------|-------------------------|----------------------|--------------|-------------------------|-------------------------|
| 74CBTLV3253DBQRG4 | ACTIVE | SSOP | DBQ | 16 | 2500 | Green (RoHS & no Sb/Br) | CU NIPDAU | Level-2-260C-1 YEAR | -40 to 85 | CL253 | Samples |
| 74CBTLV3253DGVRE4 | ACTIVE | TVSOP | DGV | 16 | 2000 | Green (RoHS & no Sb/Br) | CU NIPDAU | Level-1-260C-UNLIM | -40 to 85 | CL253 | Samples |
| 74CBTLV3253PWRE4 | ACTIVE | TSSOP | PW | 16 | 2000 | Green (RoHS & no Sb/Br) | CU NIPDAU | Level-1-260C-UNLIM | -40 to 85 | CL253 | Samples |
| 74CBTLV3253PWVG4 | ACTIVE | TSSOP | PW | 16 | 2000 | Green (RoHS & no Sb/Br) | CU NIPDAU | Level-1-260C-UNLIM | -40 to 85 | CL253 | Samples |
| SN74CBTLV3253D | ACTIVE | SOIC | D | 16 | 40 | Green (RoHS & no Sb/Br) | CU NIPDAU | Level-1-260C-UNLIM | -40 to 85 | CBTLV3253 | Samples |
| SN74CBTLV3253DBQR | ACTIVE | SSOP | DBQ | 16 | 2500 | Green (RoHS & no Sb/Br) | CU NIPDAU | Level-2-260C-1 YEAR | -40 to 85 | CL253 | Samples |
| SN74CBTLV3253DE4 | ACTIVE | SOIC | D | 16 | 40 | Green (RoHS & no Sb/Br) | CU NIPDAU | Level-1-260C-UNLIM | -40 to 85 | CBTLV3253 | Samples |
| SN74CBTLV3253DG4 | ACTIVE | SOIC | D | 16 | 40 | Green (RoHS & no Sb/Br) | CU NIPDAU | Level-1-260C-UNLIM | -40 to 85 | CBTLV3253 | Samples |
| SN74CBTLV3253DGV | ACTIVE | TVSOP | DGV | 16 | 2000 | Green (RoHS & no Sb/Br) | CU NIPDAU | Level-1-260C-UNLIM | -40 to 85 | CL253 | Samples |
| SN74CBTLV3253DR | ACTIVE | SOIC | D | 16 | 2500 | Green (RoHS & no Sb/Br) | CU NIPDAU | Level-1-260C-UNLIM | -40 to 85 | CBTLV3253 | Samples |
| SN74CBTLV3253DRE4 | ACTIVE | SOIC | D | 16 | 2500 | Green (RoHS & no Sb/Br) | CU NIPDAU | Level-1-260C-UNLIM | -40 to 85 | CBTLV3253 | Samples |
| SN74CBTLV3253PW | ACTIVE | TSSOP | PW | 16 | 90 | Green (RoHS & no Sb/Br) | CU NIPDAU | Level-1-260C-UNLIM | -40 to 85 | CL253 | Samples |
| SN74CBTLV3253PWVG4 | ACTIVE | TSSOP | PW | 16 | 90 | Green (RoHS & no Sb/Br) | CU NIPDAU | Level-1-260C-UNLIM | -40 to 85 | CL253 | Samples |
| SN74CBTLV3253PWR | ACTIVE | TSSOP | PW | 16 | 2000 | Green (RoHS & no Sb/Br) | CU NIPDAU | Level-1-260C-UNLIM | -40 to 85 | CL253 | Samples |
| SN74CBTLV3253RGRYR | ACTIVE | VQFN | RGY | 16 | 3000 | Green (RoHS & no Sb/Br) | CU NIPDAU | Level-2-260C-1 YEAR | -40 to 85 | CL253 | Samples |

(1) The marketing status values are defined as follows:

ACTIVE: Product device recommended for new designs.

LIFEBUY: TI has announced that the device will be discontinued, and a lifetime-buy period is in effect.

NRND: Not recommended for new designs. Device is in production to support existing customers, but TI does not recommend using this part in a new design.

PREVIEW: Device has been announced but is not in production. Samples may or may not be available.

OBSOLETE: TI has discontinued the production of the device.

⁽²⁾ Eco Plan - The planned eco-friendly classification: Pb-Free (RoHS), Pb-Free (RoHS Exempt), or Green (RoHS & no Sb/Br) - please check <http://www.ti.com/productcontent> for the latest availability information and additional product content details.

TBD: The Pb-Free/Green conversion plan has not been defined.

Pb-Free (RoHS): TI's terms "Lead-Free" or "Pb-Free" mean semiconductor products that are compatible with the current RoHS requirements for all 6 substances, including the requirement that lead not exceed 0.1% by weight in homogeneous materials. Where designed to be soldered at high temperatures, TI Pb-Free products are suitable for use in specified lead-free processes.

Pb-Free (RoHS Exempt): This component has a RoHS exemption for either 1) lead-based flip-chip solder bumps used between the die and package, or 2) lead-based die adhesive used between the die and leadframe. The component is otherwise considered Pb-Free (RoHS compatible) as defined above.

Green (RoHS & no Sb/Br): TI defines "Green" to mean Pb-Free (RoHS compatible), and free of Bromine (Br) and Antimony (Sb) based flame retardants (Br or Sb do not exceed 0.1% by weight in homogeneous material)

⁽³⁾ MSL, Peak Temp. - The Moisture Sensitivity Level rating according to the JEDEC industry standard classifications, and peak solder temperature.

⁽⁴⁾ There may be additional marking, which relates to the logo, the lot trace code information, or the environmental category on the device.

⁽⁵⁾ Multiple Device Markings will be inside parentheses. Only one Device Marking contained in parentheses and separated by a "~" will appear on a device. If a line is indented then it is a continuation of the previous line and the two combined represent the entire Device Marking for that device.

⁽⁶⁾ Lead/Ball Finish - Orderable Devices may have multiple material finish options. Finish options are separated by a vertical ruled line. Lead/Ball Finish values may wrap to two lines if the finish value exceeds the maximum column width.

Important Information and Disclaimer: The information provided on this page represents TI's knowledge and belief as of the date that it is provided. TI bases its knowledge and belief on information provided by third parties, and makes no representation or warranty as to the accuracy of such information. Efforts are underway to better integrate information from third parties. TI has taken and continues to take reasonable steps to provide representative and accurate information but may not have conducted destructive testing or chemical analysis on incoming materials and chemicals. TI and TI suppliers consider certain information to be proprietary, and thus CAS numbers and other limited information may not be available for release.

In no event shall TI's liability arising out of such information exceed the total purchase price of the TI part(s) at issue in this document sold by TI to Customer on an annual basis.

TAPE AND REEL INFORMATION

QUADRANT ASSIGNMENTS FOR PIN 1 ORIENTATION IN TAPE

*All dimensions are nominal

| Device | Package Type | Package Drawing | Pins | SPQ | Reel Diameter (mm) | Reel Width W1 (mm) | A0 (mm) | B0 (mm) | K0 (mm) | P1 (mm) | W (mm) | Pin1 Quadrant |
|-------------------|--------------|-----------------|------|------|--------------------|--------------------|---------|---------|---------|---------|--------|---------------|
| SN74CBTLV3253DGVR | TVSOP | DGV | 16 | 2000 | 330.0 | 12.4 | 6.8 | 4.0 | 1.6 | 8.0 | 12.0 | Q1 |
| SN74CBTLV3253DR | SOIC | D | 16 | 2500 | 330.0 | 16.4 | 6.5 | 10.3 | 2.1 | 8.0 | 16.0 | Q1 |
| SN74CBTLV3253PWR | TSSOP | PW | 16 | 2000 | 330.0 | 12.4 | 6.9 | 5.6 | 1.6 | 8.0 | 12.0 | Q1 |
| SN74CBTLV3253RGYR | VQFN | RGY | 16 | 3000 | 330.0 | 12.4 | 3.8 | 4.3 | 1.5 | 8.0 | 12.0 | Q1 |

TAPE AND REEL BOX DIMENSIONS

*All dimensions are nominal

| Device | Package Type | Package Drawing | Pins | SPQ | Length (mm) | Width (mm) | Height (mm) |
|-------------------|--------------|-----------------|------|------|-------------|------------|-------------|
| SN74CBTLV3253DGVR | TVSOP | DGV | 16 | 2000 | 367.0 | 367.0 | 35.0 |
| SN74CBTLV3253DR | SOIC | D | 16 | 2500 | 333.2 | 345.9 | 28.6 |
| SN74CBTLV3253PWR | TSSOP | PW | 16 | 2000 | 367.0 | 367.0 | 35.0 |
| SN74CBTLV3253RGYR | VQFN | RGY | 16 | 3000 | 367.0 | 367.0 | 35.0 |

DGV (R-PDSO-G**)

PLASTIC SMALL-OUTLINE

24 PINS SHOWN



- NOTES: A. All linear dimensions are in millimeters.
 B. This drawing is subject to change without notice.
 C. Body dimensions do not include mold flash or protrusion, not to exceed 0,15 per side.
 D. Falls within JEDEC: 24/48 Pins – MO-153
 14/16/20/56 Pins – MO-194

D (R-PDSO-G16)

PLASTIC SMALL OUTLINE



4040047-6/M 06/11

- NOTES:
- A. All linear dimensions are in inches (millimeters).
 - B. This drawing is subject to change without notice.
 -  C. Body length does not include mold flash, protrusions, or gate burrs. Mold flash, protrusions, or gate burrs shall not exceed 0.006 (0,15) each side.
 -  D. Body width does not include interlead flash. Interlead flash shall not exceed 0.017 (0,43) each side.
 - E. Reference JEDEC MS-012 variation AC.

D (R-PDSO-G16)

PLASTIC SMALL OUTLINE



- NOTES:
- A. All linear dimensions are in millimeters.
 - B. This drawing is subject to change without notice.
 - C. Publication IPC-7351 is recommended for alternate designs.
 - D. Laser cutting apertures with trapezoidal walls and also rounding corners will offer better paste release. Customers should contact their board assembly site for stencil design recommendations. Refer to IPC-7525 for other stencil recommendations.
 - E. Customers should contact their board fabrication site for solder mask tolerances between and around signal pads.

PW (R-PDSO-G16)

PLASTIC SMALL OUTLINE

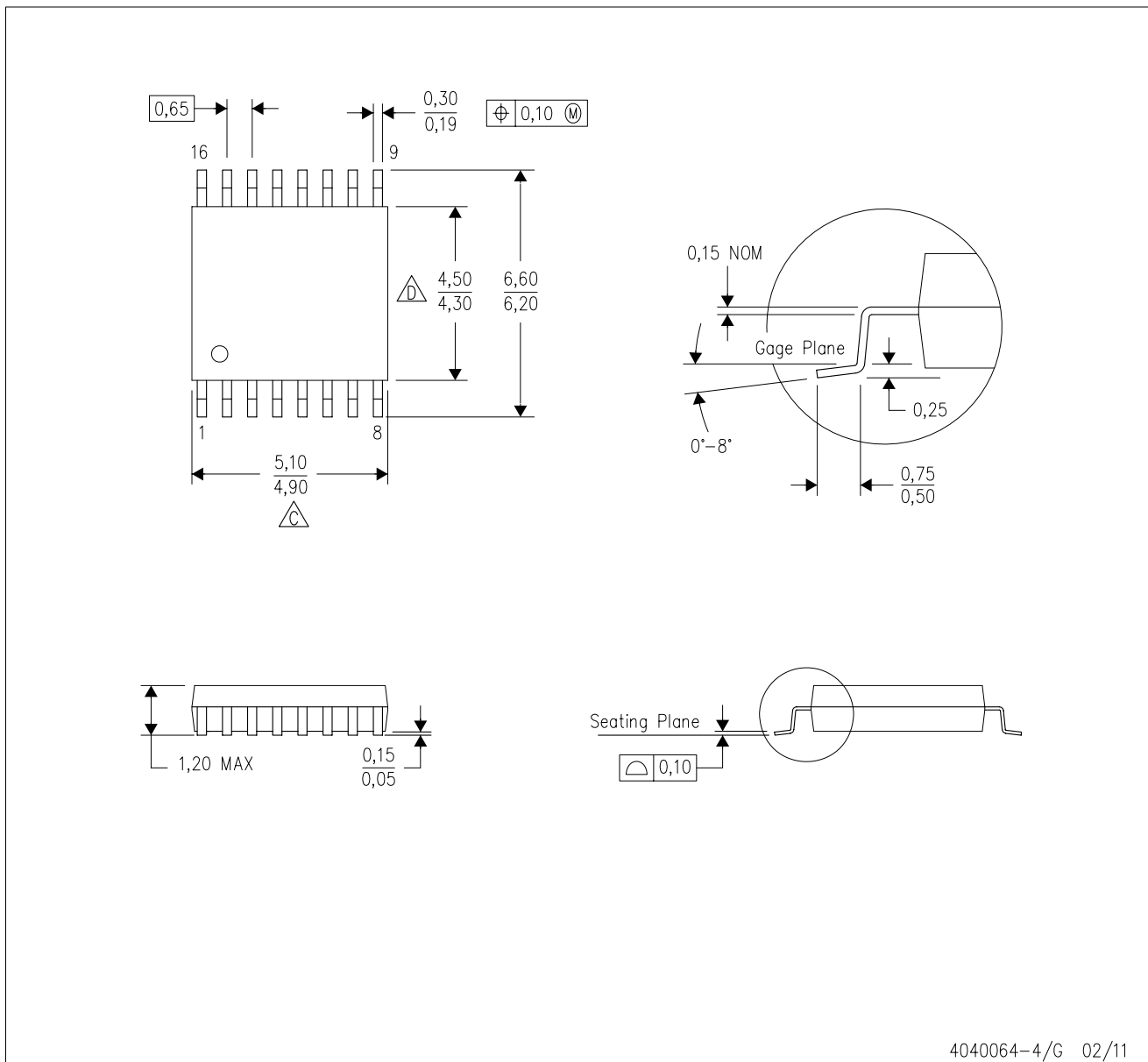

4040064-4/G 02/11

- NOTES:
- A. All linear dimensions are in millimeters. Dimensioning and tolerancing per ASME Y14.5M-1994.
 - B. This drawing is subject to change without notice.
 -  Body length does not include mold flash, protrusions, or gate burrs. Mold flash, protrusions, or gate burrs shall not exceed 0,15 each side.
 -  Body width does not include interlead flash. Interlead flash shall not exceed 0,25 each side.
 - E. Falls within JEDEC MO-153

PW (R-PDSO-G16)

PLASTIC SMALL OUTLINE



- NOTES:
- All linear dimensions are in millimeters.
 - This drawing is subject to change without notice.
 - Publication IPC-7351 is recommended for alternate designs.
 - Laser cutting apertures with trapezoidal walls and also rounding corners will offer better paste release. Customers should contact their board assembly site for stencil design recommendations. Refer to IPC-7525 for other stencil recommendations.
 - Customers should contact their board fabrication site for solder mask tolerances between and around signal pads.

RGY (R-PVQFN-N16)

PLASTIC QUAD FLATPACK NO-LEAD



- NOTES:
- A. All linear dimensions are in millimeters. Dimensioning and tolerancing per ASME Y14.5M-1994.
 - B. This drawing is subject to change without notice.
 - C. QFN (Quad Flatpack No-Lead) package configuration.
 - D. The package thermal pad must be soldered to the board for thermal and mechanical performance.
 - E. See the additional figure in the Product Data Sheet for details regarding the exposed thermal pad features and dimensions.
 - F. Pin 1 identifiers are located on both top and bottom of the package and within the zone indicated. The Pin 1 identifiers are either a molded, marked, or metal feature.
 - G. Package complies to JEDEC MO-241 variation BA.

RGY (R-PVQFN-N16)

PLASTIC QUAD FLATPACK NO-LEAD

THERMAL INFORMATION

This package incorporates an exposed thermal pad that is designed to be attached directly to an external heatsink. The thermal pad must be soldered directly to the printed circuit board (PCB). After soldering, the PCB can be used as a heatsink. In addition, through the use of thermal vias, the thermal pad can be attached directly to the appropriate copper plane shown in the electrical schematic for the device, or alternatively, can be attached to a special heatsink structure designed into the PCB. This design optimizes the heat transfer from the integrated circuit (IC).

For information on the Quad Flatpack No-Lead (QFN) package and its advantages, refer to Application Report, QFN/SON PCB Attachment, Texas Instruments Literature No. SLUA271. This document is available at www.ti.com.

The exposed thermal pad dimensions for this package are shown in the following illustration.

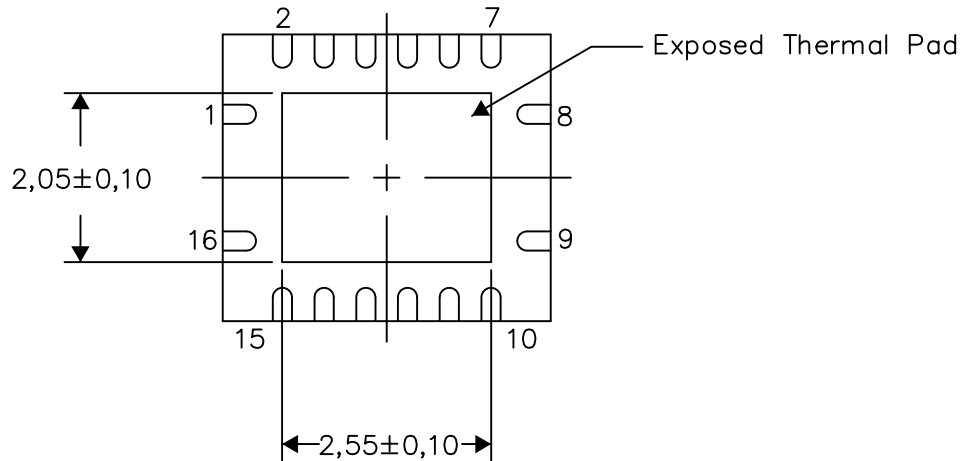

Bottom View

Exposed Thermal Pad Dimensions

4206353-3/P 03/14

NOTE: All linear dimensions are in millimeters

RGY (R-PVQFN-N16)

PLASTIC QUAD FLATPACK NO-LEAD



- NOTES:
- A. All linear dimensions are in millimeters.
 - B. This drawing is subject to change without notice.
 - C. Publication IPC-7351 is recommended for alternate designs.
 - D. This package is designed to be soldered to a thermal pad on the board. Refer to Application Note, Quad Flat-Pack QFN/SON PCB Attachment, Texas Instruments Literature No. SLUA271, and also the Product Data Sheets for specific thermal information, via requirements, and recommended board layout. These documents are available at www.ti.com <<http://www.ti.com>>.
 - E. Laser cutting apertures with trapezoidal walls and also rounding corners will offer better paste release. Customers should contact their board assembly site for stencil design recommendations. Refer to IPC 7525 for stencil design considerations.
 - F. Customers should contact their board fabrication site for minimum solder mask web tolerances between signal pads.

DBQ (R-PDSO-G16)

PLASTIC SMALL-OUTLINE PACKAGE



- NOTES:
- A. All linear dimensions are in inches (millimeters).
 - B. This drawing is subject to change without notice.
 - C. Body dimensions do not include mold flash or protrusion not to exceed 0.006 (0,15) per side.
 - D. Falls within JEDEC MO-137 variation AB.

DBQ (R-PDSO-G16)

PLASTIC SMALL OUTLINE PACKAGE

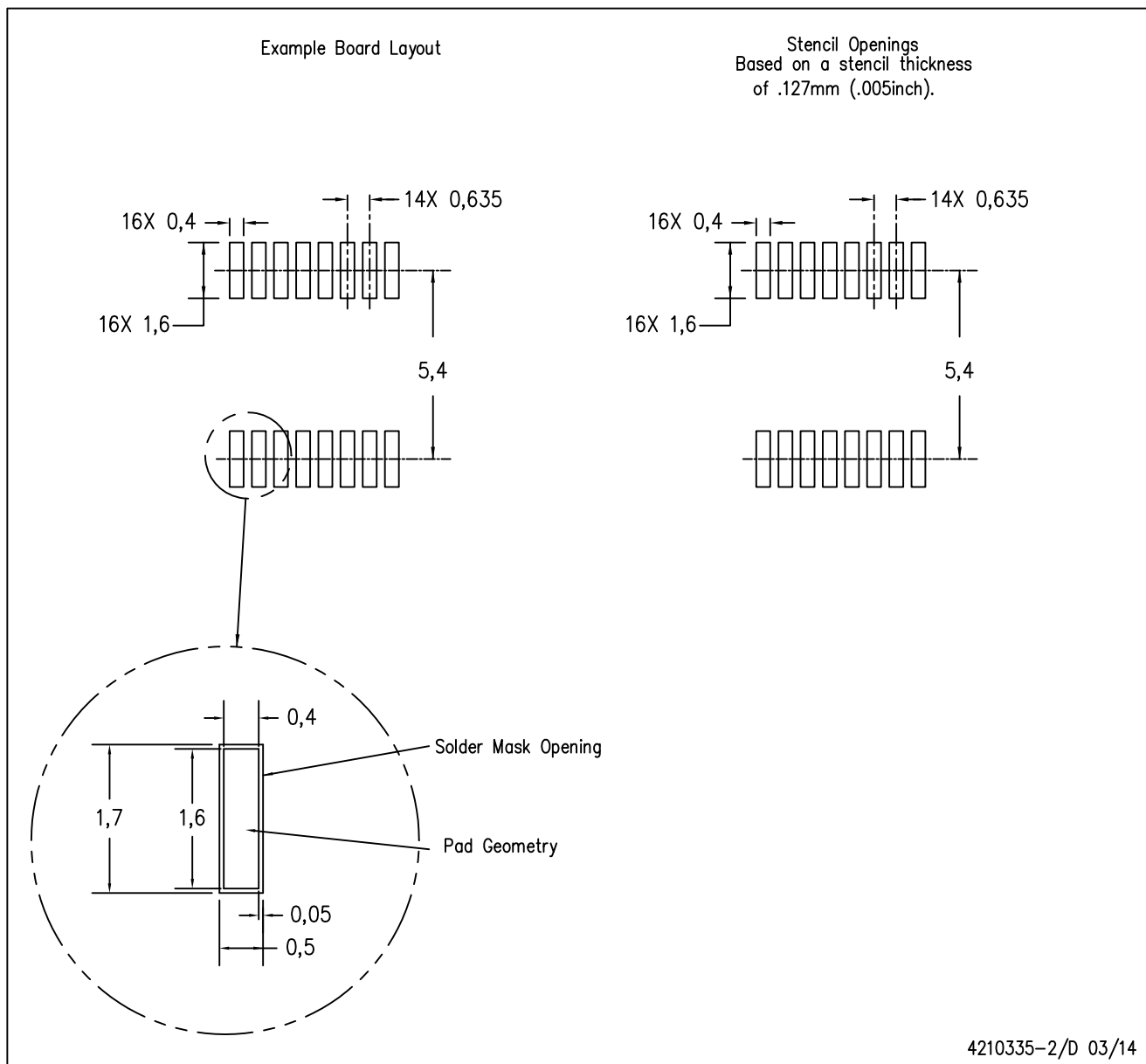

- NOTES:
- A. All linear dimensions are in millimeters.
 - B. This drawing is subject to change without notice.
 - C. Publication IPC-7351 is recommended for alternate designs.
 - D. Laser cutting apertures with trapezoidal walls and also rounding corners will offer better paste release. Customers should contact their board assembly site for stencil design recommendations. Example stencil design based on a 50% volumetric metal load solder paste. Refer to IPC-7525 for other stencil recommendations.

IMPORTANT NOTICE

Texas Instruments Incorporated and its subsidiaries (TI) reserve the right to make corrections, enhancements, improvements and other changes to its semiconductor products and services per JESD46, latest issue, and to discontinue any product or service per JESD48, latest issue. Buyers should obtain the latest relevant information before placing orders and should verify that such information is current and complete. All semiconductor products (also referred to herein as "components") are sold subject to TI's terms and conditions of sale supplied at the time of order acknowledgment.

TI warrants performance of its components to the specifications applicable at the time of sale, in accordance with the warranty in TI's terms and conditions of sale of semiconductor products. Testing and other quality control techniques are used to the extent TI deems necessary to support this warranty. Except where mandated by applicable law, testing of all parameters of each component is not necessarily performed.

TI assumes no liability for applications assistance or the design of Buyers' products. Buyers are responsible for their products and applications using TI components. To minimize the risks associated with Buyers' products and applications, Buyers should provide adequate design and operating safeguards.

TI does not warrant or represent that any license, either express or implied, is granted under any patent right, copyright, mask work right, or other intellectual property right relating to any combination, machine, or process in which TI components or services are used. Information published by TI regarding third-party products or services does not constitute a license to use such products or services or a warranty or endorsement thereof. Use of such information may require a license from a third party under the patents or other intellectual property of the third party, or a license from TI under the patents or other intellectual property of TI.

Reproduction of significant portions of TI information in TI data books or data sheets is permissible only if reproduction is without alteration and is accompanied by all associated warranties, conditions, limitations, and notices. TI is not responsible or liable for such altered documentation. Information of third parties may be subject to additional restrictions.

Resale of TI components or services with statements different from or beyond the parameters stated by TI for that component or service voids all express and any implied warranties for the associated TI component or service and is an unfair and deceptive business practice. TI is not responsible or liable for any such statements.

Buyer acknowledges and agrees that it is solely responsible for compliance with all legal, regulatory and safety-related requirements concerning its products, and any use of TI components in its applications, notwithstanding any applications-related information or support that may be provided by TI. Buyer represents and agrees that it has all the necessary expertise to create and implement safeguards which anticipate dangerous consequences of failures, monitor failures and their consequences, lessen the likelihood of failures that might cause harm and take appropriate remedial actions. Buyer will fully indemnify TI and its representatives against any damages arising out of the use of any TI components in safety-critical applications.

In some cases, TI components may be promoted specifically to facilitate safety-related applications. With such components, TI's goal is to help enable customers to design and create their own end-product solutions that meet applicable functional safety standards and requirements. Nonetheless, such components are subject to these terms.

No TI components are authorized for use in FDA Class III (or similar life-critical medical equipment) unless authorized officers of the parties have executed a special agreement specifically governing such use.

Only those TI components which TI has specifically designated as military grade or "enhanced plastic" are designed and intended for use in military/aerospace applications or environments. Buyer acknowledges and agrees that any military or aerospace use of TI components which have **not** been so designated is solely at the Buyer's risk, and that Buyer is solely responsible for compliance with all legal and regulatory requirements in connection with such use.

TI has specifically designated certain components as meeting ISO/TS16949 requirements, mainly for automotive use. In any case of use of non-designated products, TI will not be responsible for any failure to meet ISO/TS16949.

Products

| | |
|------------------------------|--|
| Audio | www.ti.com/audio |
| Amplifiers | amplifier.ti.com |
| Data Converters | dataconverter.ti.com |
| DLP® Products | www.dlp.com |
| DSP | dsp.ti.com |
| Clocks and Timers | www.ti.com/clocks |
| Interface | interface.ti.com |
| Logic | logic.ti.com |
| Power Mgmt | power.ti.com |
| Microcontrollers | microcontroller.ti.com |
| RFID | www.ti-rfid.com |
| OMAP Applications Processors | www.ti.com/omap |
| Wireless Connectivity | www.ti.com/wirelessconnectivity |

Applications

| | |
|-------------------------------|--|
| Automotive and Transportation | www.ti.com/automotive |
| Communications and Telecom | www.ti.com/communications |
| Computers and Peripherals | www.ti.com/computers |
| Consumer Electronics | www.ti.com/consumer-apps |
| Energy and Lighting | www.ti.com/energy |
| Industrial | www.ti.com/industrial |
| Medical | www.ti.com/medical |
| Security | www.ti.com/security |
| Space, Avionics and Defense | www.ti.com/space-avionics-defense |
| Video and Imaging | www.ti.com/video |

TI E2E Community

e2e.ti.com