

**FEATURES**

- Control Inputs  $V_{IH}/V_{IL}$  Levels Are Referenced to  $V_{CCA}$  Voltage
- $V_{CC}$  Isolation Feature – If Either  $V_{CC}$  Input Is at GND, All I/O Ports Are in the High-Impedance State
- $I_{off}$  Supports Partial-Power-Down Mode Operation
- Fully Configurable Dual-Rail Design Allows Each Port to Operate Over the Full 1.2-V to 3.6-V Power-Supply Range
- I/Os Are 4.6-V Tolerant
- Max Data Rates:
  - 320 Mbps ( $V_{CCA} \geq 1.8\text{ V}$  and  $V_{CCB} \geq 1.8\text{ V}$ )
  - 170 Mbps ( $V_{CCA} \leq 1.8\text{ V}$  or  $V_{CCB} \leq 1.8\text{ V}$ )
- Bus Hold on Data Inputs Eliminates the Need for External Pullup/Pulldown Resistors
- Latch-Up Performance Exceeds 100 mA Per JESD 78, Class II
- ESD Protection Exceeds JESD 22
  - 8000-V Human-Body Model (A114-A)
  - 200-V Machine Model (A115-A)
  - 1000-V Charged-Device Model (C101)

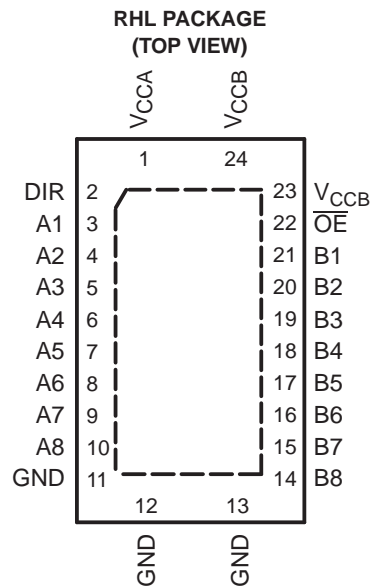
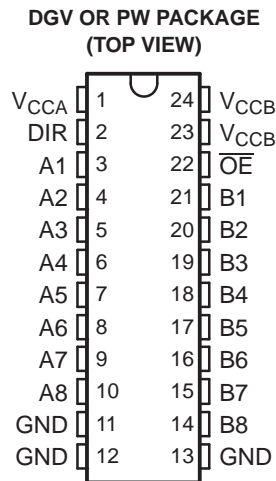

**DESCRIPTION/ORDERING INFORMATION**

This 8-bit noninverting bus transceiver uses two separate configurable power-supply rails. The SN74AVCH8T245 is optimized to operate with  $V_{CCA}/V_{CCB}$  set at 1.4 V to 3.6 V. It is operational with  $V_{CCA}/V_{CCB}$  as low as 1.2 V. The A port is designed to track  $V_{CCA}$ .  $V_{CCA}$  accepts any supply voltage from 1.2 V to 3.6 V. The B port is designed to track  $V_{CCB}$ .  $V_{CCB}$  accepts any supply voltage from 1.2 V to 3.6 V. This allows for universal low-voltage bidirectional translation between any of the 1.2-V, 1.5-V, 1.8-V, 2.5-V, and 3.3-V voltage nodes.

**ORDERING INFORMATION**

$T_A$	PACKAGE <sup>(1)</sup>		ORDERABLE PART NUMBER	TOP-SIDE MARKING
–40°C to 85°C	QFN – RHL	Reel of 1000	SN74AVCH8T245RHLR	WP245
	TSSOP – PW	Tube of 60	SN74AVCH8T245PW	WP245
		Reel of 2000	SN74AVCH8T245PWR	
	TVSOP – DGV	Reel of 2000	SN74AVCH8T245DGVR	WP245

(1) Package drawings, standard packing quantities, thermal data, symbolization, and PCB design guidelines are available at [www.ti.com/sc/package](http://www.ti.com/sc/package).



Please be aware that an important notice concerning availability, standard warranty, and use in critical applications of Texas Instruments semiconductor products and disclaimers thereto appears at the end of this data sheet.

**DESCRIPTION/ORDERING INFORMATION (CONTINUED)**

The SN74AVCH8T245 is designed for asynchronous communication between data buses. The device transmits data from the A bus to the B bus or from the B bus to the A bus, depending on the logic level at the direction-control (DIR) input. The output-enable ( $\overline{OE}$ ) input can be used to disable the outputs so the buses are effectively isolated.

The SN74AVCH8T245 is designed so the control pins (DIR and  $\overline{OE}$ ) are supplied by  $V_{CCA}$ .

The SN74AVCH8T245 solution is compatible with a single-supply system and can be replaced later with a '245 function, with minimal printed circuit board redesign.

This device is fully specified for partial-power-down applications using  $I_{off}$ . The  $I_{off}$  circuitry disables the outputs, preventing damaging current backflow through the device when it is powered down.

The  $V_{CC}$  isolation feature ensures that if either  $V_{CC}$  input is at GND, both outputs are in the high-impedance state. The bus-hold circuitry on the powered-up side always stays active.

Active bus-hold circuitry holds unused or undriven inputs at a valid logic state. Use of pullup or pulldown resistors with the bus-hold circuitry is not recommended.

To ensure the high-impedance state during power up or power down,  $\overline{OE}$  shall be tied to  $V_{CC}$  through a pullup resistor; the minimum value of the resistor is determined by the current-sinking capability of the driver.

**FUNCTION TABLE**  
**(each 8-bit section)**

INPUTS		OPERATION
$\overline{OE}$	DIR	
L	L	B data to A bus
L	H	A data to B bus
H	X	All output Hi-Z

**LOGIC DIAGRAM (POSITIVE LOGIC)**

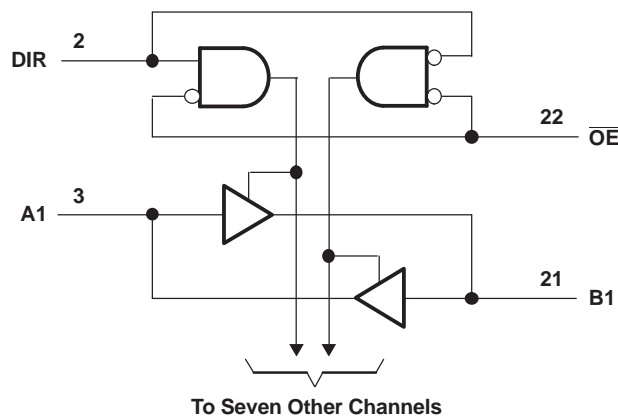

### Absolute Maximum Ratings<sup>(1)</sup>

over operating free-air temperature range (unless otherwise noted)

		MIN	MAX	UNIT	
$V_{CCA}$ $V_{CCB}$	Supply voltage range	–0.5	4.6	V	
$V_I$	Input voltage range <sup>(2)</sup>	I/O ports (A port)	–0.5	4.6	V
		I/O ports (B port)	–0.5	4.6	
		Control inputs	–0.5	4.6	
$V_O$	Voltage range applied to any output in the high-impedance or power-off state <sup>(2)</sup>	A port	–0.5	4.6	V
		B port	–0.5	4.6	
$V_O$	Voltage range applied to any output in the high or low state <sup>(2)(3)</sup>	A port	–0.5	$V_{CCA} + 0.5$	V
		B port	–0.5	$V_{CCB} + 0.5$	
$I_{IK}$	Input clamp current	$V_I < 0$	–50	mA	
$I_{OK}$	Output clamp current	$V_O < 0$	–50	mA	
$I_O$	Continuous output current		±50	mA	
	Continuous current through $V_{CCA}$ , $V_{CCB}$ , or GND		±100	mA	
$\theta_{JA}$	Package thermal impedance <sup>(4)</sup>	DGV package	86	°C/W	
		PW package	88		
		RHL package	43		
$T_{stg}$	Storage temperature range	–65	150	°C	

- (1) Stresses beyond those listed under "absolute maximum ratings" may cause permanent damage to the device. These are stress ratings only, and functional operation of the device at these or any other conditions beyond those indicated under "recommended operating conditions" is not implied. Exposure to absolute-maximum-rated conditions for extended periods may affect device reliability.
- (2) The input voltage and output negative-voltage ratings may be exceeded if the input and output current ratings are observed.
- (3) The output positive-voltage rating may be exceeded up to 4.6 V maximum if the output current rating is observed.
- (4) The package thermal impedance is calculated in accordance with JESD 51-7.

Recommended Operating Conditions<sup>(1)(2)(3)</sup>

		$V_{CCI}$	$V_{CCO}$	MIN	MAX	UNIT
$V_{CCA}$	Supply voltage			1.2	3.6	V
$V_{CCB}$	Supply voltage			1.2	3.6	V
$V_{IH}$	High-level input voltage	Data inputs	1.2 V to 1.95 V	$V_{CCI} \times 0.65$		V
			1.95 V to 2.7 V	1.6		
			2.7 V to 3.6 V	2		
$V_{IL}$	Low-level input voltage	Data inputs	1.2 V to 1.95 V	$V_{CCI} \times 0.35$		V
			1.95 V to 2.7 V	0.7		
			2.7 V to 3.6 V	0.8		
$V_{IH}$	High-level input voltage	DIR (referenced to $V_{CCA}$ )	1.2 V to 1.95 V	$V_{CCA} \times 0.65$		V
			1.95 V to 2.7 V	1.6		
			2.7 V to 3.6 V	2		
$V_{IL}$	Low-level input voltage	DIR (referenced to $V_{CCA}$ )	1.2 V to 1.95 V	$V_{CCA} \times 0.35$		V
			1.95 V to 2.7 V	0.7		
			2.7 V to 3.6 V	0.8		
$V_I$	Input voltage			0	3.6	V
$V_O$	Output voltage	Active state		0	$V_{CCO}$	V
		3-state		0	3.6	
$I_{OH}$	High-level output current		1.2 V		–3	mA
			1.4 V to 1.6 V		–6	
			1.65 V to 1.95 V		–8	
			2.3 V to 2.7 V		–9	
			3 V to 3.6 V		–12	
$I_{OL}$	Low-level output current		1.2 V		3	mA
			1.4 V to 1.6 V		6	
			1.65 V to 1.95 V		8	
			2.3 V to 2.7 V		9	
			3 V to 3.6 V		12	
$\Delta t/\Delta v$	Input transition rise or fall rate				5	ns/V
$T_A$	Operating free-air temperature			–40	85	°C

(1)  $V_{CCI}$  is the  $V_{CC}$  associated with the input port.

(2)  $V_{CCO}$  is the  $V_{CC}$  associated with the output port.

(3) All unused data inputs of the device must be held at  $V_{CCI}$  or GND to ensure proper device operation. Refer to the TI application report, *Implications of Slow or Floating CMOS Inputs*, literature number SCBA004.

**Electrical Characteristics**<sup>(1)(2)</sup>

over recommended operating free-air temperature range (unless otherwise noted)

PARAMETER	TEST CONDITIONS		V <sub>CCA</sub>	V <sub>CCB</sub>	T <sub>A</sub> = 25°C			–40°C to 85°C		UNIT
					MIN	TYP	MAX	MIN	MAX	
V <sub>OH</sub>	I <sub>OH</sub> = –100 μA	V <sub>I</sub> = V <sub>IH</sub>	1.2 V to 3.6 V	1.2 V to 3.6 V				V <sub>CCO</sub> – 0.2		V
	I <sub>OH</sub> = –3 mA		1.2 V	1.2 V	0.95					
	I <sub>OH</sub> = –6 mA		1.4 V	1.4 V				1.05		
	I <sub>OH</sub> = –8 mA		1.65 V	1.65 V				1.2		
	I <sub>OH</sub> = –9 mA		2.3 V	2.3 V				1.75		
	I <sub>OH</sub> = –12 mA		3 V	3 V				2.3		
V <sub>OL</sub>	I <sub>OL</sub> = 100 μA	V <sub>I</sub> = V <sub>IL</sub>	1.2 V to 3.6 V	1.2 V to 3.6 V				0.2		V
	I <sub>OL</sub> = 3 mA		1.2 V	1.2 V	0.15					
	I <sub>OL</sub> = 6 mA		1.4 V	1.4 V				0.35		
	I <sub>OL</sub> = 8 mA		1.65 V	1.65 V				0.45		
	I <sub>OL</sub> = 9 mA		2.3 V	2.3 V				0.55		
	I <sub>OL</sub> = 12 mA		3 V	3 V				0.7		
I <sub>I</sub>	Control inputs	V <sub>I</sub> = V <sub>CCA</sub> or GND	1.2 V to 3.6 V	1.2 V to 3.6 V		±0.025	±0.25		±1	μA
I <sub>BHL</sub> <sup>(3)</sup>	V <sub>I</sub> = 0.42 V		1.2 V	1.2 V		25				μA
	V <sub>I</sub> = 0.49 V		1.4 V	1.4 V				15		
	V <sub>I</sub> = 0.58 V		1.65 V	1.65 V				25		
	V <sub>I</sub> = 0.7 V		2.3 V	2.3 V				45		
	V <sub>I</sub> = 0.8 V		3.3 V	3.3 V				100		
I <sub>BHH</sub> <sup>(4)</sup>	V <sub>I</sub> = 0.78 V		1.2 V	1.2 V		–25				μA
	V <sub>I</sub> = 0.91 V		1.4 V	1.4 V				–15		
	V <sub>I</sub> = 1.07 V		1.65 V	1.65 V				–25		
	V <sub>I</sub> = 1.6 V		2.3 V	2.3 V				–45		
	V <sub>I</sub> = 2 V		3.3 V	3.3 V				–100		
I <sub>BHLO</sub> <sup>(5)</sup>	V <sub>I</sub> = 0 to V <sub>CC</sub>		1.2 V	1.2 V		50				μA
			1.6 V	1.6 V				125		
			1.95 V	1.95 V				200		
			2.7 V	2.7 V				300		
			3.6 V	3.6 V				500		
I <sub>BHHO</sub> <sup>(6)</sup>	V <sub>I</sub> = 0 to V <sub>CC</sub>		1.2 V	1.2 V		–50				μA
			1.6 V	1.6 V				–125		
			1.95 V	1.95 V				–200		
			2.7 V	2.7 V				–300		
			3.6 V	3.6 V				–500		

 (1) V<sub>CCI</sub> is the V<sub>CC</sub> associated with the input port.

 (2) V<sub>CCO</sub> is the V<sub>CC</sub> associated with the output port.

 (3) The bus-hold circuit can sink at least the minimum low sustaining current at V<sub>IL</sub> max. I<sub>BHL</sub> should be measured after lowering V<sub>IN</sub> to GND and then raising it to V<sub>IL</sub> max.

 (4) The bus-hold circuit can source at least the minimum high sustaining current at V<sub>IH</sub> min. I<sub>BHH</sub> should be measured after raising V<sub>IN</sub> to V<sub>CC</sub> and then lowering it to V<sub>IH</sub> min.

 (5) An external driver must source at least I<sub>BHLO</sub> to switch this node from low to high.

 (6) An external driver must sink at least I<sub>BHHO</sub> to switch this node from high to low.

**Electrical Characteristics (continued)**<sup>(1)(2)</sup>

over recommended operating free-air temperature range (unless otherwise noted)

PARAMETER	TEST CONDITIONS	V <sub>CCA</sub>	V <sub>CCB</sub>	T <sub>A</sub> = 25°C			–40°C to 85°C		UNIT
				MIN	TYP	MAX	MIN	MAX	
I <sub>off</sub>	A port	V <sub>I</sub> or V <sub>O</sub> = 0 to 3.6 V	0 V	0 V to 3.6 V	±0.1	±1	±5		μA
	B port		0 V to 3.6 V	0 V	±0.1	±1	±5		
I <sub>OZ</sub> <sup>(3)</sup>	A or B port	V <sub>O</sub> = V <sub>CCO</sub> or GND, V <sub>I</sub> = V <sub>CCI</sub> or GND, OE = V <sub>IH</sub>	3.6 V	3.6 V	±0.5	±2.5	±5		μA
	B port	V <sub>O</sub> = V <sub>CCO</sub> or GND, V <sub>I</sub> = V <sub>CCI</sub> or GND, OE = don't care	0 V	3.6 V			±5		
	A port	V <sub>O</sub> = V <sub>CCO</sub> or GND, V <sub>I</sub> = V <sub>CCI</sub> or GND, OE = don't care	3.6 V	0 V			±5		
I <sub>CCA</sub>	V <sub>I</sub> = V <sub>CCI</sub> or GND, I <sub>O</sub> = 0	1.2 V to 3.6 V	1.2 V to 3.6 V			8		μA	
		0 V	3.6 V			–2			
		3.6 V	0 V			8			
I <sub>CCB</sub>	V <sub>I</sub> = V <sub>CCI</sub> or GND, I <sub>O</sub> = 0	1.2 V to 3.6 V	1.2 V to 3.6 V			8		μA	
		0 V	3.6 V			8			
		3.6 V	0 V			–2			
I <sub>CCA</sub> + I <sub>CCB</sub>	V <sub>I</sub> = V <sub>CCI</sub> or GND, I <sub>O</sub> = 0	1.2 V to 3.6 V	1.2 V to 3.6 V			16		μA	
C <sub>i</sub>	Control inputs	V <sub>I</sub> = 3.3 V or GND	3.3 V	3.3 V	3.5		4.5		pF
C <sub>io</sub>	A or B port	V <sub>O</sub> = 3.3 V or GND	3.3 V	3.3 V	6		7		pF

(1) V<sub>CCI</sub> is the V<sub>CC</sub> associated with the input port.(2) V<sub>CCO</sub> is the V<sub>CC</sub> associated with the output port.(3) For I/O ports, the parameter I<sub>OZ</sub> includes the input leakage current.**Switching Characteristics**over recommended operating free-air temperature range, V<sub>CCA</sub> = 1.2 V (see Figure 10)

PARAMETER	FROM (INPUT)	TO (OUTPUT)	V <sub>CCB</sub> = 1.2 V	V <sub>CCB</sub> = 1.5 V	V <sub>CCB</sub> = 1.8 V	V <sub>CCB</sub> = 2.5 V	V <sub>CCB</sub> = 3.3 V	UNIT
			TYP	TYP	TYP	TYP	TYP	
t <sub>PLH</sub>	A	B	3.1	2.6	2.5	3	3.5	ns
t <sub>PHL</sub>			3.1	2.6	2.5	3	3.5	
t <sub>PLH</sub>	B	A	3.1	2.7	2.5	2.4	2.3	ns
t <sub>PHL</sub>			3.1	2.7	2.5	2.4	2.3	
t <sub>PZH</sub>	OE	A	5.3	5.3	5.3	5.3	5.3	ns
t <sub>PZL</sub>			5.3	5.3	5.3	5.3	5.3	
t <sub>PZH</sub>	OE	B	5.1	4	3.5	3.2	3.1	ns
t <sub>PZL</sub>			5.1	4	3.5	3.2	3.1	
t <sub>PHZ</sub>	OE	A	4.8	4.8	4.8	4.8	4.8	ns
t <sub>PLZ</sub>			4.8	4.8	4.8	4.8	4.8	
t <sub>PHZ</sub>	OE	B	4.7	4	4.1	4.3	5.1	ns
t <sub>PLZ</sub>			4.7	4	4.1	4.3	5.1	

### Switching Characteristics

over recommended operating free-air temperature range,  $V_{CCA} = 1.5\text{ V} \pm 0.1\text{ V}$  (see [Figure 10](#))

PARAMETER	FROM (INPUT)	TO (OUTPUT)	$V_{CCB} = 1.2\text{ V}$	$V_{CCB} = 1.5\text{ V} \pm 0.1\text{ V}$		$V_{CCB} = 1.8\text{ V} \pm 0.15\text{ V}$		$V_{CCB} = 2.5\text{ V} \pm 0.2\text{ V}$		$V_{CCB} = 3.3\text{ V} \pm 0.3\text{ V}$		UNIT
			TYP	MIN	MAX	MIN	MAX	MIN	MAX	MIN	MAX	
$t_{PLH}$	A	B	2.7	0.5	5.4	0.5	4.6	0.5	4.9	0.5	6.8	ns
$t_{PHL}$			2.7	0.5	5.4	0.5	4.6	0.5	4.9	0.5	6.8	
$t_{PLH}$	B	A	2.6	0.5	5.4	0.5	5.1	0.5	4.7	0.5	4.5	ns
$t_{PHL}$			2.6	0.5	5.4	0.5	5.1	0.5	4.7	0.5	4.5	
$t_{PZH}$	$\overline{OE}$	A	3.7	1.1	8.7	1.1	8.7	1.1	8.7	1.1	8.7	ns
$t_{PZL}$			3.7	1.1	8.7	1.1	8.7	1.1	8.7	1.1	8.7	
$t_{PZH}$	$\overline{OE}$	B	4.8	1.1	7.6	1.1	7.1	1	5.6	1	5.2	ns
$t_{PZL}$			4.8	1.1	7.6	1.1	7.1	1	5.6	1	5.2	
$t_{PHZ}$	$\overline{OE}$	A	3.1	0.5	8.6	0.5	8.6	0.5	8.6	0.5	8.6	ns
$t_{PLZ}$			3.1	0.5	8.6	0.5	8.6	0.5	8.6	0.5	8.6	
$t_{PHZ}$	$\overline{OE}$	B	4.1	0.5	8.4	0.5	7.6	0.5	7.2	0.5	7.8	ns
$t_{PLZ}$			4.1	0.5	8.4	0.5	7.6	0.5	7.2	0.5	7.8	

### Switching Characteristics

over recommended operating free-air temperature range,  $V_{CCA} = 1.8\text{ V} \pm 0.15\text{ V}$  (see [Figure 10](#))

PARAMETER	FROM (INPUT)	TO (OUTPUT)	$V_{CCB} = 1.2\text{ V}$	$V_{CCB} = 1.5\text{ V} \pm 0.1\text{ V}$		$V_{CCB} = 1.8\text{ V} \pm 0.15\text{ V}$		$V_{CCB} = 2.5\text{ V} \pm 0.2\text{ V}$		$V_{CCB} = 3.3\text{ V} \pm 0.3\text{ V}$		UNIT
			TYP	MIN	MAX	MIN	MAX	MIN	MAX	MIN	MAX	
$t_{PLH}$	A	B	2.5	0.5	5.1	0.5	4.4	0.5	4	0.5	3.9	ns
$t_{PHL}$			2.5	0.5	5.1	0.5	4.4	0.5	4	0.5	3.9	
$t_{PLH}$	B	A	2.5	0.5	4.6	0.5	4.4	0.5	3.9	0.5	3.7	ns
$t_{PHL}$			2.5	0.5	4.6	0.5	4.4	0.5	3.9	0.5	3.7	
$t_{PZH}$	$\overline{OE}$	A	3	1	6.8	1	6.8	1	6.8	1	6.8	ns
$t_{PZL}$			3	1	6.8	1	6.8	1	6.8	1	6.8	
$t_{PZH}$	$\overline{OE}$	B	4.6	1.1	8.2	1	6.7	0.5	5.1	0.5	4.5	ns
$t_{PZL}$			4.6	1.1	8.2	1	6.7	0.5	5.1	0.5	4.5	
$t_{PHZ}$	$\overline{OE}$	A	2.8	0.5	7.1	0.5	7.1	0.5	7.1	0.5	7.1	ns
$t_{PLZ}$			2.8	0.5	7.1	0.5	7.1	0.5	7.1	0.5	7.1	
$t_{PHZ}$	$\overline{OE}$	B	3.9	0.5	7.8	0.5	6.9	0.5	6	0.5	5.8	ns
$t_{PLZ}$			3.9	0.5	7.8	0.5	6.9	0.5	6	0.5	5.8	

**Switching Characteristics**over recommended operating free-air temperature range,  $V_{CCA} = 2.5\text{ V} \pm 0.2\text{ V}$  (see Figure 10)

PARAMETER	FROM (INPUT)	TO (OUTPUT)	$V_{CCB} = 1.2\text{ V}$	$V_{CCB} = 1.5\text{ V} \pm 0.1\text{ V}$		$V_{CCB} = 1.8\text{ V} \pm 0.15\text{ V}$		$V_{CCB} = 2.5\text{ V} \pm 0.2\text{ V}$		$V_{CCB} = 3.3\text{ V} \pm 0.3\text{ V}$		UNIT
			TYP	MIN	MAX	MIN	MAX	MIN	MAX	MIN	MAX	
$t_{PLH}$	A	B	2.4	0.5	4.7	0.5	3.9	0.5	3.1	0.5	2.8	ns
$t_{PHL}$			2.4	0.5	4.7	0.5	3.9	0.5	3.1	0.5	2.8	
$t_{PLH}$	B	A	3	0.5	4.9	0.5	4	0.5	3.1	0.5	2.9	ns
$t_{PHL}$			3	0.5	4.9	0.5	4	0.5	3.1	0.5	2.9	
$t_{PZH}$	$\overline{OE}$	A	2.2	0.5	4.8	0.5	4.8	0.5	4.8	0.5	4.8	ns
$t_{PZL}$			2.2	0.5	4.8	0.5	4.8	0.5	4.8	0.5	4.8	
$t_{PZH}$	$\overline{OE}$	B	4.5	1.1	7.9	0.5	6.4	0.5	4.6	0.5	4	ns
$t_{PZL}$			4.5	1.1	7.9	0.5	6.4	0.5	4.6	0.5	4	
$t_{PHZ}$	$\overline{OE}$	A	1.8	0.5	5.1	0.5	5.1	0.5	5.1	0.5	5.1	ns
$t_{PLZ}$			1.8	0.5	5.1	0.5	5.1	0.5	5.1	0.5	5.1	
$t_{PHZ}$	$\overline{OE}$	B	3.6	0.5	7.1	0.5	6.3	0.5	5.1	0.5	3.9	ns
$t_{PLZ}$			3.6	0.5	7.1	0.5	6.3	0.5	5.1	0.5	3.9	

**Switching Characteristics**over recommended operating free-air temperature range,  $V_{CCA} = 3.3\text{ V} \pm 0.3\text{ V}$  (see Figure 10)

PARAMETER	FROM (INPUT)	TO (OUTPUT)	$V_{CCB} = 1.2\text{ V}$	$V_{CCB} = 1.5\text{ V} \pm 0.1\text{ V}$		$V_{CCB} = 1.8\text{ V} \pm 0.15\text{ V}$		$V_{CCB} = 2.5\text{ V} \pm 0.2\text{ V}$		$V_{CCB} = 3.3\text{ V} \pm 0.3\text{ V}$		UNIT
			TYP	MIN	MAX	MIN	MAX	MIN	MAX	MIN	MAX	
$t_{PLH}$	A	B	2.3	0.5	4.5	0.5	3.7	0.5	2.9	0.5	2.5	ns
$t_{PHL}$			2.3	0.5	4.5	0.5	3.3	0.5	2.9	0.5	2.5	
$t_{PLH}$	B	A	3.5	0.5	6.8	0.5	3.9	0.5	2.8	0.5	2.5	ns
$t_{PHL}$			3.5	0.5	6.8	0.5	3.9	0.5	2.8	0.5	2.5	
$t_{PZH}$	$\overline{OE}$	A	2	0.5	4	0.5	4	0.5	4	0.5	4	ns
$t_{PZL}$			2	0.5	4	0.5	4	0.5	4	0.5	4	
$t_{PZH}$	$\overline{OE}$	B	4.5	1.1	7.8	0.5	6.2	0.5	4.5	0.5	3.9	ns
$t_{PZL}$			4.5	1.1	7.8	0.5	6.2	0.5	4.5	0.5	3.9	
$t_{PHZ}$	$\overline{OE}$	A	1.7	0.5	4	0.5	4	0.5	4	0.5	4	ns
$t_{PLZ}$			1.7	0.5	4	0.5	4	0.5	4	0.5	4	
$t_{PHZ}$	$\overline{OE}$	B	3.4	0.5	6.9	0.5	6	0.5	4.8	0.5	4.2	ns
$t_{PLZ}$			3.4	0.5	6.9	0.5	6	0.5	4.8	0.5	4.2	



## Operating Characteristics

$T_A = 25^\circ\text{C}$

PARAMETER			TEST CONDITIONS	$V_{CCA} =$ $V_{CCB} = 1.2\text{ V}$	$V_{CCA} =$ $V_{CCB} = 1.5\text{ V}$	$V_{CCA} =$ $V_{CCB} = 1.8\text{ V}$	$V_{CCA} =$ $V_{CCB} = 2.5\text{ V}$	$V_{CCA} =$ $V_{CCB} = 3.3\text{ V}$	UNIT
				TYP	TYP	TYP	TYP	TYP	
$C_{pdA}^{(1)}$	A to B	Outputs enabled	$C_L = 0,$ $f = 10\text{ MHz},$ $t_r = t_f = 1\text{ ns}$	1	1	1	1	1	pF
		Outputs disabled		1	1	1	1	1	
	B to A	Outputs enabled		12	12	12	13	14	
		Outputs disabled		1	1	1	1	1	
$C_{pdB}^{(1)}$	A to B	Outputs enabled	$C_L = 0,$ $f = 10\text{ MHz},$ $t_r = t_f = 1\text{ ns}$	12	12	12	13	14	pF
		Outputs disabled		1	1	1	1	1	
	B to A	Outputs enabled		1	1	1	1	1	
		Outputs disabled		1	1	1	1	1	

(1) Power dissipation capacitance per transceiver

**Table 1. Typical Total Static Power Consumption ( $I_{CCA} + I_{CCB}$ )**

$V_{CCB}$	$V_{CCA}$						UNIT
	0 V	1.2 V	1.5 V	1.8 V	2.5 V	3.3 V	
0 V	0	<0.5	<0.5	<0.5	<0.5	<0.5	$\mu\text{A}$
1.2 V	<0.5	<1	<1	<1	<1	1	
1.5 V	<0.5	<1	<1	<1	<1	1	
1.8 V	<0.5	<1	<1	<1	<1	<1	
2.5 V	<0.5	1	<1	<1	<1	<1	
3.3 V	<0.5	1	<1	<1	<1	<1	

TYPICAL CHARACTERISTICS

Typical Propagation Delay (A to B) vs Load Capacitance  
 $T_A = 25^\circ\text{C}$ ,  $V_{CCA} = 1.2\text{ V}$

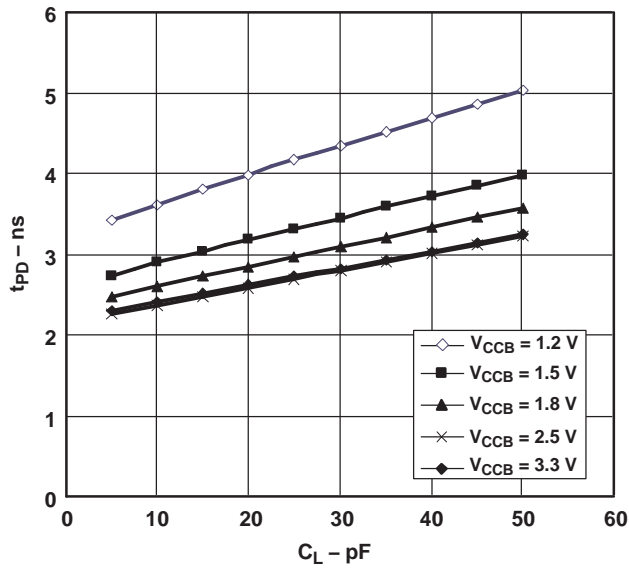

Figure 1.

Typical Propagation Delay (A to B) vs Load Capacitance  
 $T_A = 25^\circ\text{C}$ ,  $V_{CCA} = 1.5\text{ V}$

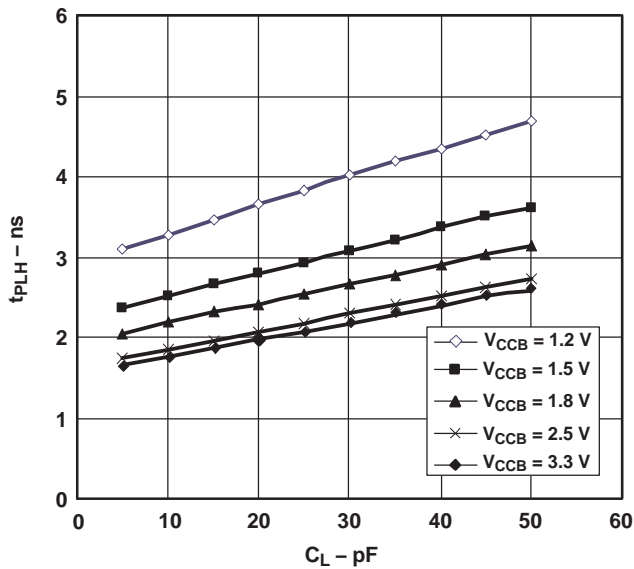

Figure 2.

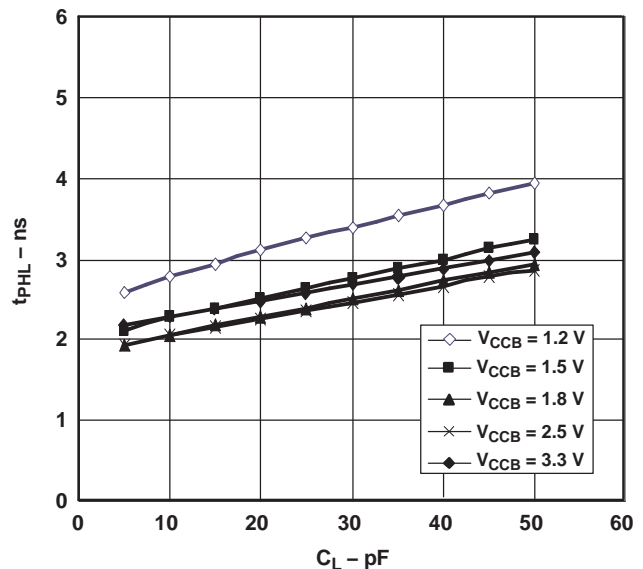

Figure 3.

**TYPICAL CHARACTERISTICS (continued)**

**Typical Propagation Delay (A to B) vs Load Capacitance**  
 $T_A = 25^\circ\text{C}$ ,  $V_{CCA} = 1.8\text{ V}$

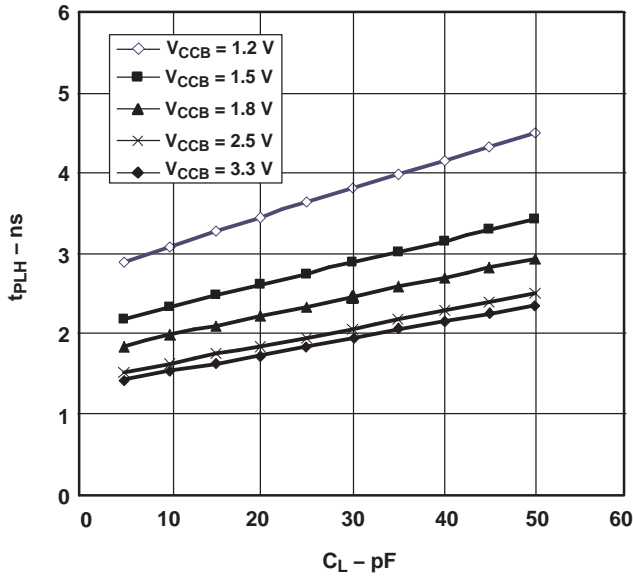

Figure 4.

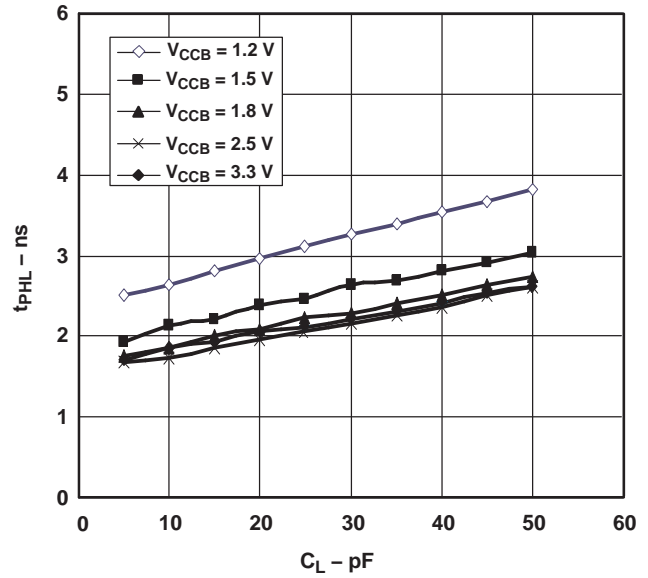

Figure 5.

**Typical Propagation Delay (A to B) vs Load Capacitance**  
 $T_A = 25^\circ\text{C}$ ,  $V_{CCA} = 2.5\text{ V}$

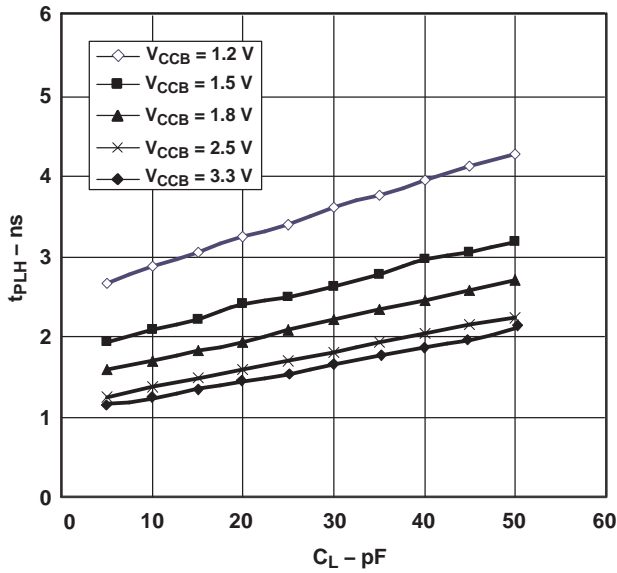

Figure 6.

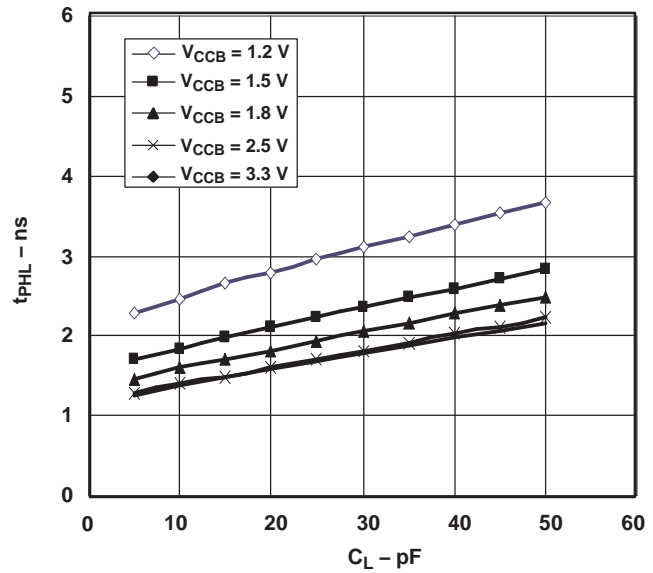

Figure 7.

TYPICAL CHARACTERISTICS (continued)

Typical Propagation Delay (A to B) vs Load Capacitance  
 $T_A = 25^\circ\text{C}$ ,  $V_{CCA} = 3.3\text{ V}$

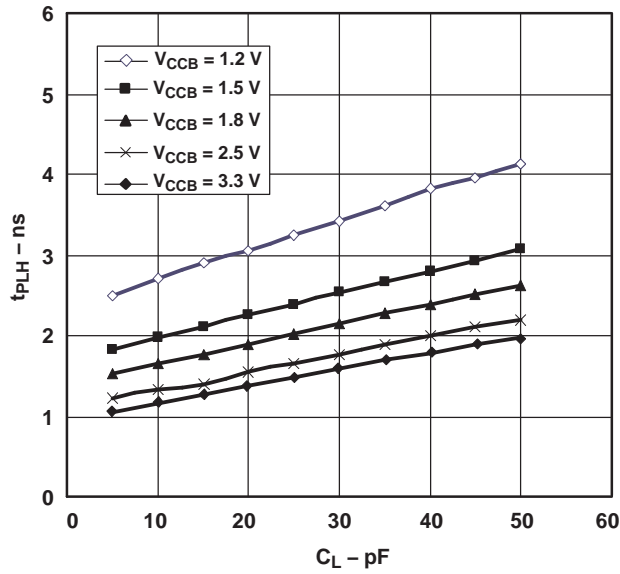

Figure 8.

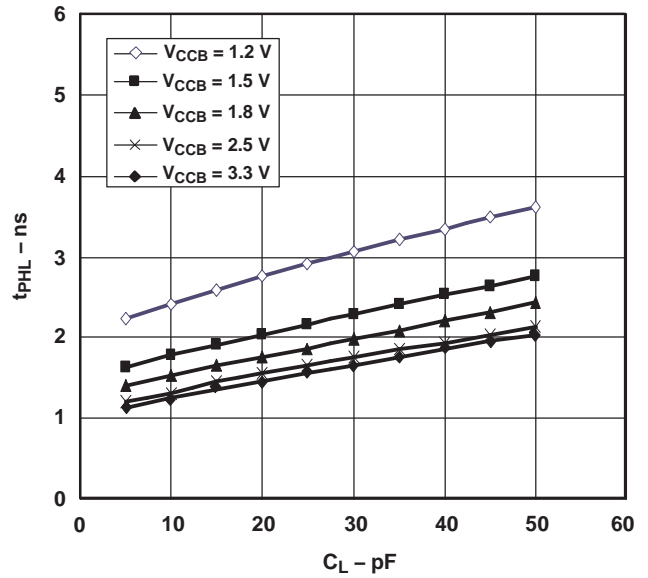
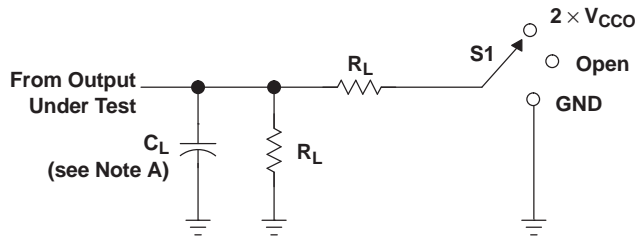

Figure 9.

PARAMETER MEASUREMENT INFORMATION



LOAD CIRCUIT

TEST	S1
$t_{pd}$	Open
$t_{PLZ}/t_{PZL}$	$2 \times V_{CCO}$
$t_{PHZ}/t_{PZH}$	GND

$V_{CCO}$	$C_L$	$R_L$	$V_{TP}$
1.2 V	15 pF	2 k $\Omega$	0.1 V
1.5 V $\pm$ 0.1 V	15 pF	2 k $\Omega$	0.1 V
1.8 V $\pm$ 0.15 V	15 pF	2 k $\Omega$	0.15 V
2.5 V $\pm$ 0.2 V	15 pF	2 k $\Omega$	0.15 V
3.3 V $\pm$ 0.3 V	15 pF	2 k $\Omega$	0.3 V

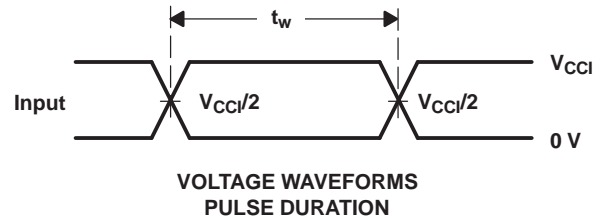

VOLTAGE WAVEFORMS  
PULSE DURATION

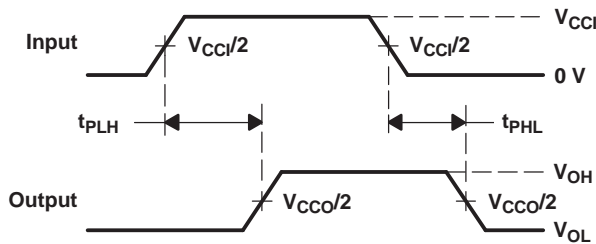

VOLTAGE WAVEFORMS  
PROPAGATION DELAY TIMES

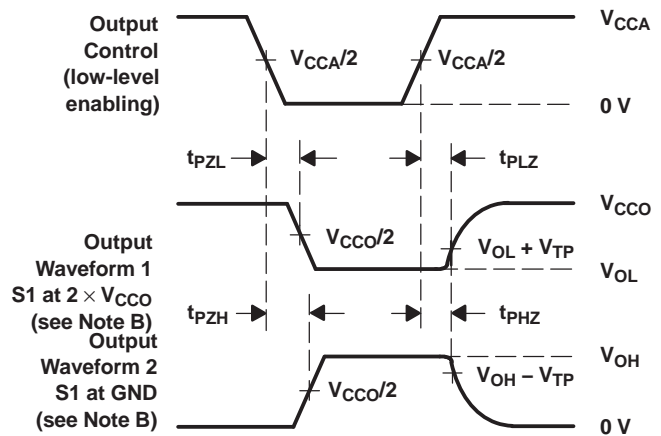

VOLTAGE WAVEFORMS  
ENABLE AND DISABLE TIMES

- NOTES: A.  $C_L$  includes probe and jig capacitance.  
 B. Waveform 1 is for an output with internal conditions such that the output is low, except when disabled by the output control. Waveform 2 is for an output with internal conditions such that the output is high, except when disabled by the output control.  
 C. All input pulses are supplied by generators having the following characteristics:  $PRR \leq 10$  MHz,  $Z_O = 50 \Omega$ ,  $dv/dt \geq 1$  V/ns.  
 D. The outputs are measured one at a time, with one transition per measurement.  
 E.  $t_{PLZ}$  and  $t_{PHZ}$  are the same as  $t_{dis}$ .  
 F.  $t_{PZL}$  and  $t_{PZH}$  are the same as  $t_{en}$ .  
 G.  $t_{PLH}$  and  $t_{PHL}$  are the same as  $t_{pd}$ .  
 H.  $V_{CCi}$  is the  $V_{CC}$  associated with the input port.  
 I.  $V_{CCO}$  is the  $V_{CC}$  associated with the output port.

Figure 10. Load Circuit and Voltage Waveforms

**PACKAGING INFORMATION**

Orderable Device	Status <sup>(1)</sup>	Package Type	Package Drawing	Pins	Package Qty	Eco Plan <sup>(2)</sup>	Lead/Ball Finish	MSL Peak Temp <sup>(3)</sup>
74AVCH8T245DGVRE4	ACTIVE	TVSOP	DGV	24	2000	Green (RoHS & no Sb/Br)	CU NIPDAU	Level-1-260C-UNLIM
74AVCH8T245DGVRG4	ACTIVE	TVSOP	DGV	24	2000	Green (RoHS & no Sb/Br)	CU NIPDAU	Level-1-260C-UNLIM
74AVCH8T245PWRE4	ACTIVE	TSSOP	PW	24	2000	Green (RoHS & no Sb/Br)	CU NIPDAU	Level-1-260C-UNLIM
74AVCH8T245PWRG4	ACTIVE	TSSOP	PW	24	2000	Green (RoHS & no Sb/Br)	CU NIPDAU	Level-1-260C-UNLIM
74AVCH8T245RHLRG4	ACTIVE	QFN	RHL	24	1000	Green (RoHS & no Sb/Br)	CU NIPDAU	Level-2-260C-1 YEAR
SN74AVCH8T245DGVR	ACTIVE	TVSOP	DGV	24	2000	Green (RoHS & no Sb/Br)	CU NIPDAU	Level-1-260C-UNLIM
SN74AVCH8T245PW	ACTIVE	TSSOP	PW	24	60	Green (RoHS & no Sb/Br)	CU NIPDAU	Level-1-260C-UNLIM
SN74AVCH8T245PWE4	ACTIVE	TSSOP	PW	24	60	Green (RoHS & no Sb/Br)	CU NIPDAU	Level-1-260C-UNLIM
SN74AVCH8T245PWG4	ACTIVE	TSSOP	PW	24	60	Green (RoHS & no Sb/Br)	CU NIPDAU	Level-1-260C-UNLIM
SN74AVCH8T245PWR	ACTIVE	TSSOP	PW	24	2000	Green (RoHS & no Sb/Br)	CU NIPDAU	Level-1-260C-UNLIM
SN74AVCH8T245RHLR	ACTIVE	QFN	RHL	24	1000	Green (RoHS & no Sb/Br)	CU NIPDAU	Level-2-260C-1 YEAR

<sup>(1)</sup> The marketing status values are defined as follows:

**ACTIVE:** Product device recommended for new designs.

**LIFEBUY:** TI has announced that the device will be discontinued, and a lifetime-buy period is in effect.

**NRND:** Not recommended for new designs. Device is in production to support existing customers, but TI does not recommend using this part in a new design.

**PREVIEW:** Device has been announced but is not in production. Samples may or may not be available.

**OBSOLETE:** TI has discontinued the production of the device.

<sup>(2)</sup> Eco Plan - The planned eco-friendly classification: Pb-Free (RoHS), Pb-Free (RoHS Exempt), or Green (RoHS & no Sb/Br) - please check <http://www.ti.com/productcontent> for the latest availability information and additional product content details.

**TBD:** The Pb-Free/Green conversion plan has not been defined.

**Pb-Free (RoHS):** TI's terms "Lead-Free" or "Pb-Free" mean semiconductor products that are compatible with the current RoHS requirements for all 6 substances, including the requirement that lead not exceed 0.1% by weight in homogeneous materials. Where designed to be soldered at high temperatures, TI Pb-Free products are suitable for use in specified lead-free processes.

**Pb-Free (RoHS Exempt):** This component has a RoHS exemption for either 1) lead-based flip-chip solder bumps used between the die and package, or 2) lead-based die adhesive used between the die and leadframe. The component is otherwise considered Pb-Free (RoHS compatible) as defined above.

**Green (RoHS & no Sb/Br):** TI defines "Green" to mean Pb-Free (RoHS compatible), and free of Bromine (Br) and Antimony (Sb) based flame retardants (Br or Sb do not exceed 0.1% by weight in homogeneous material)

<sup>(3)</sup> MSL, Peak Temp. -- The Moisture Sensitivity Level rating according to the JEDEC industry standard classifications, and peak solder temperature.

**Important Information and Disclaimer:** The information provided on this page represents TI's knowledge and belief as of the date that it is provided. TI bases its knowledge and belief on information provided by third parties, and makes no representation or warranty as to the accuracy of such information. Efforts are underway to better integrate information from third parties. TI has taken and continues to take reasonable steps to provide representative and accurate information but may not have conducted destructive testing or chemical analysis on incoming materials and chemicals. TI and TI suppliers consider certain information to be proprietary, and thus CAS numbers and other limited information may not be available for release.

In no event shall TI's liability arising out of such information exceed the total purchase price of the TI part(s) at issue in this document sold by TI

to Customer on an annual basis.

**TAPE AND REEL INFORMATION**

**QUADRANT ASSIGNMENTS FOR PIN 1 ORIENTATION IN TAPE**

\*All dimensions are nominal

Device	Package Type	Package Drawing	Pins	SPQ	Reel Diameter (mm)	Reel Width W1 (mm)	A0 (mm)	B0 (mm)	K0 (mm)	P1 (mm)	W (mm)	Pin1 Quadrant
SN74AVCH8T245DGVR	TVSOP	DGV	24	2000	330.0	12.4	6.9	5.6	1.6	8.0	12.0	Q1
SN74AVCH8T245PWR	TSSOP	PW	24	2000	330.0	16.4	6.95	8.3	1.6	8.0	16.0	Q1
SN74AVCH8T245RHLR	QFN	RHL	24	1000	180.0	12.4	3.8	5.8	1.2	8.0	12.0	Q1



**TAPE AND REEL BOX DIMENSIONS**



\*All dimensions are nominal

Device	Package Type	Package Drawing	Pins	SPQ	Length (mm)	Width (mm)	Height (mm)
SN74AVCH8T245DGVR	TVSOP	DGV	24	2000	346.0	346.0	29.0
SN74AVCH8T245PWR	TSSOP	PW	24	2000	346.0	346.0	33.0
SN74AVCH8T245RHLR	QFN	RHL	24	1000	190.5	212.7	31.8

# MECHANICAL DATA

RHL (R-PVQFN-N24)

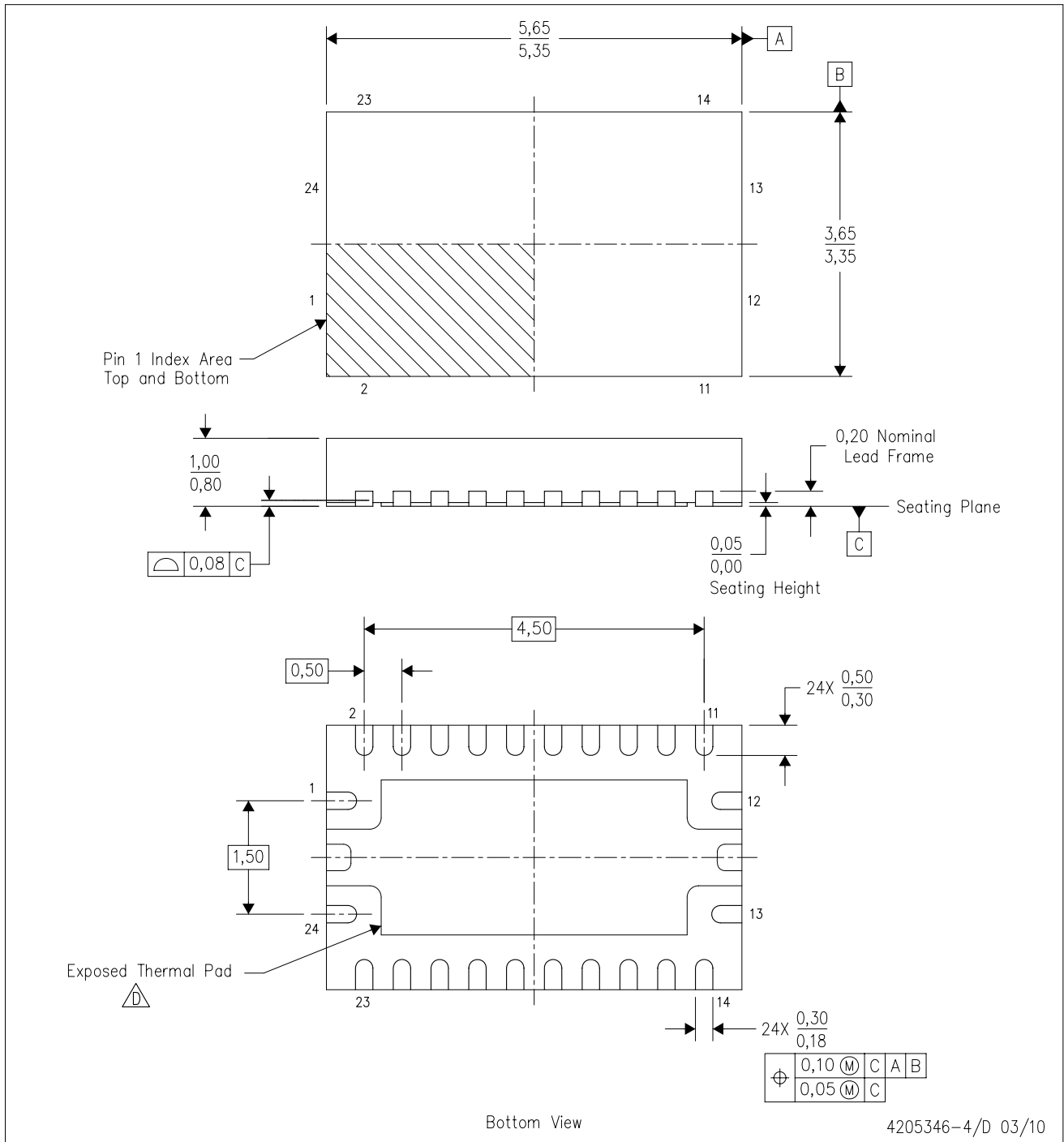
PLASTIC QUAD FLATPACK NO-LEAD



- NOTES:
- A. All linear dimensions are in millimeters. Dimensioning and tolerancing per ASME Y14.5M-1994.
  - B. This drawing is subject to change without notice.
  - C. QFN (Quad Flatpack No-Lead) package configuration.
  - D. The package thermal pad must be soldered to the board for thermal and mechanical performance. See the Product Data Sheet for details regarding the exposed thermal pad dimensions.
  - E. JEDEC MO-241 package registration pending.

## THERMAL PAD MECHANICAL DATA

RHL (R-PVQFN-N24)

PLASTIC QUAD FLATPACK NO-LEAD

### THERMAL INFORMATION

This package incorporates an exposed thermal pad that is designed to be attached directly to an external heatsink. The thermal pad must be soldered directly to the printed circuit board (PCB). After soldering, the PCB can be used as a heatsink. In addition, through the use of thermal vias, the thermal pad can be attached directly to the appropriate copper plane shown in the electrical schematic for the device, or alternatively, can be attached to a special heatsink structure designed into the PCB. This design optimizes the heat transfer from the integrated circuit (IC).

For information on the Quad Flatpack No-Lead (QFN) package and its advantages, refer to Application Report, QFN/SON PCB Attachment, Texas Instruments Literature No. SLUA271. This document is available at [www.ti.com](http://www.ti.com).

The exposed thermal pad dimensions for this package are shown in the following illustration.

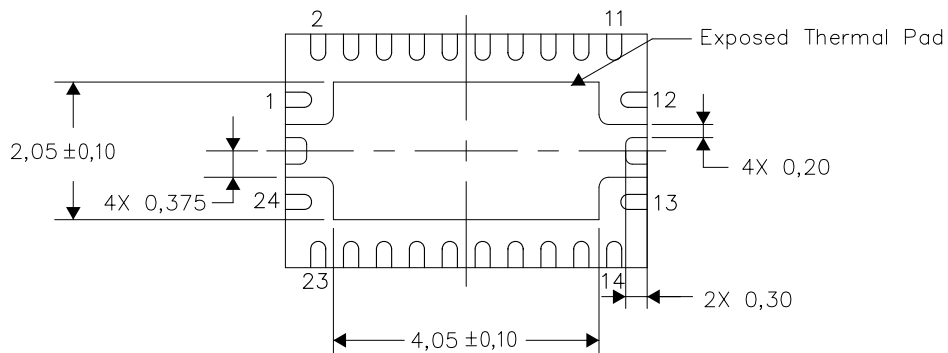

Bottom View

NOTE: All linear dimensions are in millimeters

Exposed Thermal Pad Dimensions

4206363-4/J 03/10

RHL (R-PVQFN-N24)

PLASTIC QUAD FLATPACK NO-LEAD

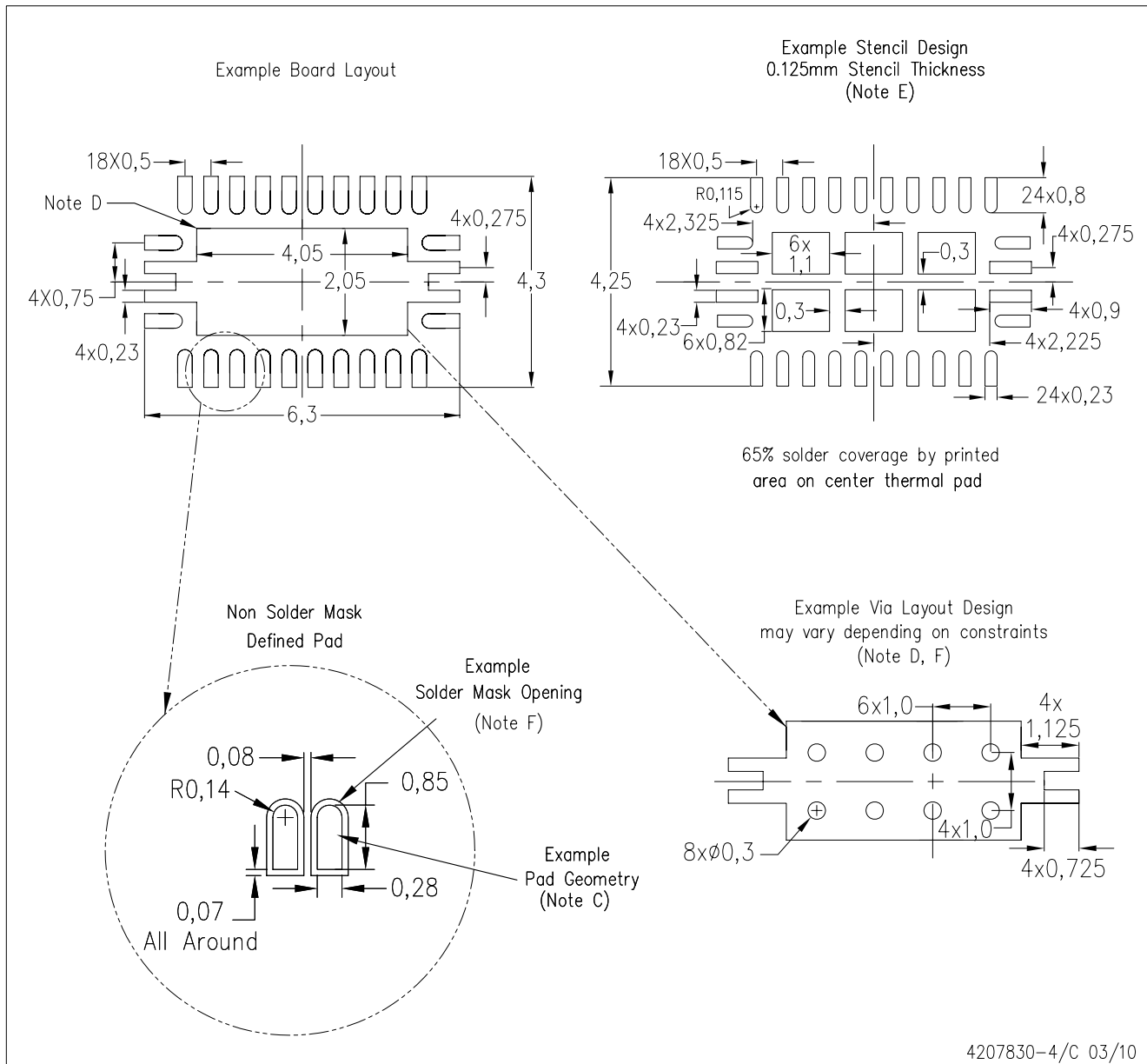

- NOTES:
- A. All linear dimensions are in millimeters.
  - B. This drawing is subject to change without notice.
  - C. Publication IPC-7351 is recommended for alternate designs.
  - D. This package is designed to be soldered to a thermal pad on the board. Refer to Application Note, Quad Flat-Pack Packages, Texas Instruments Literature No. SLUA271, and also the Product Data Sheets for specific thermal information, via requirements, and recommended board layout. These documents are available at [www.ti.com](http://www.ti.com) <<http://www.ti.com>>.
  - E. Laser cutting apertures with trapezoidal walls and also rounding corners will offer better paste release. Customers should contact their board assembly site for stencil design recommendations. Refer to IPC 7525 for stencil design considerations.
  - F. Customers should contact their board fabrication site for minimum solder mask web tolerances between signal pads.

PW (R-PDSO-G\*\*)

PLASTIC SMALL-OUTLINE PACKAGE

14 PINS SHOWN



4040064/F 01/97

- NOTES: A. All linear dimensions are in millimeters.  
 B. This drawing is subject to change without notice.  
 C. Body dimensions do not include mold flash or protrusion not to exceed 0,15.  
 D. Falls within JEDEC MO-153

## IMPORTANT NOTICE

Texas Instruments Incorporated and its subsidiaries (TI) reserve the right to make corrections, modifications, enhancements, improvements, and other changes to its products and services at any time and to discontinue any product or service without notice. Customers should obtain the latest relevant information before placing orders and should verify that such information is current and complete. All products are sold subject to TI's terms and conditions of sale supplied at the time of order acknowledgment.

TI warrants performance of its hardware products to the specifications applicable at the time of sale in accordance with TI's standard warranty. Testing and other quality control techniques are used to the extent TI deems necessary to support this warranty. Except where mandated by government requirements, testing of all parameters of each product is not necessarily performed.

TI assumes no liability for applications assistance or customer product design. Customers are responsible for their products and applications using TI components. To minimize the risks associated with customer products and applications, customers should provide adequate design and operating safeguards.

TI does not warrant or represent that any license, either express or implied, is granted under any TI patent right, copyright, mask work right, or other TI intellectual property right relating to any combination, machine, or process in which TI products or services are used. Information published by TI regarding third-party products or services does not constitute a license from TI to use such products or services or a warranty or endorsement thereof. Use of such information may require a license from a third party under the patents or other intellectual property of the third party, or a license from TI under the patents or other intellectual property of TI.

Reproduction of TI information in TI data books or data sheets is permissible only if reproduction is without alteration and is accompanied by all associated warranties, conditions, limitations, and notices. Reproduction of this information with alteration is an unfair and deceptive business practice. TI is not responsible or liable for such altered documentation. Information of third parties may be subject to additional restrictions.

Resale of TI products or services with statements different from or beyond the parameters stated by TI for that product or service voids all express and any implied warranties for the associated TI product or service and is an unfair and deceptive business practice. TI is not responsible or liable for any such statements.

TI products are not authorized for use in safety-critical applications (such as life support) where a failure of the TI product would reasonably be expected to cause severe personal injury or death, unless officers of the parties have executed an agreement specifically governing such use. Buyers represent that they have all necessary expertise in the safety and regulatory ramifications of their applications, and acknowledge and agree that they are solely responsible for all legal, regulatory and safety-related requirements concerning their products and any use of TI products in such safety-critical applications, notwithstanding any applications-related information or support that may be provided by TI. Further, Buyers must fully indemnify TI and its representatives against any damages arising out of the use of TI products in such safety-critical applications.

TI products are neither designed nor intended for use in military/aerospace applications or environments unless the TI products are specifically designated by TI as military-grade or "enhanced plastic." Only products designated by TI as military-grade meet military specifications. Buyers acknowledge and agree that any such use of TI products which TI has not designated as military-grade is solely at the Buyer's risk, and that they are solely responsible for compliance with all legal and regulatory requirements in connection with such use.

TI products are neither designed nor intended for use in automotive applications or environments unless the specific TI products are designated by TI as compliant with ISO/TS 16949 requirements. Buyers acknowledge and agree that, if they use any non-designated products in automotive applications, TI will not be responsible for any failure to meet such requirements.

Following are URLs where you can obtain information on other Texas Instruments products and application solutions:

<b>Products</b>		<b>Applications</b>	
Amplifiers	<a href="http://amplifier.ti.com">amplifier.ti.com</a>	Audio	<a href="http://www.ti.com/audio">www.ti.com/audio</a>
Data Converters	<a href="http://dataconverter.ti.com">dataconverter.ti.com</a>	Automotive	<a href="http://www.ti.com/automotive">www.ti.com/automotive</a>
DLP® Products	<a href="http://www.dlp.com">www.dlp.com</a>	Communications and Telecom	<a href="http://www.ti.com/communications">www.ti.com/communications</a>
DSP	<a href="http://dsp.ti.com">dsp.ti.com</a>	Computers and Peripherals	<a href="http://www.ti.com/computers">www.ti.com/computers</a>
Clocks and Timers	<a href="http://www.ti.com/clocks">www.ti.com/clocks</a>	Consumer Electronics	<a href="http://www.ti.com/consumer-apps">www.ti.com/consumer-apps</a>
Interface	<a href="http://interface.ti.com">interface.ti.com</a>	Energy	<a href="http://www.ti.com/energy">www.ti.com/energy</a>
Logic	<a href="http://logic.ti.com">logic.ti.com</a>	Industrial	<a href="http://www.ti.com/industrial">www.ti.com/industrial</a>
Power Mgmt	<a href="http://power.ti.com">power.ti.com</a>	Medical	<a href="http://www.ti.com/medical">www.ti.com/medical</a>
Microcontrollers	<a href="http://microcontroller.ti.com">microcontroller.ti.com</a>	Security	<a href="http://www.ti.com/security">www.ti.com/security</a>
RFID	<a href="http://www.ti-rfid.com">www.ti-rfid.com</a>	Space, Avionics & Defense	<a href="http://www.ti.com/space-avionics-defense">www.ti.com/space-avionics-defense</a>
RF/IF and ZigBee® Solutions	<a href="http://www.ti.com/lprf">www.ti.com/lprf</a>	Video and Imaging	<a href="http://www.ti.com/video">www.ti.com/video</a>
		Wireless	<a href="http://www.ti.com/wireless-apps">www.ti.com/wireless-apps</a>