

AUDIO CODEC AC'97 VOLTAGE-TRANSLATION TRANSCEIVER

FEATURES

- **Voltage-Level Transceiver for Interfacing 1.8 V Audio Codec (AC'97) Controllers With 3.3 V AC'97 Codec Links**
- **Configurable I/O Switching Levels With Dual-Supply Pins Operating Over Full 1.2-V to 3.6-V Power-Supply Range**
- **For Low-Power Operation, A and B Ports Are Placed in High-Impedance State When Either Supply Voltage Is Switched Off**
- **Latch-Up Performance Exceeds 100 mA Per JESD 78, Class II**
- **ESD Protection Exceeds JESD 22**
 - 7000-V Human-Body Model (A114-A)
 - 200-V Machine Model (A115-A)
 - 1500-V Charged-Device Model (C101)

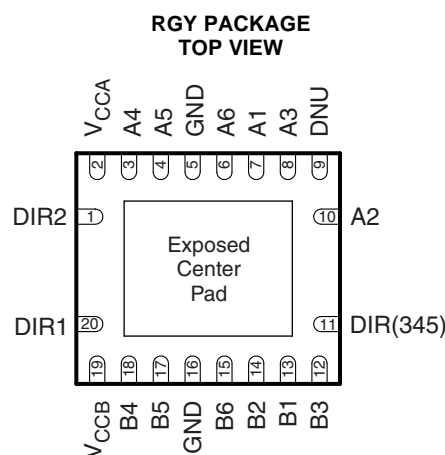
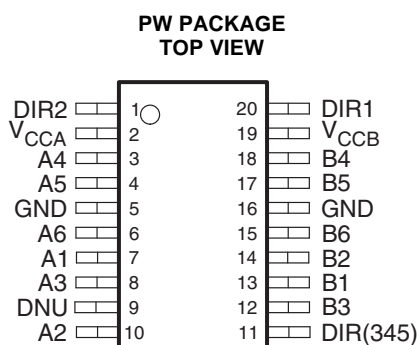

The exposed center pad, if used, must be connected as a secondary ground or left electrically open.

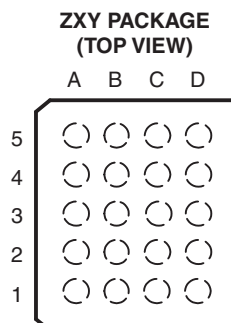

TERMINAL ASSIGNMENTS (20-Ball ZXY Package)

	A	B	C	D
5	V _{CCA}	DIR2	DIR1	V _{CCB}
4	A5	A4	B4	B5
3	A6	GND	GND	B6
2	A3	A1	B2	B1
1	DNU ⁽¹⁾	A2	DIR(345)	B3

(1) DNU – Do not use; should be left unconnected

DESCRIPTION/ORDERING INFORMATION

The SN74AVC6T622 is a voltage-level transceiver for interfacing 1.8 V audio codec (AC'97) controllers, the audio/analog modem functionality found in personal computers, with 3.3V AC'97 codec links. With the digital switching levels of today's AC'97 codecs lowering to 1.8-V logic levels, the SN74AVC6T622 device can be used to bridge the gap between legacy 3.3-V AC'97 codecs and AC'97 controllers that are now operating at 1.8 V. The 6-bit wide SN74AVC6T622 device complies with the AC'97 electrical interface (both levels and timing) specification.



Please be aware that an important notice concerning availability, standard warranty, and use in critical applications of Texas Instruments semiconductor products and disclaimers thereto appears at the end of this data sheet.

Two supply-voltage pins allow the A-port and B-port input switching thresholds to be configured separately. The A port is designed to track V_{CCA} , while the B port is designed to track V_{CCB} . V_{CCA} and V_{CCB} can accept any supply voltage from 1.2 V to 3.6 V.

If either V_{CC} is switched off ($V_{CCA} = 0$ V and/or $V_{CCB} = 0$ V), all outputs are placed in the high-impedance state to conserve power.

The SN74AVC6T622 is available in two 0.5-mm-pitch ball grid array (BGA) packages. The 20-ball package has dimensions of 3 mm × 2.5 mm, and the 24-ball package measures 3 mm × 3 mm. Memory cards are widely used in mobile phones, PDAs, digital cameras, personal media players, camcorders, set-top boxes, etc. Low static power consumption and small package size make the SN74AVC6T622 an ideal choice for these applications.

ORDERING INFORMATION

T_A	PACKAGE ⁽¹⁾⁽²⁾		ORDERABLE PART NUMBER	TOP-SIDE MARKING
-40°C to 85°C	QFN – RGY	Reel of 1000	SN74AVC6T622RGYR	WU622
	TSSOP – PW	Reel of 2000	SN74AVC6T622PWR	WU622
	UFBGA – ZXY (Pb-Free)	Reel of 2500	SN74AVC6T622ZX YR	WU622

- (1) Package drawings, thermal data, and symbolization are available at www.ti.com/packaging.
- (2) For the most current package and ordering information, see the Package Option Addendum at the end of this document, or see the TI website at www.ti.com.

REFERENCE DESIGN

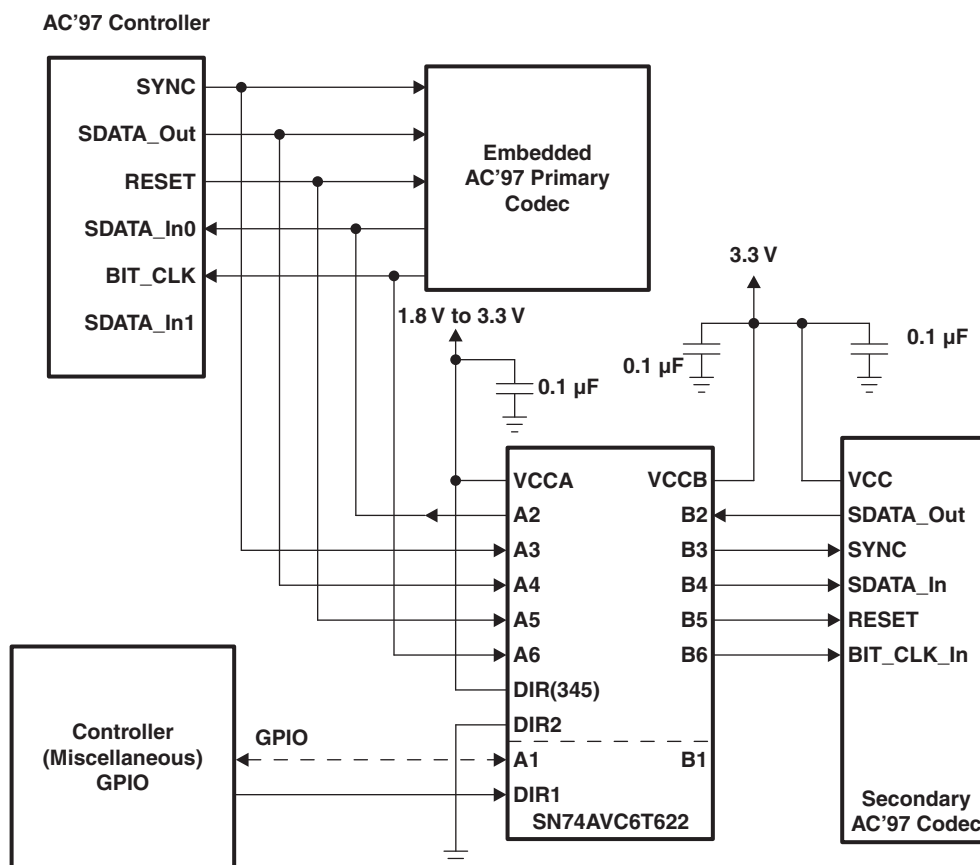

Figure 1. Interfacing 1.8 V AC'97 Controllers With 3.3 V AC'97 Controllers

TERMINAL FUNCTIONS

ZXY BALL NO.	RGY, PW PIN NO.	NAME	TYPE	DESCRIPTION
A1	9	DNU		Do not use; leave unconnected
A2	8	A3	I	AC'97 controller SYNC signal
A3	6	A6	I	AC'97 controller BIT_CLK signal
A4	4	A5	I	AC'97 controller RESET signal
A5	2	V _{CCA}	Pwr	A-port supply voltage. V _{CCA} powers all A-port I/Os and control pins.
B1	10	A2	O	AC'97 controller SDATA_In0 signal
B2	7	A1	I/O	GPIO to miscellaneous GPIO controller
B3, C3	5, 16	GND	–	Ground
B4	3	A4	I	AC'97 controller SDATA_Out signal
B5	1	DIR2	–	Should be tied to GND
C1	11	DIR(345)	–	Should be tied to V _{CCA}
C2	14	B2	I	Secondary AC'97 codec SDATA_Out signal
C4	18	B4	O	Secondary AC'97 codec SDATA_In signal
C5	20	DIR1	I	Direction control from miscellaneous GPIO controller
D1	12	B3	O	Secondary AC'97 codec SYNC signal
D2	13	B1	O	Optional GPIO signal if A1 is enabled
D3	15	B6	O	Secondary AC'97 codec BIT_CLK_In signal
D4	17	B5	O	Secondary AC'97 codec RESET signal
D5	19	V _{CCB}	Pwr	B-port supply voltage. V _{CCB} powers all B-port I/Os and control pins.

FUNCTION TABLES

CONTROL INPUT DIR2	OUTPUT CIRCUITS		OPERATION
	A2	B2	
High	Hi-Z	Enabled	A2 to B2
Low	Enabled	Hi-Z	B2 to A2

CONTROL INPUT DIR1	OUTPUT CIRCUITS		FUNCTION
	A1	B1	
High	Hi-Z	Enabled	A1 to B1
Low	Enabled	Hi-Z	B1 to A1

CONTROL INPUT DIR(345)	OUTPUT CIRCUITS		FUNCTION
	A3, A4, A5	B3, B4, B5	
High	Hi-Z	Enabled	A3 to B3
			A4 to B4
			A5 to B5
Low	Enabled	Hi-Z	B3 to A3
			B4 to A4
			B5 to A5

LOGIC DIAGRAM (POSITIVE LOGIC)

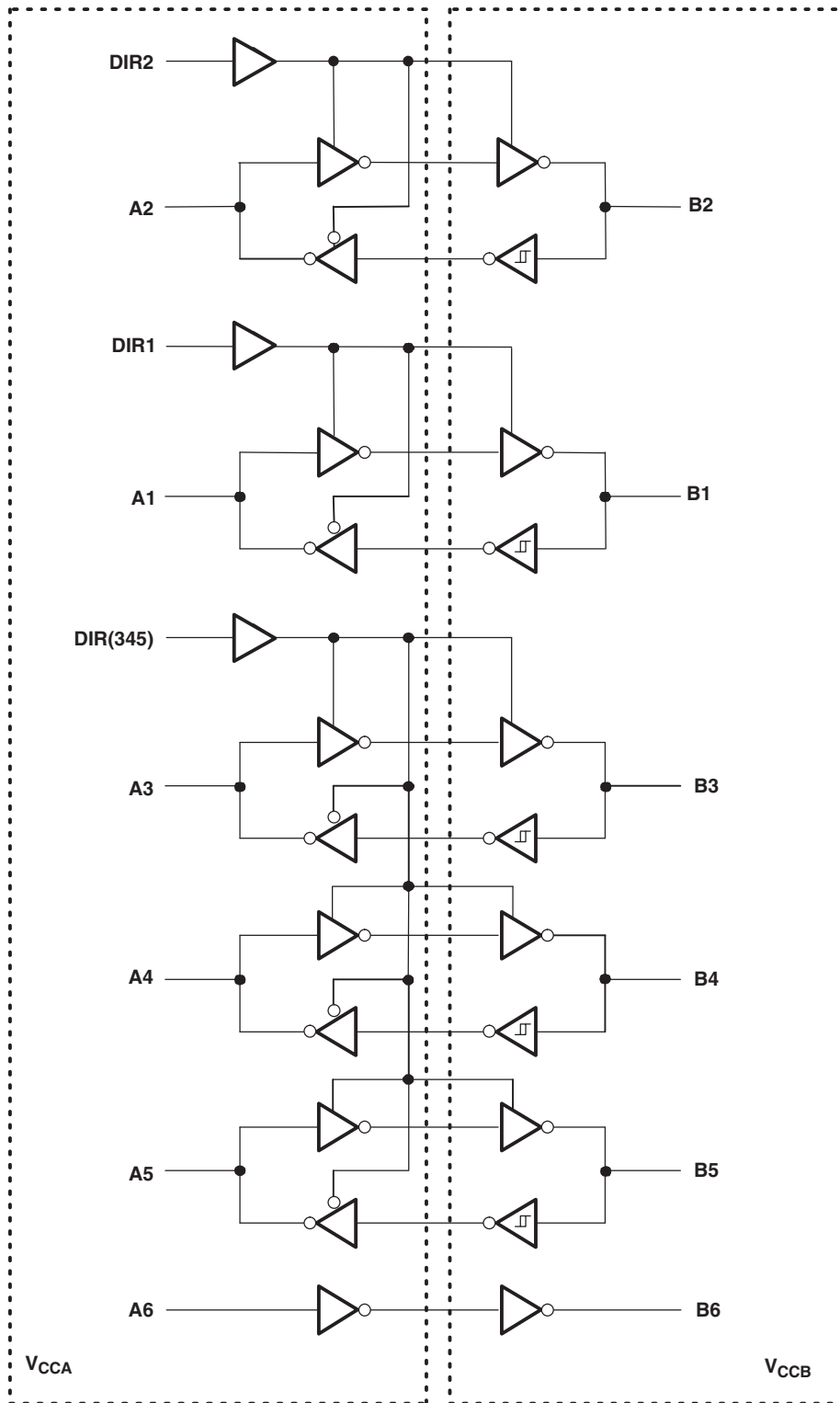

ABSOLUTE MAXIMUM RATINGS⁽¹⁾

over operating free-air temperature range (unless otherwise noted)

		MIN	MAX	UNIT	
V_{CCA} V_{CCB}	Supply voltage range	–0.5	4.6	V	
V_I	Input voltage range ⁽²⁾	I/O ports (A port)	–0.5	4.6	V
		I/O ports (B port)	–0.5	4.6	
		Control inputs	–0.5	4.6	
V_O	Voltage range applied to any output in the high-impedance or power-off state ⁽²⁾	A port	–0.5	4.6	V
		B port	–0.5	4.6	
V_O	Voltage range applied to any output in the high or low state ⁽²⁾⁽³⁾	A port	–0.5	$V_{CCA} + 0.5$	V
		B port	–0.5	$V_{CCB} + 0.5$	
I_{IK}	Input clamp current	$V_I < 0$	–50	mA	
I_{OK}	Output clamp current	$V_O < 0$	–50	mA	
I_O	Continuous output current		±50	mA	
	Continuous current through V_{CCA} , V_{CCB} , or GND		±100	mA	
θ_{JA}	Package thermal impedance	PW package ⁽⁴⁾	83	°C/W	
		RGY package ⁽⁵⁾	37		
		ZXY package ⁽⁴⁾	193		
T_{stg}	Storage temperature range	–65	150	°C	

- (1) Stresses beyond those listed under "absolute maximum ratings" may cause permanent damage to the device. These are stress ratings only, and functional operation of the device at these or any other conditions beyond those indicated under "recommended operating conditions" is not implied. Exposure to absolute-maximum-rated conditions for extended periods may affect device reliability.
- (2) The input voltage and output negative-voltage ratings may be exceeded if the input and output current ratings are observed.
- (3) The output positive-voltage rating may be exceeded up to 4.6 V maximum if the output current rating is observed.
- (4) The package thermal impedance is calculated in accordance with JESD 51-7.
- (5) The package thermal impedance is calculated in accordance with JESD 51-5.

RECOMMENDED OPERATING CONDITIONS⁽¹⁾⁽²⁾⁽³⁾

		V_{CCI}	V_{CCO}	MIN	MAX	UNIT
V_{CCA}	Supply voltage			1.2	3.6	V
V_{CCB}	Supply voltage			1.2	3.6	V
V_{IH}	High-level input voltage	All inputs ⁽⁴⁾	1.2 V to 1.95 V	$V_{CCI} \times 0.65$		V
			1.95 V to 2.7 V	1.7		
			2.7 V to 3.6 V	2		
V_{IL}	Low-level input voltage	All inputs ⁽⁴⁾	1.2 V to 1.95 V	$V_{CCI} \times 0.35$		V
			1.95 V to 2.7 V	0.7		
			2.7 V to 3.6 V	0.8		
V_I	Input voltage	Control inputs		0	3.6	V
V_{IO}	Input/output voltage	Active state		0	V_{CCO}	V
		3-state		0	3.6	
I_{OH}	High-level output current (A port)		1.2 V	-1		mA
			1.4 V to 1.6 V	-1		
			1.65 V to 1.95 V	-2		
			2.3 V to 2.7 V	-4		
			3 V to 3.6 V	-8		
I_{OL}	Low-level output current (A port)		1.2 V	1		mA
			1.4 V to 1.6 V	1		
			1.65 V to 1.95 V	2		
			2.3 V to 2.7 V	4		
			3 V to 3.6 V	8		
I_{OH}	High-level output current (B port)		1.2 V	-1		mA
			1.4 V to 1.6 V	-2		
			1.65 V to 1.95 V	-4		
			2.3 V to 2.7 V	-8		
			3 V to 3.6 V	-16		
I_{OL}	Low-level output current (B port)		1.2 V	1		mA
			1.4 V to 1.6 V	2		
			1.65 V to 1.95 V	4		
			2.3 V to 2.7 V	8		
			3 V to 3.6 V	16		
$\Delta t/\Delta v$	Input transition rise or fall rate				5	ns/V
T_A	Operating free-air temperature			-40	85	°C

(1) V_{CCI} is the V_{CC} associated with the input port.

(2) V_{CCO} is the V_{CC} associated with the output port.

(3) All unused data inputs of the device must be held at V_{CCI} or GND to ensure proper device operation. Refer to the TI application report, *Implications of Slow or Floating CMOS Inputs*, literature number SCBA004.

(4) DIR2, DIR1, and DIR(345) are referenced to V_{CCA} .

ELECTRICAL CHARACTERISTICS⁽¹⁾⁽²⁾

over recommended operating free-air temperature range (unless otherwise noted)

PARAMETER		TEST CONDITIONS		V _{CCA}	V _{CCB}	T _A = 25°C			UNIT
						MIN	TYP ⁽³⁾	MAX	
V _{OH}	A port	I _{OH} = -100 μA	V _I = V _{IH}	1.2 V to 3.6 V	1.2 V to 3.6 V	V _{CCO} - 0.2			V
		I _{OH} = -1 mA		1.2 V	1.2 V	1.1			
		I _{OH} = -2 mA		1.4 V	1.4 V	1.05			
		I _{OH} = -4 mA		1.65 V	1.65 V	1.2			
		I _{OH} = -8 mA		2.3 V	2.3 V	1.75			
		I _{OH} = -8 mA		3 V	3 V	2.3			
V _{OL}	A port	I _{OL} = 100 μA	V _I = V _{IL}	1.2 V to 3.6 V	1.2 V to 3.6 V	0.2			V
		I _{OL} = 1 mA		1.2 V	1.2 V	0.07			
		I _{OL} = 2 mA		1.4 V	1.4 V	0.35			
		I _{OL} = 4 mA		1.65 V	1.65 V	0.45			
		I _{OL} = 8 mA		2.3 V	2.3 V	0.55			
		I _{OL} = 8 mA		3 V	3 V	0.7			
V _{OH}	B port	I _{OH} = -100 μA	V _I = V _{IH}	1.2 V to 3.6 V	1.2 V to 3.6 V	V _{CCO} - 0.2			V
		I _{OH} = -1 mA		1.2 V	1.2 V	1.1			
		I _{OH} = -2 mA		1.4 V	1.4 V	1.05			
		I _{OH} = -4 mA		1.65 V	1.65 V	1.2			
		I _{OH} = -8 mA		2.3 V	2.3 V	1.75			
		I _{OH} = -16 mA		3 V	3 V	2.3			
V _{OL}	B port	I _{OL} = 100 μA	V _I = V _{IL}	1.2 V to 3.6 V	1.2 V to 3.6 V	0.2			V
		I _{OL} = 1 mA		1.2 V	1.2 V	0.07			
		I _{OL} = 2 mA		1.4 V	1.4 V	0.35			
		I _{OL} = 4 mA		1.65 V	1.65 V	0.45			
		I _{OL} = 8 mA		2.3 V	2.3 V	0.55			
		I _{OL} = 16 mA		3 V	3 V	0.7			
I _I	Control inputs	V _I = V _{CCA} or GND		1.2 V to 3.6 V	1.2 V to 3.6 V	±1			μA
I _{off}	A or B port	V _I or V _O = 0 to 3.6 V		0 V	0 V to 3.6 V	±5			μA
				0 V to 3.6 V	0 V	±5			
I _{OZ} ⁽⁴⁾	A or B port	V _O = V _{CCO} or GND, V _I = V _{CCI} or GND	See function table for input states when outputs are Hi Z	3.6 V	3.6 V	±5			μA
I _{CCA}	V _I = V _{CCI} or GND, I _O = 0		1.2 V to 3.6 V		1.2 V to 3.6 V	10			μA
			3.6 V		0 V	10			
			0 V		3.6 V	-1			
I _{CCB}	V _I = V _{CCI} or GND, I _O = 0		1.2 V to 3.6 V		1.2 V to 3.6 V	10			μA
			3.6 V		0 V	-1			
			0 V		3.6 V	10			
I _{CCA} + I _{CCB}	V _I = V _{CCI} or GND, I _O = 0		1.2 V to 3.6 V		1.2 V to 3.6 V	15			μA
C _i	Control inputs	V _I = V _{CCA} or GND		1.8 V	3 V	1.5		2	pF
	Clock input					2			
C _{io}	A port	V _O = V _{CCA} or GND		1.8 V	3 V	2.5		3	pF
	B port	V _O = V _{CCB} or GND				2.5			

(1) V_{CCO} is the V_{CC} associated with the output port.(2) V_{CCI} is the V_{CC} associated with the input port.(3) All typical values are at T_A = 25°C.(4) For I/O ports, the parameter I_{OZ} includes the input leakage current.

OUTPUT SLEW RATES⁽¹⁾

over recommended operating free-air temperature range (unless otherwise noted)

PARAMETER	FROM	TO	V _{CCA} = 1.8 V ± 0.15 V, V _{CCB} = 3 V ± 0.3 V		UNIT
			MIN	MAX	
t _r	10%	90%	3 ⁽²⁾		ns
t _f	90%	10%	3 ⁽²⁾		ns

- (1) Values are characterized, but not production tested.
 (2) Using C_L = 15 pF on the B side and C_L = 7 pF on the A side

TYPICAL SWITCHING CHARACTERISTICS

T_A = 25°C, V_{CCA} = 1.2 V (see [Figure 2](#))

PARAMETER	FROM (INPUT)	TO (OUTPUT)	V _{CCB} = 1.2 V	V _{CCB} = 1.5 V	V _{CCB} = 1.8 V	V _{CCB} = 2.5 V	V _{CCB} = 3 V	V _{CCB} = 3.3 V	UNIT
			TYP	TYP	TYP	TYP	TYP	TYP	
t _{pd}	A	B	3.8	3	2.6	2.5	2.5	2.6	ns
	B	A	4.6	4.2	4	3.9	3.9	3.8	
	A6	B6	3.8	3	2.6	2.5	2.5	2.6	
	A2	B2	3.8	3	2.6	2.5	2.5	2.6	
	B2	A2	4.6	4.2	4	3.9	3.9	3.8	
t _{en} ⁽¹⁾	DIR	B	4.8	4	3.7	3.4	3.4	3.4	ns
		A	4.5	4.4	5	5.4	5.4	5.4	
t _{dis} ⁽¹⁾	DIR	B	6.3	5.2	5.6	4.8	4.8	6.1	ns
		A	4.8	4.6	5.3	5.4	5.4	5.3	

- (1) DIR refers to DIR2, DIR1, and DIR(345).

SWITCHING CHARACTERISTICS

over recommended operating free-air temperature range, V_{CCA} = 1.5 V ± 0.1 V (see [Figure 2](#))

PARAMETER	FROM (INPUT)	TO (OUTPUT)	V _{CCB} = 1.2 V	V _{CCB} = 1.5 V ± 0.1 V		V _{CCB} = 1.8 V ± 0.15 V		V _{CCB} = 2.5 V ± 0.2 V		V _{CCB} = 3 V ± 0.3 V		V _{CCB} = 3.3 V ± 0.3 V		UNIT
			TYP	MIN	MAX	MIN	MAX	MIN	MAX	MIN	MAX	MIN	MAX	
t _{pd}	A	B	3.4	1.1	5.6	1	4.8	1	3.9	0.9	3.9	0.9	3.8	ns
	B	A	3.8	1.4	6	1.3	5.6	1.3	5.2	0.5	5.2	0.3	5.2	
	A6	B6	3.4	1.1	5.6	1	4.8	1	3.9	0.9	3.9	0.9	3.8	
	A2	B2	3.4	1.1	5.6	1	4.8	1	3.9	0.9	3.9	0.9	3.8	
	B2	A2	3.8	1.4	6	1.3	5.6	1.3	5.2	0.5	5.2	0.3	5.2	
t _{en} ⁽¹⁾	DIR	B	4	1.3	7.7	1.1	6.9	0.8	6.1	0.8	6	0.8	5.9	ns
		A	3.5	1.4	7	1.5	7.4	1.7	8.2	1.7	8.2	1.7	7.7	
t _{dis} ⁽¹⁾	DIR	B	5.7	1.9	8.9	2.1	10.4	1.8	8.7	1.7	8.5	2.4	11.4	ns
		A	3.4	1.2	7	1.2	6.8	1.2	6.9	1.2	6.5	1.2	6.6	

- (1) DIR refers to DIR2, DIR1, and DIR(345).

SWITCHING CHARACTERISTICS

over recommended operating free-air temperature range, $V_{CCA} = 1.8 \text{ V} \pm 0.15 \text{ V}$ (see [Figure 2](#))

PARAMETER	FROM (INPUT)	TO (OUTPUT)	$V_{CCB} = 1.2 \text{ V}$	$V_{CCB} = 1.5 \text{ V} \pm 0.1 \text{ V}$		$V_{CCB} = 1.8 \text{ V} \pm 0.15 \text{ V}$		$V_{CCB} = 2.5 \text{ V} \pm 0.2 \text{ V}$		$V_{CCB} = 3 \text{ V} \pm 0.3 \text{ V}$		$V_{CCB} = 3.3 \text{ V} \pm 0.3 \text{ V}$		UNIT
			TYP	MIN	MAX	MIN	MAX	MIN	MAX	MIN	MAX	MIN	MAX	
t_{pd}	A	B	3.2	1	5.2	0.8	4.4	0.7	3.5	0.6	3.4	0.7	3.1	ns
	B	A	3.4	1.1	5.2	1	4.8	0.9	4.3	0.3	4.3	0.2	4.3	
	A6	B6	3.2	1	5.2	0.8	4.4	0.7	3.5	0.6	3.4	0.7	3.1	
	A2	B2	3.2	1	5.2	0.8	4.4	0.7	3.5	0.6	3.4	0.7	3.1	
	B2	A2	3.4	1.1	5.2	1	4.8	0.9	4.3	0.3	4.3	0.2	4.3	
$t_{en}^{(1)}$	DIR	B	3.5	1.2	6.8	0.9	6	0.7	5.1	0.7	5	0.7	4.8	ns
		A	2.9	1.1	4.7	1.1	5.2	1.4	5.1	1.4	5.1	1.4	5.3	
$t_{dis}^{(1)}$	DIR	B	5.3	1.6	8.4	2	9.5	1.6	8.2	1.4	8.1	2.2	8.2	ns
		A	3.6	1.3	7.7	1.2	7.9	1.3	7.5	1.3	7.5	1.3	7.6	

(1) DIR refers to DIR2, DIR1, and DIR(345).

SWITCHING CHARACTERISTICS

over recommended operating free-air temperature range, $V_{CCA} = 2.5 \text{ V} \pm 0.2 \text{ V}$ (see [Figure 2](#))

PARAMETER	FROM (INPUT)	TO (OUTPUT)	$V_{CCB} = 1.2 \text{ V}$	$V_{CCB} = 1.5 \text{ V} \pm 0.1 \text{ V}$		$V_{CCB} = 1.8 \text{ V} \pm 0.15 \text{ V}$		$V_{CCB} = 2.5 \text{ V} \pm 0.2 \text{ V}$		$V_{CCB} = 3 \text{ V} \pm 0.3 \text{ V}$		$V_{CCB} = 3.3 \text{ V} \pm 0.3 \text{ V}$		UNIT
			TYP	MIN	MAX	MIN	MAX	MIN	MAX	MIN	MAX	MIN	MAX	
t_{pd}	A	B	3	0.8	4.7	0.7	3.8	0.6	2.9	0.4	2.7	0.5	2.5	ns
	B	A	3	0.9	4.4	0.7	3.9	0.6	3.3	0.3	3.2	0.3	3.2	
	A6	B6	3	0.8	4.7	0.7	3.8	0.6	2.9	0.4	2.7	0.5	2.5	
	A2	B2	3	0.8	4.7	0.7	3.8	0.6	2.9	0.4	2.7	0.5	2.5	
	B2	A2	3	0.9	4.4	0.7	3.9	0.6	3.3	0.3	3.2	0.3	3.2	
$t_{en}^{(1)}$	DIR	B	3.1	1	5.7	0.8	4.8	0.5	3.9	0.5	3.7	0.5	3.6	ns
		A	2.2	0.7	3.5	0.6	4.3	1.2	4.4	0.7	4.6	0.4	4.7	
t_{dis}	DIR	B	4.6	1.4	7.6	1.8	8.4	1.3	7.2	1.3	7.1	2	7.5	ns
		A	2.6	0.9	5.6	0.9	5.4	1	5.5	0.9	5.5	0.9	5.8	

(1) DIR refers to DIR2, DIR1, and DIR(345).

SWITCHING CHARACTERISTICS

 over recommended operating free-air temperature range, $V_{CCA} = 3.3 \text{ V} \pm 0.3 \text{ V}$ (see Figure 2)

PARAMETER	FROM (INPUT)	TO (OUTPUT)	$V_{CCB} = 1.2 \text{ V}$	$V_{CCB} = 1.5 \text{ V} \pm 0.1 \text{ V}$		$V_{CCB} = 1.8 \text{ V} \pm 0.15 \text{ V}$		$V_{CCB} = 2.5 \text{ V} \pm 0.2 \text{ V}$		$V_{CCB} = 3 \text{ V} \pm 0.3 \text{ V}$		$V_{CCB} = 3.3 \text{ V} \pm 0.3 \text{ V}$		UNIT
			TYP	MIN	MAX	MIN	MAX	MIN	MAX	MIN	MAX	MIN	MAX	
t_{pd}	A	B	2.8	0.8	4.5	0.6	3.6	0.4	2.7	0.4	2.7	0.3	2.3	ns
	B	A	2.9	0.8	4.3	0.6	3.7	0.5	3	0.5	3	0.1	2.7	
	A6	B6	2.8	0.8	4.5	0.6	3.6	0.4	2.7	0.4	2.7	0.3	2.3	
	A2	B2	2.8	0.8	4.5	0.6	3.6	0.4	2.7	0.4	2.7	0.3	2.3	
	B2	A2	2.9	0.8	4.3	0.6	3.7	0.5	3	0.5	3	0.1	2.7	
$t_{en}^{(1)}$	DIR	B	3	1	5.1	0.6	4.3	0.5	3.4	0.5	3.4	0.4	3	ns
		A	2	0.6	3.1	0.6	5.4	0.7	5.4	0.7	5.4	0.5	5.4	
$t_{dis}^{(1)}$	DIR	B	4.4	1.4	7.4	1.8	8.3	1.2	7	1.2	7	2	7.3	ns
		A	3.7	1.5	8.1	1.5	7.9	1.5	7.9	1.5	7.9	1.5	8	

(1) DIR refers to DIR2, DIR1, and DIR(345).

TYPICAL FREQUENCY AND OUTPUT SKEW

 $T_A = 25^\circ\text{C}$, $V_{CCA} = 1.2 \text{ V}$ (see Figure 2)

PARAMETER	FROM (INPUT)	TO (OUTPUT)	$V_{CCB} = 1.2 \text{ V}$	$V_{CCB} = 1.5 \text{ V}$	$V_{CCB} = 1.8 \text{ V}$	$V_{CCB} = 2.5 \text{ V}$	$V_{CCB} = 3 \text{ V}$	$V_{CCB} = 3.3 \text{ V}$	UNIT	
			TYP	TYP	TYP	TYP	TYP	TYP		
t_{max}	Clock	A6	B6	95	95	95	95	95	MHz	
	Data	A	B	95	95	95	95	95		
		B	A	95	95	95	95	95		
$t_{sk(o)}$	Channel-to-channel	A	B	0.5	0.4	0.4	0.3	0.5	0.5	ns

MAXIMUM FREQUENCY AND OUTPUT SKEW

 over recommended operating free-air temperature range, $V_{CCA} = 1.5 \text{ V} \pm 0.1 \text{ V}$ (see Figure 2)

PARAMETER	FROM (INPUT)	TO (OUTPUT)	$V_{CCB} = 1.2 \text{ V}$	$V_{CCB} = 1.5 \text{ V} \pm 0.1 \text{ V}$		$V_{CCB} = 1.8 \text{ V} \pm 0.15 \text{ V}$		$V_{CCB} = 2.5 \text{ V} \pm 0.2 \text{ V}$		$V_{CCB} = 3 \text{ V} \pm 0.3 \text{ V}$		$V_{CCB} = 3.3 \text{ V} \pm 0.3 \text{ V}$		UNIT
			TYP	MIN	MAX	MIN	MAX	MIN	MAX	MIN	MAX	MIN	MAX	
f_{max}	Clock	A6	B6	95	95	95	95	95	95	95	95	95	MHz	
	Data	A	B	95	95	95	95	95	95	95	95	95		
		B	A	95	95	95	95	95	95	95	95	95		
$t_{sk(o)}$	Channel-to-channel	DIR	B	0.3	0.3	0.3	0.3	0.3	0.5	0.5	0.4	0.4	ns	

MAXIMUM FREQUENCY AND OUTPUT SKEW

 over recommended operating free-air temperature range, $V_{CCA} = 1.8 \text{ V} \pm 0.15 \text{ V}$ (see Figure 2)

PARAMETER	FROM (INPUT)	TO (OUTPUT)	$V_{CCB} = 1.2 \text{ V}$	$V_{CCB} = 1.5 \text{ V} \pm 0.1 \text{ V}$		$V_{CCB} = 1.8 \text{ V} \pm 0.15 \text{ V}$		$V_{CCB} = 2.5 \text{ V} \pm 0.2 \text{ V}$		$V_{CCB} = 3 \text{ V} \pm 0.3 \text{ V}$		$V_{CCB} = 3.3 \text{ V} \pm 0.3 \text{ V}$		UNIT
			TYP	MIN	MAX	MIN	MAX	MIN	MAX	MIN	MAX	MIN	MAX	
f_{max}	Clock	A6	B6	95	95	95	95	95	95	95	95	95	MHz	
	Data	A	B	95	95	95	95	95	95	95	95	95		
		B	A	95	95	95	95	95	95	95	95	95		
$t_{sk(o)}$	Channel-to-channel	DIR	B	0.3	0.3	0.3	0.3	0.3	0.5	0.5	0.3	0.3	ns	

MAXIMUM FREQUENCY AND OUTPUT SKEW

over recommended operating free-air temperature range, $V_{CCA} = 2.5 \text{ V} \pm 0.2 \text{ V}$ (see [Figure 2](#))

PARAMETER	FROM (INPUT)	TO (OUTPUT)	$V_{CCB} = 1.2 \text{ V}$	$V_{CCB} = 1.5 \text{ V} \pm 0.1 \text{ V}$		$V_{CCB} = 1.8 \text{ V} \pm 0.15 \text{ V}$		$V_{CCB} = 2.5 \text{ V} \pm 0.2 \text{ V}$		$V_{CCB} = 3 \text{ V} \pm 0.3 \text{ V}$		$V_{CCB} = 3.3 \text{ V} \pm 0.3 \text{ V}$		UNIT
			TYP	MIN	MAX	MIN	MAX	MIN	MAX	MIN	MAX	MIN	MAX	
f_{\max}	Clock	A6	B6	95	95	95	95	95	95	95	95	95	MHz	
	Data	A	B	95	95	95	95	95	95	95	95	95		
		B	A	95	95	95	95	95	95	95	95	95		
$t_{sk(o)}$	Channel-to-channel	DIR	B	0.3	0.3	0.3	0.2	0.6	0.3	ns				

MAXIMUM FREQUENCY AND OUTPUT SKEW

over recommended operating free-air temperature range, $V_{CCA} = 3.3 \text{ V} \pm 0.3 \text{ V}$ (see [Figure 2](#))

PARAMETER	FROM (INPUT)	TO (OUTPUT)	$V_{CCB} = 1.2 \text{ V}$	$V_{CCB} = 1.5 \text{ V} \pm 0.1 \text{ V}$		$V_{CCB} = 1.8 \text{ V} \pm 0.15 \text{ V}$		$V_{CCB} = 2.5 \text{ V} \pm 0.2 \text{ V}$		$V_{CCB} = 3 \text{ V} \pm 0.3 \text{ V}$		$V_{CCB} = 3.3 \text{ V} \pm 0.3 \text{ V}$		UNIT
			TYP	MIN	MAX	MIN	MAX	MIN	MAX	MIN	MAX	MIN	MAX	
f_{\max}	Clock	A6	B6	95	95	95	95	95	95	95	95	MHz		
	Data	A	B	95	95	95	95	95	95	95	95			
		B	A	95	95	95	95	95	95	95	95			
$t_{sk(o)}$	Channel-to-channel	DIR	B	0.3	0.3	0.4	0.3	0.6	0.4	ns				

OPERATING CHARACTERISTICS
 $T_A = 25^\circ\text{C}$

PARAMETER		TEST CONDITIONS	$V_{CCA} =$ $V_{CCB} = 1.2\text{ V}$	$V_{CCA} =$ $V_{CCB} = 1.5\text{ V}$	$V_{CCA} =$ $V_{CCB} = 1.8\text{ V}$	$V_{CCA} =$ $V_{CCB} = 2.5\text{ V}$	$V_{CCA} =$ $V_{CCB} = 3\text{ V}$	$V_{CCA} =$ $V_{CCB} = 3.3\text{ V}$	UNIT
			TYP	TYP	TYP	TYP	TYP	TYP	
$C_{pdA}^{(1)}$	A-port input, B-port output	$C_L = 0,$ $f = 10\text{ MHz},$ $t_r = t_f = 1\text{ ns}$	1.9	2	2.1	2.4	2.7	2.9	pF
	B-port input, A-port output		4.4	4.5	4.6	4.7	4.8	4.9	
$C_{pdB}^{(1)}$	A-port input, B-port output	$C_L = 0,$ $f = 10\text{ MHz},$ $t_r = t_f = 1\text{ ns}$	5.3	5.4	5.4	5.7	5.8	5.9	pF
	B-port input, A-port output		0.3	0.3	0.4	0.5	0.6	0.6	

(1) Power dissipation capacitance per transceiver

PARAMETER MEASUREMENT INFORMATION

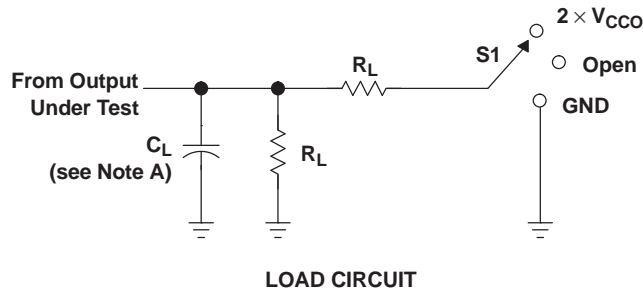

TEST	S1
t_{pd}	Open
t_{PLZ}/t_{PZL}	$2 \times V_{CCO}$
t_{PHZ}/t_{PZH}	GND

V_{CCO}	C_L	R_L	V_{TP}
$1.5\text{ V} \pm 0.1\text{ V}$	15 pF	2 k Ω	0.1 V
$1.8\text{ V} \pm 0.15\text{ V}$	15 pF	2 k Ω	0.15 V
$2.5\text{ V} \pm 0.2\text{ V}$	15 pF	2 k Ω	0.15 V
$3.3\text{ V} \pm 0.3\text{ V}$	15 pF	2 k Ω	0.3 V

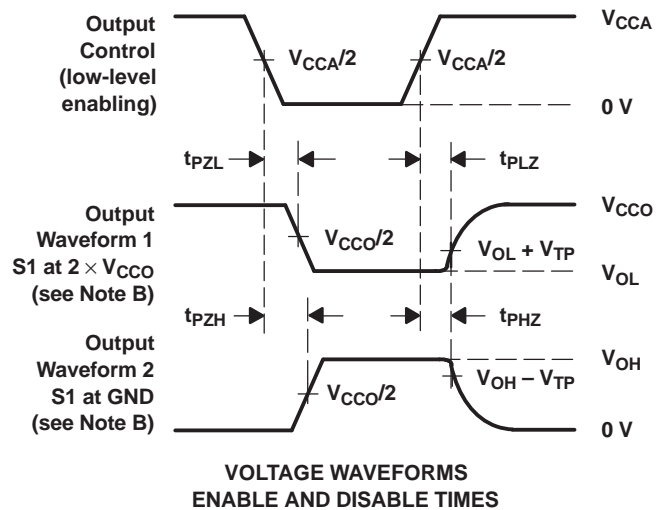
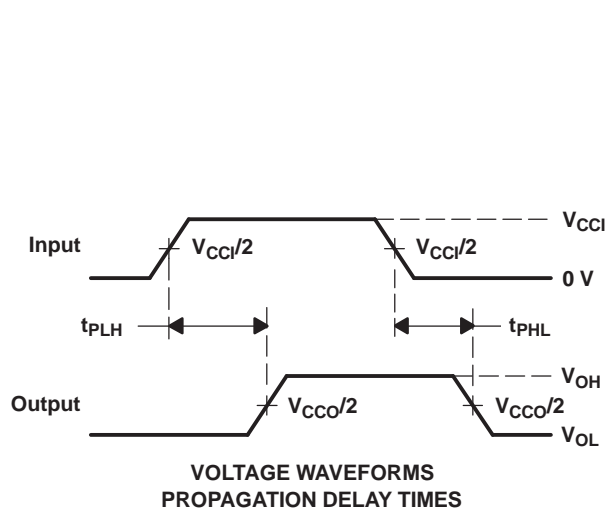

- NOTES:
- A. C_L includes probe and jig capacitance.
 - B. Waveform 1 is for an output with internal conditions such that the output is low, except when disabled by the output control. Waveform 2 is for an output with internal conditions such that the output is high, except when disabled by the output control.
 - C. All input pulses are supplied by generators having the following characteristics: $PRR \leq 10\text{ MHz}$, $Z_O = 50\ \Omega$, $dv/dt \geq 1\text{ V/ns}$.
 - D. The outputs are measured one at a time, with one transition per measurement.
 - E. t_{PLZ} and t_{PHZ} are the same as t_{dis} .
 - F. t_{PZL} and t_{PZH} are the same as t_{en} .
 - G. t_{PLH} and t_{PHL} are the same as t_{pd} .
 - H. V_{CCI} is the V_{CC} associated with the input port.
 - I. V_{CCO} is the V_{CC} associated with the output port.

Figure 2. Load Circuit and Voltage Waveforms

PACKAGING INFORMATION

Orderable Device	Status ⁽¹⁾	Package Type	Package Drawing	Pins	Package Qty	Eco Plan ⁽²⁾	Lead/Ball Finish	MSL Peak Temp ⁽³⁾
SN74AVC6T622PWR	ACTIVE	TSSOP	PW	20	2000	Green (RoHS & no Sb/Br)	CU NIPDAU	Level-1-260C-UNLIM
SN74AVC6T622PWRG4	ACTIVE	TSSOP	PW	20	2000	Green (RoHS & no Sb/Br)	CU NIPDAU	Level-1-260C-UNLIM
SN74AVC6T622RGYR	ACTIVE	QFN	RGY	20	1000	Green (RoHS & no Sb/Br)	CU NIPDAU	Level-2-260C-1 YEAR
SN74AVC6T622RGYR4	ACTIVE	QFN	RGY	20	1000	Green (RoHS & no Sb/Br)	CU NIPDAU	Level-2-260C-1 YEAR
SN74AVC6T622ZXZR	ACTIVE	BGA MI CROSTA R JUNI OR	ZXY	20	2500	Green (RoHS & no Sb/Br)	SNAGCU	Level-1-260C-UNLIM

⁽¹⁾ The marketing status values are defined as follows:

ACTIVE: Product device recommended for new designs.

LIFEBUY: TI has announced that the device will be discontinued, and a lifetime-buy period is in effect.

NRND: Not recommended for new designs. Device is in production to support existing customers, but TI does not recommend using this part in a new design.

PREVIEW: Device has been announced but is not in production. Samples may or may not be available.

OBSOLETE: TI has discontinued the production of the device.

⁽²⁾ Eco Plan - The planned eco-friendly classification: Pb-Free (RoHS), Pb-Free (RoHS Exempt), or Green (RoHS & no Sb/Br) - please check <http://www.ti.com/productcontent> for the latest availability information and additional product content details.

TBD: The Pb-Free/Green conversion plan has not been defined.

Pb-Free (RoHS): TI's terms "Lead-Free" or "Pb-Free" mean semiconductor products that are compatible with the current RoHS requirements for all 6 substances, including the requirement that lead not exceed 0.1% by weight in homogeneous materials. Where designed to be soldered at high temperatures, TI Pb-Free products are suitable for use in specified lead-free processes.

Pb-Free (RoHS Exempt): This component has a RoHS exemption for either 1) lead-based flip-chip solder bumps used between the die and package, or 2) lead-based die adhesive used between the die and leadframe. The component is otherwise considered Pb-Free (RoHS compatible) as defined above.

Green (RoHS & no Sb/Br): TI defines "Green" to mean Pb-Free (RoHS compatible), and free of Bromine (Br) and Antimony (Sb) based flame retardants (Br or Sb do not exceed 0.1% by weight in homogeneous material)

⁽³⁾ MSL, Peak Temp. -- The Moisture Sensitivity Level rating according to the JEDEC industry standard classifications, and peak solder temperature.

Important Information and Disclaimer:The information provided on this page represents TI's knowledge and belief as of the date that it is provided. TI bases its knowledge and belief on information provided by third parties, and makes no representation or warranty as to the accuracy of such information. Efforts are underway to better integrate information from third parties. TI has taken and continues to take reasonable steps to provide representative and accurate information but may not have conducted destructive testing or chemical analysis on incoming materials and chemicals. TI and TI suppliers consider certain information to be proprietary, and thus CAS numbers and other limited information may not be available for release.

In no event shall TI's liability arising out of such information exceed the total purchase price of the TI part(s) at issue in this document sold by TI to Customer on an annual basis.

TAPE AND REEL INFORMATION



QUADRANT ASSIGNMENTS FOR PIN 1 ORIENTATION IN TAPE



*All dimensions are nominal

Device	Package Type	Package Drawing	Pins	SPQ	Reel Diameter (mm)	Reel Width W1 (mm)	A0 (mm)	B0 (mm)	K0 (mm)	P1 (mm)	W (mm)	Pin1 Quadrant
SN74AVC6T622PWR	TSSOP	PW	20	2000	330.0	16.4	6.95	7.1	1.6	8.0	16.0	Q1
SN74AVC6T622RGYR	QFN	RGY	20	1000	180.0	12.4	3.8	4.8	1.6	8.0	12.0	Q1
SN74AVC6T622ZXYR	BGA MICROSTAR JUNIOR	ZXY	20	2500	330.0	12.4	2.8	3.3	1.0	4.0	12.0	Q2

TAPE AND REEL BOX DIMENSIONS



*All dimensions are nominal

Device	Package Type	Package Drawing	Pins	SPQ	Length (mm)	Width (mm)	Height (mm)
SN74AVC6T622PWR	TSSOP	PW	20	2000	346.0	346.0	33.0
SN74AVC6T622RGYR	QFN	RGY	20	1000	190.5	212.7	31.8
SN74AVC6T622ZXYR	BGA MICROSTAR JUNIOR	ZXY	20	2500	340.5	338.1	20.6

PW (R-PDSO-G**)

PLASTIC SMALL-OUTLINE PACKAGE

14 PINS SHOWN

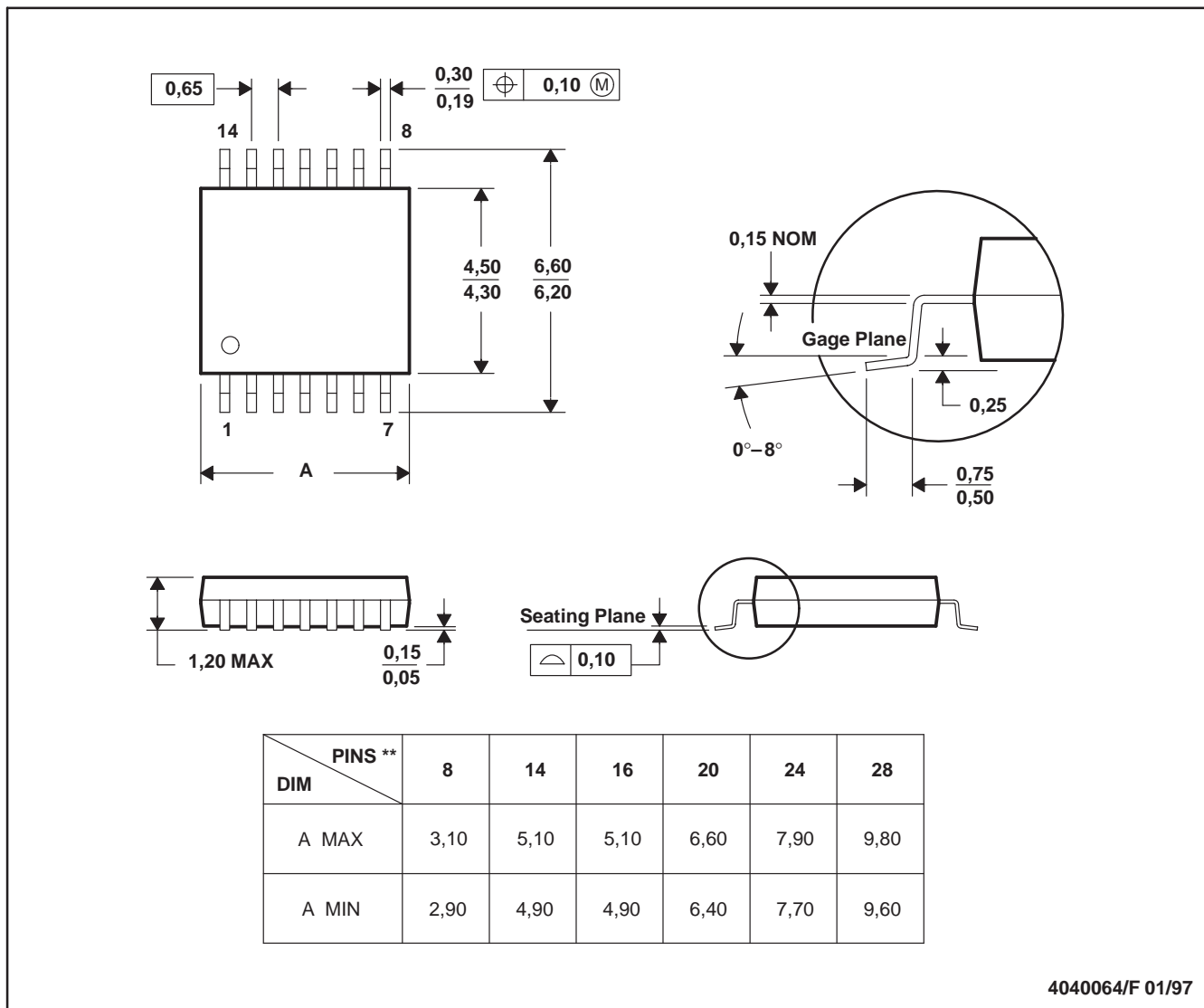

4040064/F 01/97

- NOTES: A. All linear dimensions are in millimeters.
 B. This drawing is subject to change without notice.
 C. Body dimensions do not include mold flash or protrusion not to exceed 0,15.
 D. Falls within JEDEC MO-153

RGY (R-PQFP-N20)

PLASTIC QUAD FLATPACK

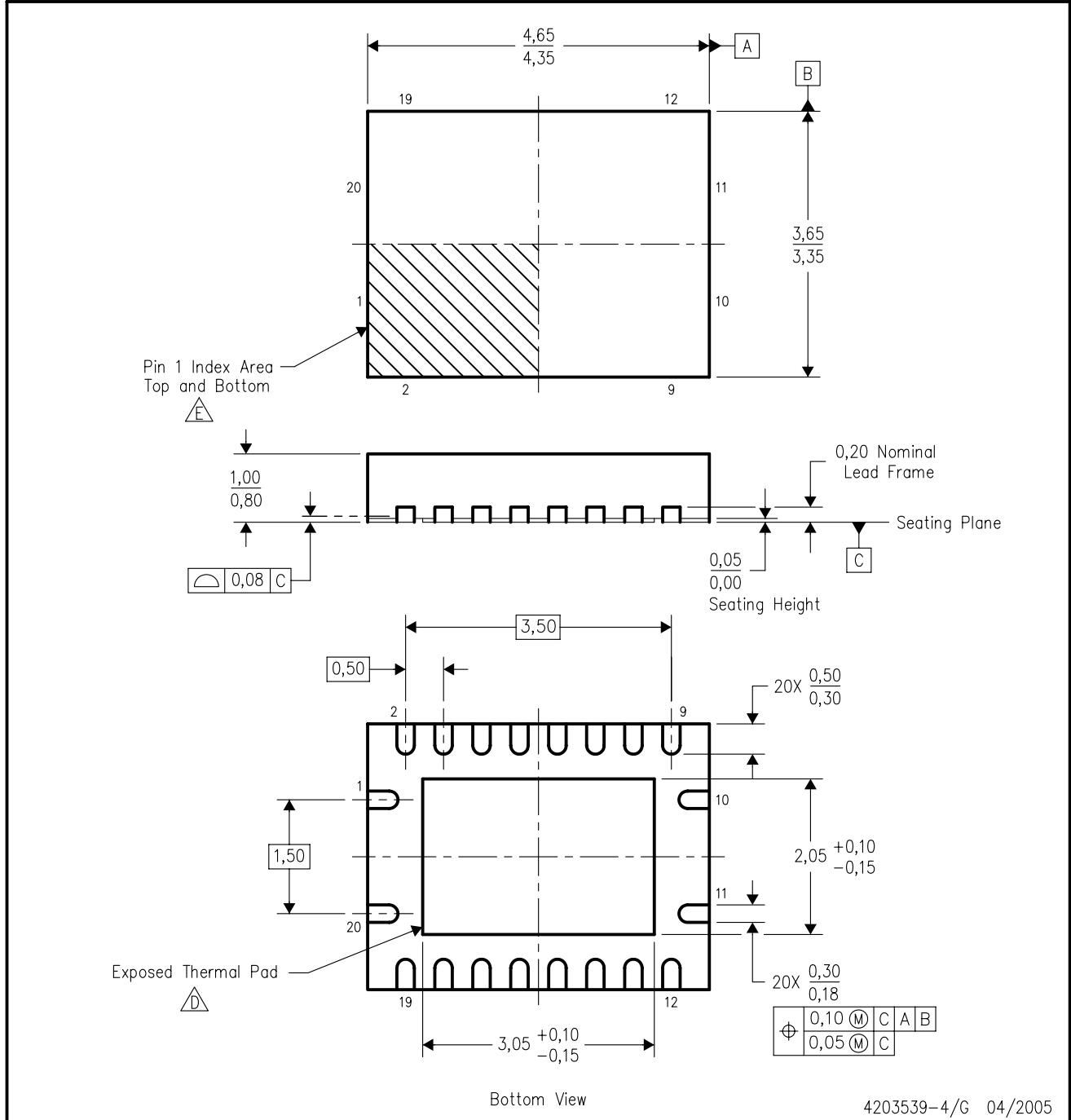

4203539-4/G 04/2005

- NOTES:
- A. All linear dimensions are in millimeters. Dimensioning and tolerancing per ASME Y14.5M-1994.
 - B. This drawing is subject to change without notice.
 - C. QFN (Quad Flatpack No-Lead) package configuration.
 - D. The package thermal pad must be soldered to the board for thermal and mechanical performance.
 - E. Pin 1 identifiers are located on both top and bottom of the package and within the zone indicated. The Pin 1 identifiers are either a molded, marked, or metal feature.
 - F. Package complies to JEDEC MO-241 variation BC.

THERMAL INFORMATION

This package incorporates an exposed thermal pad that is designed to be attached directly to an external heatsink. The thermal pad must be soldered directly to the printed circuit board (PCB). After soldering, the PCB can be used as a heatsink. In addition, through the use of thermal vias, the thermal pad can be attached directly to the appropriate copper plane shown in the electrical schematic for the device, or alternatively, can be attached to a special heatsink structure designed into the PCB. This design optimizes the heat transfer from the integrated circuit (IC).

For information on the Quad Flatpack No-Lead (QFN) package and its advantages, refer to Application Report, Quad Flatpack No-Lead Logic Packages, Texas Instruments Literature No. SCBA017. This document is available at www.ti.com.

The exposed thermal pad dimensions for this package are shown in the following illustration.

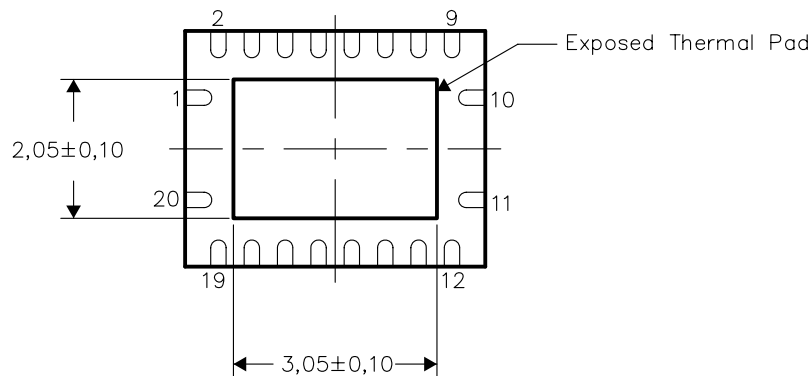

Bottom View

NOTE: All linear dimensions are in millimeters

Exposed Thermal Pad Dimensions

RGY (R-PQFP-N20)

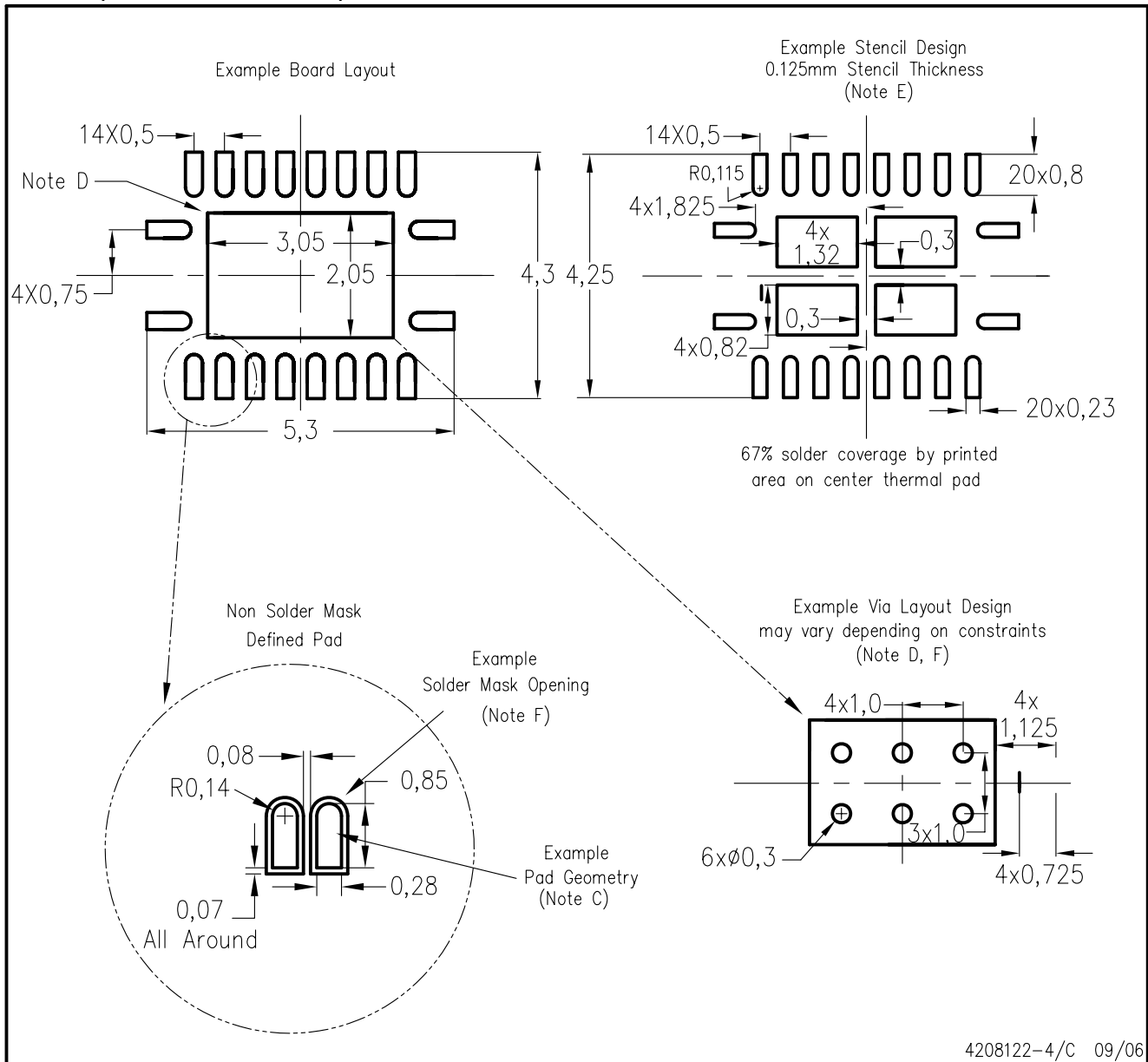

4208122-4/C 09/06

- NOTES:
- All linear dimensions are in millimeters.
 - This drawing is subject to change without notice.
 - Publication IPC-7351 is recommended for alternate designs.
 - This package is designed to be soldered to a thermal pad on the board. Refer to Application Note, Quad Flat-Pack Packages, Texas Instruments Literature No. SCBA017, SLUA271, and also the Product Data Sheets for specific thermal information, via requirements, and recommended board layout. These documents are available at www.ti.com <<http://www.ti.com>>.
 - Laser cutting apertures with trapezoidal walls and also rounding corners will offer better paste release. Customers should contact their board assembly site for stencil design recommendations. Refer to IPC 7525 for stencil design considerations.
 - Customers should contact their board fabrication site for minimum solder mask web tolerances between signal pads.

ZXY (S-PBGA-N20)

PLASTIC BALL GRID ARRAY

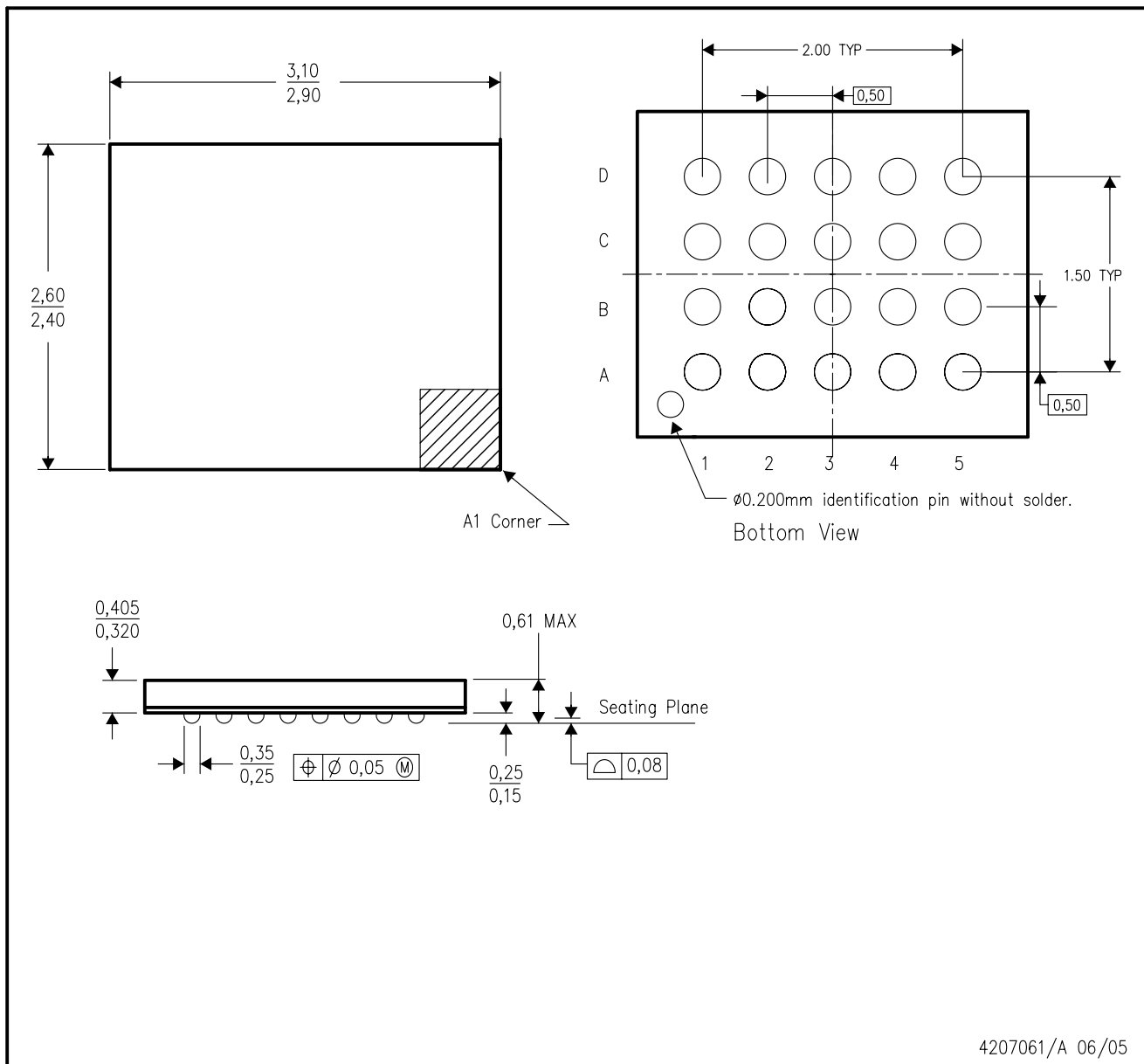

- NOTES:
- A. All linear dimensions are in millimeters.
 - B. This drawing is subject to change without notice.
 - C. This package is a lead-free solder ball design.

IMPORTANT NOTICE

Texas Instruments Incorporated and its subsidiaries (TI) reserve the right to make corrections, modifications, enhancements, improvements, and other changes to its products and services at any time and to discontinue any product or service without notice. Customers should obtain the latest relevant information before placing orders and should verify that such information is current and complete. All products are sold subject to TI's terms and conditions of sale supplied at the time of order acknowledgment.

TI warrants performance of its hardware products to the specifications applicable at the time of sale in accordance with TI's standard warranty. Testing and other quality control techniques are used to the extent TI deems necessary to support this warranty. Except where mandated by government requirements, testing of all parameters of each product is not necessarily performed.

TI assumes no liability for applications assistance or customer product design. Customers are responsible for their products and applications using TI components. To minimize the risks associated with customer products and applications, customers should provide adequate design and operating safeguards.

TI does not warrant or represent that any license, either express or implied, is granted under any TI patent right, copyright, mask work right, or other TI intellectual property right relating to any combination, machine, or process in which TI products or services are used. Information published by TI regarding third-party products or services does not constitute a license from TI to use such products or services or a warranty or endorsement thereof. Use of such information may require a license from a third party under the patents or other intellectual property of the third party, or a license from TI under the patents or other intellectual property of TI.

Reproduction of TI information in TI data books or data sheets is permissible only if reproduction is without alteration and is accompanied by all associated warranties, conditions, limitations, and notices. Reproduction of this information with alteration is an unfair and deceptive business practice. TI is not responsible or liable for such altered documentation. Information of third parties may be subject to additional restrictions.

Resale of TI products or services with statements different from or beyond the parameters stated by TI for that product or service voids all express and any implied warranties for the associated TI product or service and is an unfair and deceptive business practice. TI is not responsible or liable for any such statements.

TI products are not authorized for use in safety-critical applications (such as life support) where a failure of the TI product would reasonably be expected to cause severe personal injury or death, unless officers of the parties have executed an agreement specifically governing such use. Buyers represent that they have all necessary expertise in the safety and regulatory ramifications of their applications, and acknowledge and agree that they are solely responsible for all legal, regulatory and safety-related requirements concerning their products and any use of TI products in such safety-critical applications, notwithstanding any applications-related information or support that may be provided by TI. Further, Buyers must fully indemnify TI and its representatives against any damages arising out of the use of TI products in such safety-critical applications.

TI products are neither designed nor intended for use in military/aerospace applications or environments unless the TI products are specifically designated by TI as military-grade or "enhanced plastic." Only products designated by TI as military-grade meet military specifications. Buyers acknowledge and agree that any such use of TI products which TI has not designated as military-grade is solely at the Buyer's risk, and that they are solely responsible for compliance with all legal and regulatory requirements in connection with such use.

TI products are neither designed nor intended for use in automotive applications or environments unless the specific TI products are designated by TI as compliant with ISO/TS 16949 requirements. Buyers acknowledge and agree that, if they use any non-designated products in automotive applications, TI will not be responsible for any failure to meet such requirements.

Following are URLs where you can obtain information on other Texas Instruments products and application solutions:

Products

Amplifiers	amplifier.ti.com
Data Converters	dataconverter.ti.com
DSP	dsp.ti.com
Clocks and Timers	www.ti.com/clocks
Interface	interface.ti.com
Logic	logic.ti.com
Power Mgmt	power.ti.com
Microcontrollers	microcontroller.ti.com
RFID	www.ti-rfid.com
RF/IF and ZigBee® Solutions	www.ti.com/lprf

Applications

Audio	www.ti.com/audio
Automotive	www.ti.com/automotive
Broadband	www.ti.com/broadband
Digital Control	www.ti.com/digitalcontrol
Medical	www.ti.com/medical
Military	www.ti.com/military
Optical Networking	www.ti.com/opticalnetwork
Security	www.ti.com/security
Telephony	www.ti.com/telephony
Video & Imaging	www.ti.com/video
Wireless	www.ti.com/wireless

Mailing Address: Texas Instruments, Post Office Box 655303, Dallas, Texas 75265
Copyright © 2008, Texas Instruments Incorporated