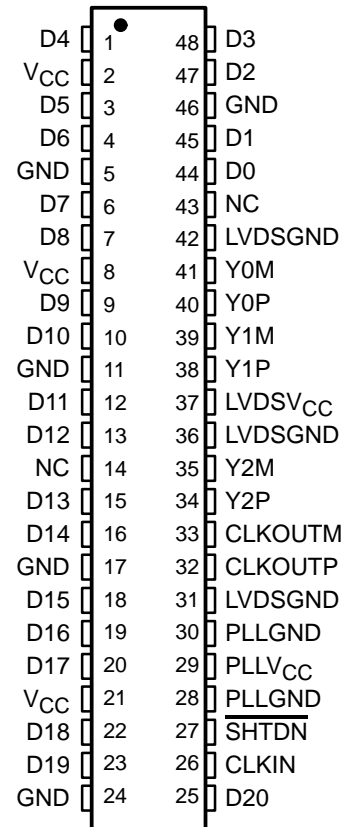


# SN75LVDS84A, SN65LVDS84AQ FLATLINK™ TRANSMITTER

SLLS354E – MAY 1999 – REVISED JANUARY 2001

- **21:3 Data Channel Compression at up to 196 Million Bytes per Second Throughput**
- **Suited for SVGA, XGA, or SXGA Data Transmission From Controller to Display With Very Low EMI**
- **21 Data Channels Plus Clock In Low-Voltage TTL Inputs and 3 Data Channels Plus Clock Out Low-Voltage Differential Signaling (LVDS) Outputs**
- **Operates From a Single 3.3-V Supply and 89 mW (Typ)**
- **Ultralow-Power 3.3-V CMOS Version of the SN75LVDS84. Power Consumption About One Third of the 'LVDS84**
- **Packaged in Thin Shrink Small-Outline Package (TSSOP) With 20 Mil Terminal Pitch**
- **Consumes Less Than 0.54 mW When Disabled**
- **Wide Phase-Lock Input Frequency Range: 31 MHz to 75 MHz**
- **No External Components Required for PLL**
- **Outputs Meet or Exceed the Requirements of ANSI EIA/TIA-644 Standard**
- **SSC Tracking Capability of 3% Center Spread at 50-kHz Modulation Frequency**
- **Improved Replacement for SN75LVDS84 and NSC's DS90CF363A 3-V Device**
- **Available in Q-Temp Automotive High Reliability Automotive Applications Configuration Control / Print Support Qualification to Automotive Standards**

**DGG PACKAGE  
(TOP VIEW)**



NC – Not Connected

## description

The SN75LVDS84A and SN65LVDS84AQ FlatLink transmitters contains three 7-bit parallel-load serial-out shift registers, and four low-voltage differential signaling (LVDS) line drivers in a single integrated circuit. These functions allow 21 bits of single-ended LVTTTL data to be synchronously transmitted over 3 balanced-pair conductors for receipt by a compatible receiver, such as the SN75LVDS82 or SN75LVDS86/86A.

When transmitting, data bits D0 – D20 are each loaded into registers of the 'LVDS84A upon the falling edge. The internal PLL is frequency-locked to CLKIN and then used to unload the data registers in 7-bit slices. The three serial streams and a phase-locked clock (CLKOUT) are then output to LVDS output drivers. The frequency of CLKOUT is the same as the input clock, CLKIN.



Please be aware that an important notice concerning availability, standard warranty, and use in critical applications of Texas Instruments semiconductor products and disclaimers thereto appears at the end of this data sheet.

FlatLink is a trademark of Texas Instruments.

PRODUCTION DATA information is current as of publication date. Products conform to specifications per the terms of Texas Instruments standard warranty. Production processing does not necessarily include testing of all parameters.



POST OFFICE BOX 655303 • DALLAS, TEXAS 75265

Copyright © 2001, Texas Instruments Incorporated

# SN75LVDS84A, SN65LVDS84AQ FLATLINK™ TRANSMITTER

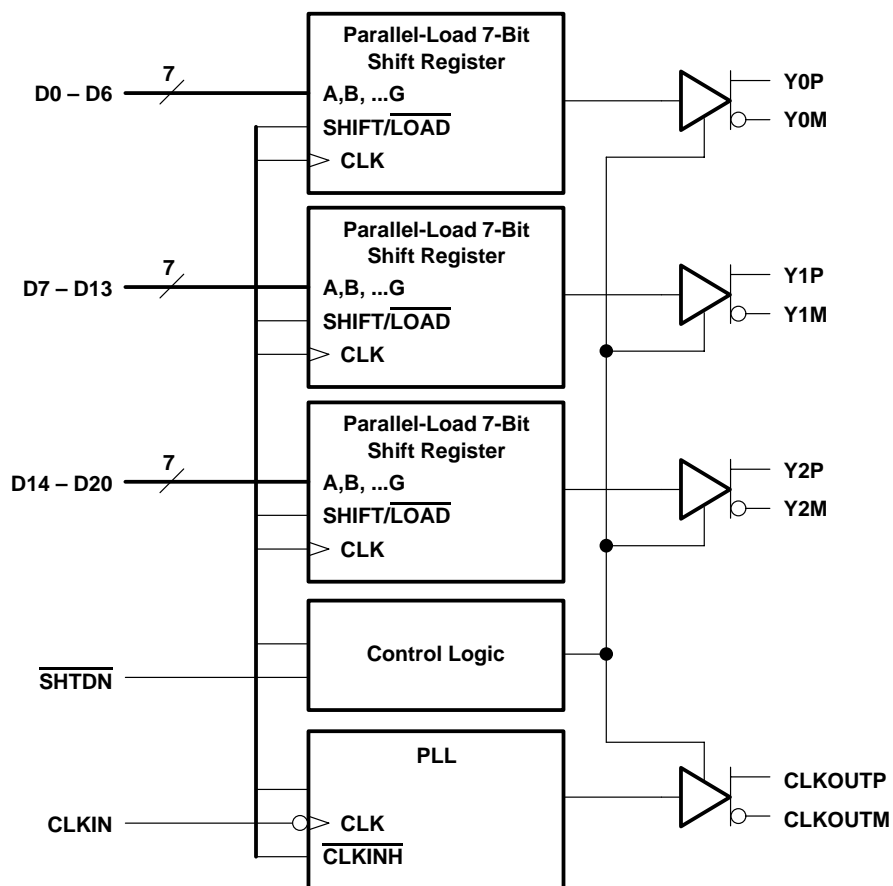
SLLS354E – MAY 1999 – REVISED JANUARY 2001

## description (continued)

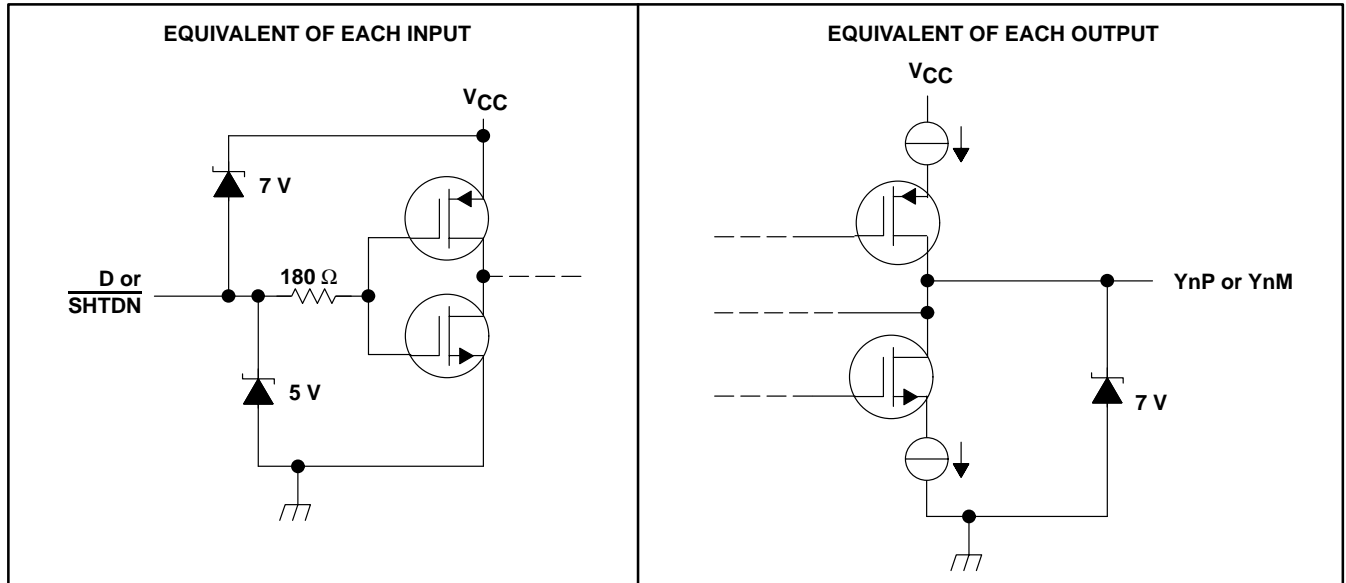
The 'LVDS84A requires no external components and little or no control. The data bus appears the same at the input to the transmitter and output of the receiver with the data transmission transparent to the user(s). The only user intervention is the possible use of the shutdown/clear ( $\overline{\text{SHTDN}}$ ) active-low input to inhibit the clock and shut off the LVDS output drivers for lower power consumption. A low-level on this signal clears all internal registers to a low level.

The SN75LVDS84A is characterized for operation over ambient free-air temperatures of 0°C to 70°C. The SN65LVDS84AQ is characterized for operation over the full Automotive temperature range of -40°C to 125°C.

## functional block diagram



schematics of input and output



absolute maximum ratings over operating free-air temperature (unless otherwise noted)†

Supply voltage range, $V_{CC}$ (see Note 1) .....	-0.5 V to 4 V
Input and output voltage ranges, $V_I$ , $V_O$ (all terminals) .....	-0.5 V to $V_{CC} + 0.5$ V
Continuous total power dissipation .....	See Dissipation Rating Table
Operating virtual junction temperature range, $T_J$ .....	-40°C to 150°C
Electrostatic discharge: ESD machine model .....	200 V
ESD human-body model .....	6000 V
ESD charged-device model .....	1500 V
Storage temperature range, $T_{stg}$ .....	-65°C to 150°C
Lead temperature 1,6 mm (1/16 inch) from case for 10 seconds .....	260°C

† Stresses beyond those listed under “absolute maximum ratings” may cause permanent damage to the device. These are stress ratings only, and functional operation of the device at these or any other conditions beyond those indicated under “recommended operating conditions” is not implied. Exposure to absolute-maximum-rated conditions for extended periods may affect device reliability.

NOTE 1: All voltage values are with respect to the GND terminals.

DISSIPATION RATING TABLE

PACKAGE	$T_A \leq 25^\circ\text{C}$ POWER RATING	DERATING FACTOR‡ ABOVE $T_A = 25^\circ\text{C}$	$T_A = 70^\circ\text{C}$ POWER RATING	$T_A = 125^\circ\text{C}$ POWER RATING
DGG	1637 mW	13.1 mW/°C	1048 mW	327 mW

‡ This is the inverse of the junction-to-ambient thermal resistance when board mounted and with no air flow.

recommended operating conditions

	MIN	NOM	MAX	UNIT
Supply voltage, $V_{CC}$	3	3.3	3.6	V
High-level input voltage, $V_{IH}$	2			V
Low-level input voltage, $V_{IL}$			0.8	V
Differential load impedance, $Z_L$	90		132	$\Omega$
Operating free-air temperature, $T_A$			0	°C
			70	
			-40	
			125	

# SN75LVDS84A, SN65LVDS84AQ FLATLINK™ TRANSMITTER

SLLS354E – MAY 1999 – REVISED JANUARY 2001

## timing requirements

	MIN	NOM	MAX	UNIT
$t_C$ Input clock period	13.3	$t_C$	32.4	ns
$t_W$ Pulse duration, high-level input clock	$0.4t_C$		$0.6t_C$	ns
$t_t$ Transition time, input signal			5	ns
$t_{SU}$ Setup time, data, D0 – D20 valid before CLKIN↓ (see Figure 2)	3			ns
$t_H$ Hold time, data, D0 – D20 valid after CLKIN↓ (see Figure 2)	1.5			ns

## electrical characteristics over recommended operating conditions (unless otherwise noted)

PARAMETER	TEST CONDITIONS	MIN	TYP†	MAX	UNIT
$V_{IT}$ Input threshold voltage			1.4		V
$ V_{OD} $ Differential steady-state output voltage magnitude	$R_L = 100 \Omega$ , See Figure 3	247		454	mV
$\Delta V_{OD} $ Change in the steady-state differential output voltage magnitude between opposite binary states				50	mV
$V_{OC(SS)}$ Steady-state common-mode output voltage	$R_L = 100 \Omega$ , See Figure 3	1.125		1.375	V
$V_{OC(PP)}$ Peak-to-peak common-mode output voltage			80	150	mV
$I_{IH}$ High-level input current	$V_{IH} = V_{CC}$	SN75LVDS84A		20	$\mu A$
		SN65LVDS84AQ		25	
$I_{IL}$ Low-level input current	$V_{IL} = 0$			$\pm 10$	$\mu A$
$I_{OS}$ Short-circuit output current	$V_O(Y_n) = 0$		-6	$\pm 24$	mA
	$V_{OD} = 0$		-6	$\pm 12$	
$I_{OZ}$ High-impedance output current	$V_O = 0$ to $V_{CC}$			$\pm 10$	$\mu A$
$I_{CC(AVG)}$ Quiescent supply current (average)	Disabled, All inputs at GND	SN75LVDS84A	15	150	$\mu A$
		SN65LVDS84AQ	15	170	
	Enabled, $R_L = 100 \Omega$ (4 places) Gray-scale pattern (see Figure 4)	$f = 65$ MHz	27	35	mA
		$f = 75$ MHz	30	38	
	Enabled, $R_L = 100 \Omega$ , (4 places) Worst-case pattern (see Figure 5)	$f = 65$ MHz	28	36	
		$f = 75$ MHz	31	39	
$C_I$ Input capacitance			2		pF

† All typical values are at  $V_{CC} = 3.3$  V,  $T_A = 25^\circ C$ .



switching characteristics over recommended operating conditions (unless otherwise noted)

PARAMETER		TEST CONDITIONS	MIN	TYP†	MAX	UNIT
t <sub>d0</sub>	Delay time, CLKOUT↑ to serial bit position 0	t <sub>c</sub> = 15.38 ns (± 0.2%),  Input clock jitter  < 50 ps‡, See Figure 6	-0.2		0.2	ns
t <sub>d1</sub>	Delay time, CLKOUT↑ to serial bit position 1		$\frac{1}{7}t_c - 0.2$		$\frac{1}{7}t_c + 0.2$	
t <sub>d2</sub>	Delay time, CLKOUT↑ to serial bit position 2		$\frac{2}{7}t_c - 0.2$		$\frac{2}{7}t_c + 0.2$	
t <sub>d3</sub>	Delay time, CLKOUT↑ to serial bit position 3		$\frac{3}{7}t_c - 0.2$		$\frac{3}{7}t_c + 0.2$	
t <sub>d4</sub>	Delay time, CLKOUT↑ to serial bit position 4		$\frac{4}{7}t_c - 0.2$		$\frac{4}{7}t_c + 0.2$	
t <sub>d5</sub>	Delay time, CLKOUT↑ to serial bit position 5		$\frac{5}{7}t_c - 0.2$		$\frac{5}{7}t_c + 0.2$	
t <sub>d6</sub>	Delay time, CLKOUT↑ to serial bit position 6		$\frac{6}{7}t_c - 0.2$		$\frac{6}{7}t_c + 0.2$	
t <sub>sk(o)</sub>	Output skew, t <sub>n</sub> - $\frac{n}{7}t_c$		-0.2		0.2	ns
t <sub>d7</sub>	Delay time, CLKIN↓ to CLKOUT↑	t <sub>c</sub> = 15.38 ns (± 0.2%),  Input clock jitter  < 50 ps‡, See Figure 6		2.7		ns
		t <sub>c</sub> = 13.33 ns ~ 32.25 ns (± 0.2%),  Input clock jitter  < 50 ps‡, See Figure 6	1		4.5	
Δt <sub>c(o)</sub>	Cycle time, output clock jitter§	t <sub>c</sub> = 15.38 + 0.308 sin (2π500E3t) ± 0.05 ns, See Figure 7		±62		ps
		t <sub>c</sub> = 15.38 + 0.308 sin (2π3E6t) ± 0.05 ns, See Figure 7		±121		
t <sub>w</sub>	Pulse duration, high-level output clock			$\frac{4}{7}t_c$		ns
t <sub>t</sub>	Transition time, differential output voltage (t <sub>r</sub> or t <sub>f</sub> )	See Figure 3		700	1500	ps
t <sub>en</sub>	Enable time, SHTDN↑ to phase lock (Y <sub>n</sub> valid)	See Figure 8		1		ms
t <sub>dis</sub>	Disable time, SHTDN↓ to off state (CLKOUT low)	See Figure 9		6.5		ns

† All typical values are at V<sub>CC</sub> = 3.3 V, T<sub>A</sub> = 25°C.

‡ |Input clock jitter| is the magnitude of the change in the input clock period.

§ Output clock jitter is the change in the output clock period from one cycle to the next cycle observed over 15000 cycles.

# SN75LVDS84A, SN65LVDS84AQ FLATLINK™ TRANSMITTER

SLLS354E – MAY 1999 – REVISED JANUARY 2001

## PARAMETER MEASUREMENT INFORMATION

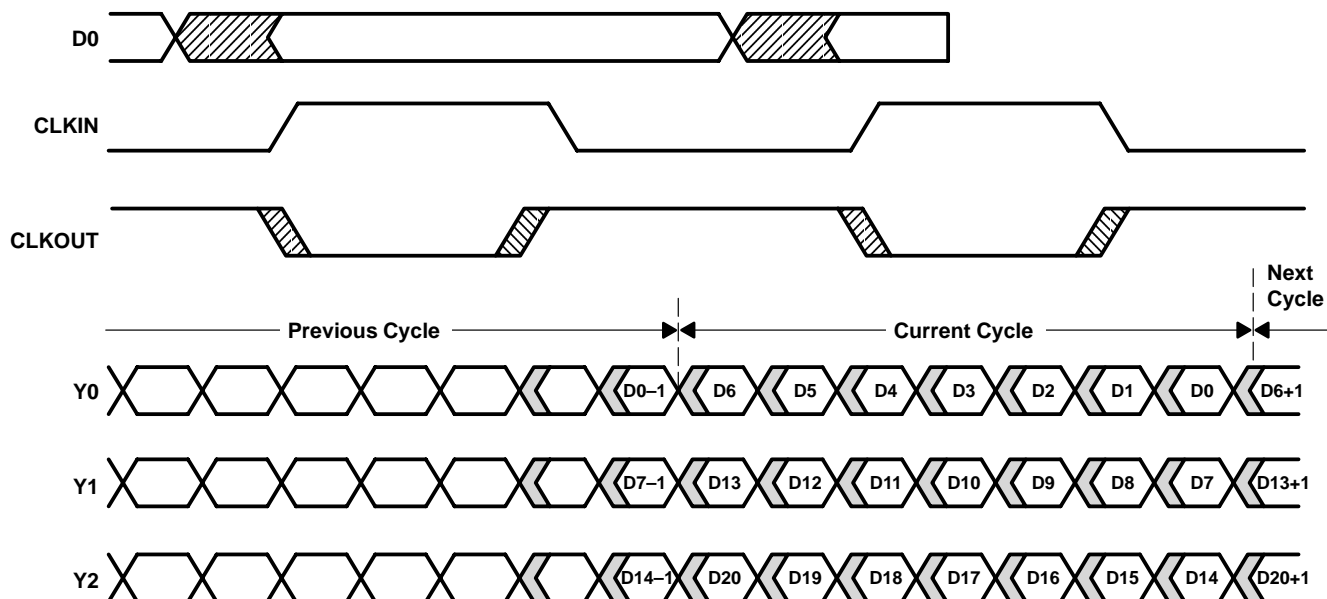
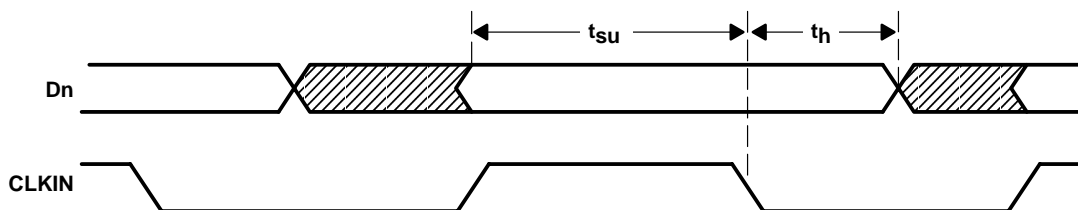
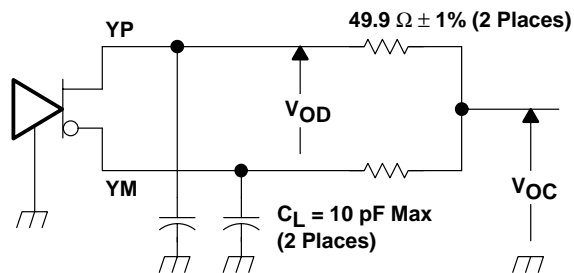


Figure 1. Typical Load and Shift Sequences



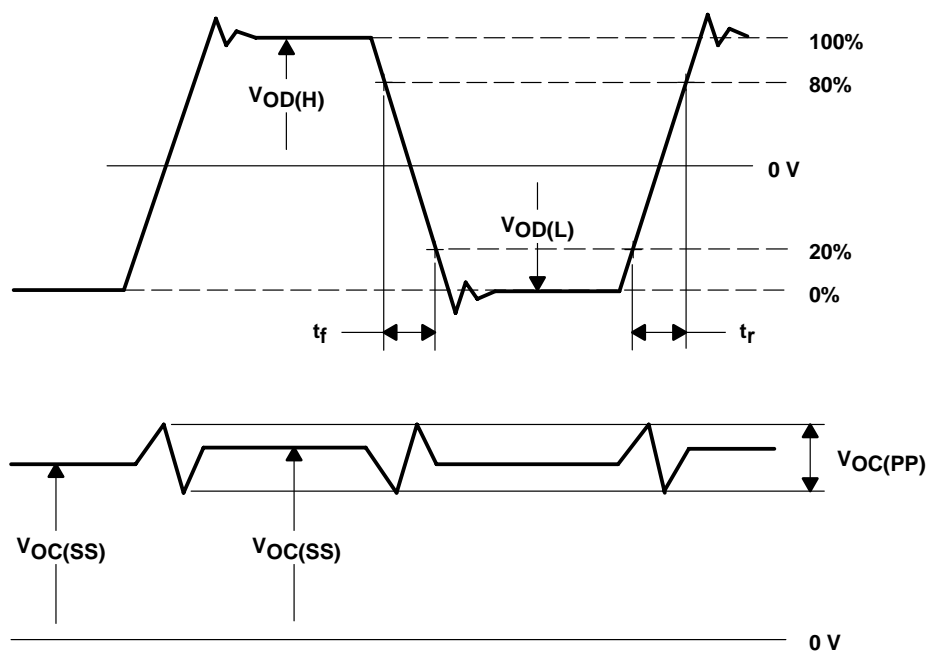
NOTE A: All input timing is defined at 1.4 V on an input signal with a 10%-to-90% rise or fall time of less than 5 ns.

Figure 2. Setup and Hold Time Definition



NOTE A: The lumped instrumentation capacitance for any single-ended voltage measurement is less than or equal to 10 pF. When making measurements at YP or YM, the complementary output is similarly loaded.

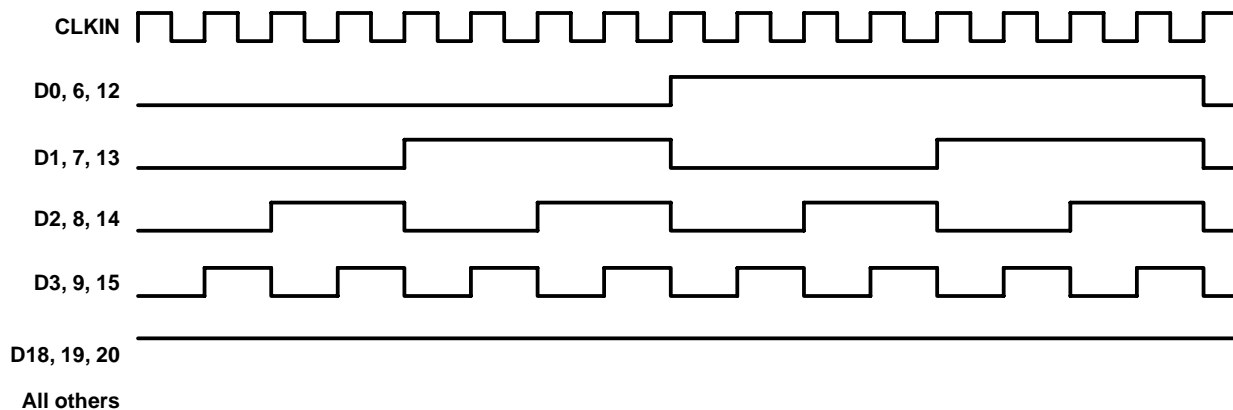
(a) SCHEMATIC



(b) WAVEFORMS

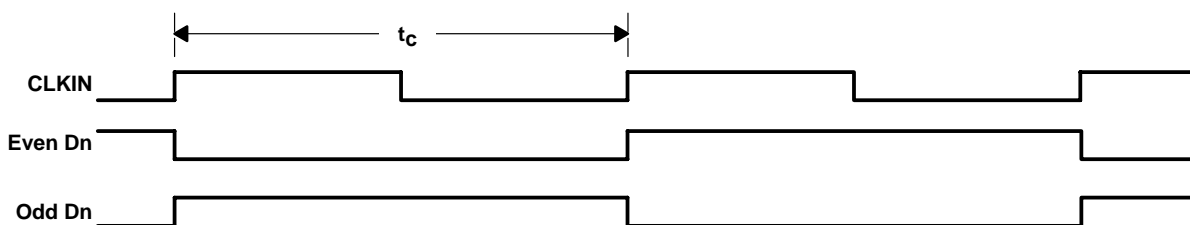
Figure 3. Test Load and Voltage Definitions for LVDS Outputs

**PARAMETER MEASUREMENT INFORMATION**



NOTES: A. The 16-grayscale test-pattern test device power consumption for a typical display pattern.  
 B.  $V_{IH} = 2\text{ V}$  and  $V_{IL} = 0.8\text{ V}$

**Figure 4. 16-Grayscale Test-Pattern Waveforms**



NOTES: A. The worst-case test pattern produces nearly the maximum switching frequency for all of the LVDS outputs.  
 B.  $V_{IH} = 2\text{ V}$  and  $V_{IL} = 0.8\text{ V}$

**Figure 5. Worst-Case Test-Pattern Waveforms**



PARAMETER MEASUREMENT INFORMATION

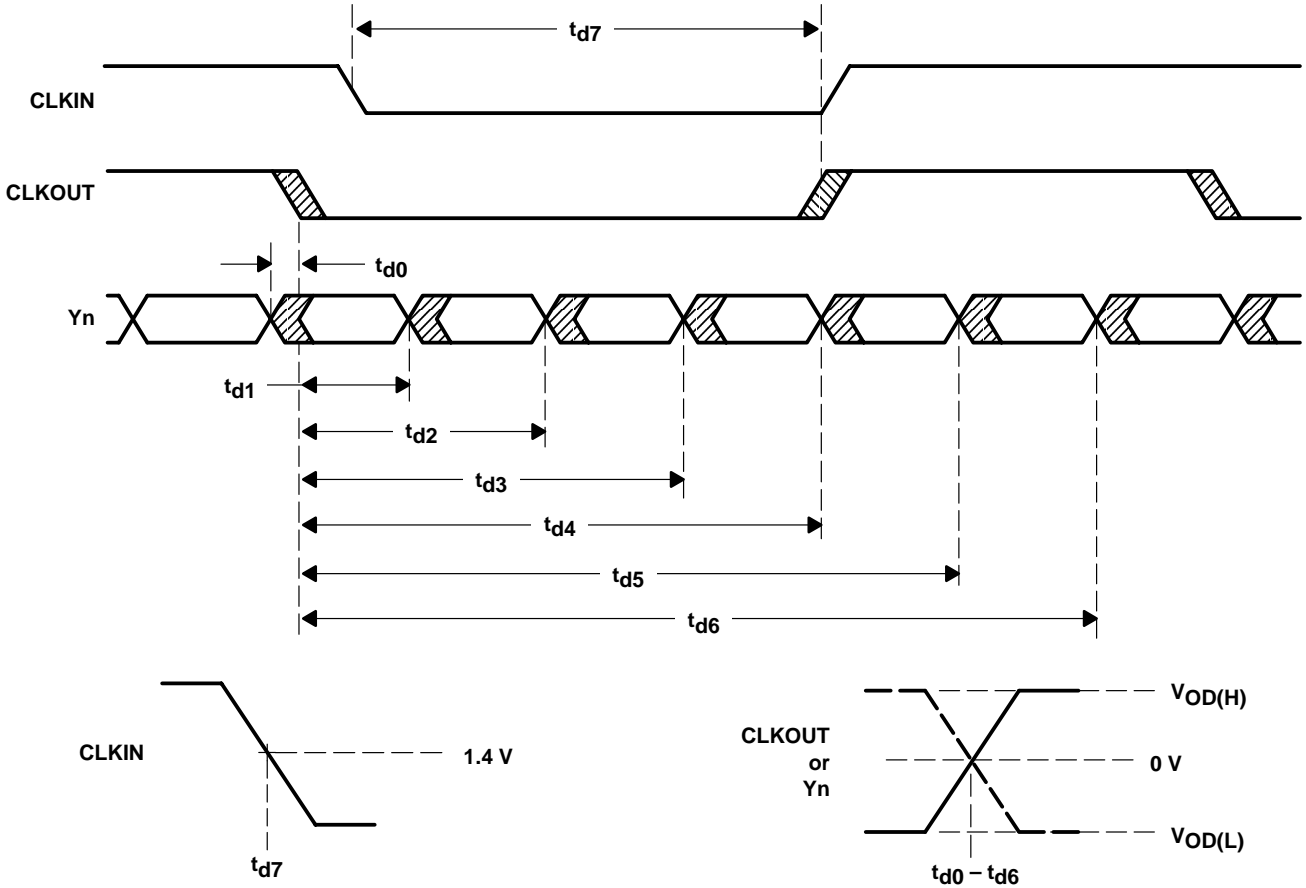


Figure 6. Timing Definitions

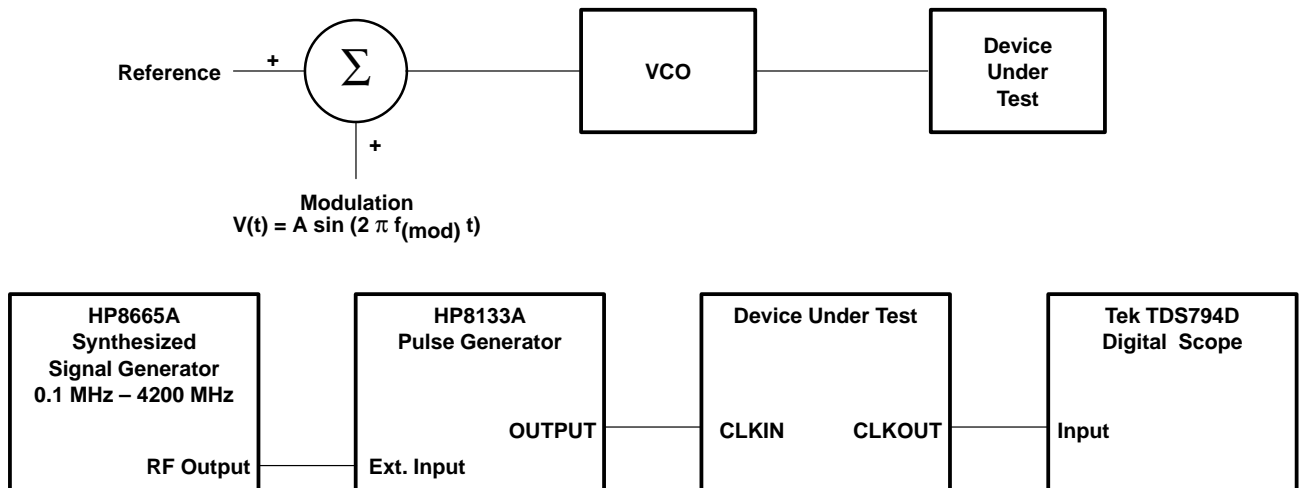
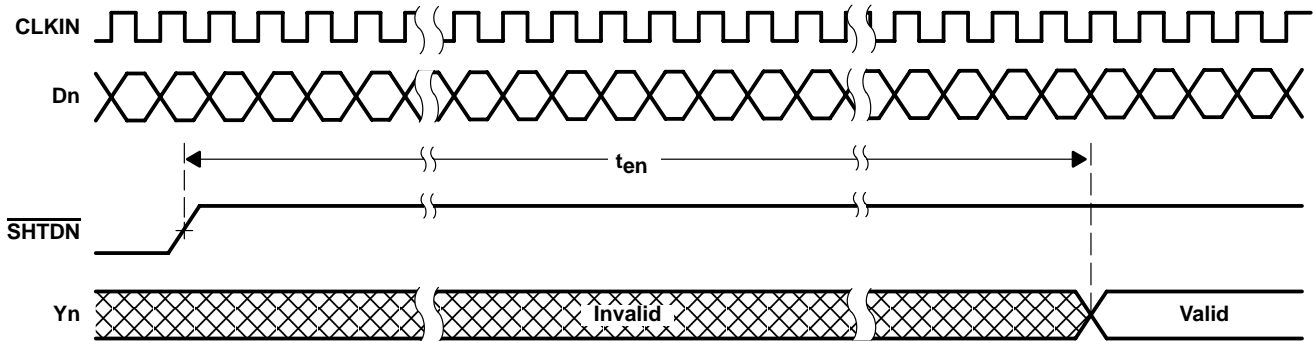
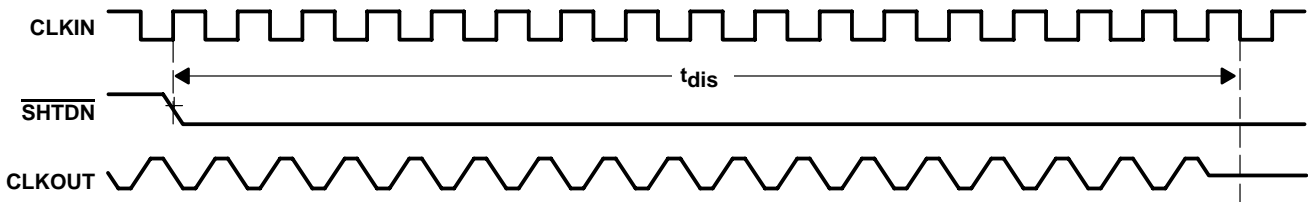


Figure 7. Clock Jitter Test Setup

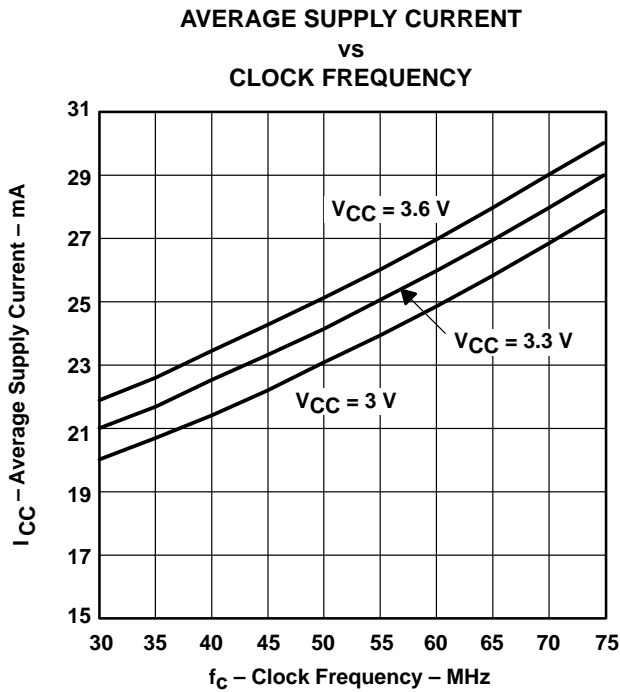
**TYPICAL CHARACTERISTICS**



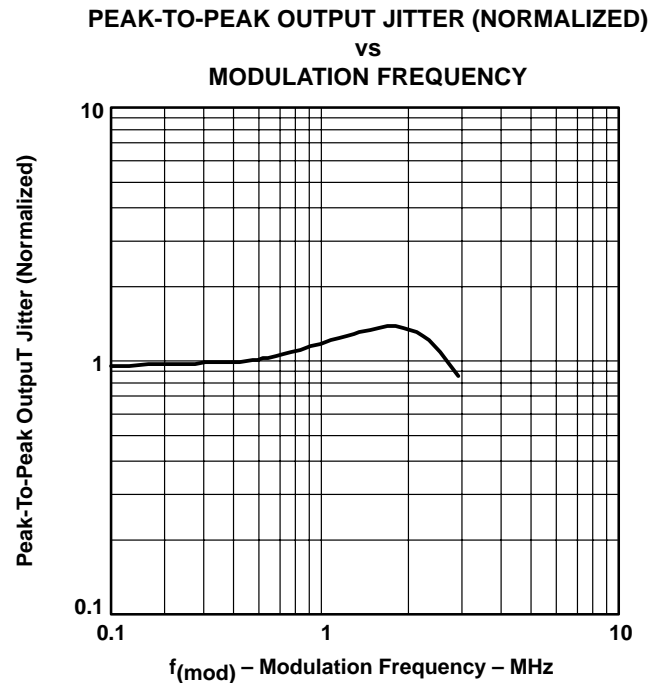
**Figure 8. Enable Time Waveforms**



**Figure 9. Disable Time Waveforms**

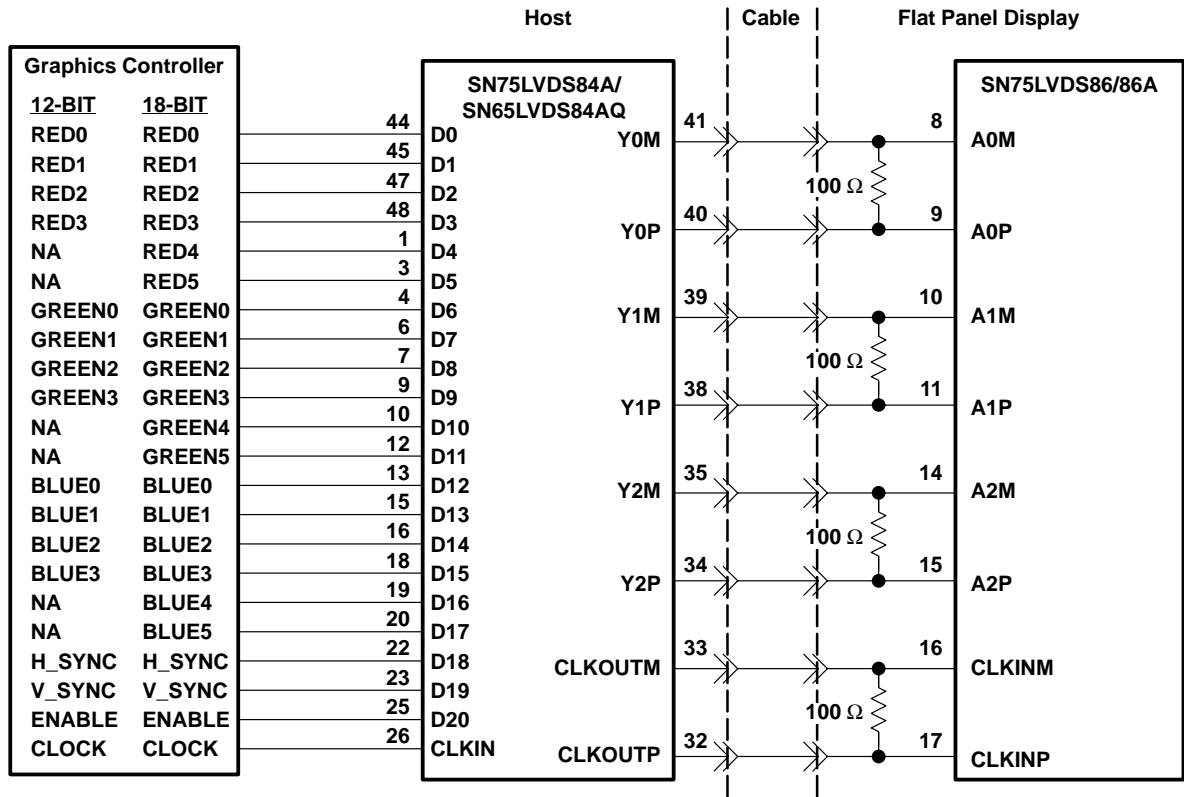


**Figure 10. Grayscale Input Pattern**



**Figure 11. Output Period Jitter vs Modulation Frequency**

APPLICATION INFORMATION



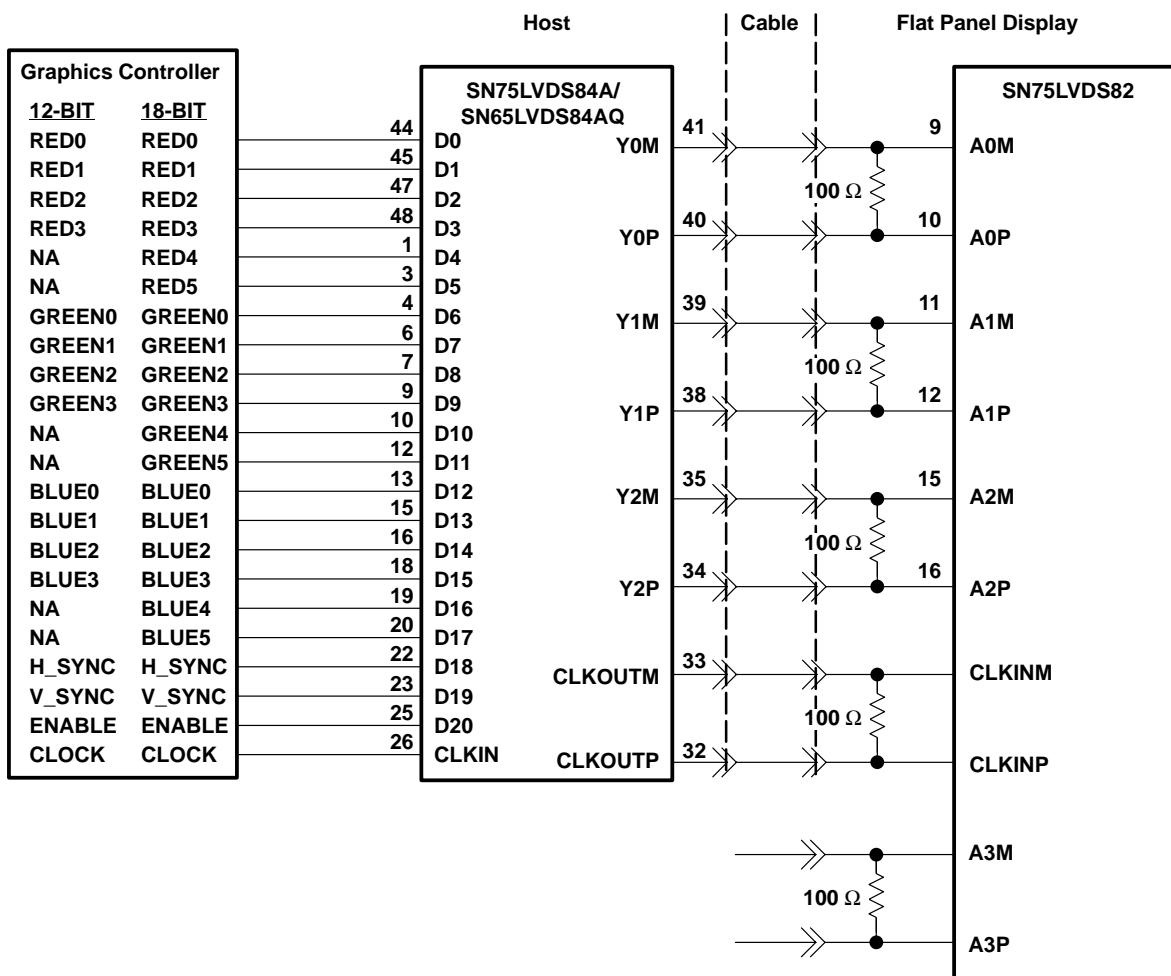
- NOTES: A. The five 100- $\Omega$  terminating resistors are recommended to be 0603 types.  
 B. NA – not applicable, these unused inputs should be left open.

Figure 12. Color Host to LCD Panel Application

# SN75LVDS84A, SN65LVDS84AQ FLATLINK™ TRANSMITTER

SLLS354E – MAY 1999 – REVISED JANUARY 2001

## APPLICATION INFORMATION



- NOTES: A. The four 100-Ω terminating resistors are recommended to be 0603 types.  
B. NA – not applicable, these unused inputs should be left open.

Figure 13. 18-Bit Color Host to 24-Bit LCD Display Panel Application

**PACKAGING INFORMATION**

Orderable Device	Status <sup>(1)</sup>	Package Type	Package Drawing	Pins	Package Qty	Eco Plan <sup>(2)</sup>	Lead/Ball Finish	MSL Peak Temp <sup>(3)</sup>
SN65LVDS84AQDGG	ACTIVE	TSSOP	DGG	48	40	Green (RoHS & no Sb/Br)	CU NIPDAU	Level-2-260C-1 YEAR
SN65LVDS84AQDGGR	ACTIVE	TSSOP	DGG	48	2000	Green (RoHS & no Sb/Br)	CU NIPDAU	Level-2-260C-1 YEAR
SN75LVDS84ADGG	ACTIVE	TSSOP	DGG	48	40	Green (RoHS & no Sb/Br)	CU NIPDAU	Level-2-260C-1 YEAR
SN75LVDS84ADGGG4	ACTIVE	TSSOP	DGG	48	40	Green (RoHS & no Sb/Br)	CU NIPDAU	Level-2-260C-1 YEAR
SN75LVDS84ADGGR	ACTIVE	TSSOP	DGG	48	2000	Green (RoHS & no Sb/Br)	CU NIPDAU	Level-2-260C-1 YEAR
SN75LVDS84ADGGRG4	ACTIVE	TSSOP	DGG	48	2000	Green (RoHS & no Sb/Br)	CU NIPDAU	Level-2-260C-1 YEAR

<sup>(1)</sup> The marketing status values are defined as follows:

**ACTIVE:** Product device recommended for new designs.

**LIFEBUY:** TI has announced that the device will be discontinued, and a lifetime-buy period is in effect.

**NRND:** Not recommended for new designs. Device is in production to support existing customers, but TI does not recommend using this part in a new design.

**PREVIEW:** Device has been announced but is not in production. Samples may or may not be available.

**OBSOLETE:** TI has discontinued the production of the device.

<sup>(2)</sup> Eco Plan - The planned eco-friendly classification: Pb-Free (RoHS), Pb-Free (RoHS Exempt), or Green (RoHS & no Sb/Br) - please check <http://www.ti.com/productcontent> for the latest availability information and additional product content details.

**TBD:** The Pb-Free/Green conversion plan has not been defined.

**Pb-Free (RoHS):** TI's terms "Lead-Free" or "Pb-Free" mean semiconductor products that are compatible with the current RoHS requirements for all 6 substances, including the requirement that lead not exceed 0.1% by weight in homogeneous materials. Where designed to be soldered at high temperatures, TI Pb-Free products are suitable for use in specified lead-free processes.

**Pb-Free (RoHS Exempt):** This component has a RoHS exemption for either 1) lead-based flip-chip solder bumps used between the die and package, or 2) lead-based die adhesive used between the die and leadframe. The component is otherwise considered Pb-Free (RoHS compatible) as defined above.

**Green (RoHS & no Sb/Br):** TI defines "Green" to mean Pb-Free (RoHS compatible), and free of Bromine (Br) and Antimony (Sb) based flame retardants (Br or Sb do not exceed 0.1% by weight in homogeneous material)

<sup>(3)</sup> MSL, Peak Temp. -- The Moisture Sensitivity Level rating according to the JEDEC industry standard classifications, and peak solder temperature.

**Important Information and Disclaimer:** The information provided on this page represents TI's knowledge and belief as of the date that it is provided. TI bases its knowledge and belief on information provided by third parties, and makes no representation or warranty as to the accuracy of such information. Efforts are underway to better integrate information from third parties. TI has taken and continues to take reasonable steps to provide representative and accurate information but may not have conducted destructive testing or chemical analysis on incoming materials and chemicals. TI and TI suppliers consider certain information to be proprietary, and thus CAS numbers and other limited information may not be available for release.

In no event shall TI's liability arising out of such information exceed the total purchase price of the TI part(s) at issue in this document sold by TI to Customer on an annual basis.

**TAPE AND REEL INFORMATION**
**REEL DIMENSIONS**

**TAPE DIMENSIONS**


A0	Dimension designed to accommodate the component width
B0	Dimension designed to accommodate the component length
K0	Dimension designed to accommodate the component thickness
W	Overall width of the carrier tape
P1	Pitch between successive cavity centers

**TAPE AND REEL INFORMATION**

\*All dimensions are nominal

Device	Package Type	Package Drawing	Pins	SPQ	Reel Diameter (mm)	Reel Width W1 (mm)	A0 (mm)	B0 (mm)	K0 (mm)	P1 (mm)	W (mm)	Pin1 Quadrant
SN65LVDS84AQDGGR	TSSOP	DGG	48	2000	330.0	24.4	8.6	15.8	1.8	12.0	24.0	Q1
SN75LVDS84ADGGR	TSSOP	DGG	48	2000	330.0	24.4	8.6	15.8	1.8	12.0	24.0	Q1

**TAPE AND REEL BOX DIMENSIONS**


\*All dimensions are nominal

Device	Package Type	Package Drawing	Pins	SPQ	Length (mm)	Width (mm)	Height (mm)
SN65LVDS84AQDGGR	TSSOP	DGG	48	2000	367.0	367.0	45.0
SN75LVDS84ADGGR	TSSOP	DGG	48	2000	367.0	367.0	45.0

DGG (R-PDSO-G\*\*)

PLASTIC SMALL-OUTLINE PACKAGE

48 PINS SHOWN



- NOTES: A. All linear dimensions are in millimeters.  
 B. This drawing is subject to change without notice.  
 C. Body dimensions do not include mold protrusion not to exceed 0,15.  
 D. Falls within JEDEC MO-153



## IMPORTANT NOTICE

Texas Instruments Incorporated and its subsidiaries (TI) reserve the right to make corrections, enhancements, improvements and other changes to its semiconductor products and services per JESD46C and to discontinue any product or service per JESD48B. Buyers should obtain the latest relevant information before placing orders and should verify that such information is current and complete. All semiconductor products (also referred to herein as "components") are sold subject to TI's terms and conditions of sale supplied at the time of order acknowledgment.

TI warrants performance of its components to the specifications applicable at the time of sale, in accordance with the warranty in TI's terms and conditions of sale of semiconductor products. Testing and other quality control techniques are used to the extent TI deems necessary to support this warranty. Except where mandated by applicable law, testing of all parameters of each component is not necessarily performed.

TI assumes no liability for applications assistance or the design of Buyers' products. Buyers are responsible for their products and applications using TI components. To minimize the risks associated with Buyers' products and applications, Buyers should provide adequate design and operating safeguards.

TI does not warrant or represent that any license, either express or implied, is granted under any patent right, copyright, mask work right, or other intellectual property right relating to any combination, machine, or process in which TI components or services are used. Information published by TI regarding third-party products or services does not constitute a license to use such products or services or a warranty or endorsement thereof. Use of such information may require a license from a third party under the patents or other intellectual property of the third party, or a license from TI under the patents or other intellectual property of TI.

Reproduction of significant portions of TI information in TI data books or data sheets is permissible only if reproduction is without alteration and is accompanied by all associated warranties, conditions, limitations, and notices. TI is not responsible or liable for such altered documentation. Information of third parties may be subject to additional restrictions.

Resale of TI components or services with statements different from or beyond the parameters stated by TI for that component or service voids all express and any implied warranties for the associated TI component or service and is an unfair and deceptive business practice. TI is not responsible or liable for any such statements.

Buyer acknowledges and agrees that it is solely responsible for compliance with all legal, regulatory and safety-related requirements concerning its products, and any use of TI components in its applications, notwithstanding any applications-related information or support that may be provided by TI. Buyer represents and agrees that it has all the necessary expertise to create and implement safeguards which anticipate dangerous consequences of failures, monitor failures and their consequences, lessen the likelihood of failures that might cause harm and take appropriate remedial actions. Buyer will fully indemnify TI and its representatives against any damages arising out of the use of any TI components in safety-critical applications.

In some cases, TI components may be promoted specifically to facilitate safety-related applications. With such components, TI's goal is to help enable customers to design and create their own end-product solutions that meet applicable functional safety standards and requirements. Nonetheless, such components are subject to these terms.

No TI components are authorized for use in FDA Class III (or similar life-critical medical equipment) unless authorized officers of the parties have executed a special agreement specifically governing such use.

Only those TI components which TI has specifically designated as military grade or "enhanced plastic" are designed and intended for use in military/aerospace applications or environments. Buyer acknowledges and agrees that any military or aerospace use of TI components which have **not** been so designated is solely at the Buyer's risk, and that Buyer is solely responsible for compliance with all legal and regulatory requirements in connection with such use.

TI has specifically designated certain components which meet ISO/TS16949 requirements, mainly for automotive use. Components which have not been so designated are neither designed nor intended for automotive use; and TI will not be responsible for any failure of such components to meet such requirements.

### Products

Audio	<a href="http://www.ti.com/audio">www.ti.com/audio</a>
Amplifiers	<a href="http://amplifier.ti.com">amplifier.ti.com</a>
Data Converters	<a href="http://dataconverter.ti.com">dataconverter.ti.com</a>
DLP® Products	<a href="http://www.dlp.com">www.dlp.com</a>
DSP	<a href="http://dsp.ti.com">dsp.ti.com</a>
Clocks and Timers	<a href="http://www.ti.com/clocks">www.ti.com/clocks</a>
Interface	<a href="http://interface.ti.com">interface.ti.com</a>
Logic	<a href="http://logic.ti.com">logic.ti.com</a>
Power Mgmt	<a href="http://power.ti.com">power.ti.com</a>
Microcontrollers	<a href="http://microcontroller.ti.com">microcontroller.ti.com</a>
RFID	<a href="http://www.ti-rfid.com">www.ti-rfid.com</a>
OMAP Mobile Processors	<a href="http://www.ti.com/omap">www.ti.com/omap</a>
Wireless Connectivity	<a href="http://www.ti.com/wirelessconnectivity">www.ti.com/wirelessconnectivity</a>

### Applications

Automotive and Transportation	<a href="http://www.ti.com/automotive">www.ti.com/automotive</a>
Communications and Telecom	<a href="http://www.ti.com/communications">www.ti.com/communications</a>
Computers and Peripherals	<a href="http://www.ti.com/computers">www.ti.com/computers</a>
Consumer Electronics	<a href="http://www.ti.com/consumer-apps">www.ti.com/consumer-apps</a>
Energy and Lighting	<a href="http://www.ti.com/energy">www.ti.com/energy</a>
Industrial	<a href="http://www.ti.com/industrial">www.ti.com/industrial</a>
Medical	<a href="http://www.ti.com/medical">www.ti.com/medical</a>
Security	<a href="http://www.ti.com/security">www.ti.com/security</a>
Space, Avionics and Defense	<a href="http://www.ti.com/space-avionics-defense">www.ti.com/space-avionics-defense</a>
Video and Imaging	<a href="http://www.ti.com/video">www.ti.com/video</a>

**TI E2E Community** [e2e.ti.com](http://e2e.ti.com)