

EMC OPTIMIZED CAN TRANSCEIVER

FEATURES

- Improved Replacement for the TJA1050
- High Electromagnetic Immunity (EMI)
- Very Low Electromagnetic Emissions (EME)
- Meets or Exceeds the Requirements of ISO 11898-2
- Bus-Fault Protection of -27 V to 40 V
- Dominant Time-Out Function
- Power-Up/Down Glitch-Free Bus Inputs and Outputs
 - High Input Impedance with Low V_{CC}
 - Monotonic Outputs During Power Cycling

APPLICATIONS

- Industrial Automation
 - DeviceNet™ Data Buses (Vendor ID #806)
- SAE J2284 High Speed CAN for Automotive Applications
- SAE J1939 Standard Data Bus Interface
- ISO 11783 Standard Data Bus Interface
- NMEA 2000 Standard Data Bus Interface

DESCRIPTION

The SN65HVD1050 meets or exceeds the specifications of the ISO 11898 standard for use in applications employing a Controller Area Network (CAN). The device is also qualified for use in automotive applications in accordance with AEC-Q100.⁽¹⁾

As a CAN transceiver, this device provides differential transmit capability to the bus and differential receive capability to a CAN controller at signaling rates up to 1 megabit per second (Mbps)⁽²⁾.

Designed for operation in especially harsh environments, the HVD1050 features cross-wire, over-voltage and loss of ground protection from -27 V to 40V, over-temperature shut down, a -12 V to 12 V common-mode range, and will withstand voltage transients from -200 V to 200 V according to ISO 7637.

(1) The device is available with Q100 qualification as the SN65HVD1050Q (PRODUCT PREVIEW).

(2) The signaling rate of a line is the number of voltage transitions that are made per second expressed in the units bps (bits per second).

FUNCTION BLOCK DIAGRAM

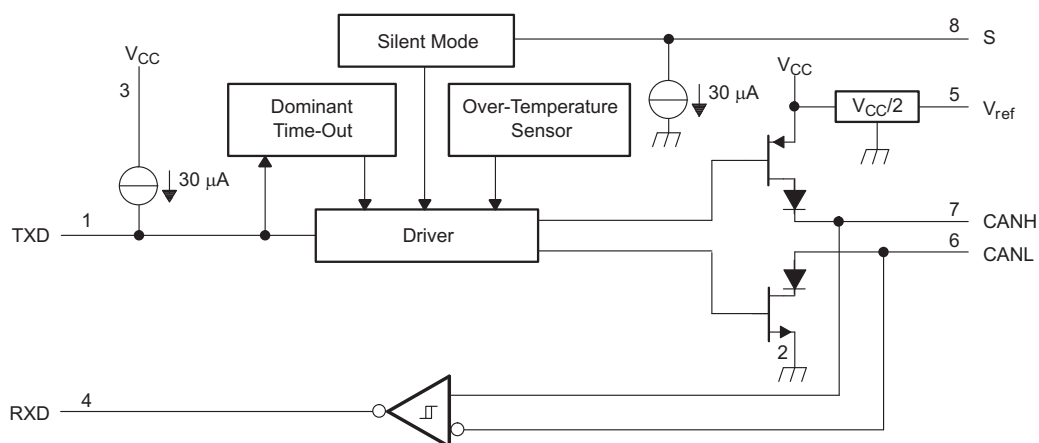

Please be aware that an important notice concerning availability, standard warranty, and use in critical applications of Texas Instruments semiconductor products and disclaimers thereto appears at the end of this data sheet.

DeviceNet is a trademark of Open DeviceNet Vendors Association, Inc.



These devices have limited built-in ESD protection. The leads should be shorted together or the device placed in conductive foam during storage or handling to prevent electrostatic damage to the MOS gates.

DESCRIPTION (CONTINUED)

Pin 8 provides for two different modes of operation: high-speed or silent mode. The high-speed mode of operation is selected by connecting S (pin 8) to ground.

If a high logic level is applied to the S pin of the SN65HVD1050, the device enters a listen-only silent mode during which the driver is switched off while the receiver remains fully functional.

In silent mode, all bus activity is passed by the receiver output to the local protocol controller. When data transmission is required, the local protocol controller reverses this low-current silent mode by placing a logic-low on the S pin to resume full operation.

A dominant-time-out circuit in the SN65HVD1050 prevents the driver from blocking network communication with a hardware or software failure. The time-out circuit is triggered by a falling edge on TXD (pin 1). If no rising edge is seen before the time-out constant of the circuit expires, the driver is disabled. The circuit is then reset by the next rising edge on TXD.

V_{ref} (pin 5) is available as a V_{CC}/2 voltage reference.

The SN65HVD1050 is characterized for operation from –40°C to 125°C.

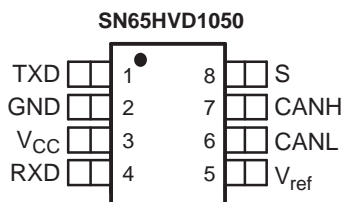

ORDERING INFORMATION

PART NUMBER	PACKAGE	MARKED AS	ORDERING NUMBER
SN65HVD1050	SOIC-8	VP1050	SN65HVD1050D (rail)
			SN65HVD1050DR (reel)

ABSOLUTE MAXIMUM RATINGS⁽¹⁾

	UNIT
V _{CC} Supply voltage ⁽²⁾	–0.3 V to 7 V
Voltage range at any bus terminal (CANH, CANL, V _{ref})	–27 V to 40 V
I _O Receiver output current	20 mA
V _I Voltage input, transient pulse ⁽³⁾ (CANH, CANL)	–200 V to 200 V
V _I Voltage input range (TXD, S)	–0.5 V to 6 V
T _J Junction temperature	–55°C to 170°C

- Stresses beyond those listed under "absolute maximum ratings" may cause permanent damage to the device. These are stress ratings only and functional operation of the device at these or any other conditions beyond those indicated under "recommended operating conditions" is not implied. Exposure to absolute-maximum-rated conditions for extended periods may affect device reliability.
- All voltage values, except differential I/O bus voltages, are with respect to network ground terminal.
- Tested in accordance with ISO 7637, test pulses 1, 2, 3a, 3b, 5, 6, and 7.

ELECTROSTATIC DISCHARGE PROTECTION⁽¹⁾

over operating free-air temperature range (unless otherwise noted)

PARAMETER	TEST CONDITIONS		VALUE
IEC Contact Discharge	IEC 61000-4-2	Bus terminals vs GND	±6 kV
Human Body Model	JEDEC Standard 22, Test Method A114-C.01	Bus terminals vs GND	±8 kV
		All pins	±4 kV
Field-Induced-Charged Device Model	JEDEC Standard 22, Test Method C101	All pins	±1.5 kV
Machine Model	ANSI/ESDS5.2-1996		±200 V

(1) All typical values at 25°C.

RECOMMENDED OPERATING CONDITIONS

			MIN	NOM	MAX	UNIT
V_{CC}	Supply voltage		4.75		5.25	V
V_I or V_{IC}	Voltage at any bus terminal (separately or common mode)		-12		12	V
V_{IH}	High-level input voltage	TXD, S	2		5.25	V
V_{IL}	Low-level input voltage		0		0.8	V
V_{ID}	Differential input voltage		-7		7	V
I_{OH}	High-level output current	Driver	-70			mA
		Receiver	-2			
I_{OL}	Low-level output current	Driver			70	mA
		Receiver			2	
T_J	Junction temperature	See <i>Thermal Characteristics</i> table, 1 Mbps minimum signaling rate with $R_L = 54\Omega$	-40		150	°C

SUPPLY CURRENT

over recommended operating conditions (unless otherwise noted)

PARAMETER		TEST CONDITIONS	MIN	TYP	MAX	UNIT	
I_{CC}	5-V Supply current	Silent mode		6	10	mA	
		Dominant	$V_I = 0$ V, 60 Ω Load, S at 0 V		50		70
		Recessive	$V_I = V_{CC}$, No Load, S at 0 V		6		10

DEVICE SWITCHING CHARACTERISTICS

over operating free-air temperature range (unless otherwise noted)

PARAMETER		TEST CONDITIONS	MIN	TYP	MAX	UNIT
$t_{d(LOOP1)}$	Total loop delay, driver input to receiver output, recessive to dominant	Figure 9, S at 0V	90		190	ns
$t_{d(LOOP2)}$	Total loop delay, driver input to receiver output, dominant to recessive		90		190	

DRIVER ELECTRICAL CHARACTERISTICS

over recommended operating conditions (unless otherwise noted)

PARAMETER		TEST CONDITIONS	MIN	TYP ⁽¹⁾	MAX	UNIT
$V_{O(D)}$	Bus output voltage (Dominant)	CANH	2.9	3.4	4.5	V
		CANL				
$V_{O(R)}$	Bus output voltage (Recessive)	$V_I = 3$ V, S at 0 V, $R_L = 60 \Omega$, See Figure 1 and Figure 2	2	2.3	3	V

(1) All typical values are at 25°C with a 5-V supply.

DRIVER ELECTRICAL CHARACTERISTICS (continued)

over recommended operating conditions (unless otherwise noted)

PARAMETER		TEST CONDITIONS	MIN	TYP ⁽¹⁾	MAX	UNIT
V _{OD(D)}	Differential output voltage (Dominant)	V _I = 0 V, R _L = 60 Ω, S at 0 V, See Figure 1 , Figure 2 , and Figure 3	1.5		3	V
		V _I = 0 V, R _L = 45 Ω, S at 0 V, See Figure 1 , Figure 2 , and Figure 3	1.4		3	V
V _{OD(R)}	Differential output voltage (Recessive)	V _I = 3 V, S at 0 V, See Figure 1 and Figure 2	-0.012		0.012	V
		V _I = 3 V, S at 0 V, No Load	-0.5		0.05	V
V _{OC(ss)}	Steady state common-mode output voltage	S at 0 V, Figure 8	2	2.3	3	V
ΔV _{OC(ss)}	Change in steady-state common-mode output voltage			30		mV
I _{IH}	High-level input current, TXD input	V _I at V _{CC}	-2		2	μA
I _{IL}	Low-level input current, TXD input	V _I at 0 V	-50		-10	
I _{O(off)}	Power-off TXD output current	V _{CC} at 0 V, TXD at 5 V			1	
I _{OS(ss)}	Short-circuit steady-state output current	V _{CANH} = -12 V, CANL Open, See Figure 11	-105	-72		mA
		V _{CANH} = 12 V, CANL Open, See Figure 11		0.36	1	
		V _{CANL} = -12 V, CANH Open, See Figure 11	-1	-0.5		
		V _{CANL} = 12 V, CANH Open, See Figure 11		71	105	
C _O	Output capacitance	See receiver input capacitance				

DRIVER SWITCHING CHARACTERISTICS

over recommended operating conditions (unless otherwise noted)

PARAMETER		TEST CONDITIONS	MIN	TYP	MAX	UNIT
t _{PLH}	Propagation delay time, low-to-high-level output	S at 0 V, See Figure 4	25	65	120	ns
t _{PHL}	Propagation delay time, high-to-low-level output		25	45	90	
t _r	Differential output signal rise time			25		
t _f	Differential output signal fall time			50		
t _{en}	Enable time from silent mode to dominant	See Figure 7			1	μs
t _(dom)	Dominant time-out	↓V _I , See Figure 10	300	450	700	μs

RECEIVER ELECTRICAL CHARACTERISTICS

over recommended operating conditions (unless otherwise noted)

PARAMETER		TEST CONDITIONS	MIN	TYP ⁽¹⁾	MAX	UNIT
V _{IT+}	Positive-going input threshold voltage	S at 0 V, See Table 1		800	900	mV
V _{IT-}	Negative-going input threshold voltage		500	650		
V _{hys}	Hysteresis voltage (V _{IT+} - V _{IT-})		100	125		
V _{OH}	High-level output voltage	I _O = -2 mA, See Figure 6	4	4.6		V
V _{OL}	Low-level output voltage	I _O = 2 mA, See Figure 6		0.2	0.4	V
I _{I(off)}	Power-off bus input current	CANH or CANL = 5 V, Other pin at 0 V, V _{CC} at 0 V, TXD at 0 V		165	250	μA
I _{O(off)}	Power-off RXD leakage current	V _{CC} at 0 V, RXD at 5 V			20	μA
C _I	Input capacitance to ground, (CANH or CANL)	TXD at 3 V, V _I = 0.4 sin(4E6πt) + 2.5 V		13		pF
C _{ID}	Differential input capacitance	TXD at 3 V, V _I = 0.4 sin(4E6πt)		5		
R _{ID}	Differential input resistance	TXD at 3 V, S at 0 V	30		80	kΩ
R _{IN}	Input resistance, (CANH or CANL)		15	30	40	

(1) All typical values are at 25°C with a 5-V supply.

RECEIVER ELECTRICAL CHARACTERISTICS (continued)

over recommended operating conditions (unless otherwise noted)

PARAMETER		TEST CONDITIONS	MIN	TYP ⁽¹⁾	MAX	UNIT
$R_{I(m)}$	Input resistance matching [1 – (R _{IN (CANH)} / R _{IN (CANL)})] x 100%	V _(CANH) = V _(CANL)	–3%	0%	3%	

RECEIVER SWITCHING CHARACTERISTICS

over recommended operating conditions (unless otherwise noted)

PARAMETER		TEST CONDITIONS	MIN	TYP	MAX	UNIT
t _{PLH}	Propagation delay time, low-to-high-level output	S at 0 V or V _{CC} . See Figure 6	60	100	130	ns
t _{PHL}	Propagation delay time, high-to-low-level output		45	70	90	ns
t _r	Output signal rise time		8			ns
t _f	Output signal fall time		8			ns

S-PIN CHARACTERISTICS

over recommended operating conditions (unless otherwise noted)

PARAMETER		TEST CONDITIONS	MIN	TYP	MAX	UNIT
I _{IH}	High level input current	S at 2 V	20	40	70	μA
I _{IL}	Low level input current	S at 0.8 V	5	20	30	

VREF-PIN CHARACTERISTICS

over operating free-air temperature range (unless otherwise noted)

PARAMETER		TEST CONDITIONS	MIN	TYP	MAX	UNIT
V _O	Reference output voltage	–50 μA < I _O < 50 μA	0.4 V _{CC}	0.5 V _{CC}	0.6 V _{CC}	V

THERMAL CHARACTERISTICS

over operating free-air temperature range (unless otherwise noted)

PARAMETER		TEST CONDITIONS	MIN	TYP	MAX	UNIT
θ _{JA}	Junction-to-Air	Low-K thermal resistance ⁽¹⁾		211		°C/W
		High-K thermal resistance		131		
θ _{JB}	Junction-to-Board Thermal Resistance			53		
θ _{JC}	Junction-to-Case Thermal Resistance			79		
P _D	Average power dissipation	V _{CC} = 5.0 V, T _j = 27°C, R _L = 60 Ω, S at 0 V, Input to TXD a 500 kHz, 50% duty cycle square wave. CL at RXD = 15 pF		112		mW
		V _{CC} = 5.5 V, T _j = 130°C, R _L = 45 Ω, S at 0 V, Input to TXD a 500 kHz, 50% duty cycle square wave. CL at RXD = 15 pF			170	
T _{J_shutdown}	Junction temperature, thermal shutdown ⁽²⁾			190		°C

(1) Tested in accordance with the Low-K or High-K thermal metric definitions of EIA/JESD51-3 for leaded surface-mount packages.

(2) Extended operation in thermal shutdown may affect device reliability, see APPLICATIONS INFORMATION.

FUNCTION TABLES

DRIVER

INPUTS		OUTPUTS		BUS STATE
TXD ⁽¹⁾	S ⁽¹⁾	CANH ⁽¹⁾	CANL ⁽¹⁾	
L	L or Open	H	L	DOMINANT
H	X	Z	Z	RECESSIVE
Open	X	Z	Z	RECESSIVE
X	H	Z	Z	RECESSIVE

(1) H = high level; L = low level; X = irrelevant; ? = indeterminate; Z = high impedance

RECEIVER

DIFFERENTIAL INPUTS $V_{ID} = V(CANH) - V(CANL)$	OUTPUT RXD ⁽¹⁾	BUS STATE
$V_{ID} \geq 0.9\text{ V}$	L	DOMINANT
$0.5\text{ V} < V_{ID} < 0.9\text{ V}$?	?
$V_{ID} \leq 0.5\text{ V}$	H	RECESSIVE
Open	H	RECESSIVE

(1) H = high level; L = low level; X = irrelevant; ? = indeterminate; Z = high impedance

PARAMETER MEASUREMENT INFORMATION

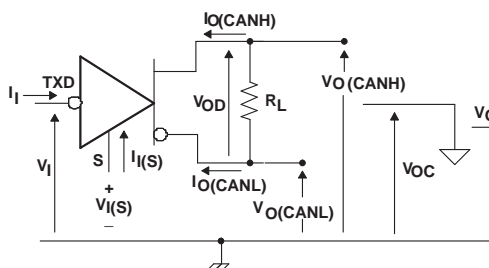

Figure 1. Driver Voltage, Current, and Test Definition

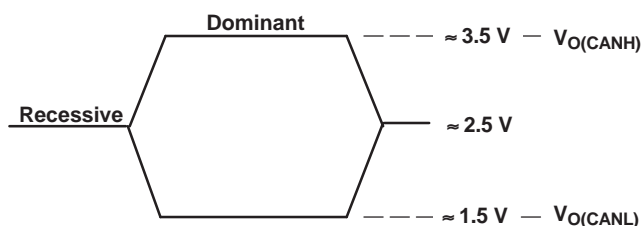

Figure 2. Bus Logic State Voltage Definitions

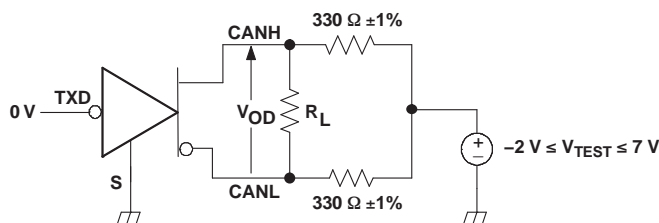

Figure 3. Driver V_{OD} Test Circuit

PARAMETER MEASUREMENT INFORMATION (continued)

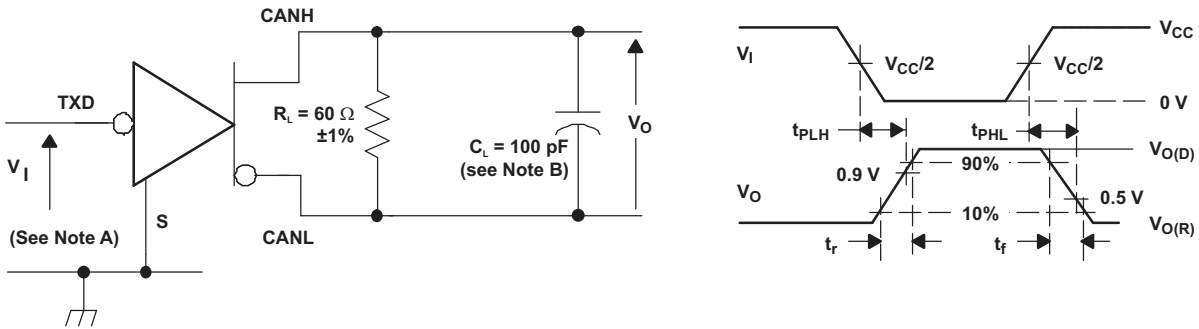

Figure 4. Driver Test Circuit and Voltage Waveforms

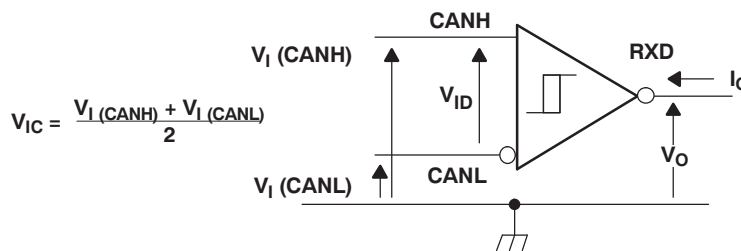
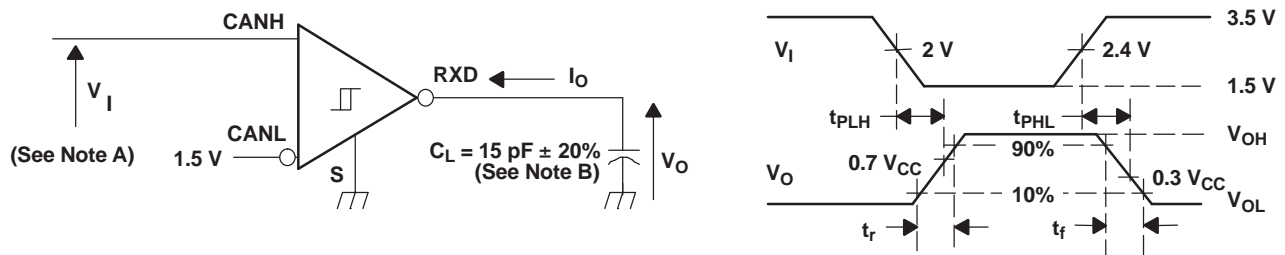

Figure 5. Receiver Voltage and Current Definitions



- A. The input pulse is supplied by a generator having the following characteristics: PRR ≤ 125 kHz, 50% duty cycle, tr ≤ 6 ns, tf ≤ 6ns, ZO = 50 Ω.
- B. CL includes instrumentation and fixture capacitance within 20%.

Figure 6. Receiver Test Circuit and Voltage Waveforms

Table 1. Differential Input Voltage Threshold Test

INPUT			OUTPUT	
V _{CANH}	V _{CANL}	V _{ID}	R	
-11.1 V	-12 V	900 mV	L	V _{OL}
12 V	11.1 V	900 mV	L	
-6 V	-12 V	6 V	L	
12 V	6 V	6 V	L	V _{OH}
-11.5 V	-12 V	500 mV	H	
12 V	11.5 V	500 mV	H	
-12 V	-6 V	6 V	H	
6 V	12 V	6 V	H	
Open	Open	X	H	

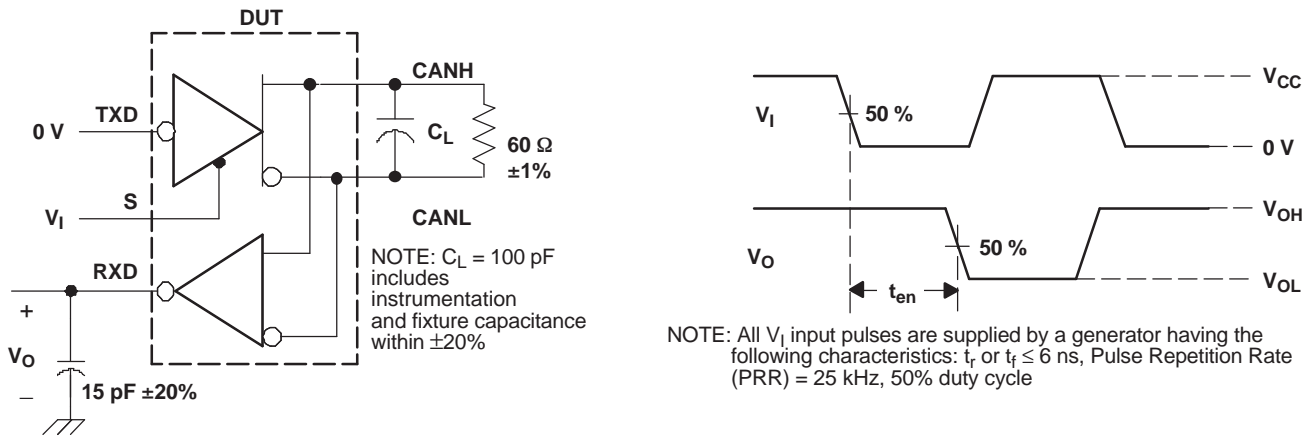
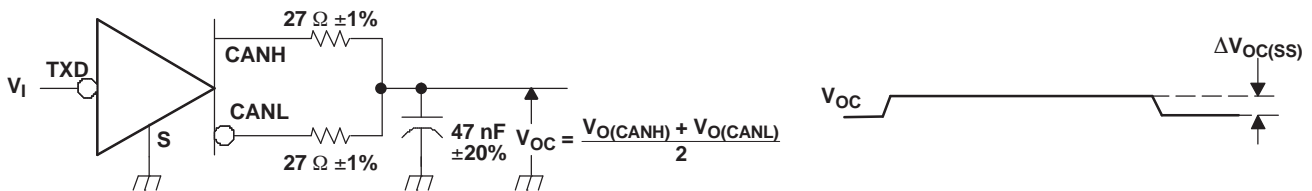
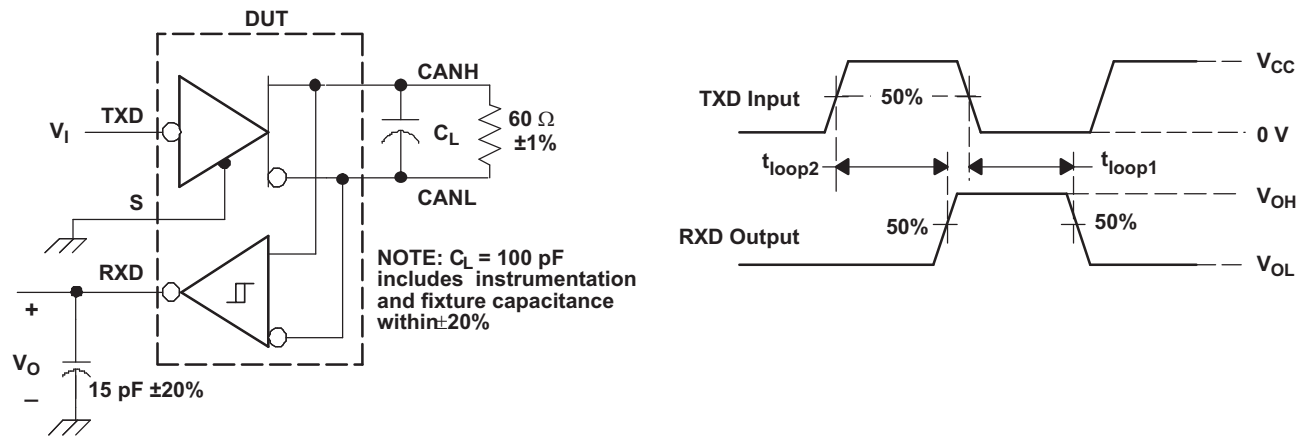

Figure 7. t_{en} Test Circuit and Waveform



NOTE: All V_I input pulses are from 0 V to V_{CC} and supplied by a generator having the following characteristics: t_r or $t_f \leq 6 \text{ ns}$. Pulse Repetition Rate (PRR) = 125 kHz, 50% duty cycle.

Figure 8. Common Mode Output Voltage Test and Waveforms



A. All V_I input pulses are from 0 V to V_{CC} and supplied by a generator having the following characteristics: t_r or $t_f \leq 6 \text{ ns}$. Pulse Repetition Rate (PRR) = 125 kHz, 50% duty cycle.

Figure 9. $t_{(LOOP)}$ Test Circuit and Waveform

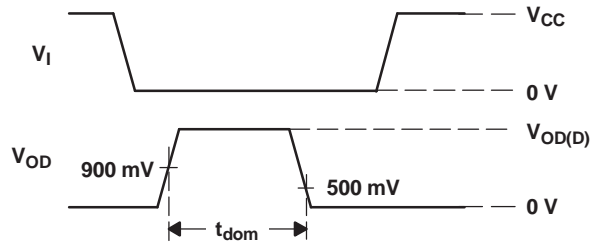
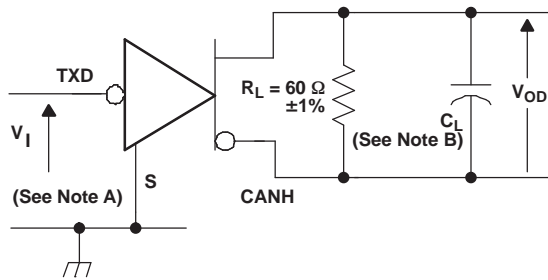

- A. All V_I input pulses are from 0 V to V_{CC} and supplied by a generator having the following characteristics: t_r or $t_f \leq 6$ ns. Pulse Repetition Rate (PRR) = 500 Hz, 50% duty cycle.
- B. $C_L = 100$ pF includes instrumentation and fixture capacitance within $\pm 20\%$.

Figure 10. Dominant Time-Out Test Circuit and Waveforms

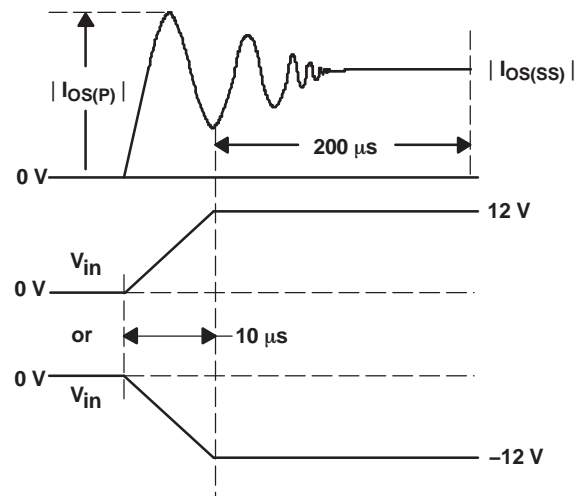
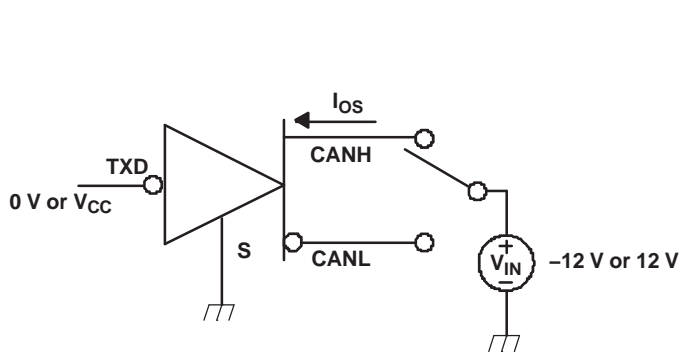

Figure 11. Driver Short-Circuit Current Test and Waveform

DEVICE INFORMATION

Table 2. Parametric Cross Reference With the TJA1050

TJA1050 ⁽¹⁾	PARAMETER	HVD1050
TRANSMITTER SECTION		
V_{IH}	High-level input voltage	Recommended V_{IH}
V_{IL}	Low-level input voltage	Recommended V_{IL}
I_{IH}	High-level input current	Driver I_{IH}
I_{IL}	Low-level input current	Driver I_{IL}
BUS SECTION		
I_{LI}	Power-off bus input current	Receiver $I_{I(off)}$
$I_{O(SC)}$	Short-circuit output current	Driver $I_{OS(SS)}$
$V_{O(dom)}$	Dominant output voltage	Driver $V_{O(D)}$
$V_{i(dif)(th)}$	Differential input voltage	Receiver V_{IT} and recommended V_{ID}
$V_{i(dif)(hys)}$	Differential input hysteresis	Receiver V_{hys}
$V_{O(reces)}$	Recessive output voltage	Driver $V_{O(R)}$
$V_{O(dif)(bus)}$	Differential bus voltage	Driver $V_{OD(D)}$ and $V_{OD(R)}$
$R_{i(cm)}$	CANH, CANL input resistance	Receiver R_{IN}
$R_{i(dif)}$	Differential input resistance	Receiver R_{ID}
$R_{i(cm)(m)}$	Input resistance matching	Receiver $R_{I(m)}$
C_i	Input capacitance to ground	Receiver C_I
$C_{i(dif)}$	Differential input capacitance	Receiver C_{ID}
RECEIVER SECTION		
I_{OH}	High-level output current	Recommended I_{OH}
I_{OL}	Low-level output current	Recommended I_{OL}
Vref PIN SECTION		
V_{ref}	Reference output voltage	V_O
TIMING SECTION		
$t_d(TXD-BUSon)$	Delay TXD to bus active	Driver t_{PLH}
$t_d(TXD-BUSoff)$	Delay TXD to bus inactive	Driver t_{PHL}
$t_d(BUSon-RXD)$	Delay bus active to RXD	Receiver t_{PHL}
$t_d(BUSoff-RXD)$	Delay bus inactive to RXD	Receiver t_{PLH}
	$t_d(TXD-BUSon) + t_d(BUSon-RXD)$	Device t_{LOOP1}
	$t_d(TXD-BUSoff) + t_d(BUSoff-RXD)$	Device t_{LOOP2}
$t_{dom}(TXD)$	Dominant time out	Driver $t_{(dom)}$
S PIN SECTION		
V_{IH}	High-level input voltage	Recommended V_{IH}
V_{IL}	Low-level input voltage	Recommended V_{IL}
I_{IH}	High-level input current	I_{IH}
I_{IL}	Low-level input current	I_{IL}

(1) From TJA1050 Product Specification, Philips Semiconductors, 2002 May 16.

Equivalent Input and Output Schematic Diagrams

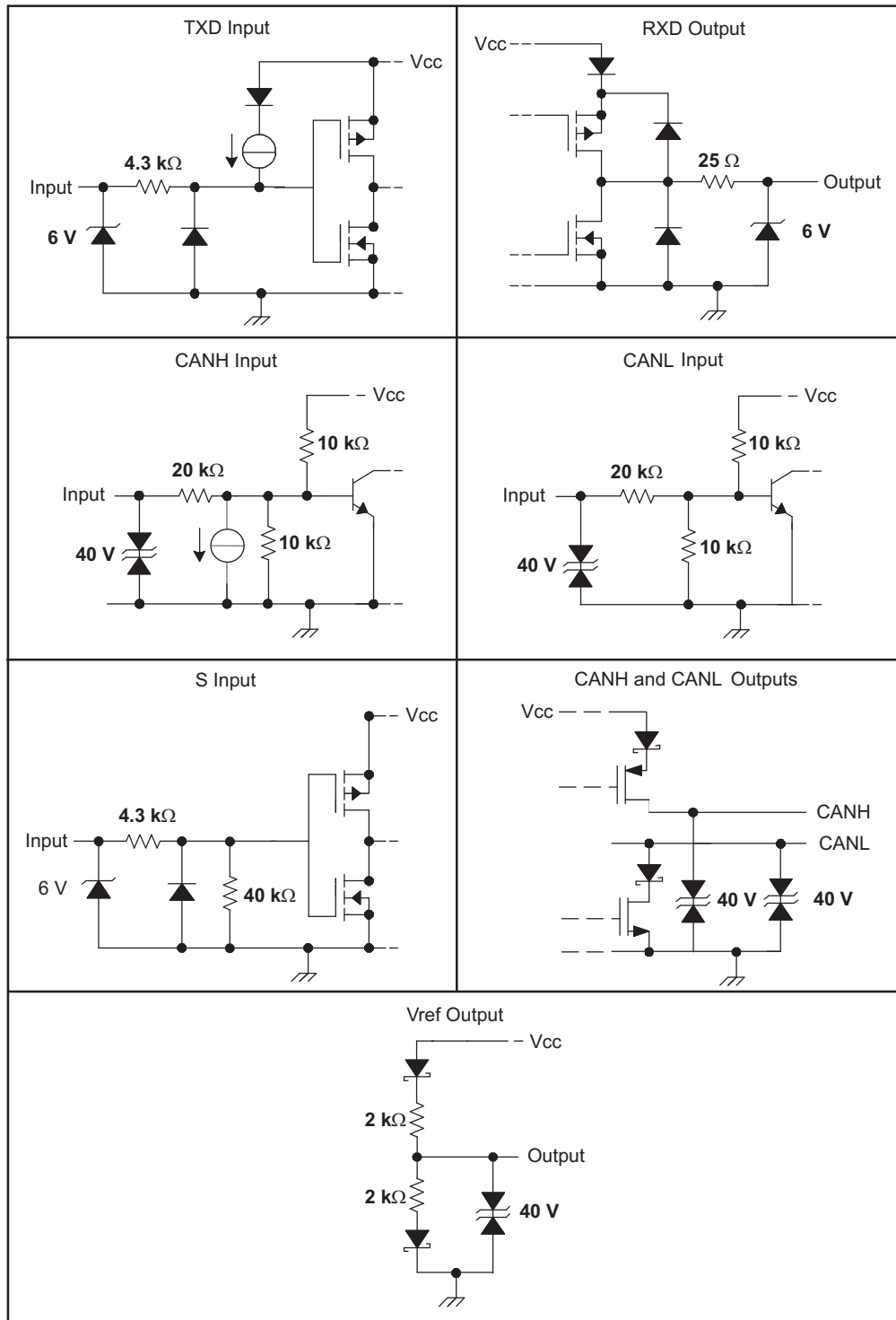

TYPICAL CHARACTERISTICS

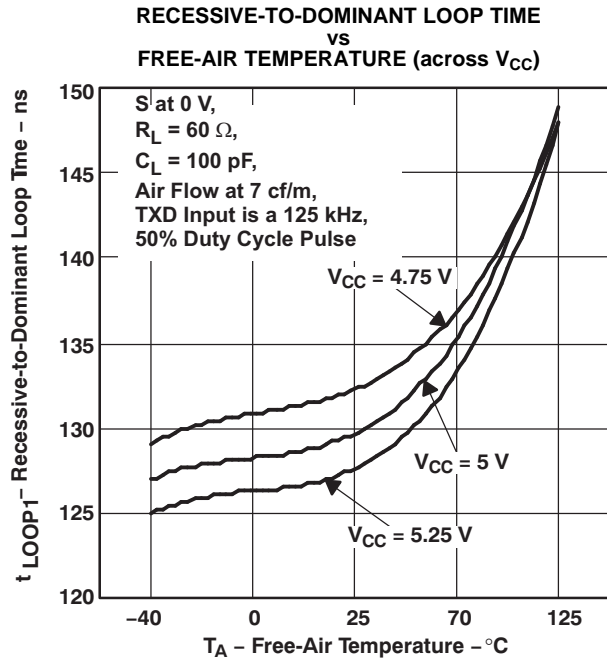

Figure 12.

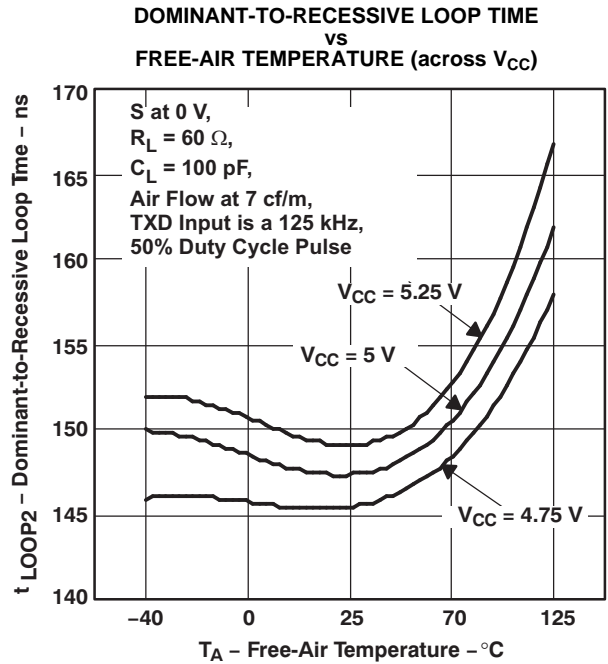

Figure 13.

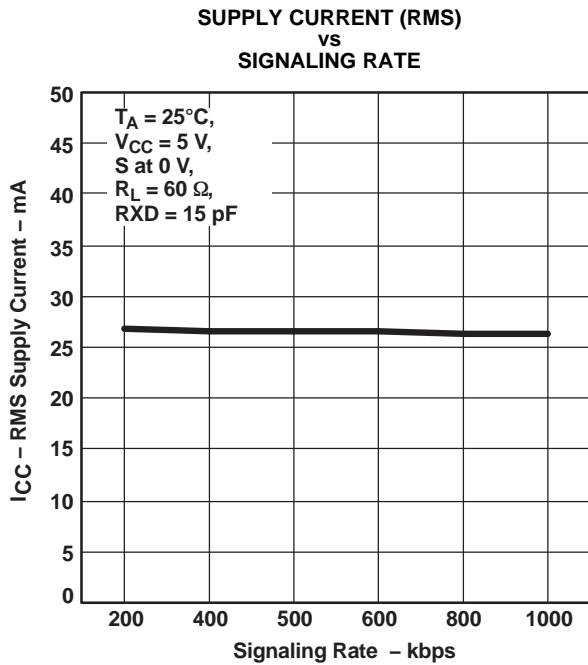

Figure 14.

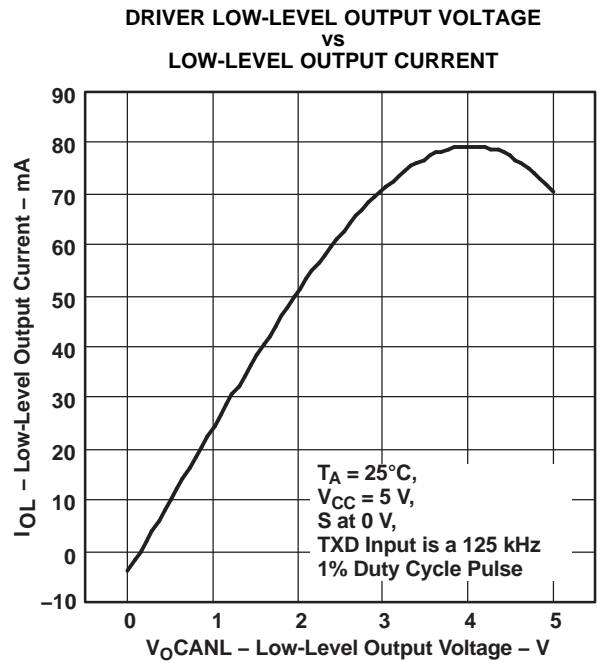

Figure 15.

TYPICAL CHARACTERISTICS (continued)

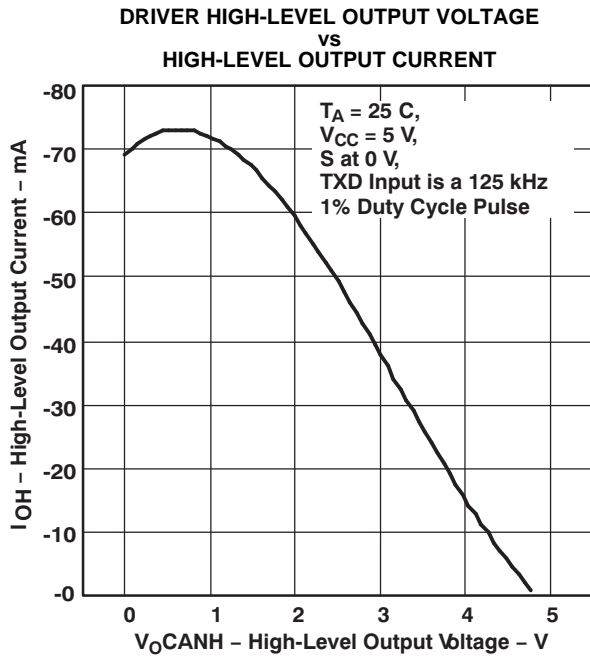

Figure 16.

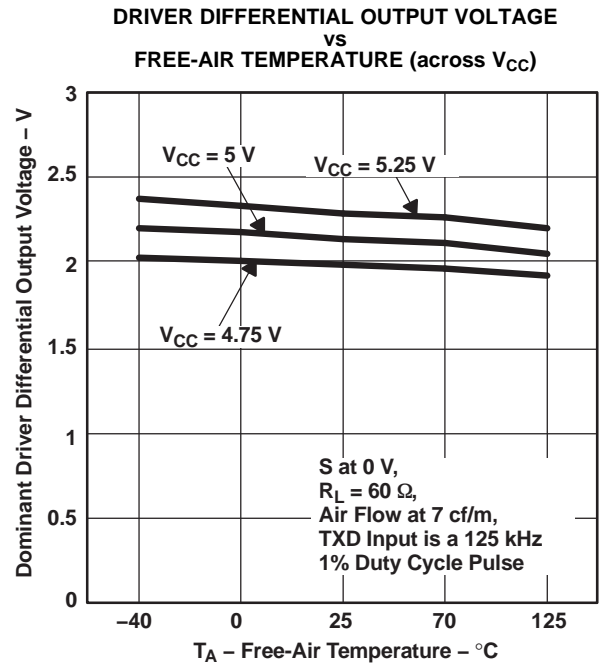

Figure 17.

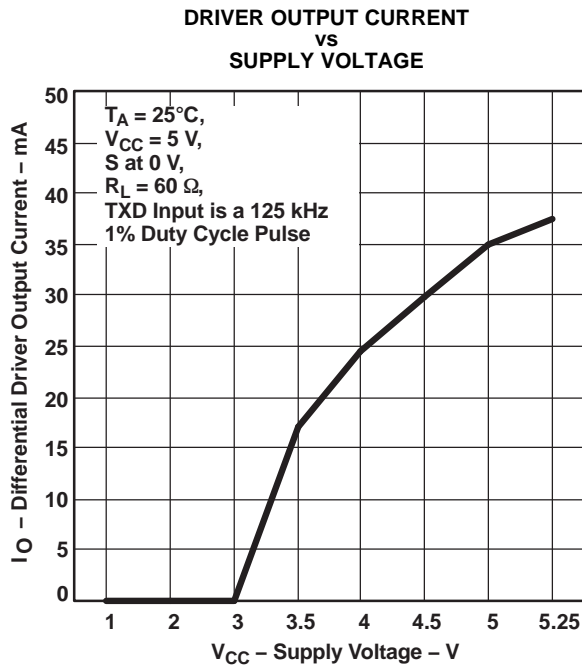

Figure 18.

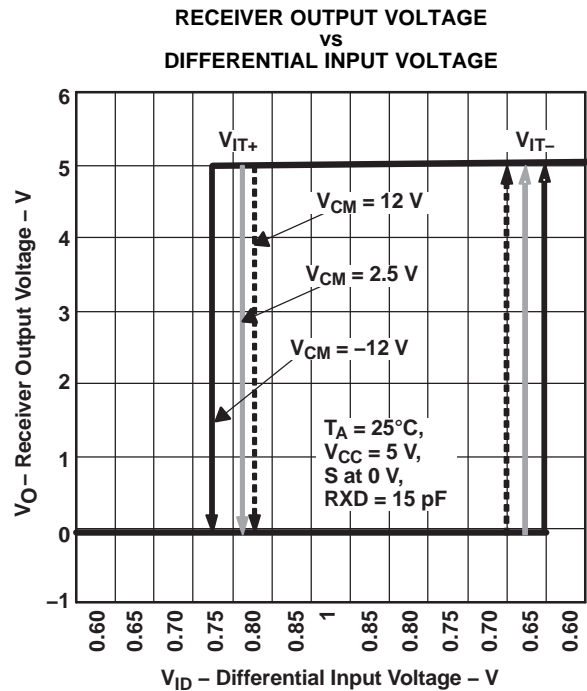

Figure 19.

TYPICAL CHARACTERISTICS (continued)

TYPICAL ELECTROMAGNETIC EMISSIONS
UP TO 50 MHz (Peak Amplitude)

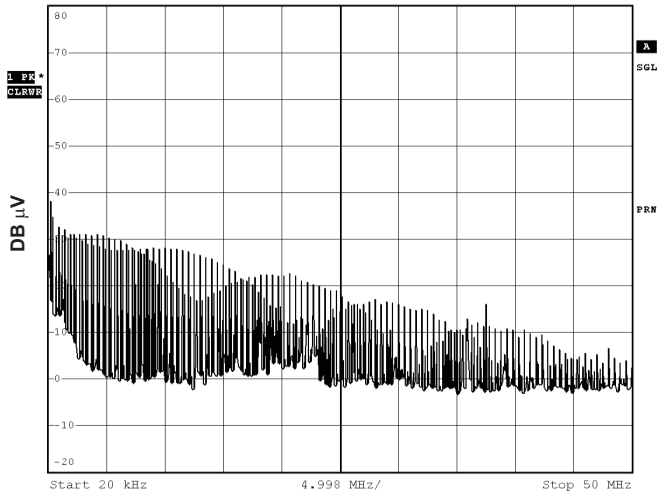

Figure 20. Frequency Spectrum of Common-Mode Emissions

TYPICAL ELECTROMAGNETIC
IMMUNITY PERFORMANCE

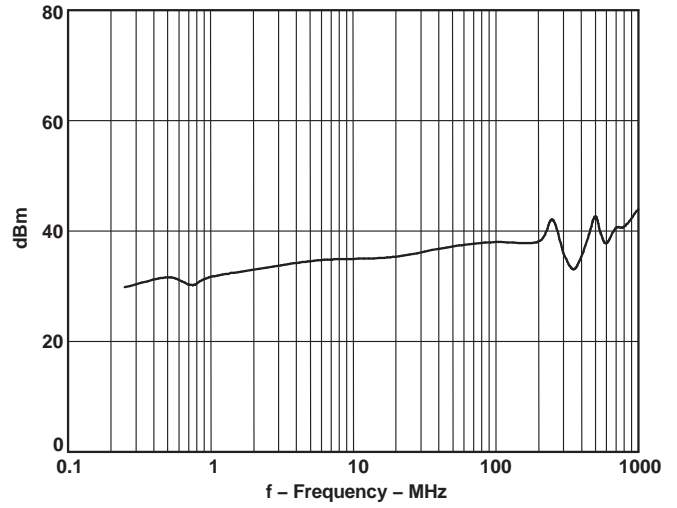

Figure 21. Direct Power Injection (DPI) Response vs Frequency

APPLICATION INFORMATION

THERMAL SHUTDOWN

The SN65HVD1050 has a thermal shutdown feature that turns off the driver outputs when the junction temperature nears 190°C. This shutdown prevents catastrophic failure from bus shorts, but does not protect the circuit from possible damage. The user should strive to maintain recommended operating conditions and not exceed absolute-maximum ratings at all times. If an SN65HVD1050 is subjected to many, or long-duration faults that can put the device into thermal shutdown, it should be replaced.

PACKAGING INFORMATION

Orderable Device	Status ⁽¹⁾	Package Type	Package Drawing	Pins	Package Qty	Eco Plan ⁽²⁾	Lead/Ball Finish	MSL Peak Temp ⁽³⁾
SN65HVD1050D	ACTIVE	SOIC	D	8	75	Green (RoHS & no Sb/Br)	CU NIPDAU	Level-1-260C-UNLIM
SN65HVD1050DG4	ACTIVE	SOIC	D	8	75	Green (RoHS & no Sb/Br)	CU NIPDAU	Level-1-260C-UNLIM
SN65HVD1050DR	ACTIVE	SOIC	D	8	2500	Green (RoHS & no Sb/Br)	CU NIPDAU	Level-1-260C-UNLIM
SN65HVD1050DRG4	ACTIVE	SOIC	D	8	2500	Green (RoHS & no Sb/Br)	CU NIPDAU	Level-1-260C-UNLIM

⁽¹⁾ The marketing status values are defined as follows:

ACTIVE: Product device recommended for new designs.

LIFEBUY: TI has announced that the device will be discontinued, and a lifetime-buy period is in effect.

NRND: Not recommended for new designs. Device is in production to support existing customers, but TI does not recommend using this part in a new design.

PREVIEW: Device has been announced but is not in production. Samples may or may not be available.

OBSOLETE: TI has discontinued the production of the device.

⁽²⁾ Eco Plan - The planned eco-friendly classification: Pb-Free (RoHS), Pb-Free (RoHS Exempt), or Green (RoHS & no Sb/Br) - please check <http://www.ti.com/productcontent> for the latest availability information and additional product content details.

TBD: The Pb-Free/Green conversion plan has not been defined.

Pb-Free (RoHS): TI's terms "Lead-Free" or "Pb-Free" mean semiconductor products that are compatible with the current RoHS requirements for all 6 substances, including the requirement that lead not exceed 0.1% by weight in homogeneous materials. Where designed to be soldered at high temperatures, TI Pb-Free products are suitable for use in specified lead-free processes.

Pb-Free (RoHS Exempt): This component has a RoHS exemption for either 1) lead-based flip-chip solder bumps used between the die and package, or 2) lead-based die adhesive used between the die and leadframe. The component is otherwise considered Pb-Free (RoHS compatible) as defined above.

Green (RoHS & no Sb/Br): TI defines "Green" to mean Pb-Free (RoHS compatible), and free of Bromine (Br) and Antimony (Sb) based flame retardants (Br or Sb do not exceed 0.1% by weight in homogeneous material)

⁽³⁾ MSL, Peak Temp. -- The Moisture Sensitivity Level rating according to the JEDEC industry standard classifications, and peak solder temperature.

Important Information and Disclaimer:The information provided on this page represents TI's knowledge and belief as of the date that it is provided. TI bases its knowledge and belief on information provided by third parties, and makes no representation or warranty as to the accuracy of such information. Efforts are underway to better integrate information from third parties. TI has taken and continues to take reasonable steps to provide representative and accurate information but may not have conducted destructive testing or chemical analysis on incoming materials and chemicals. TI and TI suppliers consider certain information to be proprietary, and thus CAS numbers and other limited information may not be available for release.

In no event shall TI's liability arising out of such information exceed the total purchase price of the TI part(s) at issue in this document sold by TI to Customer on an annual basis.

TAPE AND REEL INFORMATION



QUADRANT ASSIGNMENTS FOR PIN 1 ORIENTATION IN TAPE



*All dimensions are nominal

Device	Package Type	Package Drawing	Pins	SPQ	Reel Diameter (mm)	Reel Width W1 (mm)	A0 (mm)	B0 (mm)	K0 (mm)	P1 (mm)	W (mm)	Pin1 Quadrant
SN65HVD1050DR	SOIC	D	8	2500	330.0	12.4	6.4	5.2	2.1	8.0	12.0	Q1

TAPE AND REEL BOX DIMENSIONS



*All dimensions are nominal

Device	Package Type	Package Drawing	Pins	SPQ	Length (mm)	Width (mm)	Height (mm)
SN65HVD1050DR	SOIC	D	8	2500	346.0	346.0	29.0

D (R-PDSO-G8)

PLASTIC SMALL-OUTLINE PACKAGE

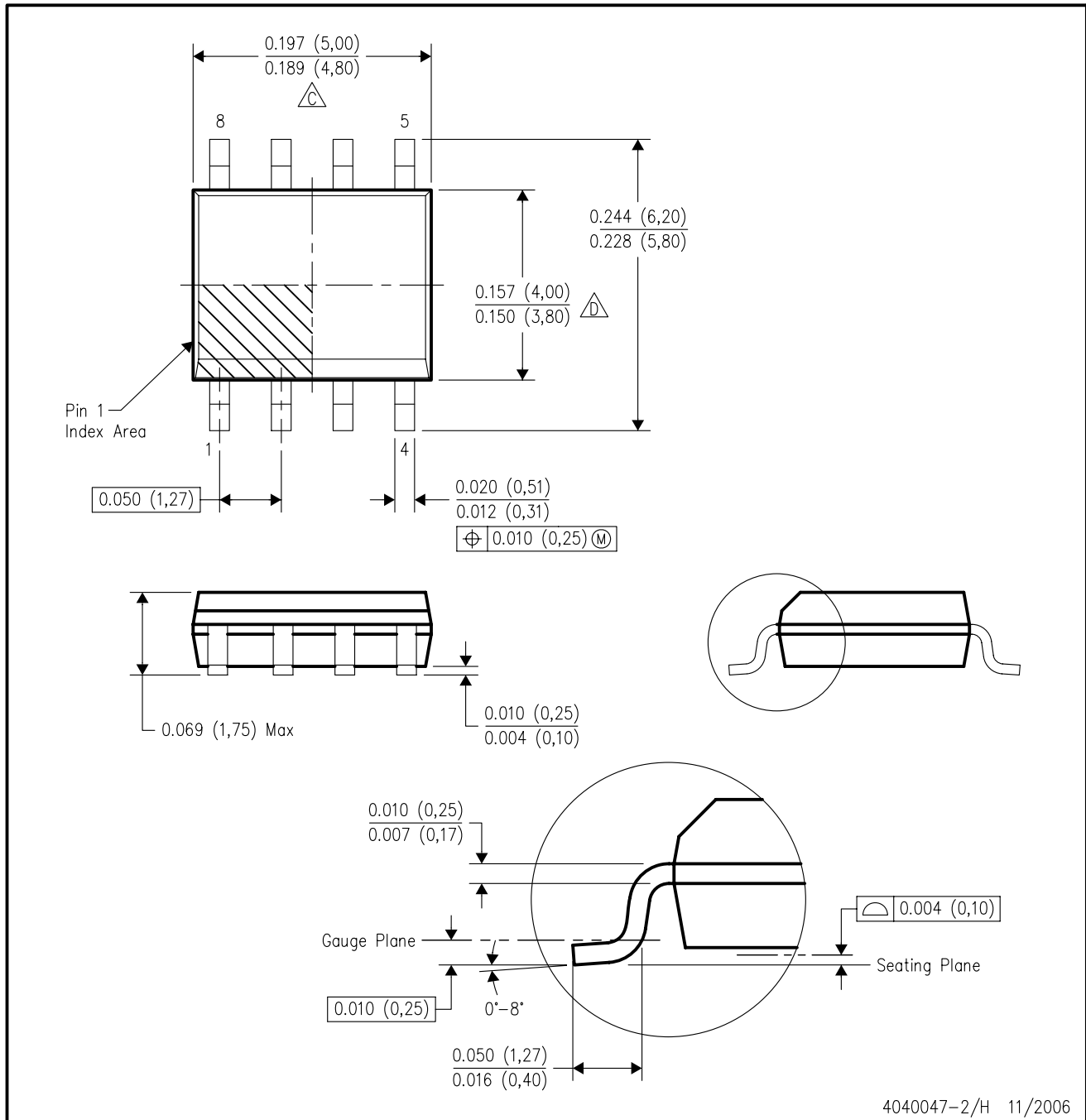

- NOTES:
- A. All linear dimensions are in inches (millimeters).
 - B. This drawing is subject to change without notice.
 - C. Body length does not include mold flash, protrusions, or gate burrs. Mold flash, protrusions, or gate burrs shall not exceed .006 (0,15) per end.
 - D. Body width does not include interlead flash. Interlead flash shall not exceed .017 (0,43) per side.
 - E. Reference JEDEC MS-012 variation AA.

IMPORTANT NOTICE

Texas Instruments Incorporated and its subsidiaries (TI) reserve the right to make corrections, modifications, enhancements, improvements, and other changes to its products and services at any time and to discontinue any product or service without notice. Customers should obtain the latest relevant information before placing orders and should verify that such information is current and complete. All products are sold subject to TI's terms and conditions of sale supplied at the time of order acknowledgment.

TI warrants performance of its hardware products to the specifications applicable at the time of sale in accordance with TI's standard warranty. Testing and other quality control techniques are used to the extent TI deems necessary to support this warranty. Except where mandated by government requirements, testing of all parameters of each product is not necessarily performed.

TI assumes no liability for applications assistance or customer product design. Customers are responsible for their products and applications using TI components. To minimize the risks associated with customer products and applications, customers should provide adequate design and operating safeguards.

TI does not warrant or represent that any license, either express or implied, is granted under any TI patent right, copyright, mask work right, or other TI intellectual property right relating to any combination, machine, or process in which TI products or services are used. Information published by TI regarding third-party products or services does not constitute a license from TI to use such products or services or a warranty or endorsement thereof. Use of such information may require a license from a third party under the patents or other intellectual property of the third party, or a license from TI under the patents or other intellectual property of TI.

Reproduction of TI information in TI data books or data sheets is permissible only if reproduction is without alteration and is accompanied by all associated warranties, conditions, limitations, and notices. Reproduction of this information with alteration is an unfair and deceptive business practice. TI is not responsible or liable for such altered documentation. Information of third parties may be subject to additional restrictions.

Resale of TI products or services with statements different from or beyond the parameters stated by TI for that product or service voids all express and any implied warranties for the associated TI product or service and is an unfair and deceptive business practice. TI is not responsible or liable for any such statements.

TI products are not authorized for use in safety-critical applications (such as life support) where a failure of the TI product would reasonably be expected to cause severe personal injury or death, unless officers of the parties have executed an agreement specifically governing such use. Buyers represent that they have all necessary expertise in the safety and regulatory ramifications of their applications, and acknowledge and agree that they are solely responsible for all legal, regulatory and safety-related requirements concerning their products and any use of TI products in such safety-critical applications, notwithstanding any applications-related information or support that may be provided by TI. Further, Buyers must fully indemnify TI and its representatives against any damages arising out of the use of TI products in such safety-critical applications.

TI products are neither designed nor intended for use in military/aerospace applications or environments unless the TI products are specifically designated by TI as military-grade or "enhanced plastic." Only products designated by TI as military-grade meet military specifications. Buyers acknowledge and agree that any such use of TI products which TI has not designated as military-grade is solely at the Buyer's risk, and that they are solely responsible for compliance with all legal and regulatory requirements in connection with such use.

TI products are neither designed nor intended for use in automotive applications or environments unless the specific TI products are designated by TI as compliant with ISO/TS 16949 requirements. Buyers acknowledge and agree that, if they use any non-designated products in automotive applications, TI will not be responsible for any failure to meet such requirements.

Following are URLs where you can obtain information on other Texas Instruments products and application solutions:

Products

Amplifiers	amplifier.ti.com
Data Converters	dataconverter.ti.com
DSP	dsp.ti.com
Clocks and Timers	www.ti.com/clocks
Interface	interface.ti.com
Logic	logic.ti.com
Power Mgmt	power.ti.com
Microcontrollers	microcontroller.ti.com
RFID	www.ti-rfid.com
RF/IF and ZigBee® Solutions	www.ti.com/lprf

Applications

Audio	www.ti.com/audio
Automotive	www.ti.com/automotive
Broadband	www.ti.com/broadband
Digital Control	www.ti.com/digitalcontrol
Medical	www.ti.com/medical
Military	www.ti.com/military
Optical Networking	www.ti.com/opticalnetwork
Security	www.ti.com/security
Telephony	www.ti.com/telephony
Video & Imaging	www.ti.com/video
Wireless	www.ti.com/wireless

Mailing Address: Texas Instruments, Post Office Box 655303, Dallas, Texas 75265
Copyright © 2008, Texas Instruments Incorporated