

SN55HVD75-EP 3.3-V Supply RS-485 With IEC ESD Protection

1 Features

- Bus I/O Protection
 - $> \pm 15$ kV HBM Protection
 - $> \pm 12$ kV IEC 61000-4-2 Contact Discharge
 - $> \pm 4$ kV IEC 61000-4-4 Fast Transient Burst
- Extended Industrial Temperature Range
–55°C to 125°C
- Large Receiver Hysteresis (80 mV) for Noise Rejection
- Low Unit-Loading Allows Over 200 Connected Nodes
- Low Power Consumption
 - Low Standby Supply Current: $< 2 \mu\text{A}$
 - $I_{\text{CC}} < 1$ mA Quiescent During Operation
- 5-V Tolerant Logic Inputs Compatible With 3.3-V or 5-V Controllers
- Signaling Rate Options Optimized for:
250 kbps, 20 Mbps, 50 Mbps
- Available in a Small VSON Package
- **Supports Defense, Aerospace, and Medical Applications:**
 - Controlled Baseline
 - One Assembly/Test Site
 - One Fabrication Site
 - Available in Extended (–55°C to 125°C) Temperature Range
 - Extended Product Life Cycle
 - Extended Product-Change Notification
 - Product Traceability

2 Applications

- Factory Automation
- Telecommunications Infrastructure
- Motion Control

3 Description

These devices have robust 3.3-V drivers and receivers in a small package for demanding industrial applications. The bus pins are robust to ESD events with high levels of protection to human-body model and IEC contact discharge specifications.

Each of these devices combines a differential driver and a differential receiver which operate from a single 3.3-V power supply. The driver differential outputs and the receiver differential inputs are connected internally to form a bus port suitable for half-duplex (two-wire bus) communication. These devices feature a wide common-mode voltage range making the devices suitable for multi-point applications over long cable runs. These devices are characterized from –55°C to 125°C.

Device Information⁽¹⁾

PART NUMBER	PACKAGE	BODY SIZE (NOM)
SN55HVD75-EP	VSON (8)	3.00 mm x 3.00 mm

(1) For all available packages, see the orderable addendum at the end of the data sheet.

Typical Application Diagram

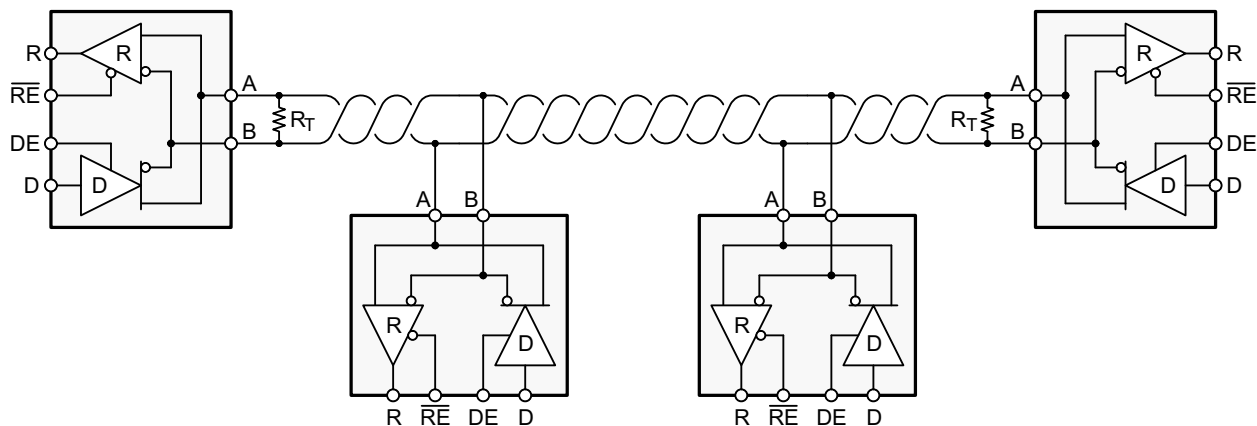

Table of Contents

1 Features	1	8.2 Functional Block Diagram	12
2 Applications	1	8.3 Feature Description	12
3 Description	1	8.4 Device Functional Modes	12
4 Revision History	2	9 Application and Implementation	14
5 Pin Configuration and Functions	3	9.1 Application Information	14
6 Specifications	3	9.2 Typical Application	15
6.1 Absolute Maximum Ratings	3	10 Power Supply Recommendations	22
6.2 ESD Ratings	3	11 Layout	22
6.3 Recommended Operating Conditions	4	11.1 Layout Guidelines	22
6.4 Thermal Information	4	11.2 Layout Example	23
6.5 Electrical Characteristics	5	12 Device and Documentation Support	24
6.6 Switching Characteristics: 20 Mbps Device, Bit Time ≥50 ns	6	12.1 Device Support	24
6.7 Typical Characteristics	7	12.2 Community Resources	24
7 Parameter Measurement Information	8	12.3 Trademarks	24
8 Detailed Description	12	12.4 Electrostatic Discharge Caution	24
8.1 Overview	12	12.5 Glossary	24
		13 Mechanical, Packaging, and Orderable Information	24

4 Revision History

DATE	REVISION	NOTES
October 2015	*	Initial release.

5 Pin Configuration and Functions

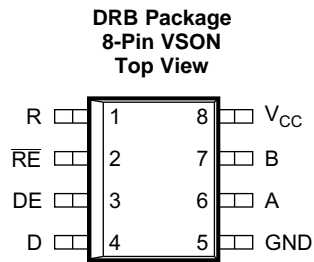

Pin Functions

PIN		TYPE	DESCRIPTION
NAME	NO.		
A	6	Bus I/O	Driver output or receiver input (complementary to B)
B	7	Bus I/O	Driver output or receiver input (complementary to A)
D	4	Digital input	Driver data input
DE	3	Digital input	Active-high driver enable
GND	5	Reference potential	Local device ground
R	1	Digital output	Receive data output
\overline{RE}	2	Digital input	Active-low receiver enable
V_{CC}	8	Supply	3-V to 3.6-V supply

6 Specifications

6.1 Absolute Maximum Ratings

over recommended operating range (unless otherwise specified) ⁽¹⁾

	MIN	MAX	UNIT
Supply voltage, V_{CC}	-0.5	5.5	V
Voltage at A or B inputs	-13	16.5	V
Input voltage at any logic pin	-0.3	5.7	V
Voltage input, transient pulse, A and B, through 100 Ω	-100	100	V
Receiver output current	-24	24	mA
Junction temperature, T_J		170	$^{\circ}\text{C}$
Storage temperature, T_{stg}	-65	150	$^{\circ}\text{C}$

(1) Stresses beyond those listed under *Absolute Maximum Ratings* may cause permanent damage to the device. These are stress ratings only and functional operation of the device at these or any other conditions beyond those indicated under *Recommended Operating Conditions* is not implied. Exposure to absolute-maximum-rated conditions for extended periods may affect device reliability.

6.2 ESD Ratings

			VALUE	UNIT	
$V_{(ESD)}$	Electrostatic discharge	Human body model (HBM), per ANSI/ESDA/JEDEC JS-001 ⁽¹⁾	All pins	± 8000	V
		Charged device model (CDM), per JEDEC specification JESD22-C101 ⁽²⁾	All pins	± 1500	
		JEDEC standard 22, test method A115 (machine model)	All pins	± 300	
		IEC 61000-4-2 ESD (air-gap discharge) ⁽³⁾	Pins 5 to 7	± 12000	
		IEC 61000-4-2 ESD (contact discharge)	Pins 5 to 7	± 12000	
		IEC 61000-4-4 EFT (fast transient or burst)	Pins 5 to 7	± 4000	
		IEC 60749-26 ESD HBM	Pins 5 to 7	± 15000	

(1) JEDEC document JEP155 states that 500-V HBM allows safe manufacturing with a standard ESD control process.

(2) JEDEC document JEP157 states that 250-V CDM allows safe manufacturing with a standard ESD control process.

(3) By inference from contact discharge results, see *Application and Implementation*.

6.3 Recommended Operating Conditions

		MIN	NOM	MAX	UNIT
V_{CC}	Supply voltage	3	3.3	3.6	V
V_I	Input voltage at any bus terminal (separately or common mode) ⁽¹⁾	-7		12	V
V_{IH}	High-level input voltage (driver, driver enable, and receiver enable inputs)	2		V_{CC}	V
V_{IL}	Low-level input voltage (driver, driver enable, and receiver enable inputs)	0		0.8	V
V_{ID}	Differential input voltage	-12		12	V
I_O	Output current, driver	-60		60	mA
I_O	Output current, receiver	-8		8	mA
R_L	Differential load resistance	54	60		Ω
C_L	Differential load capacitance		50		pF
$1/t_{UI}$	Signaling rate			20	Mbps
$T_A^{(2)}$	Operating free-air temperature (see Thermal Information)	-55		125	$^{\circ}\text{C}$
T_J	Junction temperature	-55		150	$^{\circ}\text{C}$

- (1) The algebraic convention, in which the least positive (most negative) limit is designated as minimum, is used in this data sheet.
- (2) Operation is specified for internal (junction) temperatures up to 150 $^{\circ}\text{C}$. Self-heating due to internal power dissipation should be considered for each application. Maximum junction temperature is internally limited by the thermal shutdown (TSD) circuit which disables the driver outputs when the junction temperature reaches 170 $^{\circ}\text{C}$.

6.4 Thermal Information

THERMAL METRIC ⁽¹⁾	SN55HVD75-EP		UNIT
	DRB (VSON)		
	8 PINS		
$R_{\theta JA}$	Junction-to-ambient thermal resistance	40.0	$^{\circ}\text{C}/\text{W}$
$R_{\theta JC(\text{top})}$	Junction-to-case (top) thermal resistance	49.6	$^{\circ}\text{C}/\text{W}$
$R_{\theta JC(\text{bot})}$	Junction-to-case (bottom) thermal resistance	3.9	$^{\circ}\text{C}/\text{W}$
$R_{\theta JB}$	Junction-to-board thermal resistance	15.5	$^{\circ}\text{C}/\text{W}$
Ψ_{JT}	Junction-to-top characterization parameter	0.6	$^{\circ}\text{C}/\text{W}$
Ψ_{JB}	Junction-to-board characterization parameter	15.7	$^{\circ}\text{C}/\text{W}$
T_{TSD}	Thermal shutdown junction temperature	—	$^{\circ}\text{C}$

- (1) For more information about traditional and new thermal metrics, see the *Semiconductor and IC Package Thermal Metrics* application report, [SPRA953](#).

6.5 Electrical Characteristics

over recommended operating range (unless otherwise specified)

PARAMETER		TEST CONDITIONS		MIN	TYP	MAX	UNIT	
V _{OD}	Driver differential output voltage magnitude	R _L = 60 Ω, 375 Ω on each output to -7 V to 12 V		See Figure 6	1.5	2	V	
		R _L = 54 Ω (RS-485)			1.5	2		
		R _L = 100 Ω (RS-422), T _J ≥ 0°C V _{CC} ≥ 3.2 V			2	2.5		
Δ V _{OD}	Change in magnitude of driver differential output voltage	R _L = 54 Ω, C _L = 50 pF		-50	0	50	mV	
V _{OC(SS)}	Steady-state common-mode output voltage	Center of two 27-Ω load resistors		See Figure 7	1	V _{CC} /2	3	V
ΔV _{OC}	Change in differential driver output common-mode voltage				-50	0	50	mV
V _{OC(PP)}	Peak-to-peak driver common-mode output voltage				200			
C _{OD}	Differential output capacitance				15		pF	
V _{IT+}	Positive-going receiver differential input voltage threshold			See ⁽¹⁾	-70	-20	mV	
V _{IT-}	Negative-going receiver differential input voltage threshold			-200	-150	See ⁽¹⁾	mV	
V _{HYS}	Receiver differential input voltage threshold hysteresis (V _{IT+} - V _{IT-})			50	80		mV	
V _{OH}	Receiver high-level output voltage	I _{OH} = -8 mA		2.4	V _{CC} - 0.3		V	
V _{OL}	Receiver low-level output voltage	I _{OL} = 8 mA			0.2	0.4	V	
I _I	Driver input, driver enable, and receiver enable input current			-2.75		2.75	μA	
I _{OZ}	Receiver output high-impedance current	V _O = 0 V or V _{CC} , \overline{RE} at V _{CC}		-1		1	μA	
I _{OS}	Driver short-circuit output current			-165		165	mA	
I _I	Bus input current (disabled driver)	V _{CC} = 3 to 3.6 V or V _{CC} = 0 V DE at 0 V		V _I = 12 V	75	150	μA	
				V _I = -7 V	-100	-40		
I _{CC}	Supply current (quiescent)	Driver and receiver enabled	DE = V _{CC} , \overline{RE} = GND No load		750	950	μA	
		Driver enabled, receiver disabled	DE = V _{CC} , \overline{RE} = V _{CC} No load		300	500		
		Driver disabled, receiver enabled	DE = GND, \overline{RE} = GND No load		600	800		
		Driver and receiver disabled	DE = GND, D = open \overline{RE} = V _{CC} , No load		0.1	2		
Supply current (dynamic)		See Typical Characteristics						

(1) Under any specific conditions, V_{IT+} is assured to be at least V_{HYS} higher than V_{IT-}.

6.6 Switching Characteristics: 20 Mbps Device, Bit Time ≥ 50 ns

over recommended operating conditions

PARAMETER		TEST CONDITIONS		MIN	TYP	MAX	UNIT
DRIVER							
t_r, t_f	Driver differential output rise or fall time	$R_L = 54 \Omega$ $C_L = 50 \text{ pF}$	See Figure 8	1	7	14	ns
t_{PHL}, t_{PLH}	Driver propagation delay			6	11	17	ns
$t_{SK(P)}$	Driver pulse skew, $ t_{PHL} - t_{PLH} $				0	2	ns
t_{PHZ}, t_{PLZ}	Driver disable time				12	50	ns
t_{PZH}, t_{PZL}	Driver enable time	Receiver enabled	See Figure 9 and Figure 10		10	20	ns
		Receiver disabled			3	7	μs
RECEIVER							
t_r, t_f	Receiver output rise or fall time	$C_L = 15 \text{ pF}$	See Figure 11		5	10	ns
t_{PHL}, t_{PLH}	Receiver propagation delay time				60	70	ns
$t_{SK(P)}$	Receiver pulse skew, $ t_{PHL} - t_{PLH} $				0	6	ns
t_{PLZ}, t_{PHZ}	Receiver disable time				15	30	ns
$t_{pZL(1)}, t_{pZH(1)}, t_{pZL(2)}, t_{pZH(2)}$	Receiver enable time	Driver enabled	See Figure 12		10	50	ns
		Driver disabled		See Figure 13		3	8

6.7 Typical Characteristics

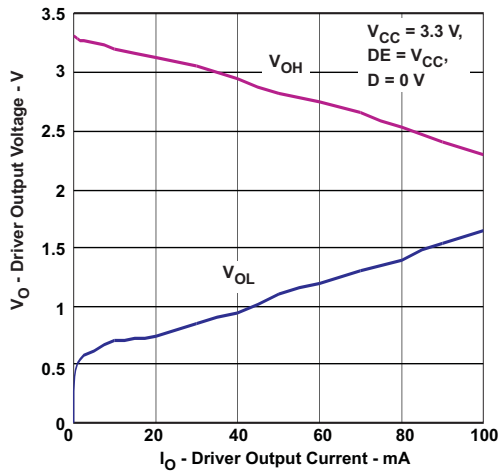

Figure 1. Driver Output Voltage vs Driver Output Current

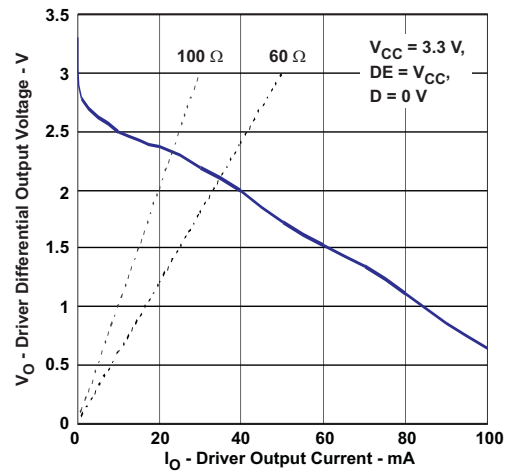

Figure 2. Driver Differential Output Voltage vs Driver Output Current

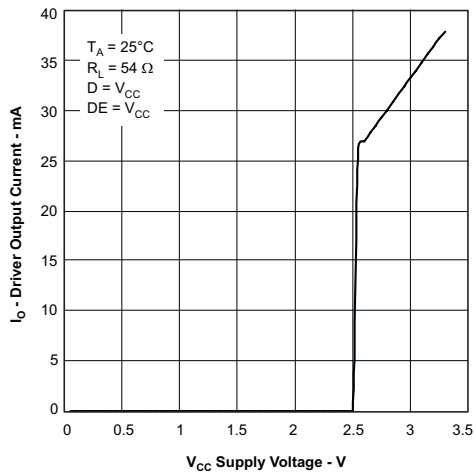

Figure 3. Driver Output Current vs Supply Voltage

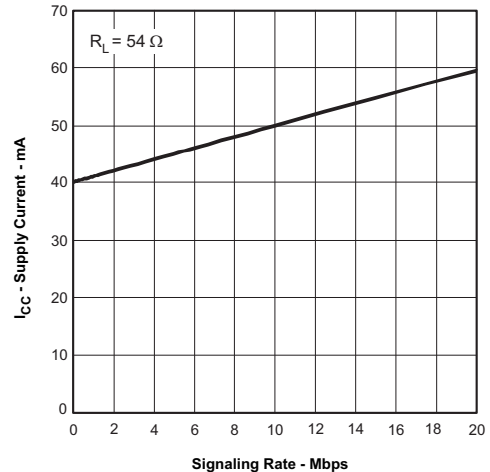

Figure 4. Supply Current vs Signal Rate

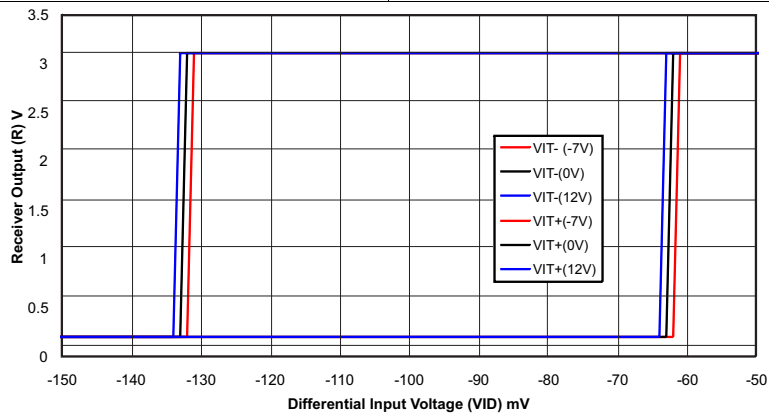
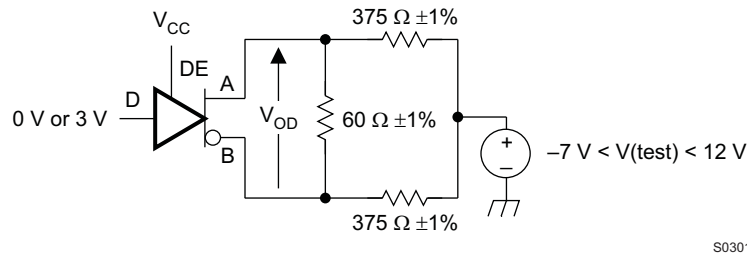

Figure 5. Receiver Output vs Input

7 Parameter Measurement Information

Input generator rate is 100 kbps, 50% duty cycle, rise or fall time is less than 6 ns, output impedance is 50 Ω .



S0301-01

Figure 6. Measurement of Driver Differential Output Voltage With Common-Mode Load

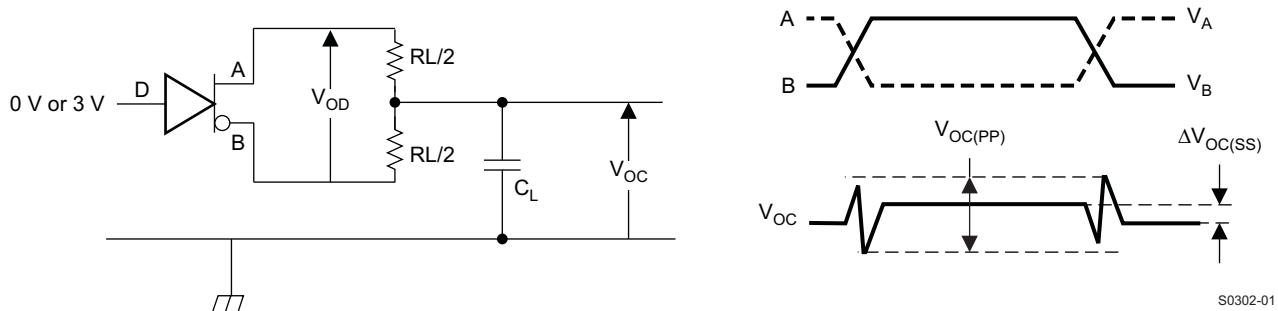

S0302-01

Figure 7. Measurement of Driver Differential and Common-Mode Output With RS-485 Load

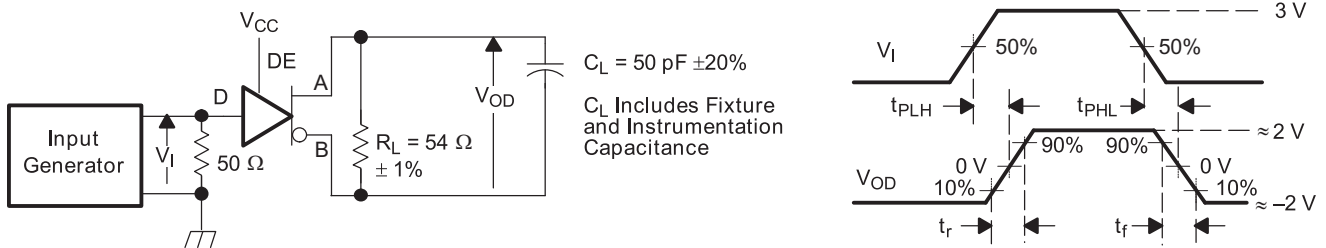
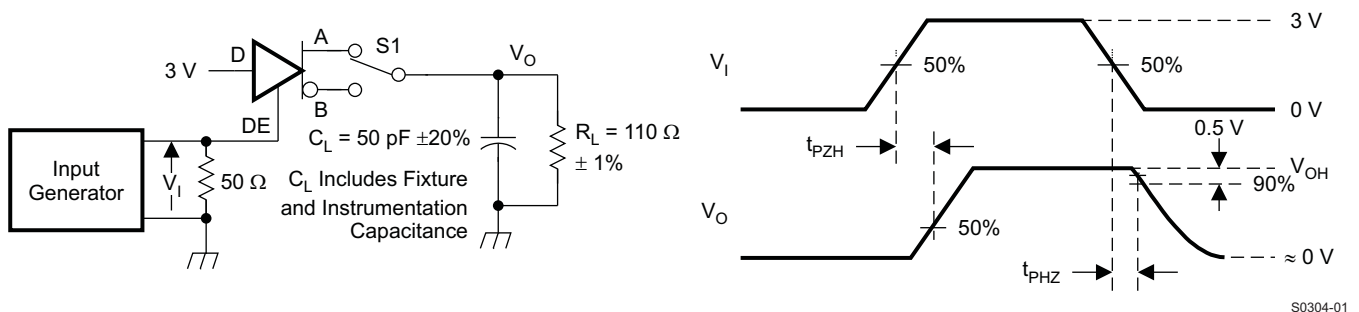

Figure 8. Measurement of Driver Differential Output Rise and Fall Times and Propagation Delays



S0304-01

D at 3 V to test non-inverting output, D at 0 V to test inverting output.

Figure 9. Measurement of Driver Enable and Disable Times With Active High Output and Pulldown Load

Parameter Measurement Information (continued)

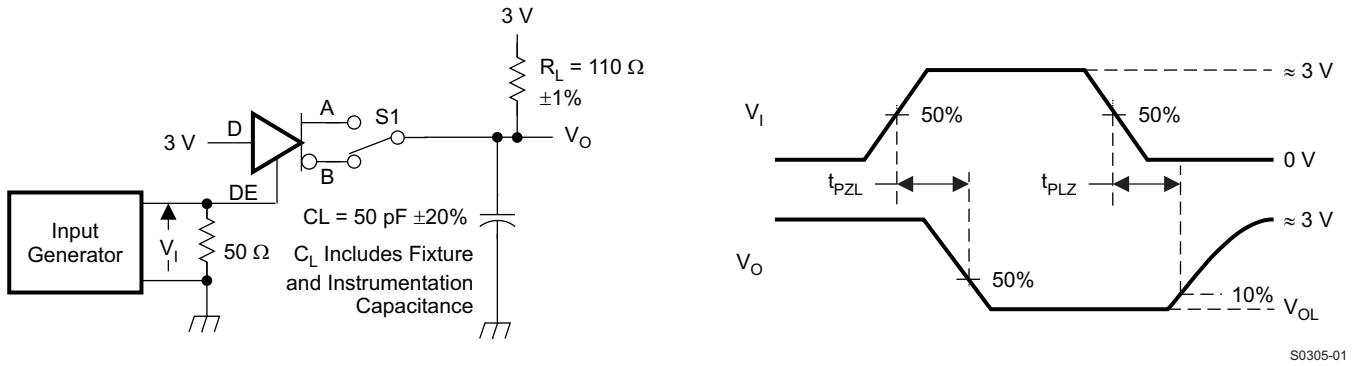

D at 0 V to test non-inverting output, D at 3 V to test inverting output.

Figure 10. Measurement of Driver Enable and Disable Times With Active Low Output and Pullup Load

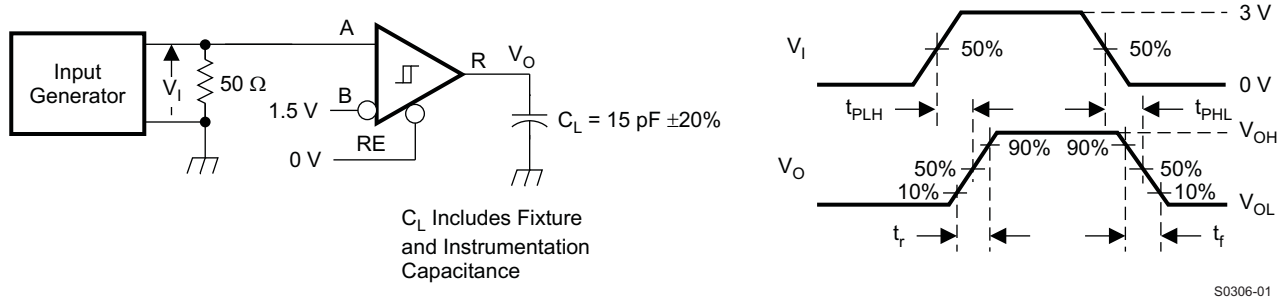
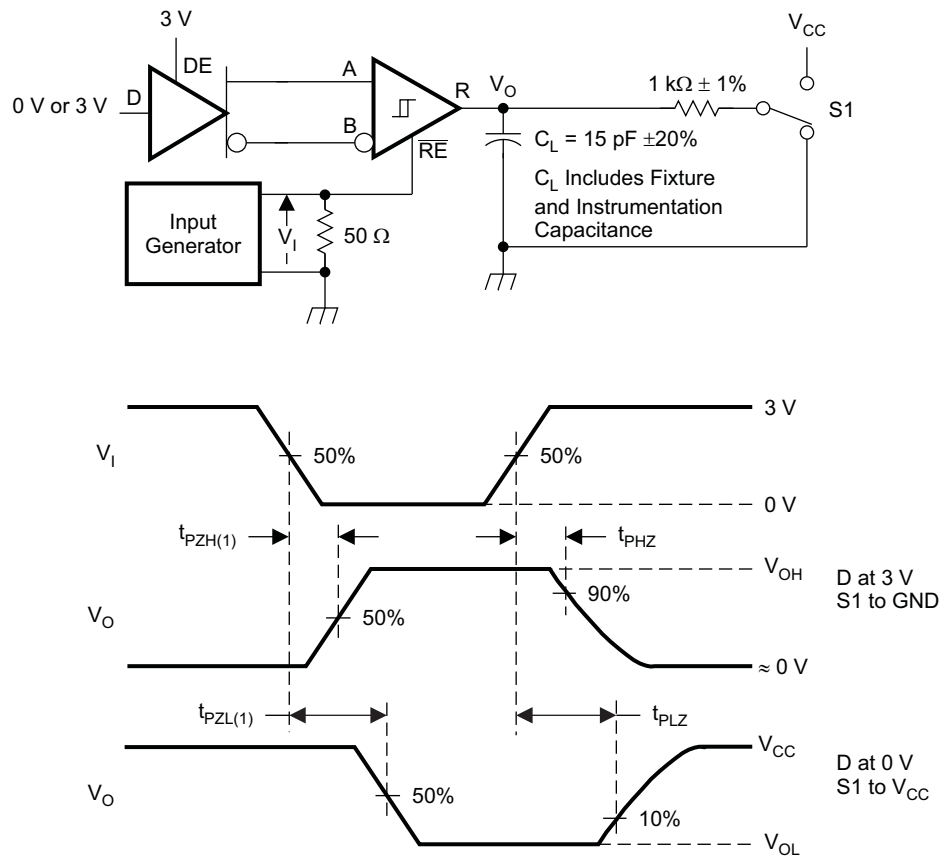

Figure 11. Measurement of Receiver Output Rise and Fall Times and Propagation Delays

Parameter Measurement Information (continued)



S0307-01

Figure 12. Measurement of Receiver Enable and Disable Times With Driver Enabled

Parameter Measurement Information (continued)

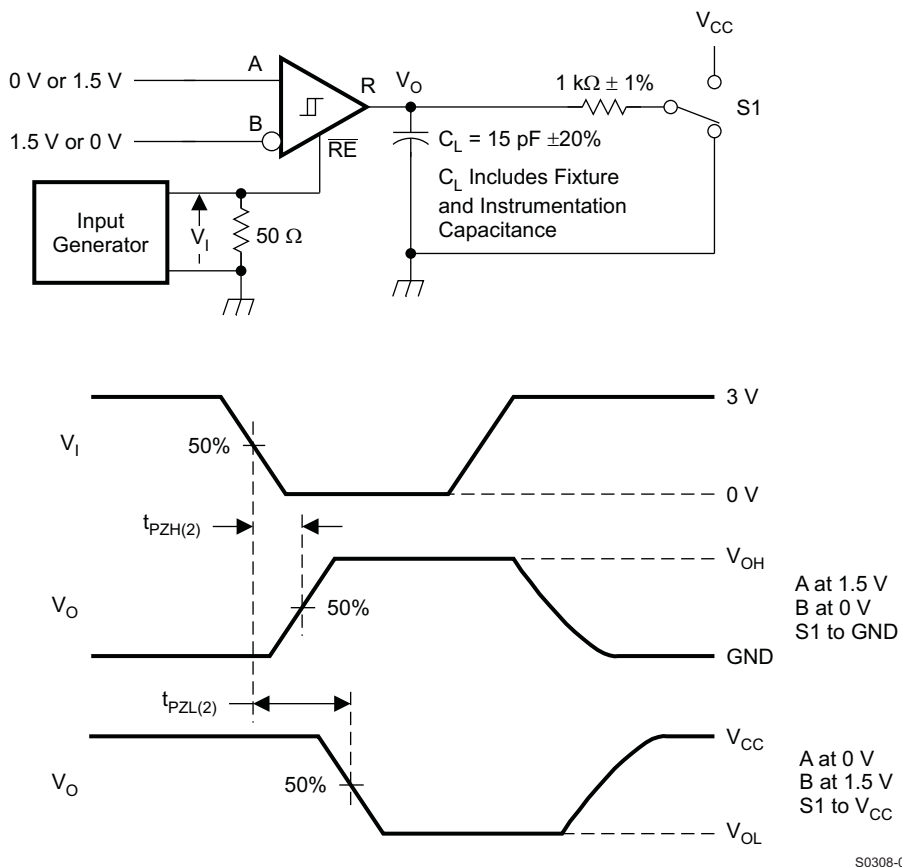

Figure 13. Measurement of Receiver Enable Times With Driver Disabled

8 Detailed Description

8.1 Overview

The SN55HVD75-EP is a low-power, half-duplex RS-485 transceiver available in a speed grade suitable for data transmission up to 20 Mbps.

This device has active-high driver enables and active-low receiver enables. A standby current of less than 2 μ A can be achieved by disabling both driver and receiver.

8.2 Functional Block Diagram

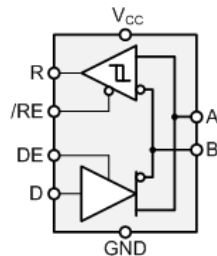

8.3 Feature Description

Internal ESD protection circuits protect the transceiver against electrostatic discharges (ESD) according to IEC 61000-4-2 of up to ± 12 kV, and against electrical fast transients (EFT) according to IEC 61000-4-4 of up to ± 4 kV.

The SN55HVD75-EP half-duplex family provides internal biasing of the receiver input thresholds in combination with large input threshold hysteresis. At a positive input threshold of $V_{IT+} = -20$ mV and an input hysteresis of $V_{HYS} = 50$ mV, the receiver output remains logic high under a bus-idle or bus-short condition even in the presence of 140-mV_{PP} differential noise without the need for external failsafe biasing resistors.

Device operation is specified over a wide ambient temperature range from -55°C to 125°C .

8.4 Device Functional Modes

When the driver enable pin, DE, is logic high, the differential outputs A and B follow the logic states at data input D. A logic high at D causes A to turn high and B to turn low. In this case the differential output voltage defined as $V_{OD} = V_A - V_B$ is positive. When D is low, the output states reverse, B turns high, A becomes low, and V_{OD} is negative.

When DE is low, both outputs turn high-impedance. In this condition the logic state at D is irrelevant. The DE pin has an internal pulldown resistor to ground; thus, when left open, the driver is disabled (high-impedance) by default. The D pin has an internal pullup resistor to V_{CC} ; thus, when left open while the driver is enabled, output A turns high and B turns low.

Table 1. Driver Function Table

INPUT	ENABLE	OUTPUTS		DESCRIPTION
		A	B	
H	H	H	L	Actively drive bus high
L	H	L	H	Actively drive bus low
X	L	Z	Z	Driver disabled
X	OPEN	Z	Z	Driver disabled by default
OPEN	H	H	L	Actively drive bus high by default

When the receiver enable pin, \overline{RE} , is logic low, the receiver is enabled. When the differential input voltage defined as $V_{ID} = V_A - V_B$ is positive and higher than the positive input threshold, V_{IT+} , the receiver output, R, turns high. When V_{ID} is negative and lower than the negative input threshold, V_{IT-} , the receiver output turns low. If V_{ID} is between V_{IT+} and V_{IT-} , the output is indeterminate.

When \overline{RE} is logic high or left open, the receiver output is high-impedance and the magnitude and polarity of V_{ID} are irrelevant. Internal biasing of the receiver inputs causes the output to go failsafe-high when the transceiver is disconnected from the bus (open-circuit), the bus lines are shorted (short-circuit), or the bus is not actively driven (idle bus).

Table 2. Receiver Function Table

DIFFERENTIAL INPUT	ENABLE	OUTPUT	DESCRIPTION
$V_{ID} = V_A - V_B$	\overline{RE}	R	
$V_{IT+} < V_{ID}$	L	H	Receive valid bus high
$V_{IT-} < V_{ID} < V_{IT+}$	L	?	Indeterminate bus state
$V_{ID} < V_{IT-}$	L	L	Receive valid bus low
X	H	Z	Receiver disabled
X	OPEN	Z	Receiver disabled by default
Open-circuit bus	L	H	Failsafe high output
Short-circuit bus	L	H	Failsafe high output
Idle (terminated) bus	L	H	Failsafe high output

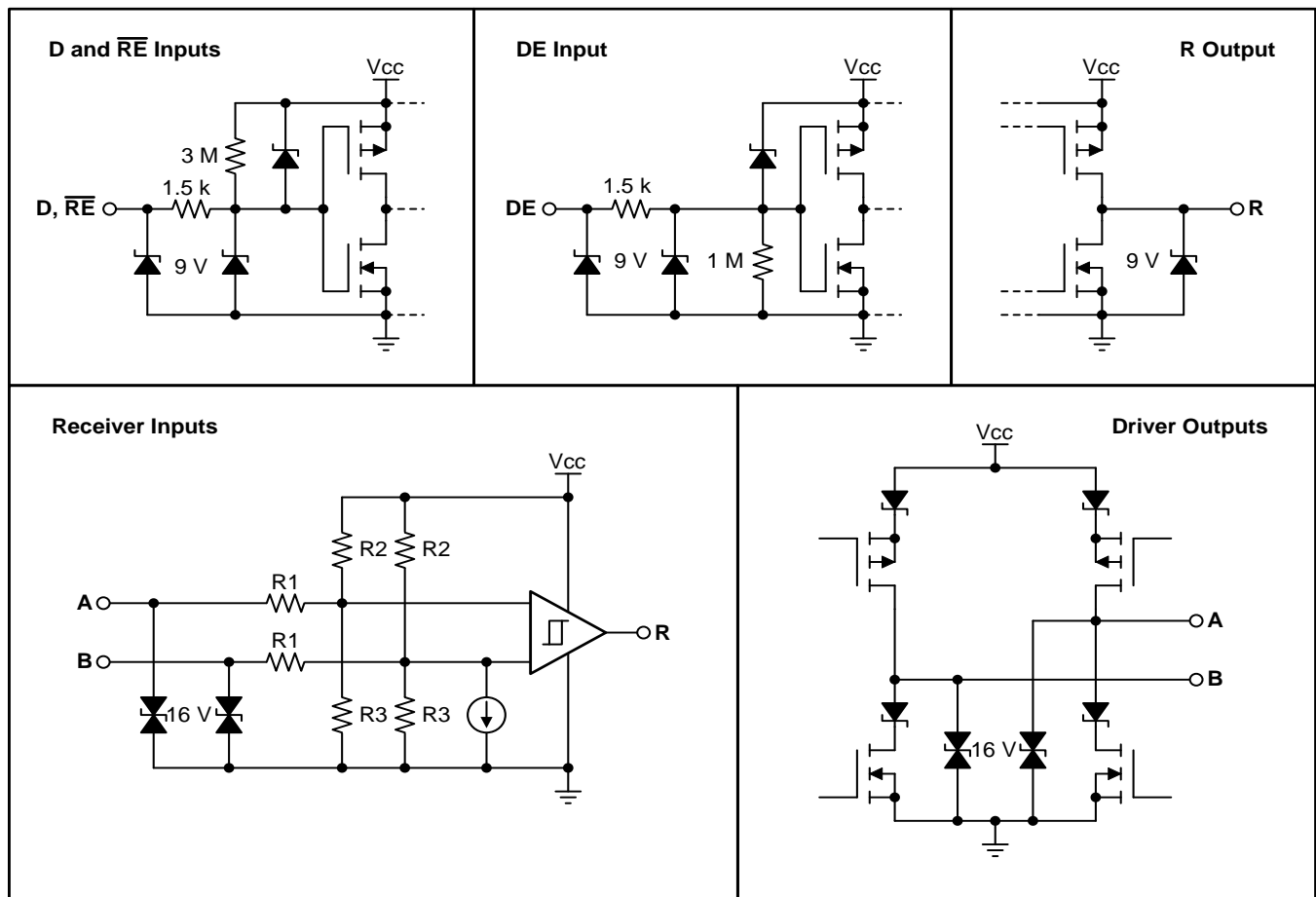

Figure 14. Equivalent Input and Output Circuit Diagrams

9 Application and Implementation

NOTE

Information in the following applications sections is not part of the TI component specification, and TI does not warrant its accuracy or completeness. TI's customers are responsible for determining suitability of components for their purposes. Customers should validate and test their design implementation to confirm system functionality.

9.1 Application Information

The SN55HVD75-EP is a half-duplex RS-485 transceiver commonly used for asynchronous data transmission. The driver and receiver enable pins allow for the configuration of different operating modes.

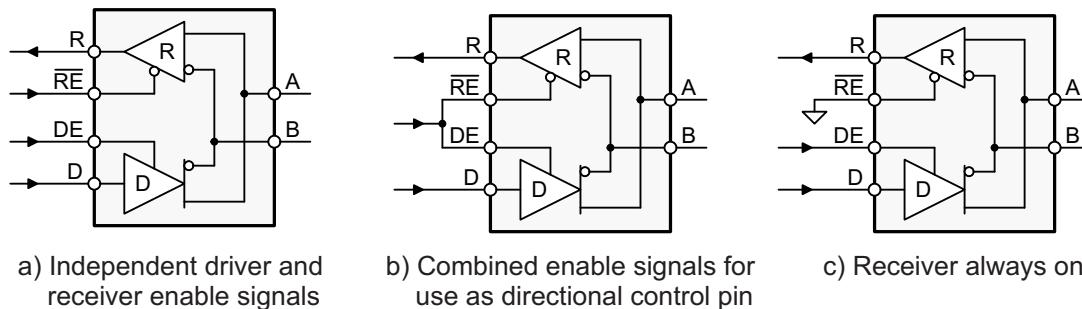

Figure 15. Transceiver Configurations

Using independent enable lines provides the most flexible control as it allows for the driver and the receiver to be turned on and off individually. While this configuration requires two control lines, it allows for selective listening into the bus traffic, whether the driver is transmitting data or not.

Combining the enable signals simplifies the interface to the controller by forming a single direction-control signal. In this configuration, the transceiver operates as a driver when the direction-control line is high, and as a receiver when the direction-control line is low.

Additionally, only one line is required when connecting the receiver-enable input to ground and controlling only the driver-enable input. In this configuration, a node not only receives the data from the bus, but also the data it sends and can verify that the correct data have been transmitted.

9.2 Typical Application

An RS-485 bus consists of multiple transceivers connected in parallel to a bus cable. To eliminate line reflections, each cable end is terminated with a termination resistor, R_T , whose value matches the characteristic impedance, Z_0 , of the cable. This method, known as parallel termination, allows for relatively high data rates over long cable lengths.

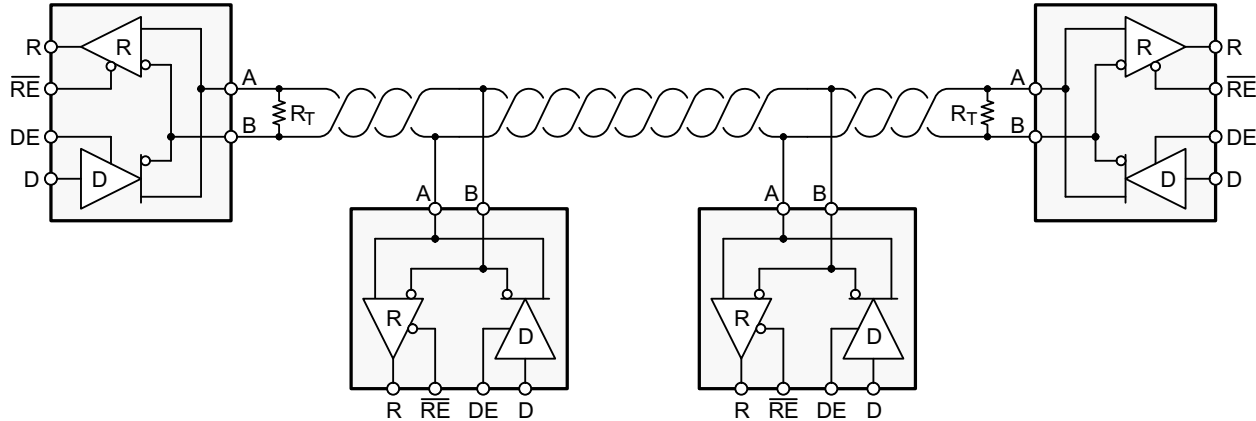

Figure 16. Typical RS-485 Network With SN55HVD75-EP Transceivers

Common cables used are unshielded twisted pair (UTP), such as low-cost CAT-5 cable with $Z_0 = 100 \Omega$, and RS-485 cable with $Z_0 = 120 \Omega$. Typical cable sizes are AWG 22 and AWG 24.

The maximum bus length is typically given as 4000 ft or 1200 m, and represents the length of an AWG 24 cable whose cable resistance approaches the value of the termination resistance, thus reducing the bus signal by half or 6 dB. Actual maximum usable cable length depends on the signaling rate, cable characteristics, and environmental conditions.

9.2.1 Design Requirements

RS-485 is a robust electrical standard suitable for long-distance networking that may be used in a wide range of applications with varying requirements, such as distance, data rate, and number of nodes.

9.2.1.1 Data Rate and Bus Length

There is an inverse relationship between data rate and bus length, meaning the higher the data rate, the shorter the cable length; and conversely, the lower the data rate, the longer the cable may be without introducing data errors. While most RS-485 systems use data rates between 10 kbps and 100 kbps, some applications require data rates up to 250 kbps at distances of 4000 feet and longer. Longer distances are possible by allowing for small signal jitter of up to 5 or 10%.

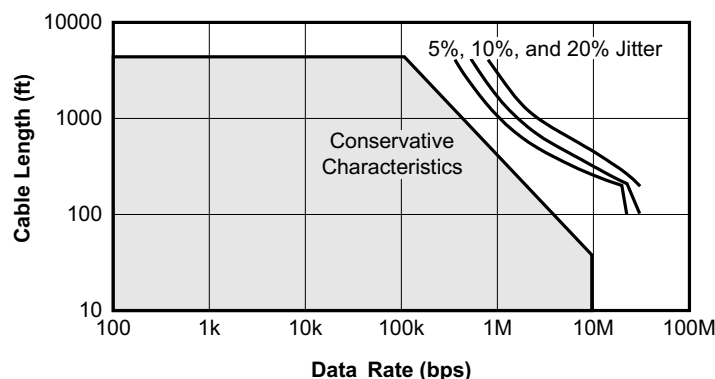

Figure 17. Cable Length vs Data Rate Characteristic

Typical Application (continued)

9.2.1.2 Stub Length

When connecting a node to the bus, the distance between the transceiver inputs and the cable trunk, known as the stub, should be as short as possible. Stubs present a non-terminated piece of bus line which can introduce reflections as the length of the stub increases. As a general guideline, the electrical length, or round-trip delay, of a stub should be less than one-tenth of the rise time of the driver, thus giving a maximum physical stub length as shown in [Equation 1](#).

$$L_{\text{stub}} \leq 0.1 \times t_r \times v \times c$$

where:

- t_r is the 10/90 rise time of the driver
 - c is the speed of light (3×10^8 m/s)
 - v is the signal velocity of the cable or trace as a factor of c
- (1)

Per [Equation 1](#), [Table 3](#) shows the maximum cable-stub lengths for the minimum driver output rise times of the SN55HVD75-EP half-duplex transceiver for a signal velocity of 78%.

Table 3. Maximum Stub Length

DEVICE	MINIMUM DRIVER OUTPUT RISE TIME (ns)	MAXIMUM STUB LENGTH	
		(m)	(ft)
SN55HVD75-EP	2	0.05	0.16

9.2.1.3 Bus Loading

The RS-485 standard specifies that a compliant driver must be able to drive 32 unit loads (UL), where 1 unit load represents a receiver input current of 1 mA at 12 V, or a load impedance of approximately 12 kΩ. Because the SN55HVD75-EP has a receiver input current of 150 μA at 12 V, they are 3/20 UL transceivers, and no more than 213 transceivers should be connected to the bus.

9.2.1.4 Receiver Failsafe

The differential receiver is failsafe to invalid bus states caused by:

- Open bus conditions such as a disconnected connector
- Shorted bus conditions such as cable damage shorting the twisted-pair together, or
- Idle bus conditions that occur when no driver on the bus is actively driving

In any of these cases, the differential receiver will output a failsafe logic high so that the output of the receiver is not indeterminate.

Receiver failsafe is accomplished by offsetting the receiver thresholds such that the input-indeterminate range does not include 0-V differential. To comply with the RS-422 and RS-485 standards, the receiver output must output a high when the differential input V_{ID} is more positive than 200 mV, and must output a low when V_{ID} is more negative than –200 mV. The receiver parameters which determine the failsafe performance are V_{IT+} , V_{IT-} , and V_{HYS} (the separation between V_{IT+} and V_{IT-}). As shown in [Electrical Characteristics](#), differential signals more negative than –200 mV will always cause a low receiver output, and differential signals more positive than 200 mV will always cause a high receiver output.

When the differential input signal is close to zero, it is still above the maximum V_{IT+} threshold of –20 mV, and the receiver output will be high. Only when the differential input is more than V_{HYS} below V_{IT+} will the receiver output transition to a low state. Therefore, the noise immunity of the receiver inputs during a bus fault condition includes the receiver hysteresis value, V_{HYS} , as well as the value of V_{IT+} .

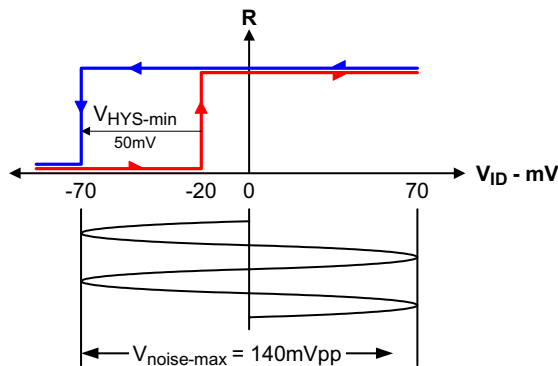

Figure 18. Noise Immunity

9.2.1.5 Transient Protection

The bus pins of the SN55HVD75-EP transceiver family possess on-chip ESD protection against ± 15 -kV human body model (HBM) and ± 12 -kV IEC 61000-4-2 contact discharge. The IEC-ESD test is far more severe than the HBM-ESD test. The 50% higher charge capacitance, C_S , and 78% lower discharge resistance, R_D , of the IEC-model produce significantly higher discharge currents than the HBM-model.

As stated in the IEC 61000-4-2 standard, contact discharge is the preferred test method; although IEC air-gap testing is less repeatable than contact testing, air discharge protection levels are inferred from the contact discharge test results.

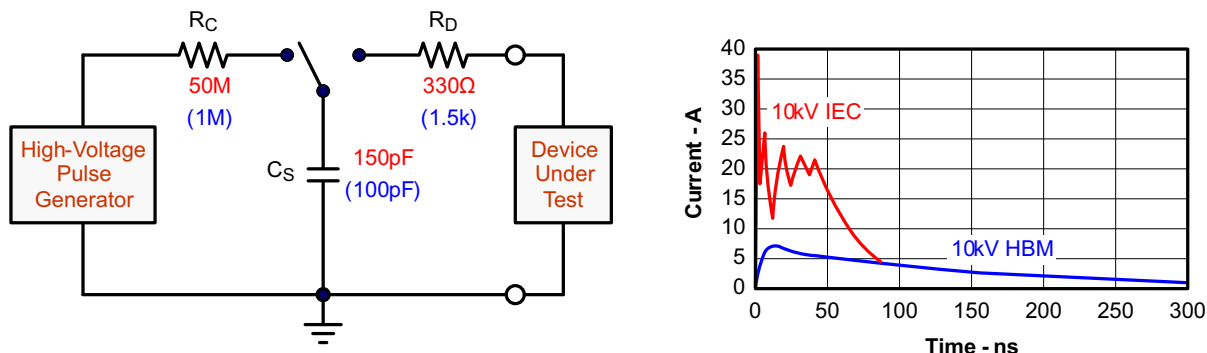

Figure 19. HBM and IEC-ESD Models and Currents in Comparison (HBM Values in Parenthesis)

The on-chip implementation of IEC ESD protection significantly increases the robustness of equipment. Common discharge events occur due to human contact with connectors and cables. Designers may choose to implement protection against longer duration transients, typically referred to as surge transients.

EFTs are generally caused by relay-contact bounce or the interruption of inductive loads. Surge transients often result from lightning strikes (direct strike or an indirect strike which induce voltages and currents), or the switching of power systems, including load changes and short circuit switching. These transients are often encountered in industrial environments, such as factory automation and power-grid systems.

Figure 20 compares the pulse-power of the EFT and surge transients with the power caused by an IEC ESD transient. The left-hand diagram shows the relative pulse-power for a 0.5-kV surge transient and 4-kV EFT transient, both of which dwarf the 10-kV ESD transient visible in the lower-left corner. 500-V surge transients are representative of events that may occur in factory environments in industrial and process automation.

The right-hand diagram shows the pulse-power of a 6-kV surge transient, relative to the same 0.5-kV surge transient. 6-kV surge transients are most likely to occur in power generation and power-grid systems.

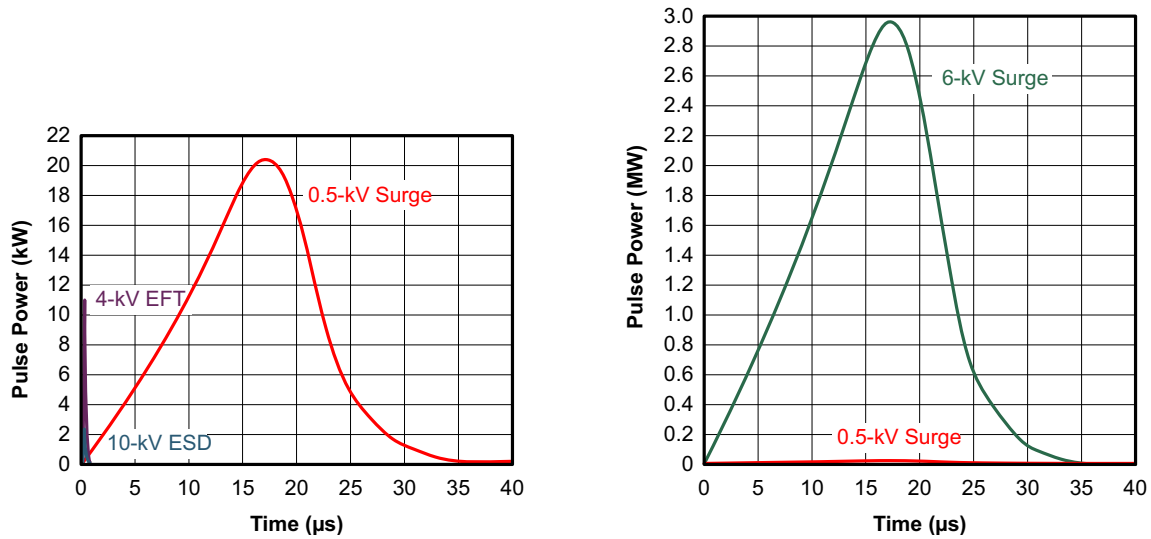

Figure 20. Power Comparison of ESD, EFT, and Surge Transients

In the case of surge transients, high-energy content is characterized by long pulse duration and slow decaying pulse power. The electrical energy of a transient that is dumped into the internal protection cells of a transceiver is converted into thermal energy which heats and destroys the protection cells, thus destroying the transceiver. Figure 21 shows the large differences in transient energies for single ESD, EFT, and surge transients, as well as for an EFT pulse train, commonly applied during compliance testing.

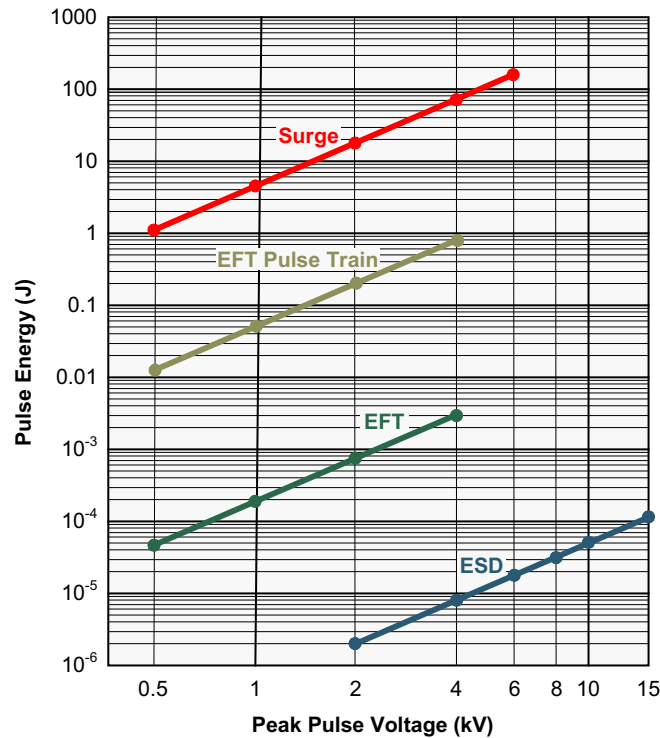

Figure 21. Comparison of Transient Energies

9.2.2 Detailed Design Procedure

9.2.2.1 External Transient Protection

To protect bus nodes against high-energy transients, the implementation of external transient protection devices is necessary. Figure 22 suggests two circuits that provide protection against light and heavy surge transients, in addition to ESD and EFT transients. Table 4 presents the associated bill of materials.

Table 4. Bill of Materials

DEVICE	FUNCTION	ORDER NUMBER	MANUFACTURER
XCVR	3.3-V, 250-kbps RS-485 transceiver	SN55HVD75DRBREP	TI
R1, R2	10-Ω, pulse-proof thick-film resistor	CRCW060310RJNEAHP	Vishay
TVS	Bidirectional 400-W transient suppressor	CDSOT23-SM712	Bourns
TBU1, TBU2	Bidirectional surge suppressor	TBU-CA-065-200-WH	Bourns
MOV1, MOV2	200-mA Transient blocking unit, 200-V, metal-oxide varistor	MOV-10D201K	Bourns

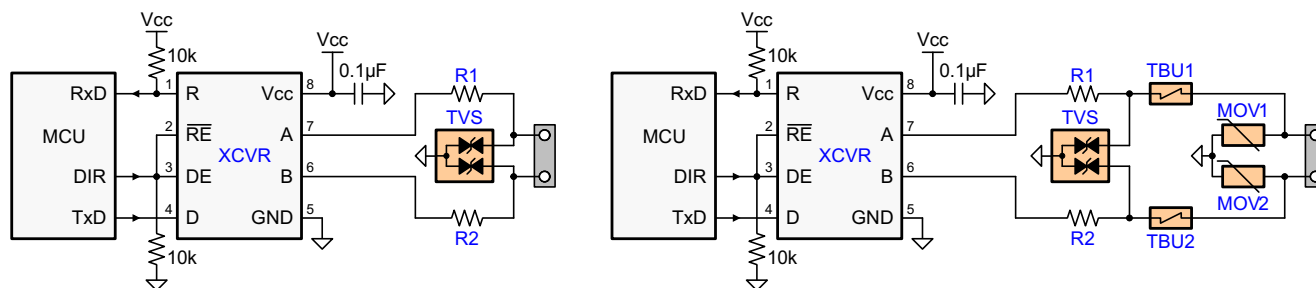

Figure 22. Transient Protections against ESD, EFT, and Surge Transients

The left-hand circuit provides surge protection of ≥ 500 -V surge transients, while the right-hand circuit can withstand surge transients of up to 5 kV.

9.2.2.2 Isolated Bus Node Design

Many RS-485 networks use isolated bus nodes to prevent the creation of unintended ground loops and their disruptive impact on signal integrity. An isolated bus node typically includes a microcontroller that connects to the bus transceiver via a multi-channel, digital isolator (Figure 23).

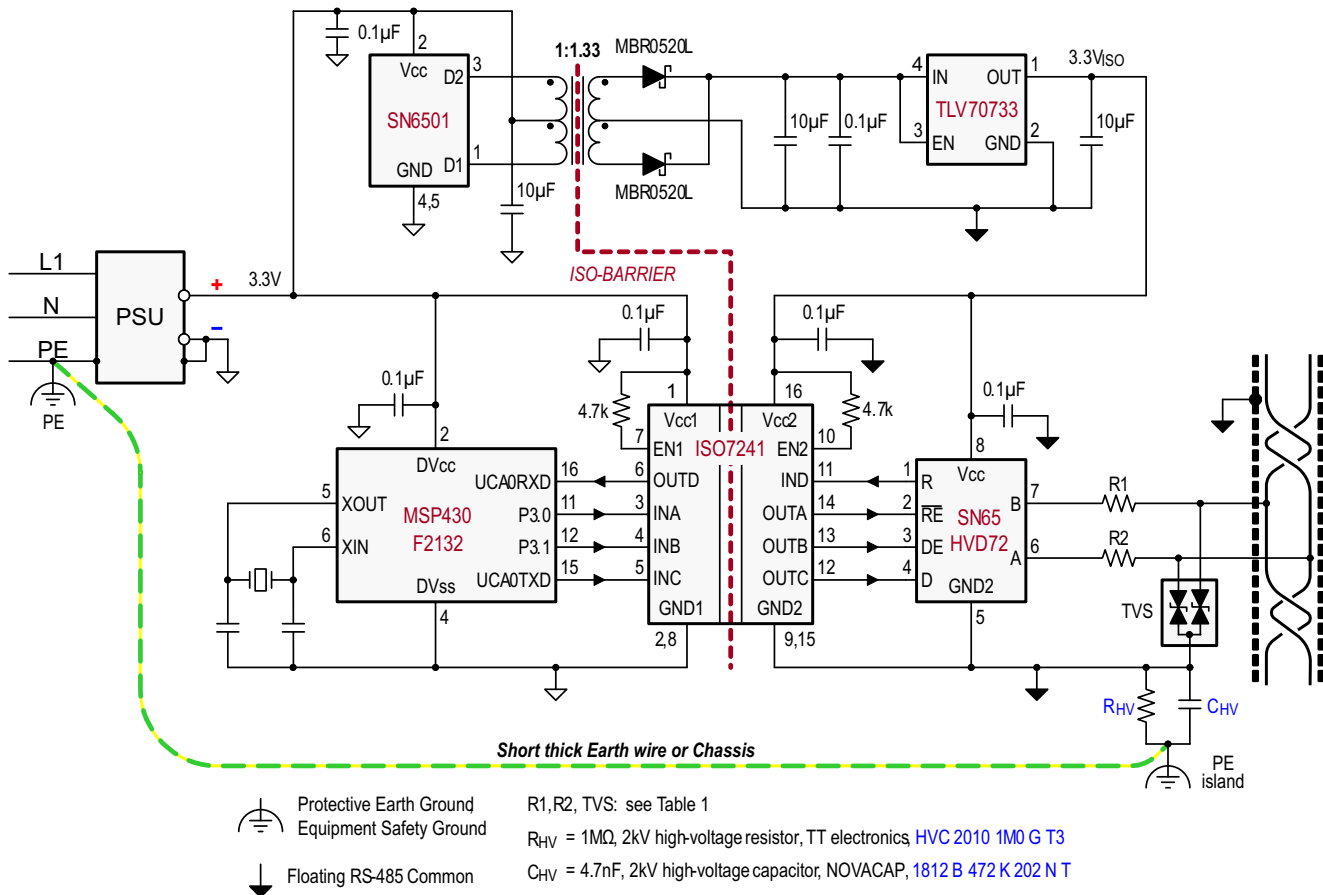

Figure 23. Isolated Bus Node with Transient Protection

Power isolation is accomplished using the push-pull transformer driver SN6501 and a low-cost LDO, TLV70733.

Signal isolation uses the quadruple digital isolator ISO7241. Notice that both enable inputs, EN₁ and EN₂, are pulled up via 4.7 k Ω resistors to limit their input currents during transient events.

While the transient protection is similar to the one in Figure 22 (left circuit), an additional high-voltage capacitor is used to divert transient energy from the floating RS-485 common further toward Protective Earth (PE) ground. This is necessary as noise transients on the bus are usually referred to Earth potential.

R_{HV} refers to a high voltage resistor, and in some applications even a varistor. This resistance is applied to prevent charging of the floating ground to dangerous potentials during normal operation.

Occasionally varistors are used instead of resistors to rapidly discharge C_{HV}, if it is expected that fast transients might charge C_{HV} to high-potentials.

Note that the PE island represents a copper island on the PCB for the provision of a short, thick Earth wire connecting this island to PE ground at the entrance of the power supply unit (PSU).

In equipment designs using a chassis, the PE connection is usually provided through the chassis itself. Typically the PE conductor is tied to the chassis at one end while the high-voltage components, C_{HV} and R_{HV}, are connecting to the chassis at the other end.

9.2.3 Application Curve

$R_L = 60 \Omega$

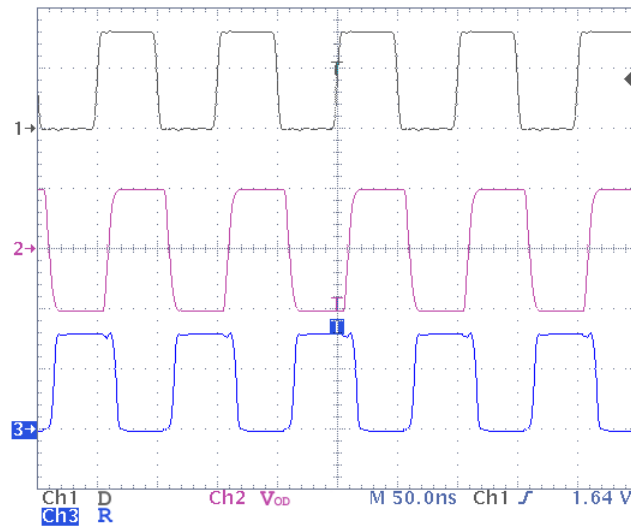

Figure 24. 20 Mbps

10 Power Supply Recommendations

To assure reliable operation at all data rates and supply voltages, each supply should be buffered with a 100-nF ceramic capacitor located as close to the supply pins as possible. The TPS76333 is a linear voltage regulator suitable for the 3.3-V supply.

See the SN6501 device data sheet ([SLLSEA0](#)) for isolated power supply designs.

11 Layout

11.1 Layout Guidelines

On-chip IEC ESD protection is sufficient for laboratory and portable equipment but often insufficient for EFT and surge transients occurring in industrial environments. Therefore, robust and reliable bus node design requires the use of external transient protection devices.

Because ESD and EFT transients have a wide frequency bandwidth from approximately 3 MHz to 3 GHz, high-frequency layout techniques must be applied during PCB design.

For a successful PCB design, start with the design of the protection circuit in mind.

- Place the protection circuitry close to the bus connector to prevent noise transients from entering the board.
- Use V_{CC} and ground planes to provide low-inductance. Note that high-frequency currents follow the path of least inductance and not the path of least impedance.
- Design the protection components into the direction of the signal path. Do not force the transients currents to divert from the signal path to reach the protection device.
- Apply 100-nF to 220-nF bypass capacitors as close as possible to the V_{CC} pins of transceiver, UART, and controller ICs on the board.
- Use at least two vias for V_{CC} and ground connections of bypass capacitors and protection devices to minimize effective via-inductance.
- Use 1-k Ω to 10-k Ω pullup or pulldown resistors for enable lines to limit noise currents in these lines during transient events.
- Insert pulse-proof series resistors into the A and B bus lines if the TVS clamping voltage is higher than the specified maximum voltage of the transceiver bus pins. These resistors limit the residual clamping current into the transceiver and prevent it from latching up.
- While pure TVS protection is sufficient for surge transients up to 1 kV, higher transients require metal-oxide varistors (MOVs) which reduce the transients to a few hundred volts of clamping voltage, and transient blocking units (TBUs) that limit transient current to 200 mA.

11.2 Layout Example

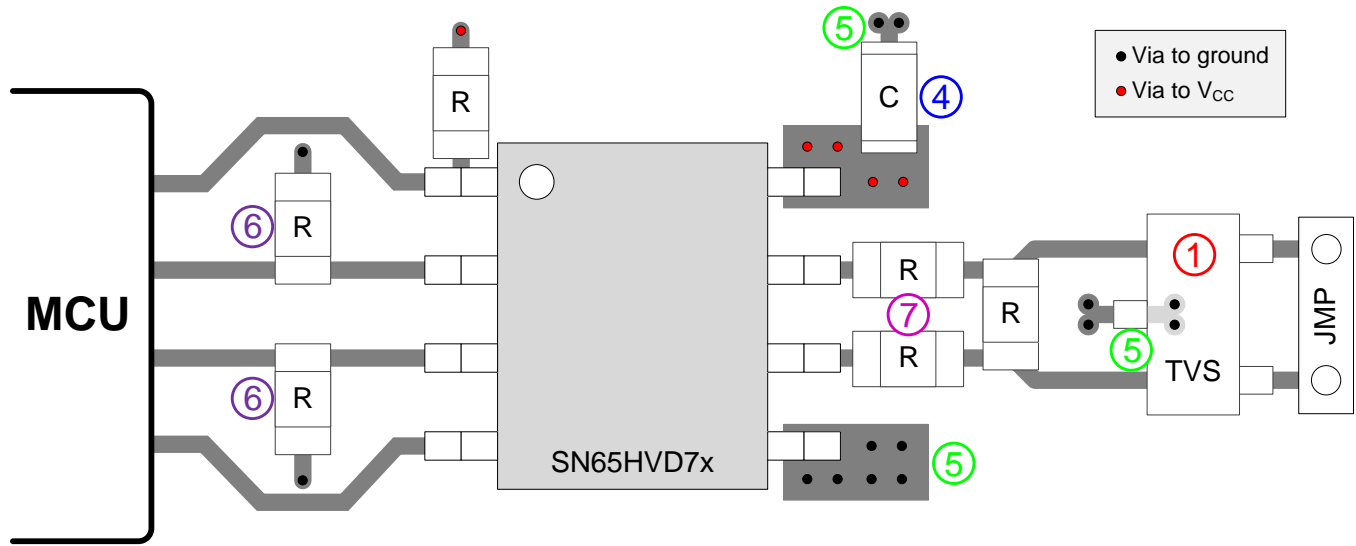

Figure 25. SN55HVD75-EP Half-Duplex Layout Example

12 Device and Documentation Support

12.1 Device Support

12.1.1 Third-Party Products Disclaimer

TI'S PUBLICATION OF INFORMATION REGARDING THIRD-PARTY PRODUCTS OR SERVICES DOES NOT CONSTITUTE AN ENDORSEMENT REGARDING THE SUITABILITY OF SUCH PRODUCTS OR SERVICES OR A WARRANTY, REPRESENTATION OR ENDORSEMENT OF SUCH PRODUCTS OR SERVICES, EITHER ALONE OR IN COMBINATION WITH ANY TI PRODUCT OR SERVICE.

12.2 Community Resources

The following links connect to TI community resources. Linked contents are provided "AS IS" by the respective contributors. They do not constitute TI specifications and do not necessarily reflect TI's views; see TI's [Terms of Use](#).

TI E2E™ Online Community *TI's Engineer-to-Engineer (E2E) Community*. Created to foster collaboration among engineers. At e2e.ti.com, you can ask questions, share knowledge, explore ideas and help solve problems with fellow engineers.

Design Support *TI's Design Support* Quickly find helpful E2E forums along with design support tools and contact information for technical support.

12.3 Trademarks

E2E is a trademark of Texas Instruments.
All other trademarks are the property of their respective owners.

12.4 Electrostatic Discharge Caution



These devices have limited built-in ESD protection. The leads should be shorted together or the device placed in conductive foam during storage or handling to prevent electrostatic damage to the MOS gates.

12.5 Glossary

[SLYZ022](#) — *TI Glossary*.

This glossary lists and explains terms, acronyms, and definitions.

13 Mechanical, Packaging, and Orderable Information

The following pages include mechanical, packaging, and orderable information. This information is the most current data available for the designated devices. This data is subject to change without notice and revision of this document. For browser-based versions of this data sheet, refer to the left-hand navigation.

PACKAGING INFORMATION

Orderable Device	Status (1)	Package Type	Package Drawing	Pins	Package Qty	Eco Plan (2)	Lead/Ball Finish (6)	MSL Peak Temp (3)	Op Temp (°C)	Device Marking (4/5)	Samples
SN55HVD75DRBREP	ACTIVE	SON	DRB	8	3000	Green (RoHS & no Sb/Br)	CU NIPDAU	Level-2-260C-1 YEAR	-55 to 125	HVD75M	Samples
V62/15608-01XE	ACTIVE	SON	DRB	8	3000	Green (RoHS & no Sb/Br)	CU NIPDAU	Level-2-260C-1 YEAR	-55 to 125	HVD75M	Samples

(1) The marketing status values are defined as follows:

ACTIVE: Product device recommended for new designs.

LIFEBUY: TI has announced that the device will be discontinued, and a lifetime-buy period is in effect.

NRND: Not recommended for new designs. Device is in production to support existing customers, but TI does not recommend using this part in a new design.

PREVIEW: Device has been announced but is not in production. Samples may or may not be available.

OBSELETE: TI has discontinued the production of the device.

(2) Eco Plan - The planned eco-friendly classification: Pb-Free (RoHS), Pb-Free (RoHS Exempt), or Green (RoHS & no Sb/Br) - please check <http://www.ti.com/productcontent> for the latest availability information and additional product content details.

TBD: The Pb-Free/Green conversion plan has not been defined.

Pb-Free (RoHS): TI's terms "Lead-Free" or "Pb-Free" mean semiconductor products that are compatible with the current RoHS requirements for all 6 substances, including the requirement that lead not exceed 0.1% by weight in homogeneous materials. Where designed to be soldered at high temperatures, TI Pb-Free products are suitable for use in specified lead-free processes.

Pb-Free (RoHS Exempt): This component has a RoHS exemption for either 1) lead-based flip-chip solder bumps used between the die and package, or 2) lead-based die adhesive used between the die and leadframe. The component is otherwise considered Pb-Free (RoHS compatible) as defined above.

Green (RoHS & no Sb/Br): TI defines "Green" to mean Pb-Free (RoHS compatible), and free of Bromine (Br) and Antimony (Sb) based flame retardants (Br or Sb do not exceed 0.1% by weight in homogeneous material)

(3) MSL, Peak Temp. - The Moisture Sensitivity Level rating according to the JEDEC industry standard classifications, and peak solder temperature.

(4) There may be additional marking, which relates to the logo, the lot trace code information, or the environmental category on the device.

(5) Multiple Device Markings will be inside parentheses. Only one Device Marking contained in parentheses and separated by a "~" will appear on a device. If a line is indented then it is a continuation of the previous line and the two combined represent the entire Device Marking for that device.

(6) Lead/Ball Finish - Orderable Devices may have multiple material finish options. Finish options are separated by a vertical ruled line. Lead/Ball Finish values may wrap to two lines if the finish value exceeds the maximum column width.

Important Information and Disclaimer:The information provided on this page represents TI's knowledge and belief as of the date that it is provided. TI bases its knowledge and belief on information provided by third parties, and makes no representation or warranty as to the accuracy of such information. Efforts are underway to better integrate information from third parties. TI has taken and continues to take reasonable steps to provide representative and accurate information but may not have conducted destructive testing or chemical analysis on incoming materials and chemicals. TI and TI suppliers consider certain information to be proprietary, and thus CAS numbers and other limited information may not be available for release.

In no event shall TI's liability arising out of such information exceed the total purchase price of the TI part(s) at issue in this document sold by TI to Customer on an annual basis.

TAPE AND REEL INFORMATION



QUADRANT ASSIGNMENTS FOR PIN 1 ORIENTATION IN TAPE



*All dimensions are nominal

Device	Package Type	Package Drawing	Pins	SPQ	Reel Diameter (mm)	Reel Width W1 (mm)	A0 (mm)	B0 (mm)	K0 (mm)	P1 (mm)	W (mm)	Pin1 Quadrant
SN55HVD75DRBREP	SON	DRB	8	3000	330.0	12.4	3.3	3.3	1.1	8.0	12.0	Q2

TAPE AND REEL BOX DIMENSIONS



*All dimensions are nominal

Device	Package Type	Package Drawing	Pins	SPQ	Length (mm)	Width (mm)	Height (mm)
SN55HVD75DRBREP	SON	DRB	8	3000	367.0	367.0	35.0

DRB (S-PVSON-N8)

PLASTIC SMALL OUTLINE NO-LEAD

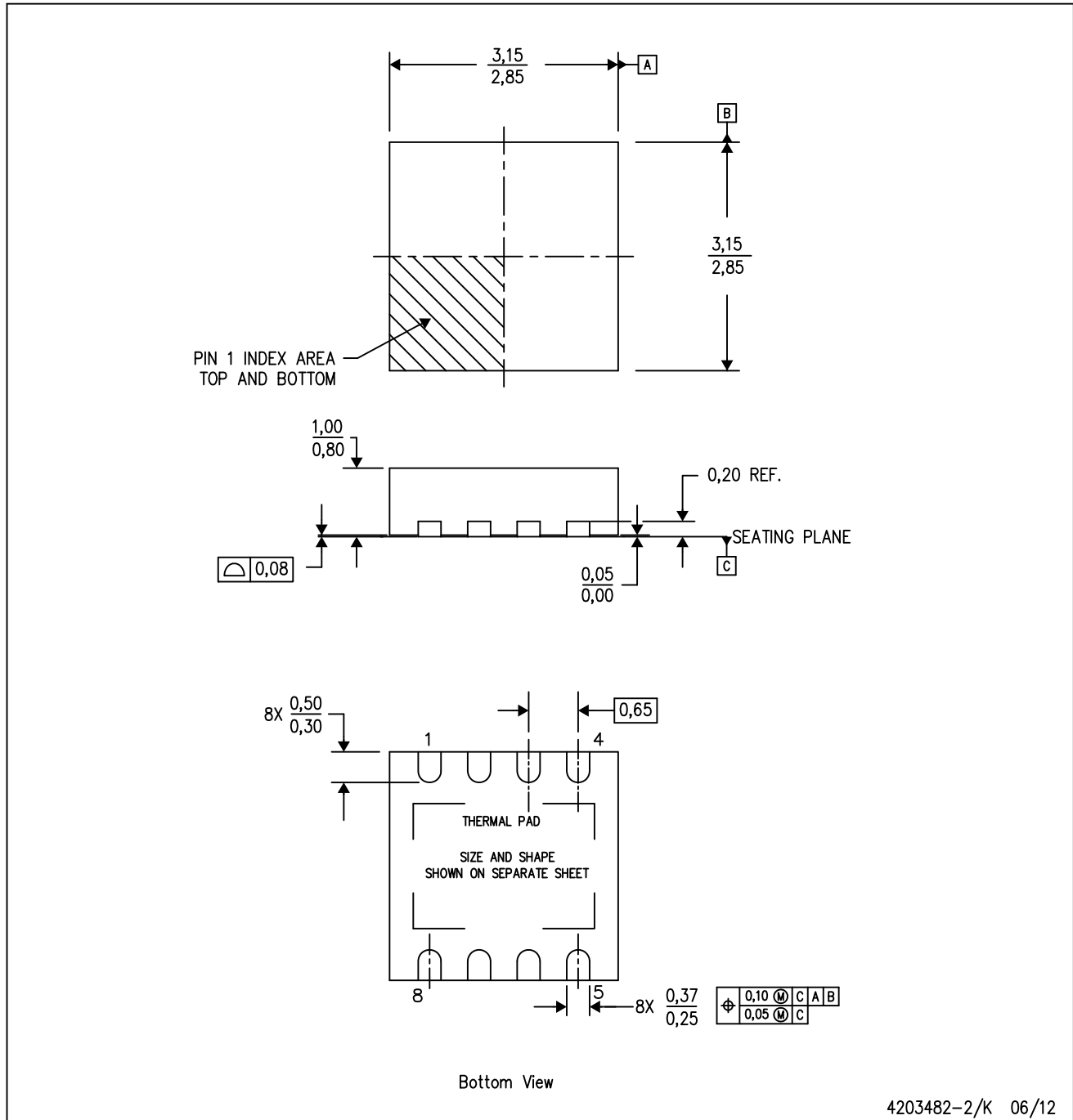

- NOTES:
- All linear dimensions are in millimeters. Dimensioning and tolerancing per ASME Y14.5M-1994.
 - This drawing is subject to change without notice.
 - Small Outline No-Lead (SON) package configuration.
 - The package thermal pad must be soldered to the board for thermal and mechanical performance.
 - See the additional figure in the Product Data Sheet for details regarding the exposed thermal pad features and dimensions.

THERMAL INFORMATION

This package incorporates an exposed thermal pad that is designed to be attached directly to an external heatsink. The thermal pad must be soldered directly to the printed circuit board (PCB). After soldering, the PCB can be used as a heatsink. In addition, through the use of thermal vias, the thermal pad can be attached directly to the appropriate copper plane shown in the electrical schematic for the device, or alternatively, can be attached to a special heatsink structure designed into the PCB. This design optimizes the heat transfer from the integrated circuit (IC).

For information on the Quad Flatpack No-Lead (QFN) package and its advantages, refer to Application Report, QFN/SON PCB Attachment, Texas Instruments Literature No. SLUA271. This document is available at www.ti.com.

The exposed thermal pad dimensions for this package are shown in the following illustration.

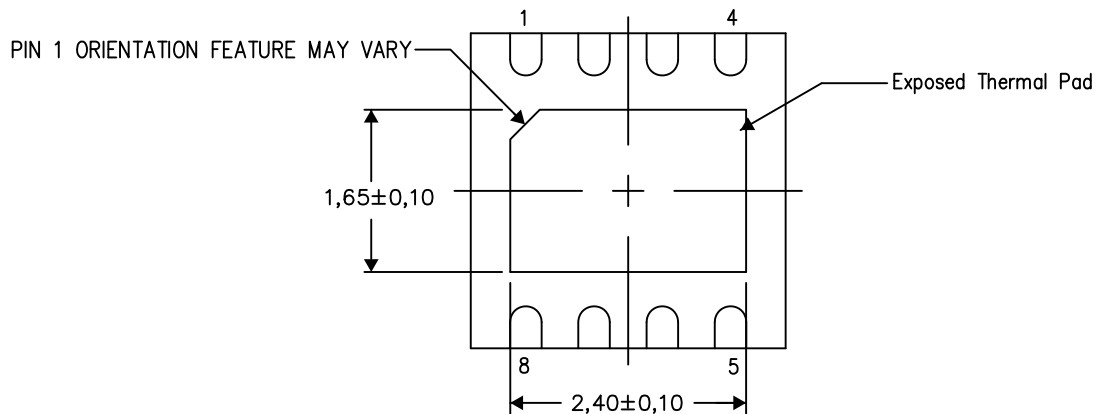

Bottom View

Exposed Thermal Pad Dimensions

4206340-3/T 08/15

NOTE: All linear dimensions are in millimeters

DRB (S-PVSON-N8)

PLASTIC SMALL OUTLINE NO-LEAD

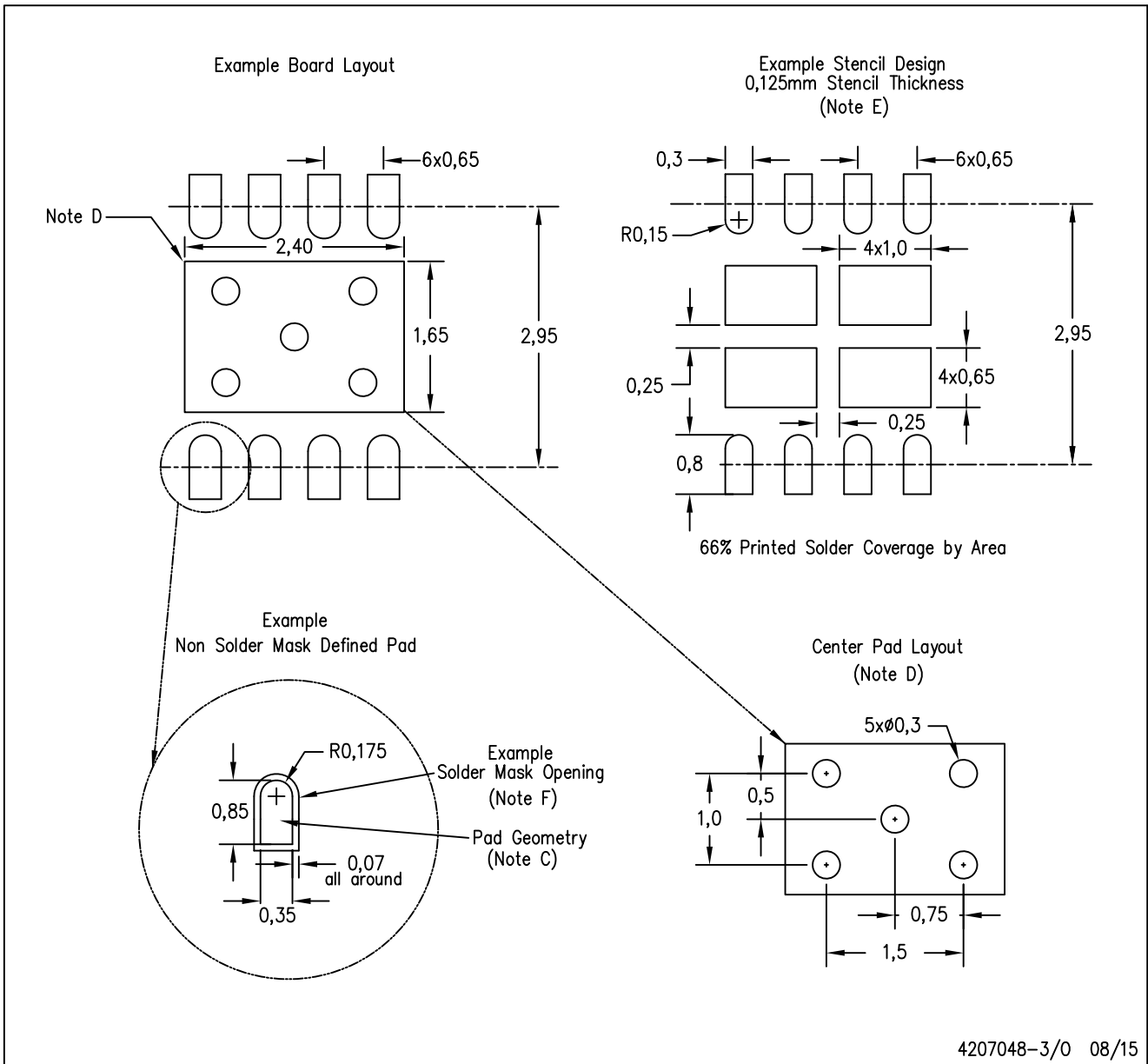

- NOTES:
- A. All linear dimensions are in millimeters.
 - B. This drawing is subject to change without notice.
 - C. Publication IPC-7351 is recommended for alternate designs.
 - D. This package is designed to be soldered to a thermal pad on the board. Refer to Application Note, QFN Packages, Texas Instruments Literature No. SLUA271, and also the Product Data Sheets for specific thermal information, via requirements, and recommended board layout. These documents are available at www.ti.com <<http://www.ti.com>>.
 - E. Laser cutting apertures with trapezoidal walls and also rounding corners will offer better paste release. Customers should contact their board assembly site for stencil design recommendations. Refer to IPC 7525 for stencil design considerations.
 - F. Customers should contact their board fabrication site for solder mask tolerances.

IMPORTANT NOTICE

Texas Instruments Incorporated and its subsidiaries (TI) reserve the right to make corrections, enhancements, improvements and other changes to its semiconductor products and services per JESD46, latest issue, and to discontinue any product or service per JESD48, latest issue. Buyers should obtain the latest relevant information before placing orders and should verify that such information is current and complete. All semiconductor products (also referred to herein as "components") are sold subject to TI's terms and conditions of sale supplied at the time of order acknowledgment.

TI warrants performance of its components to the specifications applicable at the time of sale, in accordance with the warranty in TI's terms and conditions of sale of semiconductor products. Testing and other quality control techniques are used to the extent TI deems necessary to support this warranty. Except where mandated by applicable law, testing of all parameters of each component is not necessarily performed.

TI assumes no liability for applications assistance or the design of Buyers' products. Buyers are responsible for their products and applications using TI components. To minimize the risks associated with Buyers' products and applications, Buyers should provide adequate design and operating safeguards.

TI does not warrant or represent that any license, either express or implied, is granted under any patent right, copyright, mask work right, or other intellectual property right relating to any combination, machine, or process in which TI components or services are used. Information published by TI regarding third-party products or services does not constitute a license to use such products or services or a warranty or endorsement thereof. Use of such information may require a license from a third party under the patents or other intellectual property of the third party, or a license from TI under the patents or other intellectual property of TI.

Reproduction of significant portions of TI information in TI data books or data sheets is permissible only if reproduction is without alteration and is accompanied by all associated warranties, conditions, limitations, and notices. TI is not responsible or liable for such altered documentation. Information of third parties may be subject to additional restrictions.

Resale of TI components or services with statements different from or beyond the parameters stated by TI for that component or service voids all express and any implied warranties for the associated TI component or service and is an unfair and deceptive business practice. TI is not responsible or liable for any such statements.

Buyer acknowledges and agrees that it is solely responsible for compliance with all legal, regulatory and safety-related requirements concerning its products, and any use of TI components in its applications, notwithstanding any applications-related information or support that may be provided by TI. Buyer represents and agrees that it has all the necessary expertise to create and implement safeguards which anticipate dangerous consequences of failures, monitor failures and their consequences, lessen the likelihood of failures that might cause harm and take appropriate remedial actions. Buyer will fully indemnify TI and its representatives against any damages arising out of the use of any TI components in safety-critical applications.

In some cases, TI components may be promoted specifically to facilitate safety-related applications. With such components, TI's goal is to help enable customers to design and create their own end-product solutions that meet applicable functional safety standards and requirements. Nonetheless, such components are subject to these terms.

No TI components are authorized for use in FDA Class III (or similar life-critical medical equipment) unless authorized officers of the parties have executed a special agreement specifically governing such use.

Only those TI components which TI has specifically designated as military grade or "enhanced plastic" are designed and intended for use in military/aerospace applications or environments. Buyer acknowledges and agrees that any military or aerospace use of TI components which have **not** been so designated is solely at the Buyer's risk, and that Buyer is solely responsible for compliance with all legal and regulatory requirements in connection with such use.

TI has specifically designated certain components as meeting ISO/TS16949 requirements, mainly for automotive use. In any case of use of non-designated products, TI will not be responsible for any failure to meet ISO/TS16949.

Products

Audio	www.ti.com/audio
Amplifiers	amplifier.ti.com
Data Converters	dataconverter.ti.com
DLP® Products	www.dlp.com
DSP	dsp.ti.com
Clocks and Timers	www.ti.com/clocks
Interface	interface.ti.com
Logic	logic.ti.com
Power Mgmt	power.ti.com
Microcontrollers	microcontroller.ti.com
RFID	www.ti-rfid.com
OMAP Applications Processors	www.ti.com/omap
Wireless Connectivity	www.ti.com/wirelessconnectivity

Applications

Automotive and Transportation	www.ti.com/automotive
Communications and Telecom	www.ti.com/communications
Computers and Peripherals	www.ti.com/computers
Consumer Electronics	www.ti.com/consumer-apps
Energy and Lighting	www.ti.com/energy
Industrial	www.ti.com/industrial
Medical	www.ti.com/medical
Security	www.ti.com/security
Space, Avionics and Defense	www.ti.com/space-avionics-defense
Video and Imaging	www.ti.com/video

TI E2E Community

e2e.ti.com