

FEATURES

- V_{BO} : 32V and 40V
- LOW BREAKOVER CURRENT

DESCRIPTION

Functioning as a trigger diode with a fixed voltage reference, the DB3/DB4 series can be used in conjunction with triacs for simplified gate control circuits or as a starting element in fluorescent lamp ballasts.

A new surface mount version is now available in SOT-23 package, providing reduced space and compatibility with automatic pick and place equipment.

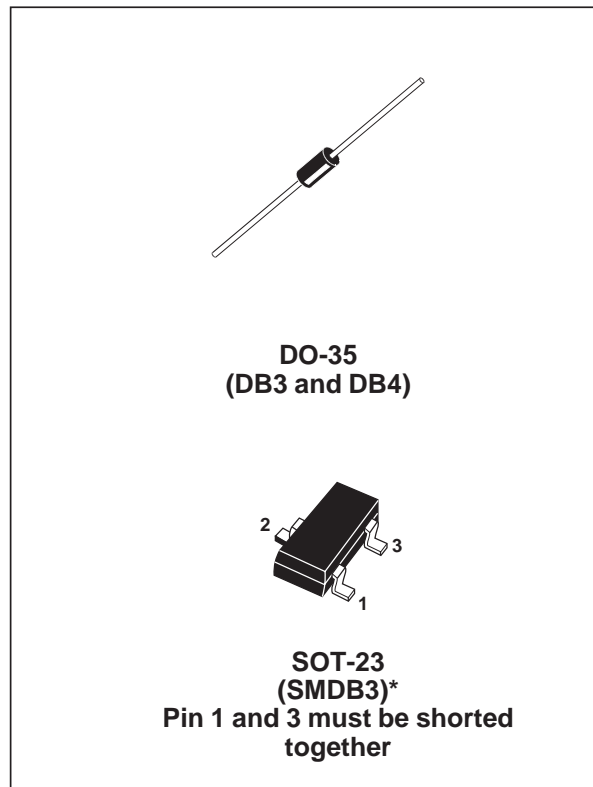

ABSOLUTE MAXIMUM RATINGS (limiting values)

Symbol	Parameter	Value	Unit	
I_{TRM}	Repetitive peak on-state current $t_p = 20 \mu s$ $F = 120 \text{ Hz}$	SMDB3	1.00	A
		DB3 / DB4	2.00	
T_{stg} T_j	Storage temperature range Operating junction temperature range	- 40 to + 125	°C	

Note: * SMDB3 indicated as Preliminary spec as product is still in development stage.

DB3 DB4 SMDB3

ELECTRICAL CHARACTERISTICS (Tj = 25°C unless otherwise specified)

Symbol	Parameter	Test Conditions	SMDB3	DB3	DB4	Unit	
V _{BO}	Breakover voltage *	C = 22nF **	MIN.	28	28	35	V
			TYP.	32	32	40	
			MAX.	36	36	45	
V _{BO1} - V _{BO2}	Breakover voltage symmetry	C = 22nF **	MAX.	3		V	
ΔV	Dynamic breakover voltage *	V _{BO} and V _F at 10mA	MIN.	10	5	V	
V _O	Output voltage *	see diagram 2 (R=20Ω)	MIN.	10	5	V	
I _{BO}	Breakover current *	C = 22nF **	MAX.	10	50	μA	
t _r	Rise time *	see diagram 3	MAX.	0.50	2	μs	
I _R	Leakage current *	V _R = 0.5 V _{BO} max	MAX.	1	10	μA	
I _P	Peak current *	see diagram 2 (Gate)	MIN.	1	0.30	A	

* Applicable to both forward and reverse directions.

** Connected in parallel to the device.

PRODUCT SELECTOR

Part Number	V _{BO}	Package
SMDB3	28 - 36	SOT-23
DB3	28 - 36	DO-35
DB4	35 - 45	DO-35

ORDERING INFORMATION

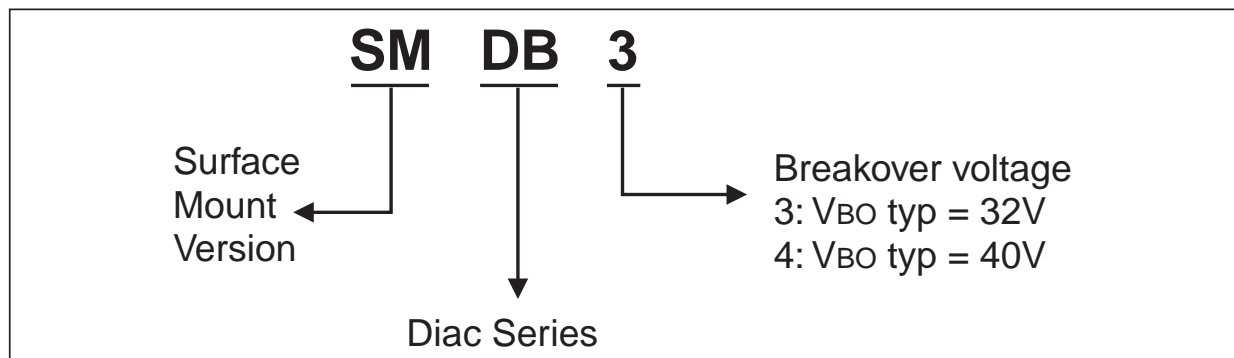

OTHER INFORMATION

Part Number	Marking	Weight	Base Quantity	Packing Mode
SMDB3	DB3	0.01 g	3000	Tape & Reel
DB3	DB3 (Blue Body Coat)	0.15 g	5000	Tape & Reel
DB4	DB4 (Blue Body Coat)	0.15 g	5000	Tape & Reel

Diagram 1: Voltage - current characteristic curve.

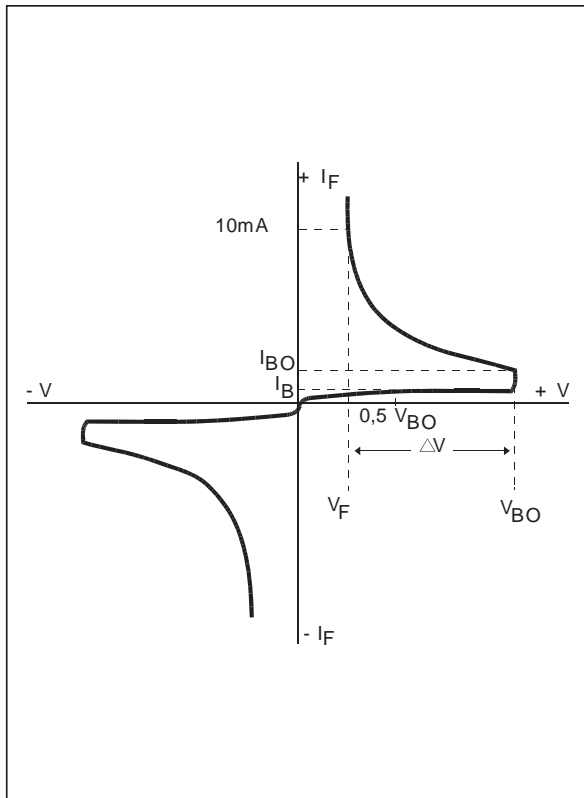

Diagram 2: Test circuit.

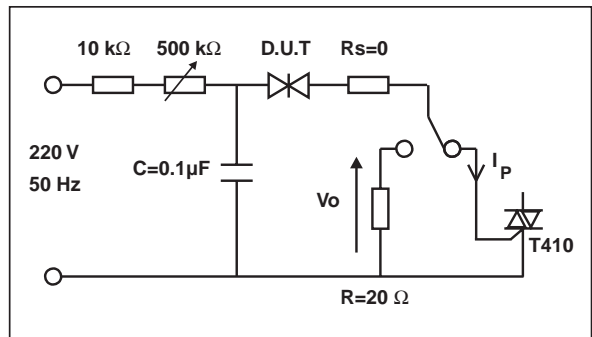

Diagram 3: Rise time measurement.

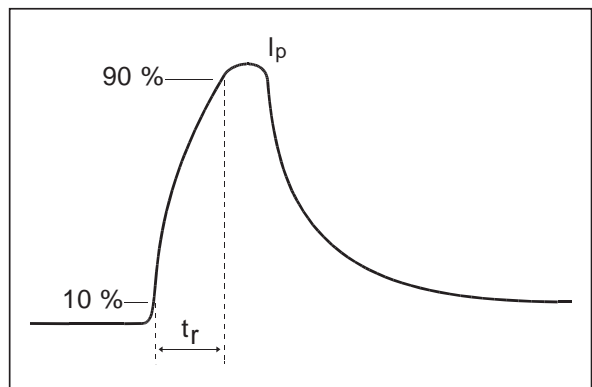

Fig. 1: Relative variation of VBO versus junction temperature (typical values).

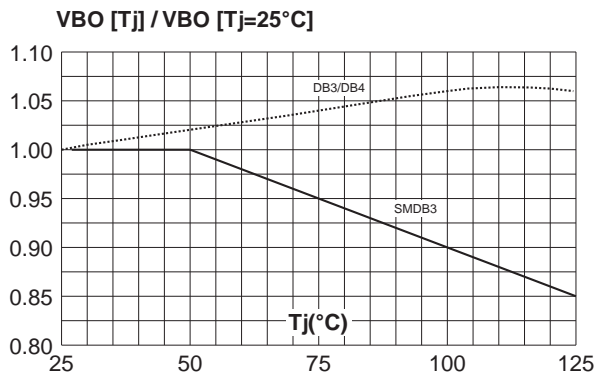

Fig. 2: Repetitive peak pulse current versus pulse duration (maximum values).

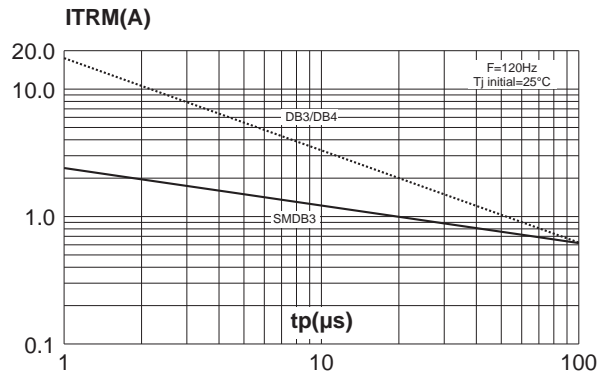
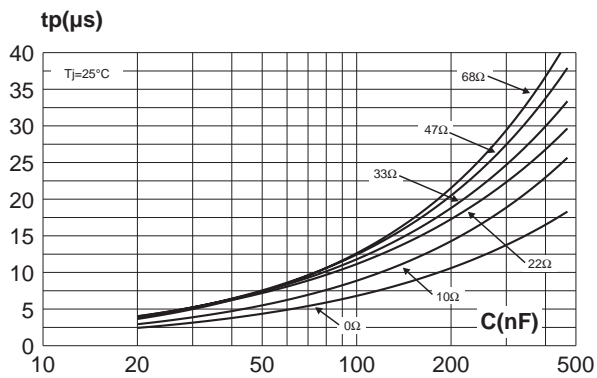

Fig. 3: Time duration while current pulse is higher 50mA versus C and Rs (typical values).



PACKAGE MECHANICAL DATA (in millimeters)
DO-35

REF.	DIMENSIONS			
	Millimeters		Inches	
	Min.	Max.	Min.	Max.
A	3.05	4.50	0.120	0.177
B	1.53	2.00	0.060	0.079
C	28.00		1.102	
D	0.458	0.558	0.018	0.022

PACKAGE MECHANICAL DATA (in millimeters)

SOT-23

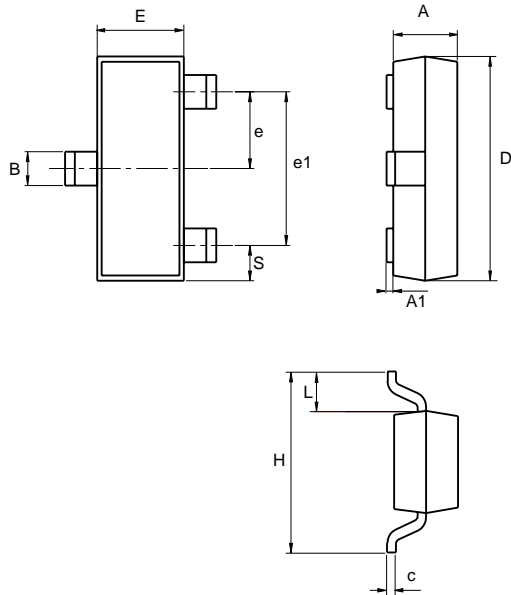

REF.	DIMENSIONS			
	Millimeters		Inches	
	Min.	Max.	Min.	Max.
A	0.89	1.4	0.035	0.055
A1	0	0.1	0	0.004
B	0.3	0.51	0.012	0.02
c	0.085	0.18	0.003	0.007
D	2.75	3.04	0.108	0.12
e	0.85	1.05	0.033	0.041
e1	1.7	2.1	0.067	0.083
E	1.2	1.6	0.047	0.063
H	2.1	2.75	0.083	0.108
L	0.6 typ.		0.024 typ.	
S	0.35	0.65	0.014	0.026

FOOTPRINT

