

The SiI 170B is a DVI-compliant transmitter with integrated High-bandwidth Digital Content Protection (HDCP). By integrating HDCP, the SiI 170B enables consumer electronics and PC manufacturers to build electronic systems capable of sending high-definition video over a secure digital link to a display device (HDTV, LCD monitor, projector). SiI 170B-enabled products meet requirements set forth by the Motion Picture Association (MPA) for the distribution of high-definition video.

Based on the popular DVI specification, HDCP was developed by Intel with contributions from Silicon Image. HDCP utilizes secret keys to authenticate and encode the digital video stream. The HDCP encryption block is seamlessly integrated into the SiI 170B. Integrated, pre-programmed HDCP keys significantly simplify manufacturing while providing the most secure solution. The SiI 170B is pin compatible with the SiI 168.

The SiI 170B uses Silicon Image's PanelLink® Digital technology to support displays ranging from VGA to UXGA resolutions (1600 x 1200) at speeds ranging from 25-165 MHz. Three TMDS® data channels send data at up to 1.65 Gbps per channel. A highly flexible graphics interface can be configured for either 12-bit (1/2 pixel/clock edge) or 24-bit mode (1 pixel/clock edge) for true color (16.7 million) support.

Applications

- Digital Set-top Boxes
- DVD Players
- D-VHS Players
- A/V Receivers
- PCs
- High-end Graphic Boards

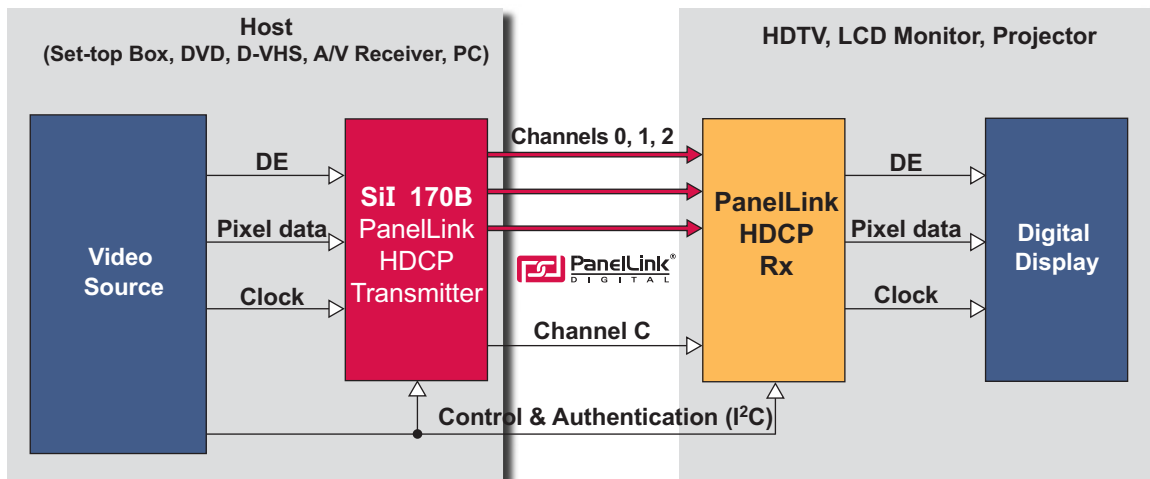

SiI 170B Features

PanelLink® Transmitter

- Scalable bandwidth from 25 to 165 Mpps (VGA to UXGA)
- Three TMDS® data channels capable of transferring up to 1.65 Gbps per channel
- Data Enable (DE) generated from HSYNC and VSYNC
- Inter-pair skew tolerance up to 1 input clock cycle (6 ns at 165 MHz)
- Adjustable TMDS low-voltage swing signaling for long-distance support
- DC-balanced signals for direct coupling to fiber-optic ready modules
- Operates with all PanelLink receivers
- Pin-compatible with SiI164/168

Content Protection

- Integrated High-bandwidth Digital Content Protection (HDCP)
- Enables protected transmission of high-definition content through highest digital bandwidth available
- Pre-programmed, integrated HDCP keys
- Encryption of full bandwidth (uncompressed) video
- Supports 480p, 720p and 1080i

Input

- Flexible graphics controller interface
- Supports 12-bit or 24-bit (1 pixel/clock) inputs for true color (16.7 million)
- Programmable low-voltage interface (1.0V – 1.8V) as well as 3.3V CMOS interface voltages
- De-skewing option to vary clock to data timing

Part Number - SiI170BCL64

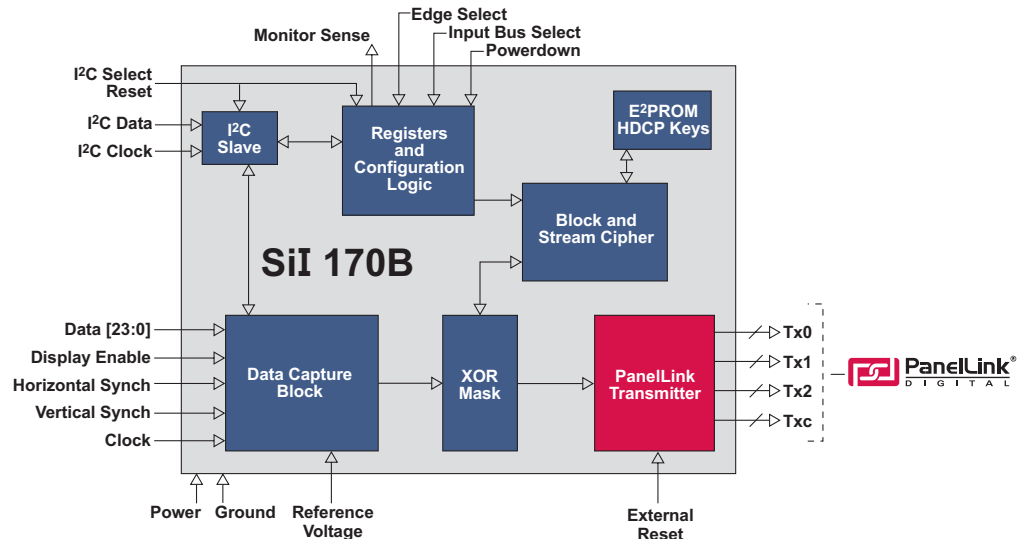

- Supports dual-edge single clock or single-edge dual clock in 12-bit mode
- Supports either single or dual edge clocking in 24-bit mode
- Parallel data can be latched on either the positive or negative edge of clock
- Programmable through I²C interface

Power Management

- 3.3V core provides low-power operation
- Standby mode consumes only 1mW

Silicon Image's SiI 170B Starter Kit

The CPI70BDVI Starter Kit includes all the hardware, software and documentation to quickly bring new HDCP-ready hosts to production.

Contents include:

Hardware

- SiI 170B Tx board
- HDCP Rx board
- DVI cables
- Parallel port cable
- Power supplies

Software

- HDCP Evaluation Software

Documentation

- SiI 170B Starter Kit User's Guide
- SiI 170B Data Sheet
- Reference schematics for Tx and Rx card