

Si3219x: ProSLIC® Single FXS Solution

ProSLIC® Single-Channel FXS Solutions

The Si3219x Single FXS ProSLIC® devices implement a complete foreign exchange station (FXS) telephony interface solution in a single package that conforms to all relevant global specifications. The Si3219x ProSLIC ICs operate from a 3.3 V supply and have a 3-wire ISI digital interface with 1.8 to 3.3 V I/O. The Si3219x devices are designed to operate with a capacitive boost tracking battery supply for lower power, cost, and footprint than other tracking supplies in the industry. Self-testing and metallic loop testing (MLT) are facilitated by the built-in DSP, monitor ADC, and test load. The devices are available with wideband audio for better-than-PSTN voice quality and DTMF detection. The Si3219x devices are available in a 4 x 6 mm, 38-pin QFN package.

Applications:

- VoIP Gateways and Routers
- xDSL IADs
- Optical Network Terminals/Units (ONT/U)
- Analog Terminal Adapters (ATA)
- Cable eMTA
- Wireless Fixed Terminals (WFT)
- Wireless Local Loop (WLL)
- WiMAX CPE

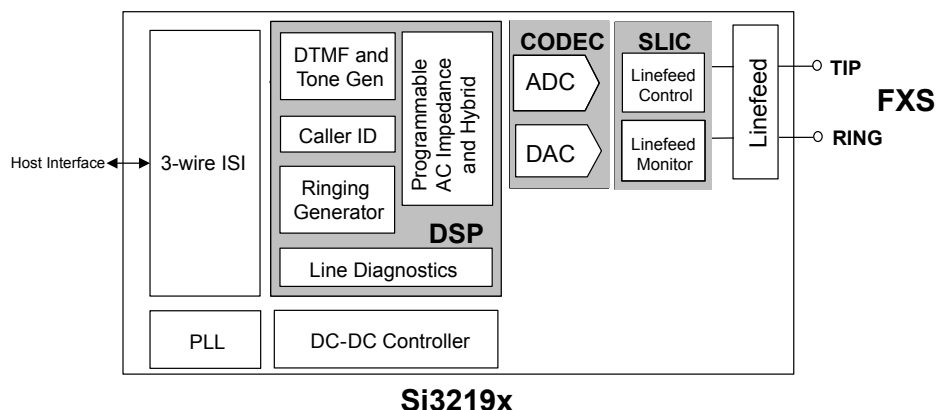

KEY FEATURES

- Complete FXS solution in a single 4 x 6 mm package
- Performs all BORSCHT functions
- Ideal for short- or medium-loop applications
- Ultra-low power consumption
- Patented low-power ringing
- Adaptive ringing
- Dynamic overhead control
- Ringing current limiting
- Simplified configuration and diagnostics
 - Supported by ProSLIC API
 - Audio diagnostics with loopback
 - Integrated test load
- Global programmability
- Wideband voice support
- On-hook transmission
- Loop or ground start operation
- Smooth polarity reversal
- A-Law/ μ -Law companding, linear PCM
- Flexible integrated tracking dc-dc controller supporting patent-pending low-cost capacitive boost configuration
- Software-programmable parameters:
 - Ringing frequency, amplitude, cadence, and waveshape
 - Two-wire ac impedance
 - Transhybrid balance
 - DC current loop feed (10–45 mA)
 - Loop closure and ring trip thresholds
 - Ground key detect threshold
- Pulse metering
- DTMF generation
- DTMF detection (Si32193)
- 3.3 V operation
- Support for 1.8 V I/O
- Maximum battery up to –100 V
- Pb-free/RoHS-compliant packaging
- 3-wire Integrated Serial Interface (ISI)

Table of Contents

1. Ordering Guide	3
1.1 Product Identification	4
2. Functional Description	5
3. Electrical Specifications	6
4. FXS Features	18
4.1 DC Feed Characteristics	18
4.2 Linefeed Operation States	18
4.3 Line Voltage and Current Monitoring	18
4.4 Power Monitoring and Power Fault Detection	18
4.5 Thermal Overload Shutdown	19
4.6 Loop Closure Detection	19
4.7 Ground Key Detection	19
4.8 Ringing Generation	19
4.9 Polarity Reversal	20
4.10 Two-wire Impedance Synthesis	20
4.11 Transhybrid Balance Figure	20
4.12 Tone Generators	20
4.13 DTMF Detection (Si32193 Only)	20
4.14 Pulse Metering	20
4.15 DC-DC Controller	20
4.16 Wideband Audio	20
4.17 Test Facilities	21
5. System Interfaces	22
5.1 Integrated Serial Interface	22
5.2 Input/Output Voltage Selection	22
6. Pin Descriptions	23
6.1 Pin Descriptions: 38 Pin QFN (Si32192/3)	23
7. Package Outline	26
7.1 Package Outline: 38-Pin QFN	26
8. Land Pattern	28
8.1 Land Pattern: 38-Pin QFN	28
9. Top Marking	30
9.1 Top Marking 38-pin QFN	30
10. Revision History	31

1. Ordering Guide

Table 1.1. Si3219x Ordering Guide

P/N	Description	Package Type ²	Max V _{BAT}	Temperature
Si32192-A-FM1	Wideband FXS, ISI interface, parametric MLT	QFN38	-100 V	0 to 70 °C
Si32192-A-GM1	Wideband FXS, ISI interface, parametric MLT	QFN38	-100 V	-40 to 85 °C
Si32193-A-FM1	Wideband FXS, ISI interface, parametric MLT, DTMF detection	QFN38	-100 V	0 to 70 °C
Si32193-A-GM1	Wideband FXS, ISI interface, parametric MLT, DTMF detection	QFN38	-100 V	-40 to 85 °C
Si32192-A-ZM1	Wideband FXS, ISI interface, parametric MLT, customer-specific	QFN38	-100 V	0 to 70 °C
Si32192-A-ZM2	Wideband FXS, ISI interface, parametric MLT, customer-specific	QFN38	-100 V	0 to 70 °C
Si32193-A-ZM1	Wideband FXS, ISI interface, parametric MLT, DTMF detection, customer-specific	QFN38	-100 V	0 to 70 °C
Si32193-A-ZM2	Wideband FXS, ISI interface, parametric MLT, DTMF detection, customer-specific	QFN38	-100 V	0 to 70 °C

Note:

- Adding the suffix "R" to the part number (e.g. Si3219x-A-FMR) denotes tape and reel.
- QFN - Quad-Flat No-leads.

Table 1.2. Ordering GuideSi3219x Evaluation Kits

Part Number	Description	V _{BAT} Max ¹
Si32193ACB10SL0EVB	ISI Wideband FXS with DTMF detection and low-cost capacitive boost dc-dc converter EVB	-100 V

Note:

- EVB V_{BAT} max may be limited by BOM option.

1.1 Product Identification

The product identification number is a finished goods part number or is specified by a finished goods part number, such as a special customer part number.

Example:

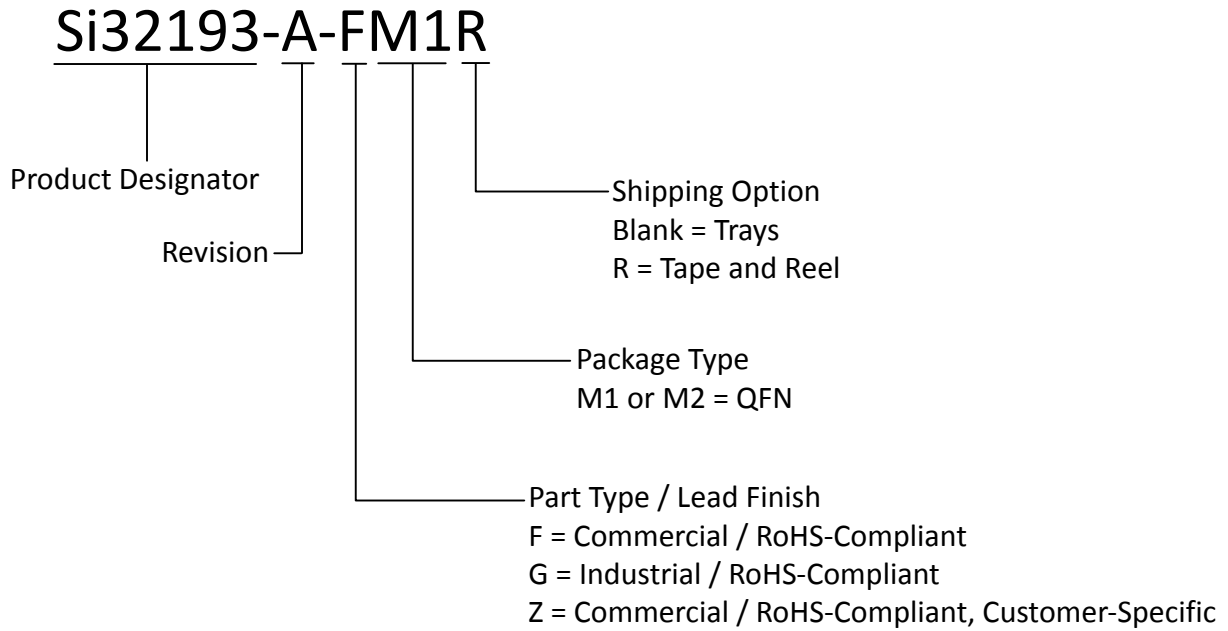

2. Functional Description

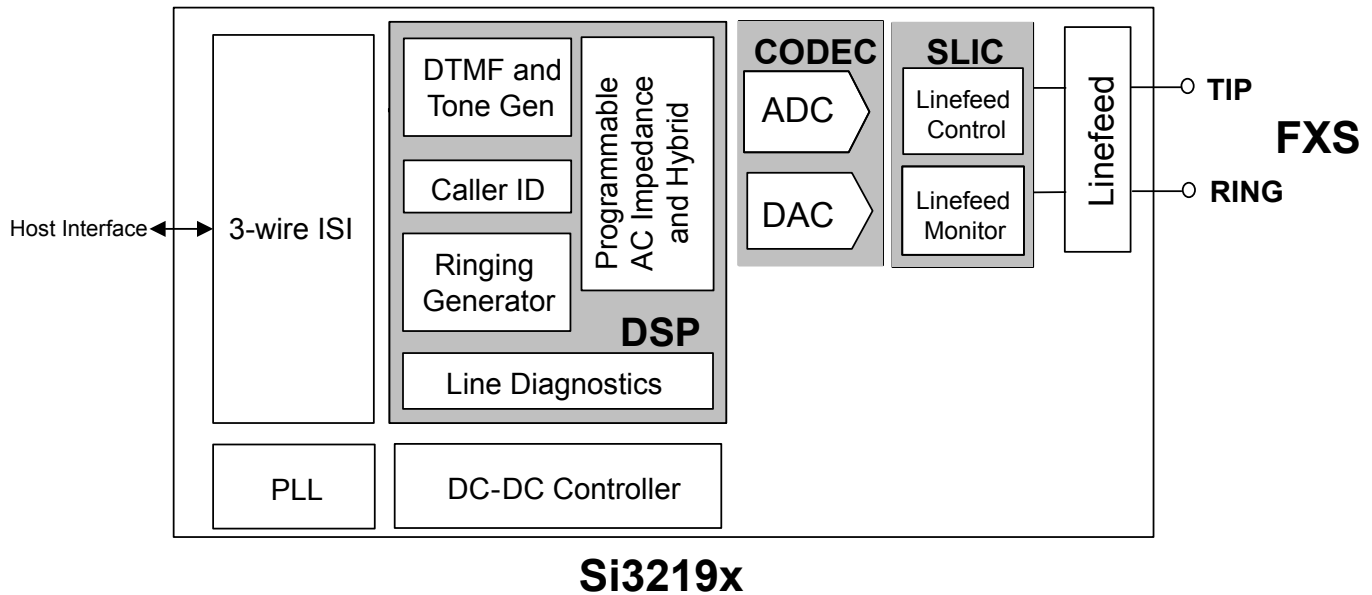

Figure 2.1. Si3219x Functional Block Diagram

The Si3219x series provides all SLIC, codec, DTMF detection, and signal generation functions needed for one complete analog telephone interface. The Si3219x performs all battery, over-voltage, ringing, supervision, codec, hybrid, and test (BORSCHT) functions; it also supports extensive metallic loop and self-test capabilities.

The Si3219x supports wideband audio (150 Hz–6.8 kHz) compliant with PKT-SP-HDV-104-120823, and is configurable to support the full ITU-T-G.722-201209 bandwidth (50 Hz–7 kHz). The wideband mode provides an expanded audio band with a 16 kHz sample rate for enhanced audio quality.

The Si3219x series supports a 3-wire ISI digital interface.

The Si3219x incorporates a programmable dc-dc converter controller that reacts to line conditions to provide the optimal battery voltage required for each line-state. Si3219x ICs are available with voltage ratings of –100 V.

Programmable on-hook voltage, programmable off-hook loop current, reverse polarity operation, loop or ground start operation, and on-hook transmission are supported. Loop current and voltage are continuously monitored by an integrated monitoring ADC.

The Si3219x single ProSLIC devices support ringing with or without a programmable dc offset and can operate in low-power ringing and adaptive-ringing modes. The available voltage offset, frequency, waveshape, and cadence options are designed to ring the widest variety of terminal devices and to reduce external controller requirements.

A complete audio transmit and receive path is integrated, including ac impedance and hybrid gain. These features are software-programmable, allowing a single hardware design to meet global requirements.

3. Electrical Specifications

Table 3.1. Recommended Operating Conditions

Parameter	Symbol	Test Condition	Min	Typ	Max	Unit
Ambient Temperature	T_A	F-grade, Z-grade	0	25	70	°C
		G-grade	-40	25	85	°C
Silicon Junction Temperature, High Voltage Die	T_{JHV}	Continuous	—	—	Internally Limited	°C
Silicon Junction Temperature, Low Voltage Die	T_{JLV}	Continuous	—	—	125	°C
Supply Voltages	V_{DDD}, V_{DDA}		3.13	3.3	3.47	V
Battery Voltage ²	V_{BAT}		-100	—	-15	V
IO Supply Voltage	V_{DDIO}		1.71	—	3.47	V

Note:

1. All minimum and maximum specifications apply across the recommended operating conditions. Typical values apply at nominal supply voltages and an operating temperature of 25 °C unless otherwise stated.
2. Minimum and maximum battery voltage limits are dependent upon loop conditions and dc-dc converter configuration.

Table 3.2. Power Supply Characteristics

Parameter	Symbol	Test Condition	Min	Typ	Max	Unit
Supply Currents:	I_{DD}	V_T and $V_R = \text{Hi-Z}$, $R_{STB} = 0$	—	5.13	—	mA
Reset	I_{VBAT}		—	—	—	mA
Supply Currents:	I_{DD}	V_T and $V_R = \text{Hi-Z}$	—	11.15	—	mA
High Impedance, Open	I_{VBAT}		—	0.6	—	mA
Supply Currents:	I_{DD}	$V_{TR} = -48 \text{ V}$, Automatic Power Save Mode Enabled	—	11.6	—	mA
Forward/Reverse, On-hook	I_{VBAT}		—	0.6	—	mA
Supply Currents:	I_{DD}	$V_{TR} = -48 \text{ V}$, Automatic Power Save Mode Disabled	—	30.44	—	mA
Forward/Reverse, On-hook	I_{VBAT}		—	2.1	—	mA
Supply Currents:	I_{DD}	V_T or $V_R = -48 \text{ V}$ V_R or $V_T = \text{Hi-Z}$, Automatic Power Save Mode Enabled	—	11.5	—	mA
Tip/Ring Open, On-hook	I_{VBAT}		—	0.4	—	mA
Supply Currents:	I_{DD}	V_T or $V_R = -48 \text{ V}$ V_R or $V_T = \text{Hi-Z}$, Automatic Power Save Mode Disabled	—	30.6	—	mA
Tip/Ring Open, On-hook	I_{VBAT}		—	1.3	—	mA
Supply Currents:	I_{DD}	$V_{TR} = 48 \text{ V}$	—	44.7	—	mA
Forward/Reverse OHT, On-hook	I_{VBAT}		—	2.9	—	mA
Supply Currents:	I_{DD}	$I_{LOOP} = 20 \text{ mA}$, $R_{LOAD} = 200 \Omega$	—	44.4	—	mA
Forward/Reverse Active, Off-hook	I_{VBAT}		—	21.65	—	mA
Supply Currents:	I_{DD}	$V_{TR} = 55 V_{RMS} + 0 V_{DC}$, low power ringing, sinusoidal, $f = 20 \text{ Hz}$, $R_{LOAD} = 3 \text{ REN} = 2333 \Omega$	—	33.8	—	mA
Ringing	I_{VBAT}		—	24.4	—	mA

Note:

1. All specifications are for a tracking low-cost capacitive boost dc-dc converter at 25 °C. V_{DDD} , $V_{DDA} = 3.3 \text{ V}$; $V_{DC} = 12 \text{ V}$.
2. I_{DD} includes $I_{DDIO} + I_{DDD} + I_{DDA}$.

Table 3.3. AC Characteristics

Parameter	Test Condition	Min	Typ	Max	Unit
TX/RX Performance					
Overload Compression	2-Wire - PCM	See Figure 3.4 Overload Compression Performance on page 14.	—	—	
Single Frequency Distortion	200 Hz to 3.4 kHz (μ -law/A-law)	—	—	-40	dB
	200 Hz to 3.4 kHz (16-bit linear)	—	—	-63	dB
Signal-to-(Noise + Distortion) Ratio ¹	200 Hz to 3.4 kHz transmit or receive path Active off-hook, and OHT, any Z _T	See Figure 3.3 Transmit and Receive Path SNDR on page 13.	—	—	
Audio Tone Generator Signal-to-Distortion Ratio ¹	0 dBm ₀ , Active off-hook, and OHT, any Z _T	46	—	—	dB
Intermodulation Distortion		—	—	-41	dB
Gain Accuracy ¹	2-Wire to PCM or PCM to 2-Wire 1014 Hz, Any gain setting	-0.2	—	0.2	dB
Attenuation Distortion vs. Frequency	0 dBm 0 ⁵	See Figure 3.5 Receive Path Frequency Response on page 14 and Figure 3.6 Transmit Path Frequency Response on page 15.			
Group Delay vs. Frequency		See Figure 3.7 Transmit Group Delay Distortion on page 15 and Figure 3.8 Receive Group Delay Distortion on page 16.			
Gain Tracking ²	1014 Hz sine wave, reference level -10 dBm, Signal level:	—	—	—	—
	3 dB to -37 dB	—	—	0.25	dB
	-37 dB to -50 dB	—	—	0.5	dB
	-50 dB to -60 dB	—	—	1.0	dB
Round-Trip Group Delay	1014 Hz, Within same time-slot	—	450	500	μ s
2-Wire Return Loss ³	200 Hz to 3.4 kHz	26	30	—	dB
Transhybrid Balance ³	300 Hz to 3.4 kHz	26	30	—	dB
Noise Performance					
Idle Channel Noise ⁴	C-Message weighted	—	8	14	dBrnC
	Psophometric weighted	—	-82	-76	dBmP
PSRR from V _{DD} , V _{DDIO} @ 3.3 V	RX and TX, 200 Hz to 3.4 kHz	—	55	—	dB
Longitudinal Performance					

Parameter	Test Condition	Min	Typ	Max	Unit
Longitudinal to Metallic/PCM Balance (forward or reverse)	200 Hz to 1 kHz	—	60	—	dB
	1 kHz to 3.4 kHz	—	58	—	dB
Metallic/PCM to Longitudinal Balance	200 Hz to 3.4 kHz	—	—	—	dB
Longitudinal Impedance	200 Hz to 3.4 kHz at TIP or RING	—	50	—	Ω
Longitudinal Current Capability	Active off-hook 60 Hz Reg 73 = 0x0B	—	25	—	mA

Note:

1. Analog signal measured as $V_{TIP} - V_{RING}$. Assumes ideal line impedance matching.
2. The quantization errors inherent in the μ/A -law companding process can generate slightly worse gain tracking performance in the signal range of 3 to -37 dB for signal frequencies that are integer divisors of the 8 kHz PCM sampling rate.
3. $V_{DD} = 3.3$ V, $V_{BAT} = -52$ V, no fuse resistors; $R_L = 600 \Omega$, $Z_S = 600 \Omega$ synthesized using RS register coefficients.
4. The level of any unwanted tones within the bandwidth of 0 to 4 kHz does not exceed -55 dBm.
5. 0 dBm 0 is equal to 0 dBm into 600Ω .

Table 3.4. Linefeed Characteristics

Parameter	Symbol	Test Condition	Min	Typ	Max	Unit
DC Feed Current		Differential	—	—	45	mA
		Common Mode	—	—	30	mA
		Differential + Common Mode	—	—	45	mA
DC Loop Current Accuracy		$I_{LIM} = 18 \text{ mA}$	—	—	10	%
DC Open Circuit Voltage Accuracy		Active Mode; $V_{OC} = 48 \text{ V}$, $V_{TIP} - V_{RING}$	—	—	4	V
DC Differential Output Resistance	R_{DO}	$I_{LOOP} < I_{LIM}$	160	—	640	Ω
DC On-Hook Voltage Accuracy-Ground Start (TIP Open)	V_{OHTO}	$I_{RING} < I_{LIM}$; V_{RING} wrt ground, $V_{RING} = -51 \text{ V}$	—	—	4	V
DC Output Resistance-Ground Start (TIP Open)	R_{ROTO}	$I_{RING} < I_{LIM}$; RING to ground	160	—	640	Ω
DC Output Resistance-Ground Start (TIP Open)	R_{TOTO}	TIP to ground	400	—	—	k Ω
Loop Closure Detect Threshold Accuracy		$I_{THR} = 13 \text{ mA}$	—	—	10	%
Ground Key Detect Threshold Accuracy		$I_{THR} = 13 \text{ mA}$	—	—	10	%
Ring Trip Threshold Accuracy		AC detection, $V_{RING} = 70 \text{ Vpk}$, no offset, $I_{TH} = 80 \text{ mA}$	—	—	4	mA
		DC detection, 20 V dc offset, $I_{TH} = 13 \text{ mA}$	—	—	1	mA
Ringing Amplitude	$V_{RINGING}$	Open circuit, $V_{BAT} = -100 \text{ V}$	-100	—	—	V_{PK}
Sinusoidal Ringing Total Harmonic Distortion	R_{THD}	50 V_{RMS} , 0 V_{OFFSET} , 0–5 REN	—	1	—	%
Ringing Frequency Accuracy		$f = 16 \text{ Hz to } 60 \text{ Hz}$	—	—	1	%
Ringing Cadence Accuracy		Accuracy of ON/OFF times	—	—	50	ms
Loop Voltage Sense Accuracy		$V_{TIP} - V_{RING} = 48 \text{ V}$	—	2	4	%
Loop Current Sense Accuracy		$I_{LOOP} = 18 \text{ mA}$	—	7	10	%

Table 3.5. Digital I/O Characteristics

Parameter	Symbol	Test Condition	Min	Typ	Max	Unit
High-Level Input Voltage	V_{IH}	PSCLK, RSTB, ISI_MOSI	$0.7 \times V_{DDIO}$	—	V_{DDIO}	V
Low-Level Input Voltage	V_{IL}	PSCLK, RSTB, ISI_MOSI	—	—	$0.3 \times V_{DDIO}$	V
High-Level Output Voltage	V_{OH}	ISI_MISO, $I_O = -4 \text{ mA}$	$V_{DDIO} - 0.6$	—	—	V
Low-Level Output Voltage	V_{OL}	ISI_MISO, $I_O = 4 \text{ mA}$	—	—	0.4	V
Input Leakage Current	I_L		—	—	10	μA

Table 3.6. Charge Pump Characteristics

Parameter	Symbol	Test Condition	Min	Typ	Max	Unit
Output Voltage (DCDRV, DCFF)	V_{CP}		$2 \times V_{DD} - 1$	—	$2 \times V_{DD}$	V
Output Current	I_{CP}		—	—	3 ¹	mA

Note:

1. Peak drive current capability is >60 mA.

Table 3.7. Switching Characteristics (General Inputs)

Parameter	Symbol	Min	Typ	Max	Unit
RSTB Pulse Width	t_{RST}	200	—	—	μ s
RSTB High to First Register/RAM Access	t_{RCS}	5	—	—	ms

Note:

1. All timing is referenced to the 50% level of the waveform. Input test levels are $V_{IH} = V_{DDIO} - 0.4$ V, $V_{IL} = 0.4$ V. Rise and Fall times are referenced to the 20% and 80% levels of the waveform.
2. MSIF_LOCK signal on SoC must be active before valid SPI communication.

**Figure 3.1. Si3219x Reset Timing Diagram**

Table 3.8. Switching Characteristics (ISI)

Parameter	Symbol	Min	Typ	Max	Unit
Setup Time, ISI_MOSI to PSCLK Fall	t_{su}	7.5	—	—	ns
Hold Time, ISI_MOSI to PSCLK Fall	t_h	5	—	—	ns
Delay Time, PSCLK Rise to ISI_MISO	t_d	—	—	16	ns
PSCLK Period	t_p	—	40.69	—	ns
PSCLK Duty Cycle		40	50	60	%

Note:

1. Timing should be guaranteed by ISI-enabled host SoC.

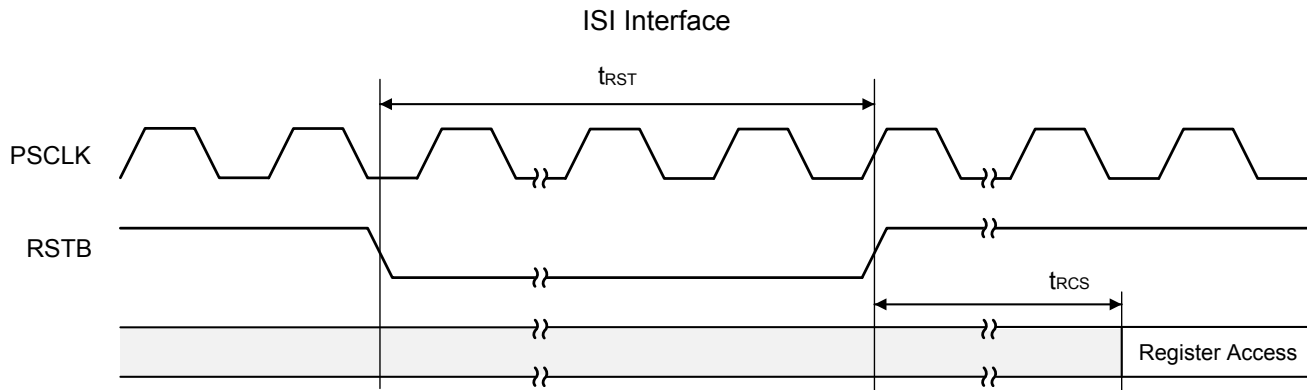
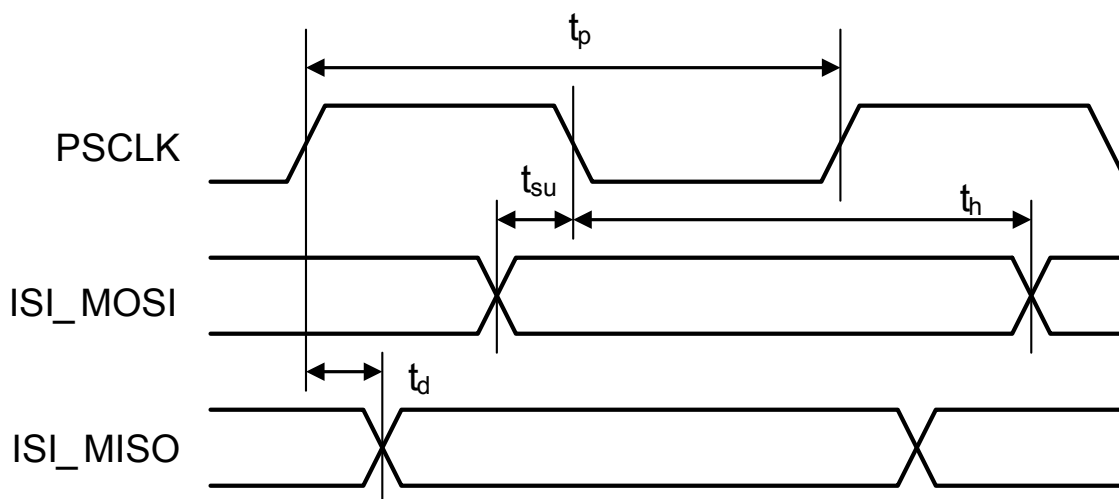
**Figure 3.2. ISI Timing Diagram****Table 3.9. Thermal Conditions**

Parameter	Symbol	Test Condition	Value	Unit
Storage Temperature Range	T_{STG}		-55 to 150	°C
Thermal Resistance, Typical QFN-38 ¹	θ_{JA}		35	°C/W
	θ_{JC}		15	°C/W
Maximum Junction Temperature, (High Voltage Die) ³	T_{JHV}	Continuous	Internally Limited	°C
Maximum Junction Temperature (Low Voltage Die) ²	T_{JLV}		125	°C

Note:

1. The thermal resistance of an exposed pad package is assured when the recommended printed circuit board layout guidelines are followed correctly. The specified performance requires that the exposed pad be soldered to an exposed copper surface of at least equal size and that multiple vias are added to enable heat transfer between the top-side copper surface and a large internal/bottom copper plane. Thermal resistance values are empirical measurements taken from 2-Layer EVBs.
2. Operation of the Si3219x above 125 °C junction temperature may degrade device reliability.
3. Si3219x linefeed is equipped with on-chip thermal limiting circuitry that shuts down the circuit when the junction temperature exceeds the thermal shutdown threshold. The thermal shutdown threshold is normally set to 145 °C; when in the ringing state the thermal shutdown is set to 200 °C.

Table 3.10. Absolute Maximum Ratings

Parameter	Symbol	Value	Unit
Supply Voltage	V_{DD}, V_{DDIO}	-0.5 to 4.0	V
Digital Input Voltage	V_{IND}	-0.3 to $V_{DDIO} + 0.5$	V
Battery Supply Voltage	V_{BAT}	+0.4 to 102	V
Tip or Ring Voltage	V_{TIP}, V_{RING}	$V_{BAT} - 0.4$	V
TIP, RING Current	I_{TIP}, I_{RING}	± 100	mA

Note:

- Permanent device damage may occur or the reliability of the device may be affected if the device is operated at or above the absolute maximum ratings.

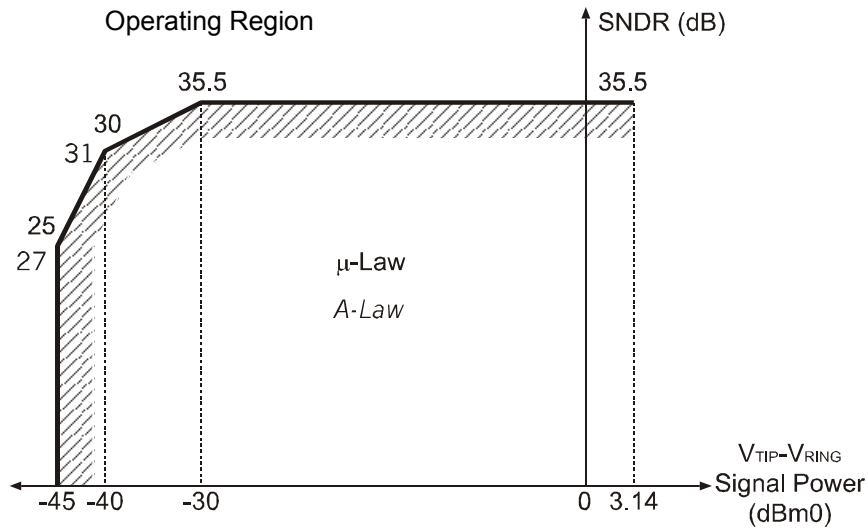

Figure 3.3. Transmit and Receive Path SNDR

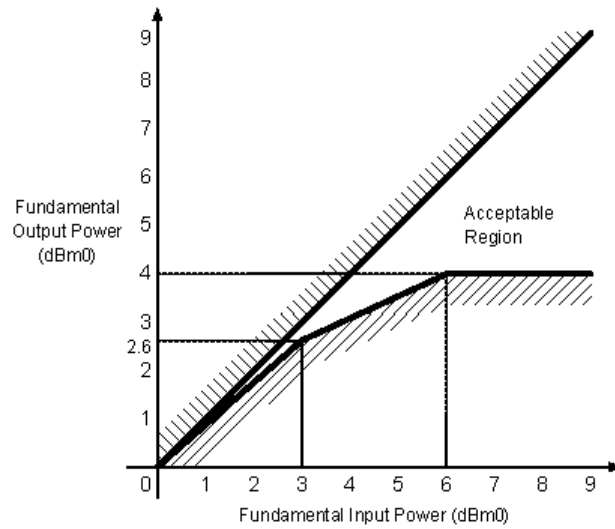

Figure 3.4. Overload Compression Performance

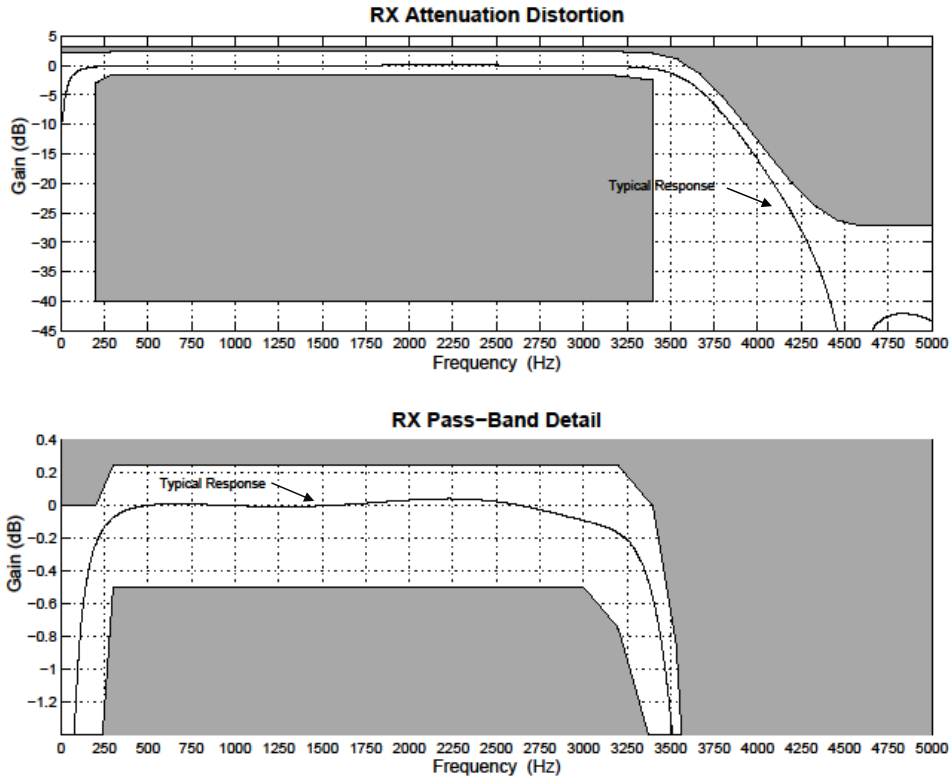

Figure 3.5. Receive Path Frequency Response

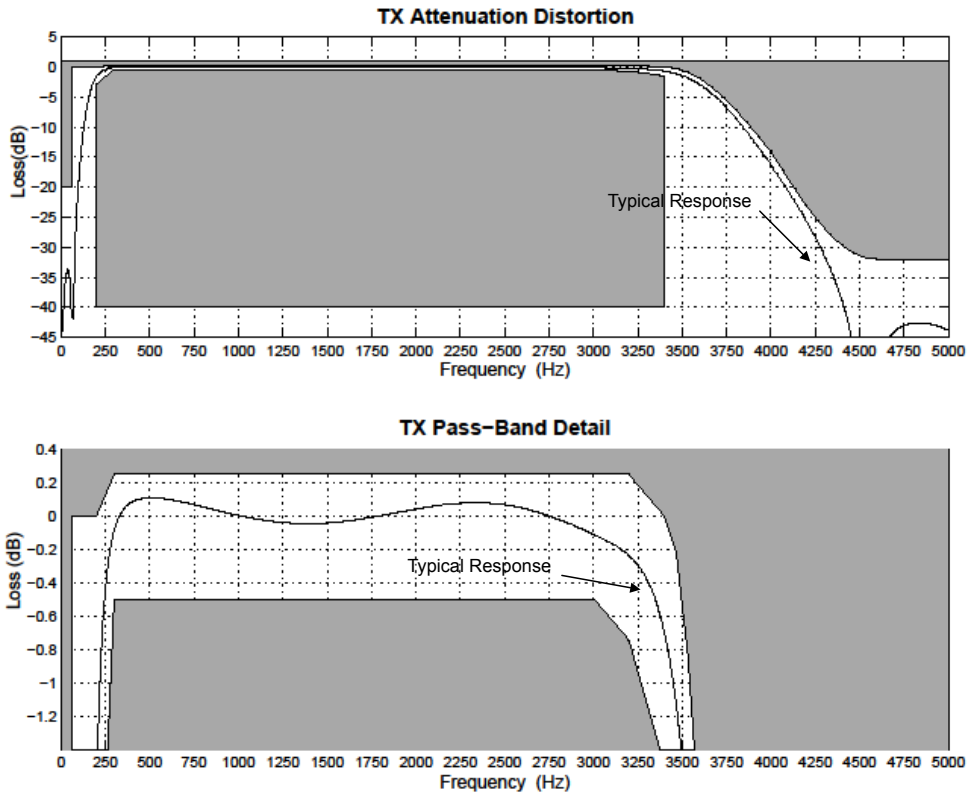

Figure 3.6. Transmit Path Frequency Response

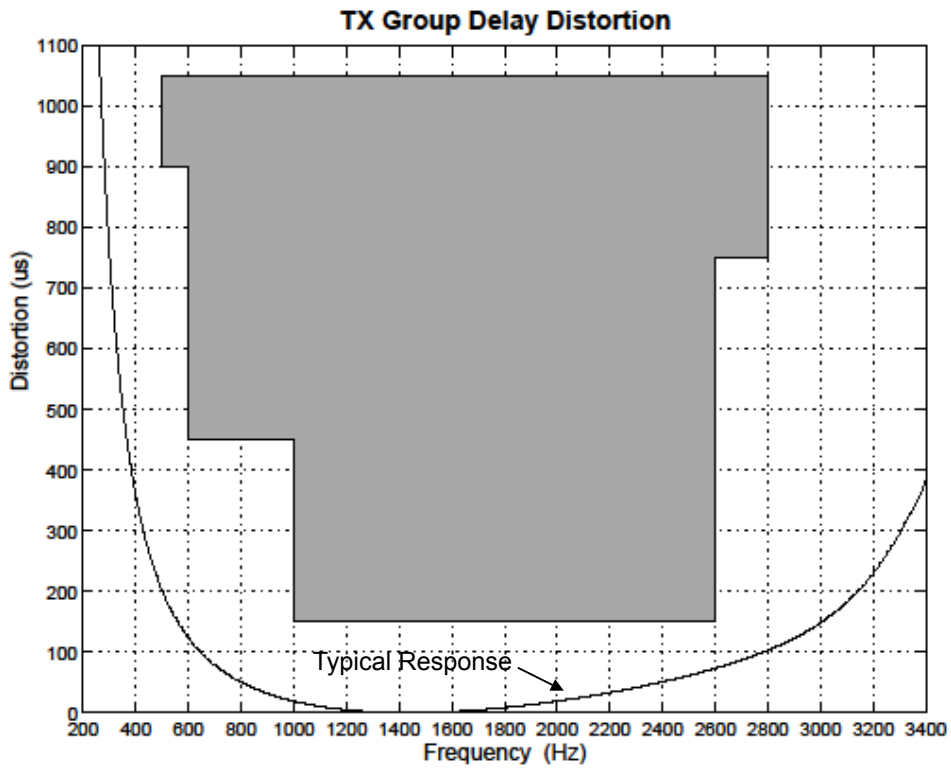

Figure 3.7. Transmit Group Delay Distortion

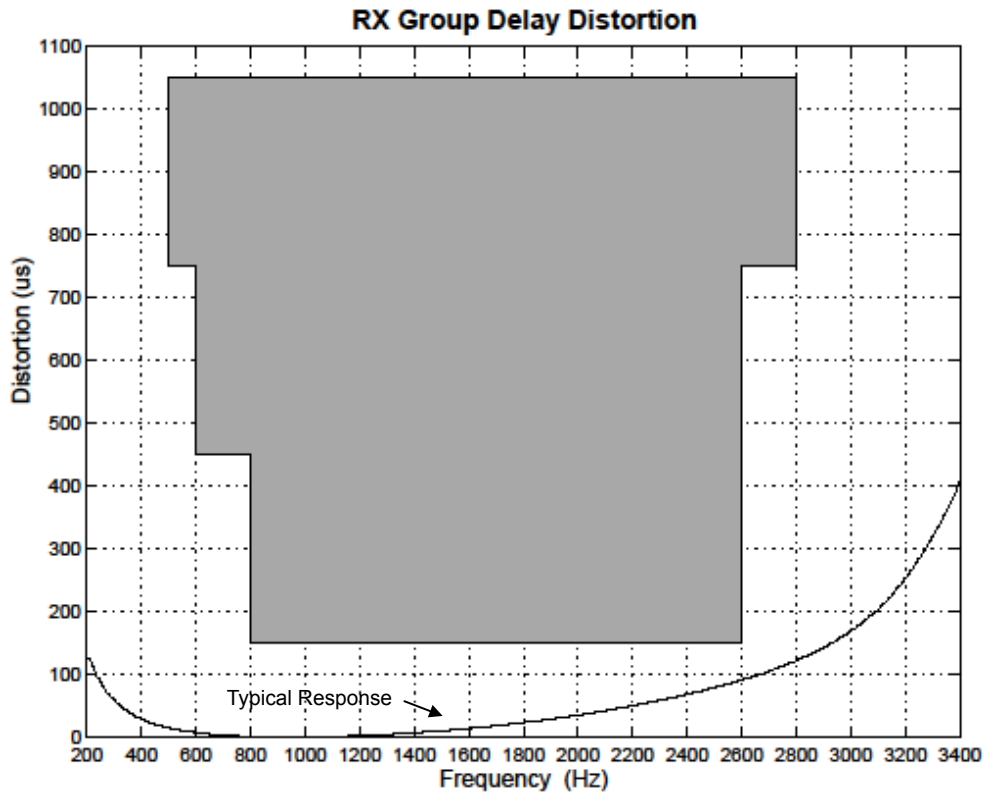

Figure 3.8. Receive Group Delay Distortion

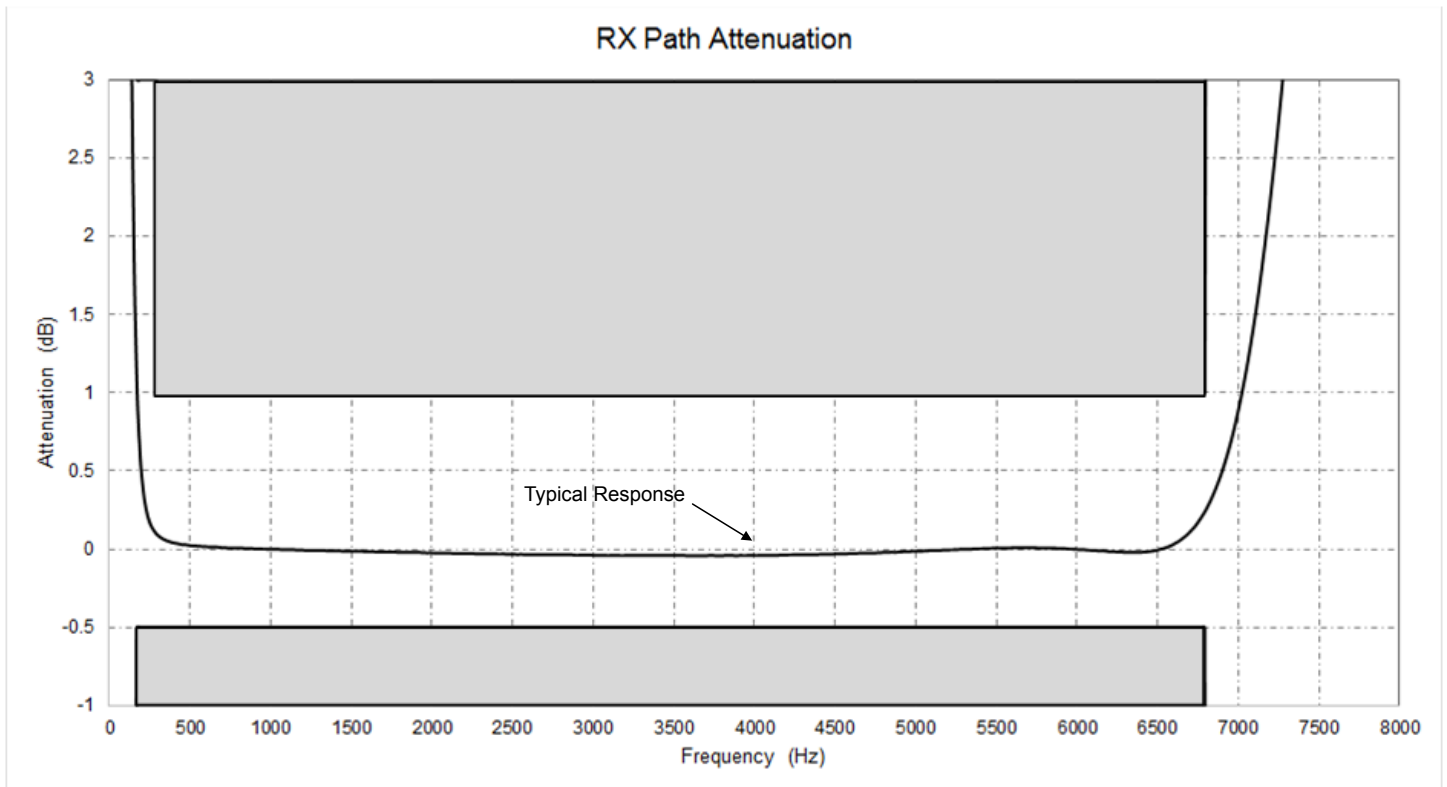

Figure 3.9. Receive Wideband Frequency Response

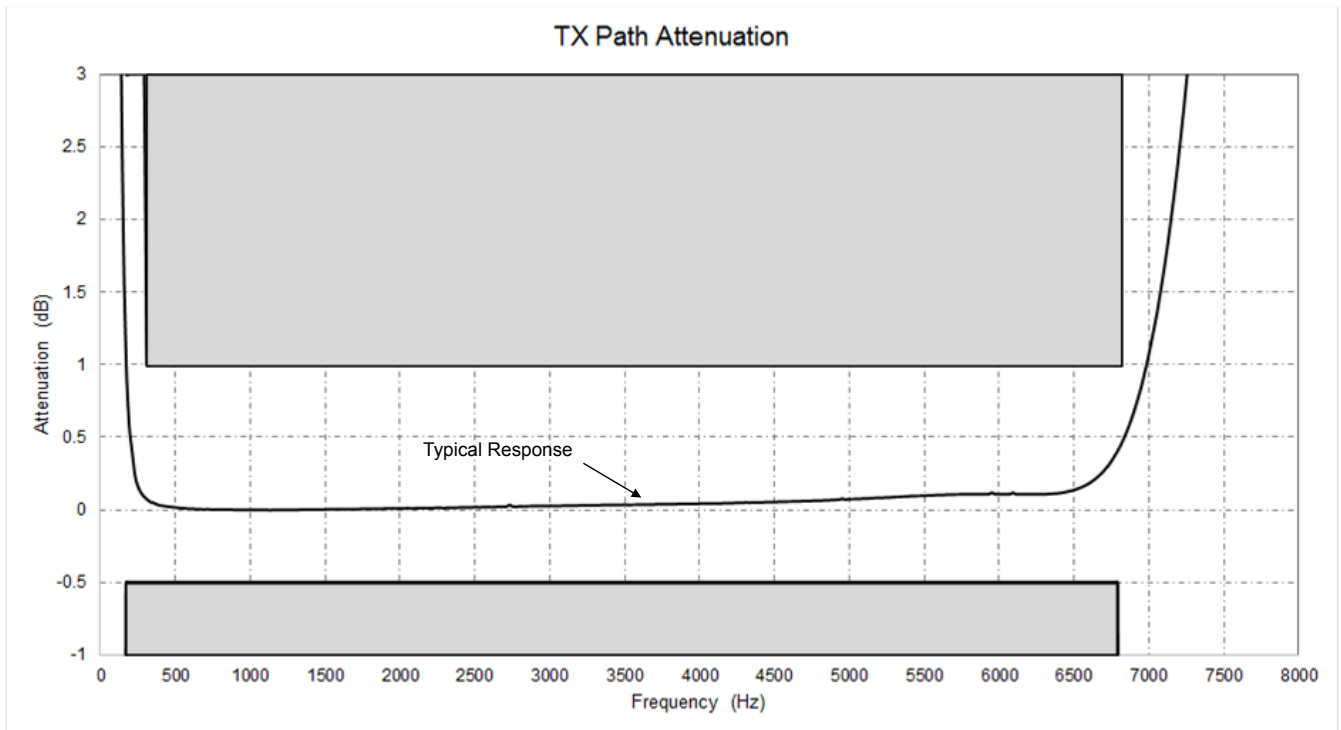

Figure 3.10. Transmit Wideband Frequency Response

4. FXS Features

4.1 DC Feed Characteristics

ProSLIC internal linefeed circuitry provides completely programmable dc feed characteristics.

When in the active state, the ProSLIC operates in one of three dc linefeed operating regions: a constant-voltage region, a constant-current region, or a resistive region, as shown in the figure below. The constant-voltage region has a low resistance, typically 160 Ω . The constant-current region approximates infinite resistance.

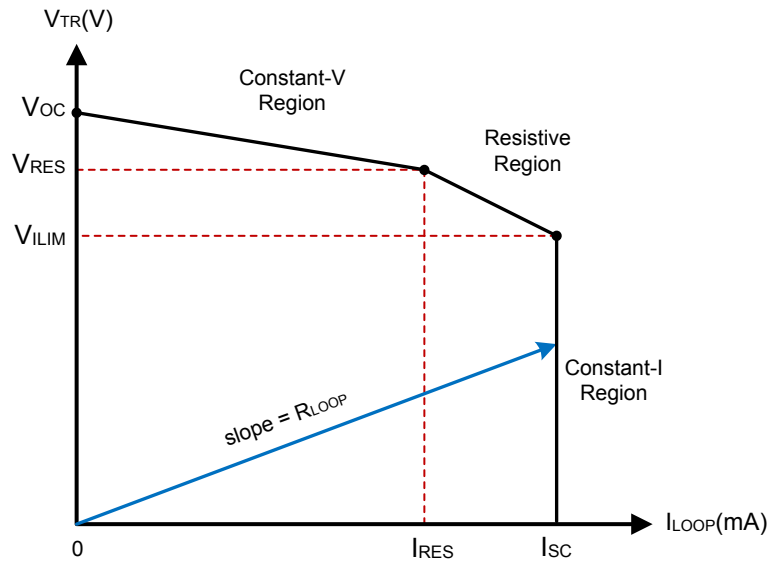

Figure 4.1. Dual ProSLIC DC Feed Characteristics

4.2 Linefeed Operation States

The linefeed interface includes eight different register-programmable operating states as listed in [Table 4.1 Linefeed Operating States on page 19](#). The Open state is the default condition in the absence of any preloaded register settings. The device may also automatically enter the open state in the event of a linefeed fault condition.

4.3 Line Voltage and Current Monitoring

The ProSLIC continuously monitors the TIP, RING, and battery voltages and currents via an on-chip Monitor ADC and stores the resulting values in individual RAM locations. Additionally, VTIP, VRING, loop current, and longitudinal current values are calculated based on the differential and common mode voltage measurements. The ADC updates all registers at a rate of 2 kHz or greater.

4.4 Power Monitoring and Power Fault Detection

The Si3219x line monitoring functions are used to continuously protect against excessive power conditions.

If the Si3219x detects an overpower condition, it automatically sets that device to the open state and generates a "power alarm" interrupt.

The interrupt can be masked, but masking the automatic transition to open is not recommended since it is used to protect the Si3219x HVIC under excessive power conditions.

4.5 Thermal Overload Shutdown

If the die temperature exceeds the maximum junction temperature threshold, T_{Jmax} , of 145 °C or 200 °C (depending on the operating state), the device has the ability to shut itself down to a low-power state without user intervention. A thermal alarm interrupt is generated to notify host that the device has been switched to open state.

Table 4.1. Linefeed Operating States

Linefeed State	Description
Open	Output is high-impedance and audio is not transmitted. This is the default state after powerup or following a hardware reset. This state can also be used in the presence of line fault conditions and to generate open switch intervals (OSIs). This state is used in line diagnostics mode as a high impedance state during linefeed testing. A power fault condition may also force the device into the open state.
Forward Active Reverse Active	Linefeed circuitry and audio are active. In Forward Active state, the TIP lead is more positive than the RING lead; in Reverse Active state, the RING lead is more positive than the TIP lead.
Forward OHT Reverse OHT	Provides data transmission during an on-hook loop condition (e.g., transmitting caller ID data between ringing bursts). Linefeed circuitry and audio are active. In Forward OHT state, the TIP lead is more positive than the RING lead; in Reverse OHT state, the RING lead is more positive than the TIP lead.
TIP Open	Provides an active linefeed on the RING lead and sets the TIP lead to high impedance ($\geq 400\text{ k}\Omega$) for ground start operation in forward polarity. Loop closure and ground key detect circuitry are active.
RING Open	Provides an active linefeed on the TIP lead and sets the RING lead to high impedance ($\geq 400\text{ k}\Omega$) for ground start operation in reverse polarity. Loop closure and ground key detect circuitry are active.
Ringing	Drives programmable ringing signal onto TIP and RING leads with or without dc offset.

4.6 Loop Closure Detection

The Si3219x provides a completely programmable loop closure detection mechanism. The loop closure detection scheme provides two unique thresholds to allow hysteresis, and also includes a programmable debounce filter to eliminate false detection. A loop closure detect status bit provides continuous status, and a maskable interrupt bit is also provided.

4.7 Ground Key Detection

The Si3219x provides a ground key detect mechanism using a programmable architecture similar to the loop closure scheme. The ground key detect scheme provides two unique thresholds to allow hysteresis and also includes a programmable debounce filter to eliminate false detection. A ground key detect status bit provides continuous status, and a maskable interrupt bit is also provided.

4.8 Ringing Generation

The Si3219x supports the patented Low-Power Ringing (LPR) method exclusively, which when used with a tracking battery scheme, maximizes the ringing power transferred to the load and reduces overall power consumption. Ringing is fully programmable including frequency, amplitude, dc offset, wave shape and crest factor. The Si3219x also supports automatic ring cadencing and ringtrip detection (AC and DC).

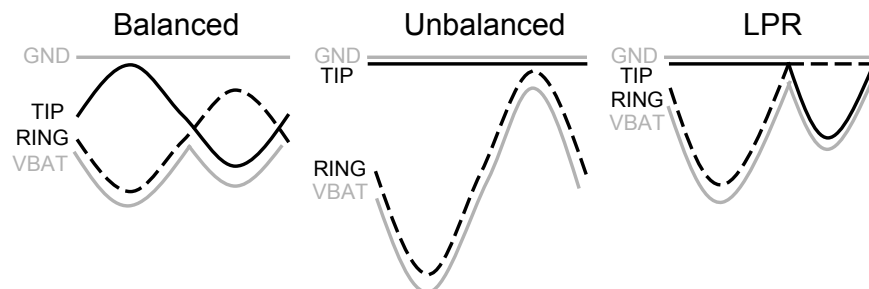

Figure 4.2. Ringing Mode

4.9 Polarity Reversal

The Si3219x supports polarity reversal for message waiting and various other signaling modes. The ramp rate can be programmed for a smooth or abrupt transition to accommodate different application requirements.

4.10 Two-wire Impedance Synthesis

The ac two-wire impedance synthesis is generated on-chip using a DSP-based scheme to optimally match the output impedance of the Si3219x to the reference impedance. Most real or complex two-wire impedances can be generated with appropriate register coefficients.

4.11 Transhybrid Balance Figure

The trans-hybrid balance function is implemented on-chip using a DSP-based scheme to effectively cancel the reflected receive path signal from the transmit path.

4.12 Tone Generators

The Si3219x includes two digital tone generators that allow a wide variety of single- or dual-tone frequency and amplitude combinations. Each tone generator has its own set of registers that hold the desired frequency, amplitude, and cadence to allow generation of DTMF and call progress tones for different requirements. The tones can be directed to either receive or transmit paths.

4.13 DTMF Detection (Si32193 Only)

In DTMF, two tones generate a DTMF digit. One tone is chosen from four possible row tones, and one tone is chosen from four possible column tones. The sum of these tones constitutes one of 16 possible DTMF digits.

4.14 Pulse Metering

The pulse metering system for the Si3219x is designed to inject a 12 or 16 kHz billing tone into the audio path with maximum amplitude of 0.85 VRMS at TIP and RING into a 200 Ω ac load impedance. The tone is generated in the DSP via a table lookup that guarantees spectral purity by not allowing drift. The tone will ramp up until it reaches a host-programmed threshold, at which point it will maintain that level until instructed to ramp down, thus creating a trapezoidal envelope.

The amplitude is controlled by an automatic gain control circuit (AGC). While the tone is ramping up, the AGC takes the feedback audio and applies it to a band pass filter, which is programmed for the 12 or 16 kHz frequency of interest. When the peak is detected, the ramp is stopped.

4.15 DC-DC Controller

The Si3219x-C devices integrate a dc-dc controller to control an external tracking dc-dc converter which generates the high voltage supply (VBAT) to the SLIC. The tracking VBAT voltage generated from a single positive dc input is optimized to minimize power consumption by closely tracking the SLIC state, even tracking the ringing waveforms.

The dc-dc controller output DCDRV is driven by an internal charge pump which allows it to connect directly to the gate of the MOSFET switch of the dc-dc converter. This eliminates the need for the MOSFET predrive circuit that is typically required when other SLICs are used with a MOSFET with VTH greater than V_{DD}. See [Table 3.6 Charge Pump Characteristics on page 11](#).

4.16 Wideband Audio

The Si3219x supports wideband audio (150 Hz–6.8 kHz) compliant with PKT-SP-HDV-104-120823, and is configurable to support the full ITU-T-G.722-201209 bandwidth (50 Hz–7 kHz). The wideband provides an expanded audio band at a 16-bit, 16 kHz sample rate for enhanced audio quality while maintaining standard telephony audio compatibility. Wideband audio samples are transmitted and received at an effective 16 kHz rate by using multiple timeslots in a single 8 kHz frame.

4.17 Test Facilities

The Si3219x supports a rich set of metallic loop tests to diagnose external faults, as well as a set of inward self-tests to support diagnostics of the Si3219x-based voice port. Implementation of metallic loop tests required the ProSLIC® MLT API, while the inward self-tests are included in the standard ProSLIC® API.

Table 4.2. Supported Tests

Test	Description
Metallic Loop Tests	
Voltages	Measures ac and dc voltages from T-R, T-G, and R-G.
Receiver Off-hook	Discriminates between resistive fault and off-hook terminating device.
REN	Measures Ringer Equivalence Number (REN).
REN Capacitance	Measures T-R capacitance of on-hook load.
Capacitance	Measures 3-Terminal Capacitance.
Resistance	Measures resistance from T-R, T-G, or R-G.
Inward Self-Tests	
PCM Loopback	Configures Si3219x for 8- or 16-bit PCM loopback.
DC Feed	Verify dc Feed I/V and loop closure using integrated test load.
Ring and Ringtrip	Verify ringing voltage (ac and dc). Optional ringtrip check to support system level signaling verification.
Battery	Verify VBAT.
Audio Gain	Measure gain of RX (host to line) and TX (line to host) paths without using an external load, test equipment, or requiring the host to provide audio samples.

In addition to these specific test suites, the user is free to use the general test facilities listed in the following table:

Table 4.3. General Test Facilities

Test	Description
Monitor ADC	Provides TIP/RING voltages (inside and outside overcurrent protection), TIP/RING currents and VBAT voltage.
Audio Diagnostic Filters	Three cascaded second-order Biquad filters with peak hold and averaging capabilities.
Loopback Modes	Digital and analog loopback modes to isolate portions of the audio path.
Tone Generators	The dual-tone generators may be used as general-purpose test signal generators.

5. System Interfaces

5.1 Integrated Serial Interface

The ISI interface supported on select Si3219x devices is a three-wire proprietary interface which serializes SPI and PCM communications and interrupts, reducing the SoC interface from nine wires to three (PSClk, ISI_MISO, ISI_MOSI). SPI communications and PCM data transfers are embedded in the serial data. The host side of the ISI is integrated onto selected SoCs from several vendors.

ISI is a point to point interface; therefore, it is not possible to daisy-chain more than one ISI ProSLIC device.

Both μ -255 Law (μ -Law) and A-law companding formats are supported in addition to 16-bit linear data mode with no companding.

5.2 Input/Output Voltage Selection

The digital host interface I/O (ISI) on the Si3219x may directly interface to 1.8 V to 3.3 V devices. The I/O voltage selection is made by supplying the VDDIO pin with the appropriate I/O supply voltage.

To avoid power supply sequencing issues, VDDIO should be connected to the same supply as VDD in 3.3 V interface designs. Other voltages between 1.8 V and 3.3 V can also be used for VDDIO (for example 2.5 V), but steps must be taken to ensure that the VDDIO supply comes up after the VDD supply if VDDIO is not connected to VDD.

6. Pin Descriptions

6.1 Pin Descriptions: 38 Pin QFN (Si32192/3)

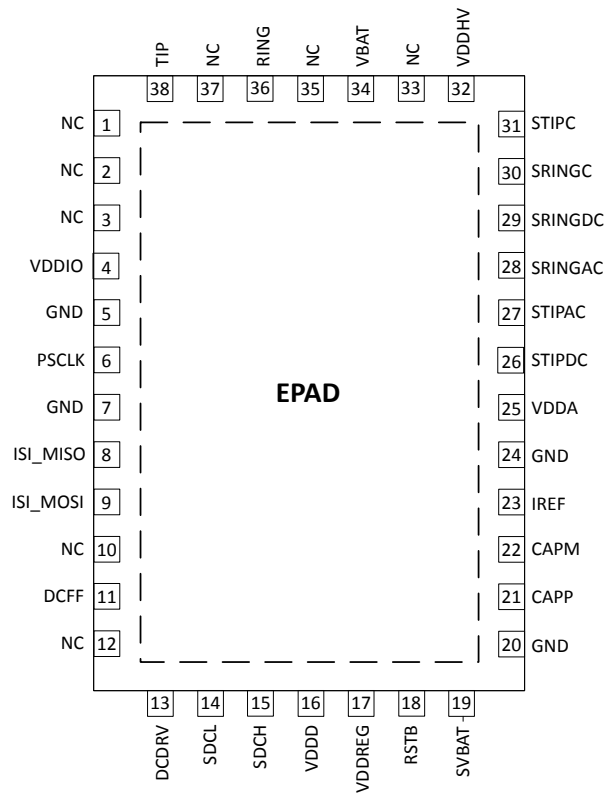

Table 6.1. Si3219x Pin Descriptions

Pin #	Pin Name	Description
1	NC	No connection. This pin should be left unconnected.
2	NC	No connection. This pin should be left unconnected.
3	NC	No connection. This pin should be left unconnected.
4	VDDIO	Digital IO Supply Voltage. 3.3 V or 1.8 V digital power supply for internal circuitry.
5	GND	Ground. Connect to ground.
6	PSCLK	ISI Bus Clock Input. Clock input for ISI bus timing.
7	GND	Ground. Connect to ground.

Pin #	Pin Name	Description
8	ISI_MISO	Transmit ISI Output. ISI Master Input, Slave Output. Output data to ISI bus.
9	ISI_MOSI	Transmit ISI Input. ISI Master Output, Slave input. Input data from ISI bus.
10	NC	No connection. This pin should be left unconnected.
11	DCFF	DC-DC Charge Pump Output.
12	NC	No connection. This pin should be left unconnected.
13	DCDRV	DC Drive. DC-DC converter control signal output which drives external transistor.
14	SDCL	DC Monitor. DC-DC converter monitor input used to detect overcurrent situations in the converter.
15	SDCH	DC Monitor. DC-DC converter monitor input used to detect overcurrent situations in the converter.
16	VDDD	IC Voltage Supply. 3.3 V digital power supply for internal circuitry.
17	VDDREG	Regulated Core Power Supply.
18	RSTB	Reset Input. Active low input. Hardware reset used to place all control registers in the default state.
19	SVBAT	VBAT Sense. Input used to sense voltage on DC-DC converter output voltage lead.
20	GND	Ground. Connect to ground.
21	CAPP	SLIC Stabilization Capacitor. Capacitor used in dc feed low-pass filter.
22	CAPM	SLIC Stabilization Capacitor. Capacitor used in dc feed low-pass filter.
23	IREF	Current Reference Input. Connects to an external resistor used to provide a high accuracy reference current.
24	GND	Ground. Connect to ground.
25	VDDA	Analog Supply Voltage. Analog 3.3 V power supply for internal analog circuitry.
26	STIPDC	TIP DC Sense. Analog DC input used to sense voltage on TIP lead.

Pin #	Pin Name	Description
27	STIPAC	TIP AC Sense. Analog AC input used to sense voltage on TIP lead.
28	SRINGAC	RING AC Sense. Analog AC input used to sense voltage on RING lead.
29	SRINGDC	RING DC Sense. Analog DC input used to sense voltage on RING lead.
30	SRINGC	RING Coarse Sense Input. Voltage sensing outside protection circuit.
31	STIPC	TIP Coarse Sense Input. Voltage sensing outside protection circuit.
32	VDDHV	Analog Supply Voltage. Analog 3.3 V power supply for internal analog circuitry.
33	NC	No connection. This pin should be left unconnected.
34	VBAT	Battery Voltage Supply. Connect to battery supply from DC-DC converter.
35	NC	No connection. This pin should be left unconnected.
36	RING	RING Terminal. Connect to the RING lead of the subscriber loop.
37	NC	No connection. This pin should be left unconnected.
38	TIP	TIP Terminal. Connect to the TIP lead of the subscriber loop.
—	EPAD	Exposed paddle. Connect to ground.

7. Package Outline

7.1 Package Outline: 38-Pin QFN

The figure below illustrates the package details for the Si3219x in a 38-pin QFN package. The table below lists the values for the dimensions shown in the illustration.

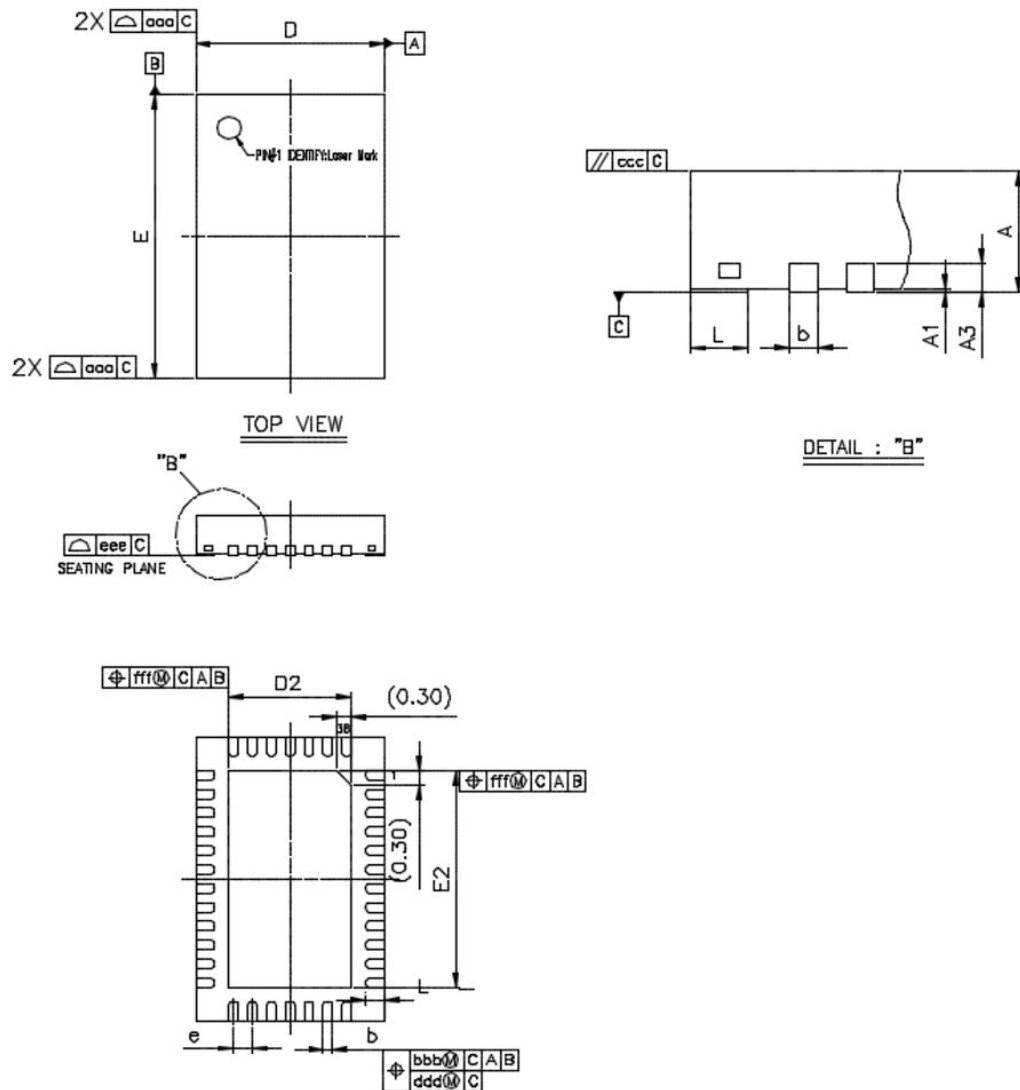

Figure 7.1. 38-Pin QFN Package

Table 7.1. Package Dimensions

Dimension	Min	Nom	Max
A	0.80	0.85	0.90
A1	0.00	0.02	0.05
A3	0.20REF		
b	0.18	0.20	0.25
D	3.90	4.00	4.10
D2	2.50	2.60	2.70
e	0.40 BSC.		
E	5.90	6.00	6.10
E2	4.50	4.60	4.70
L	0.30	0.40	0.50
aaa	—	—	0.10
bbb	—	—	0.07
ccc	—	—	0.10
ddd	—	—	0.05
eee	—	—	0.08
fff	—	—	0.10

Note:

1. All dimensions shown are in millimeters (mm) unless otherwise noted.
2. Dimensioning and Tolerancing per ANSI Y14.5M-1982.
3. Recommended card reflow profile is per the JEDEC/IPC J-STD-020 specification for Small Body Components.

8. Land Pattern

8.1 Land Pattern: 38-Pin QFN

The figure below shows the recommended land pattern details for the 38-Pin QFN package. The table below lists the values for the dimensions shown in the illustration.

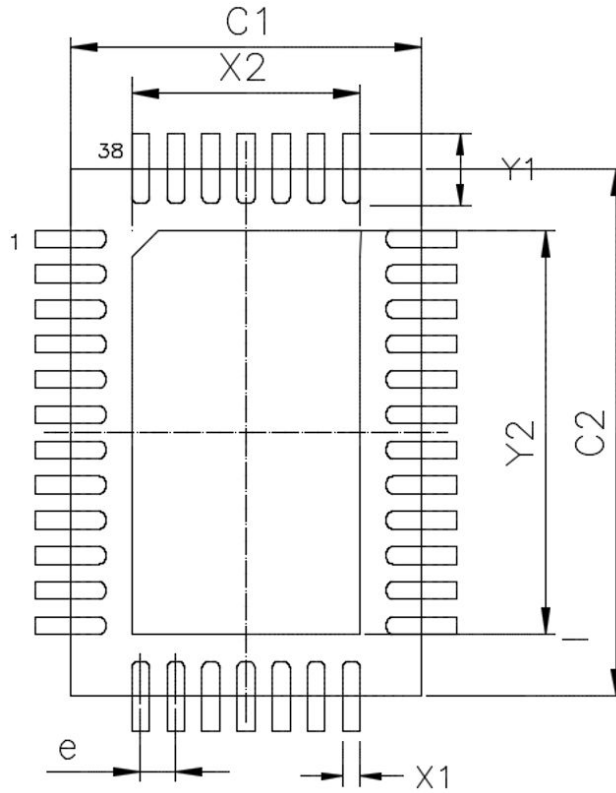

Figure 8.1. 38-Pin QFN Land Pattern

Table 8.1. PCB Land Pattern

Dimension	mm
C1	4.00
C2	6.00
e	0.40
X1	0.20
Y1	0.80
X2	2.70
Y2	4.70

Note:**General**

1. All dimensions shown are at Maximum Material Condition (MMC). Least Material Condition (LMC) is calculated based on a Fabrication Allowance of 0.05mm.
2. This Land Pattern Design is based on the IPC-7351 guidelines.

Solder Mask Design

1. All metal pads are to be non-solder mask defined (NSMD). Clearance between the solder mask and the metal pad is to be 60 μm minimum, all the way around the pad.

Stencil Design

1. A stainless steel, laser-cut and electro-polished stencil with trapezoidal walls should be used to assure good solder paste release.
2. The stencil thickness should be 0.125mm (5 mils).
3. The ratio of stencil aperture to land pad size should be 1:1 for all perimeter pins.
4. A 4x3 array of 0.85 mm square openings on 1.2 mm pitch should be used for the center ground pad to achieve a target solder coverage of ~50%.

Card Assembly

1. A No-Clean, Type-3 solder paste is recommended.
2. The recommended card reflow profile is per the JEDEC/IPC J-STD-020 specification for Small Body Components.

9. Top Marking

9.1 Top Marking 38-pin QFN

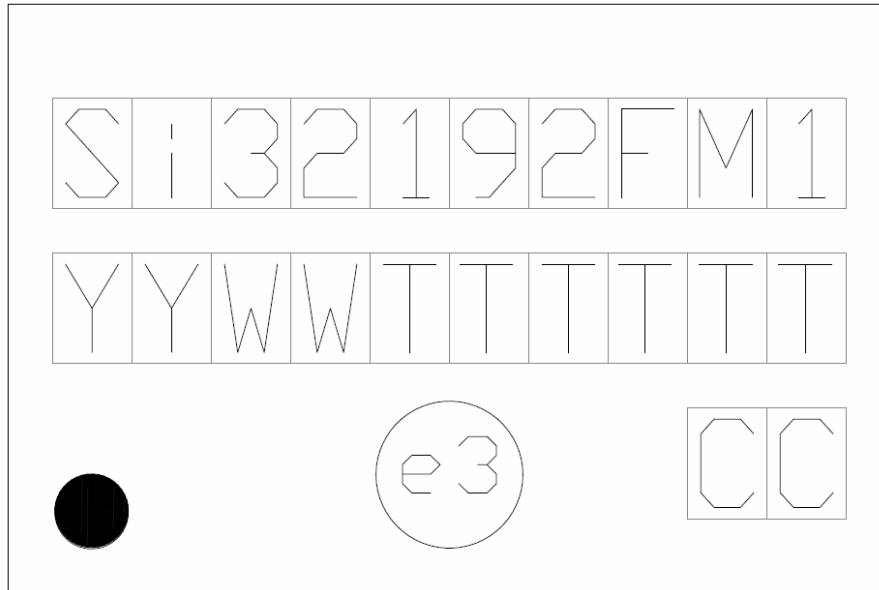

Figure 9.1. 38-Pin QFN Top Marking

Table 9.1. Top Marking Explanation

Mark Method:	Laser	
Pin 1 Mark:	Circle = 0.50 mm Diameter (Bottom-Left-Justified)	
Font Size	0.60 mm Right-Justified	
Line 1 Mark Format:	Device Part Number	Si32192FM1
Line 2 Mark Format:	YY = Year WW = Work Week TTTTTT = Mfg Code	Manufacturing Code from the Assembly Purchase Order form. Assigned by the Assembly House. Corresponds to the year and work week of the assembly release.
Line 3 Mark Format:	Circle = 1.0 mm Diameter Center-Justified CC = Country of Origin ISO Code Abbreviation	"e3" Pb-Free Symbol TH, TW, or CN

10. Revision History

Revision 1.0

June, 2018

- Updated [Table 3.2 Power Supply Characteristics on page 7](#).
- Updated [Table 3.3 AC Characteristics on page 8](#).
 - Updated Idle Channel Noise specification.
- Numerous clarifications throughout.

Revision 0.9

April, 2017

- Initial revision.



SKYWORKS®

**Connecting Everyone
and Everything,
All the Time**



Portfolio

www.skyworksinc.com

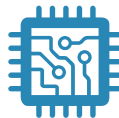

Quality

www.skyworksinc.com/quality



Support & Resources

www.skyworksinc.com/support

Copyright © 2021 Skyworks Solutions, Inc. All Rights Reserved.

Information in this document is provided in connection with Skyworks Solutions, Inc. ("Skyworks") products or services. These materials, including the information contained herein, are provided by Skyworks as a service to its customers and may be used for informational purposes only by the customer. Skyworks assumes no responsibility for errors or omissions in these materials or the information contained herein. Skyworks may change its documentation, products, services, specifications or product descriptions at any time, without notice. Skyworks makes no commitment to update the materials or information and shall have no responsibility whatsoever for conflicts, incompatibilities, or other difficulties arising from any future changes.

No license, whether express, implied, by estoppel or otherwise, is granted to any intellectual property rights by this document. Skyworks assumes no liability for any materials, products or information provided hereunder, including the sale, distribution, reproduction or use of Skyworks products, information or materials, except as may be provided in Skyworks' Terms and Conditions of Sale.

THE MATERIALS, PRODUCTS AND INFORMATION ARE PROVIDED "AS IS" WITHOUT WARRANTY OF ANY KIND, WHETHER EXPRESS, IMPLIED, STATUTORY, OR OTHERWISE, INCLUDING FITNESS FOR A PARTICULAR PURPOSE OR USE, MERCHANTABILITY, PERFORMANCE, QUALITY OR NON-INFRINGEMENT OF ANY INTELLECTUAL PROPERTY RIGHT; ALL SUCH WARRANTIES ARE HEREBY EXPRESSLY DISCLAIMED. SKYWOKS DOES NOT WARRANT THE ACCURACY OR COMPLETENESS OF THE INFORMATION, TEXT, GRAPHICS OR OTHER ITEMS CONTAINED WITHIN THESE MATERIALS. SKYWOKS SHALL NOT BE LIABLE FOR ANY DAMAGES, INCLUDING BUT NOT LIMITED TO ANY SPECIAL, INDIRECT, INCIDENTAL, STATUTORY, OR CONSEQUENTIAL DAMAGES, INCLUDING WITHOUT LIMITATION, LOST REVENUES OR LOST PROFITS THAT MAY RESULT FROM THE USE OF THE MATERIALS OR INFORMATION, WHETHER OR NOT THE RECIPIENT OF MATERIALS HAS BEEN ADVISED OF THE POSSIBILITY OF SUCH DAMAGE.

Skyworks products are not intended for use in medical, lifesaving or life-sustaining applications, or other equipment in which the failure of the Skyworks products could lead to personal injury, death, physical or environmental damage. Skyworks customers using or selling Skyworks products for use in such applications do so at their own risk and agree to fully indemnify Skyworks for any damages resulting from such improper use or sale.

Customers are responsible for their products and applications using Skyworks products, which may deviate from published specifications as a result of design defects, errors, or operation of products outside of published parameters or design specifications. Customers should include design and operating safeguards to minimize these and other risks. Skyworks assumes no liability for applications assistance, customer product design, or damage to any equipment resulting from the use of Skyworks products outside of Skyworks' published specifications or parameters.

Skyworks, the Skyworks symbol, Sky5®, SkyOne®, SkyBlue™, Skyworks Green™, Clockbuilder®, DSPLL®, ISOModem®, ProSLIC®, and SiPHY® are trademarks or registered trademarks of Skyworks Solutions, Inc. or its subsidiaries in the United States and other countries. Third-party brands and names are for identification purposes only and are the property of their respective owners. Additional information, including relevant terms and conditions, posted at www.skyworksinc.com, are incorporated by reference.

Skyworks Solutions, Inc. | Nasdaq: SWKS | sales@skyworksinc.com | www.skyworksinc.com

USA: 781-376-3000 | Asia: 886-2-2735 0399 | Europe: 33 (0)1 43548540 |