

SIEMENS

ICs for Communications

Enhanced Serial Communication Controller
ESCC2

SAB 82532

SAF 82532

Version 3.2

User's Manual 07.96

SAB 82532		
SAF 82532		
Revision History:		Current Version: 07.96
Previous Version: User's Manual 07.93		
Page (in previous Version)	Page (in new Version)	Subjects (major changes since last revision)
-	10	new package provided: P-MQFP-80
-	72	Selectable out-of-band flow control in ASYNC mode: description added
-	75	In-band flow control transparency: description added
-	87	Selectable enhanced resolution BRG: description added
110, 141, 167	124, 170, 208	Timer register (TIMR): description extended for V3.x
107, 127	120, 149	RSTA register, ISR0 register (RME interrupt): description extended
115, 146, 172	133, 179, 217	XBCH, bit XC: description extended
124, 152, 179	144, 187, 227	Baud rate generator register (BGR): description extended
133	157	Channel configuration register 4 (CCR4) in HDLC mode: description extended
138	164	STAR, bit XFW: description extended
140	168	Mode register (MODE) in ASYNC mode: new bits (FRTS, FRCS)
144	175	RFIFO Control Register (RFC) in ASYNC mode: new bit (DXS)
-	198, 237	Channel Configuration Register 4 (CCR4) in ASYNC and BISYNC mode: new register
204	256	XTAL1 clock period, high time and low time: min. values for N-10 version corrected

Edition 07.96

This edition was realized using the software system FrameMaker®.

**Published by Siemens AG,
Bereich Halbleiter, Marketing-
Kommunikation, Balanstraße 73,
81541 München**

© Siemens AG 1996.
All Rights Reserved.

Attention please!

As far as patents or other rights of third parties are concerned, liability is only assumed for components, not for applications, processes and circuits implemented within components or assemblies.

The information describes the type of component and shall not be considered as assured characteristics.

Terms of delivery and rights to change design reserved.

For questions on technology, delivery and prices please contact the Semiconductor Group Offices in Germany or the Siemens Companies and Representatives worldwide (see address list).

Due to technical requirements components may contain dangerous substances. For information on the types in question please contact your nearest Siemens Office, Semiconductor Group.

Siemens AG is an approved CECC manufacturer.

Packing

Please use the recycling operators known to you. We can also help you – get in touch with your nearest sales office. By agreement we will take packing material back, if it is sorted. You must bear the costs of transport.

For packing material that is returned to us unsorted or which we are not obliged to accept, we shall have to invoice you for any costs incurred.

Components used in life-support devices or systems must be expressly authorized for such purpose!

Critical components¹ of the Semiconductor Group of Siemens AG, may only be used in life-support devices or systems² with the express written approval of the Semiconductor Group of Siemens AG.

- 1 A critical component is a component used in a life-support device or system whose failure can reasonably be expected to cause the failure of that life-support device or system, or to affect its safety or effectiveness of that device or system.
- 2 Life support devices or systems are intended (a) to be implanted in the human body, or (b) to support and/or maintain and sustain human life. If they fail, it is reasonable to assume that the health of the user may be endangered.

Table of Contents		Page
1	Introduction	6
1.1	Features	7
1.2	Pin Configuration	9
1.3	Pin Definitions and Functions	11
1.4	Logic Symbol	23
1.5	Functional Block Diagram	24
1.6	System Integration	25
1.6.1	General Aspects	25
1.6.2	Environment	26
1.6.2.1	ESCC2 with SAB 8051 Microcontroller	26
1.6.2.2	ESCC2 with SAB 80188 Microprocessor	27
1.6.2.3	ESCC2 with SAB 80286 Microprocessor and SAB 82258 Advanced DMA Controller (ADMA)	28
1.6.2.4	ESCC2 with 80386 or SAB-R3000 (MIPS)	29
1.6.2.5	ESCC2 with MC 68008	30
1.6.2.6	ESCC2 with MC 68000, 68010, 68012	31
1.6.2.7	ESCC2 with MC 68020, 68030	32
1.6.2.8	Interrupt Cascading	33
2	Basic Functional Principles	37
2.1	General	37
2.2	FIFO Structure	40
3	Microprocessor Interface	42
3.1	Register Set	42
3.2	Data Transfer Modes	44
3.3	Interrupt Interface	44
4	DMA Interface	48
5	HDLC/SDLC Serial Mode	49
5.1	Operating Modes	49
5.2	Procedural Support (layer-2 functions)	53
5.2.1	Full-Duplex LAPB/LAPD Operation	53
5.2.2	Half-Duplex SDLC-NRM Operation	58
5.2.3	Error Handling	61
5.3	SDLC Loop	61
5.4	Special Functions	64
5.4.1	Shared Flags	64
5.4.2	Preamble Transmission	64
5.4.3	CRC-32	64
5.4.4	Extended Transparent Transmission and Reception	64
5.4.5	Cyclic Transmission (fully transparent)	65
5.4.6	Continuous Transmission (DMA mode only)	65
5.4.7	Receive Length Check Feature	66

Table of Contents		Page
5.4.8	One Bit Insertion	66
5.4.9	CRC ON/OFF Feature (version 2 upward)	67
5.4.10	Receive Address Handling (version 2 upward)	67
6	Asynchronous Serial Mode	68
6.1	Character Frame	68
6.2	Data Reception	69
6.2.1	Operating Modes	69
6.2.2	Storage of Data	70
6.3	Data Transmission	70
6.4	Special Features	70
6.4.1	Break Detection/Generation	70
6.4.2	Flow Control by XON/XOFF (version 2 upward)	71
6.4.3	Selectable Out-of-band Flow Control for Transmitter and Receiver (V3.x) .	72
6.4.4	In-band Flow Control Transparency	75
6.4.5	Continuous Transmission (DMA mode only)	75
7	Character Oriented Serial Mode (MONOSYNC/BISYNC)	76
7.1	Data Frame	76
7.2	Data Reception	77
7.3	Data Transmission	78
7.4	Special Functions	79
7.4.1	Preamble Transmission	79
7.4.2	Continuous Transmission (DMA mode only)	79
7.4.3	CRC Parity Inhibit	79
8	Serial Interface (layer-1 functions)	80
8.1	Clock Modes	80
8.2	Clock Recovery (DPLL)	88
8.3	Bus Configuration	91
8.3.1	Bus Access Procedure	91
8.3.2	Collisions	92
8.3.3	Priority (HDLC/SDLC mode only)	92
8.3.4	Timing Modes	93
8.3.5	Functions of RTS Output	93
8.4	Data Encoding	94
8.5	Modem Control Functions (RTS/CTS, CD)	97
8.5.1	RTS/CTS Handshaking	97
8.5.2	Carrier Detect (CD) Receiver Control	98
8.6	Test Mode	99
8.7	Universal Port	99
9	Operational Description	100
9.1	Reset	100
9.2	Initialization	102

Table of Contents		Page
9.3	Operational Phase	105
9.3.1	Data Transmission	105
9.3.1.1	Interrupt Mode	105
9.3.1.2	DMA Mode	108
9.3.2	Data Reception	109
9.3.2.1	Interrupt Mode	109
9.3.2.2	DMA Mode	111
10	Detailed Register Description	112
10.1	Status/Control Registers in HDLC Mode	112
10.1.1	Register Addresses	112
10.1.2	Register Definitions	114
10.2	Status/Control Registers in ASYNC Mode	159
10.2.1	Register Addresses	159
10.2.2	Register Definitions	161
10.3	Status/Control Registers in BISYNC Mode	199
10.3.1	Register Addresses	199
10.3.2	Register Definitions	201
11	Electrical Characteristics	238
11.1	Absolute Maximum Ratings	238
11.2	DC Characteristics	238
11.3	Capacitances	240
11.4	AC Characteristics	241
11.4.1	Microprocessor Interface	242
11.4.1.1	Siemens/Intel Bus Interface Mode	242
11.4.1.2	Motorola Bus Interface Mode	250
11.4.2	Parallel Port Timing	255
11.4.3	Serial Interface	256
11.4.3.1	Clock Input Timing	256
11.4.3.2	Receive Cycle Timing	257
11.4.3.3	Transmit Cycle Timing	259
11.4.3.4	Strobe Timing (clock mode 1)	261
11.4.3.5	Synchronization Timing (clock mode 5)	263
11.4.3.6	Reset Timing	264
12	Package Outlines	265
13	Appendix	267
13.1	Baud Rate Generator Tables	267
13.2	Development Board EASY532	270

1 Introduction

The Enhanced Serial Communication Controller ESCC2 (SAB 82532/SAF 82532) is a multiprotocol data communication controller with two symmetrical serial channels. It has been designed to implement high-speed communication links and to reduce hardware and software overhead needed for serial synchronous/asynchronous communications.

Each channel contains an independent clock generator, DPLL, encoder/decoder and programmable protocol hardware. Data communication with asynchronous, synchronous character oriented, and HDLC based protocols with extended support of X.25 LAPB, the ISDN LAPD, and SDLC protocols is implemented. Like the SAB 82525 (HSCX) which is a functional subset of the ESCC2, the ESCC2 is capable of handling a large set of layer-2 protocol functions independently of the host processor.

The version 82532N-10 of the Enhanced Serial Communication Controller (ESCC2) opens a wide area for applications which use time division multiplex methods (e.g. time-slot oriented PCM systems, systems designed for packet switching, ISDN applications) by its programmable telecom-specific features. In this special operating mode (clock mode 5), which is applicable to all serial modes (HDLC/SDLC, ASYNC, BISYNC), the ESCC2 can transmit or receive data packets in one of up to 64 time-slots of programmable width.

The device is controlled via a parallel 16-bit wide interface which is directly compatible with the most popular 8/16 bit microprocessors (Siemens/Intel or Motorola type). The internal FIFOs (64 bytes per direction and channel) with additional DMA capability provide a powerful interface to the higher layers implemented in a microcontroller. For interrupt controlled systems, the ESCC2 supports daisy chaining and interrupt vector generation.

The ESCC2 is fabricated using SIEMENS advanced CMOS technology and is available in a P-LCC-68 and a P-MQFP-80 package.

Applications

- Universal, multiprotocol communication board for Workstation- and PC-boards
- Terminal controllers
- Computer peripherals
- Time slotted packet networks
- Multimaster communication networks
- LANs

CMOS IC

1.1 Features

Serial Interface

- Two independent full duplex serial channels
 - On chip clock generation or external clock source
 - On chip DPLL for clock recovery of each channel
 - Two independent baud rate generators
 - Independent time-slot assignment for each channel with programmable time-slot length (1 ... 256 bits)
- Async, sync character oriented (MONOSYNC/BISYNC) or HDLC/SDLC modes (including SDLC LOOP)
- Transparent receive/transmit of data bytes without framing
- NRZ, NRZI, FM and Manchester encoding
- Modem control lines (RTS, CTS, CD)
- CRC support:
 - HDLC/SDLC: CRC-CCITT or CRC-32 (automatic handling for transmit/receive direction)
 - BISYNC: CRC-16 or CRC-CCITT (support for transmit direction)

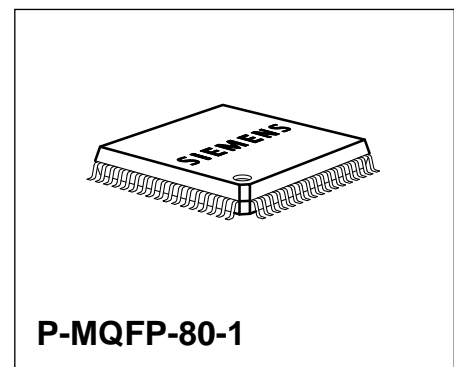
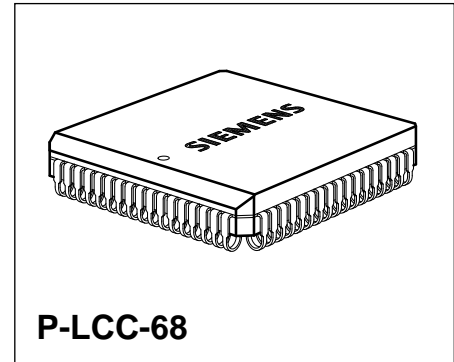

Type	Ordering Code	Package	Max. Data Rate		Time Slot Mode
			ext.	int. (DPLL) clocked	
SAB 82532 N	Q67101-H6790	P-LCC-68	2.048 Mbit/s	2 Mbit/s	no
SAB 82532 N-10	Q67101-H6791	P-LCC-68	10 Mbit/s	2 Mbit/s	yes
SAB 82532 H	Q67101-H6788	P-MQFP-80	2.048 Mbit/s	2 Mbit/s	no
SAB 82532 H-10	Q67101-H6789	P-MQFP-80	10 Mbit/s	2 Mbit/s	yes
SAF 82532 N-10	on request	P-LCC-68	10 Mbit/s	2 Mbit/s	yes
SAF 82532 H-10	on request	P-MQFP-80	10 Mbit/s	2 Mbit/s	yes

- Support of bus configuration by collision detection and resolution
- Statistical multiplexing
- Continuous transmission of 1 to 32 bytes possible
- Programmable preamble (8 bit) with selectable repetition rate (HDLC/SDLC and BISYNC)
- Data rate up to 10 Mbit/s
- Master clock mode with data rate up to 4 Mbit/s

Protocol Support (HDLC/SDLC)

- Various types of protocol support depending on operating mode
 - Auto mode (automatic handling of S- and I-frames)
 - Non-auto mode
 - Transparent mode
- Handling of bit oriented functions
- Support of LAPB/LAPD/SDLC/HDLC protocol in auto mode (I- and S-frame handling)
- Modulo-8 or modulo-128 operation
- Programmable time-out and retry conditions
- Programmable maximum packet size checking

MP Interface and Ports

- 64 byte FIFOs per channel and direction (byte or word access)
- 8/16 bit microprocessor bus interface (Intel or Motorola type)
- All registers directly accessible (byte and word access)
- Efficient transfer of data blocks from/to system memory via DMA or interrupt request
- Support of Daisy Chaining and Slave Operation with Interrupt Vector generation
- 8-bit programmable bi-directional universal port

General

- Advanced CMOS technology
- Low power consumption: active 40 mW at 2 MHz/standby 5 mW (typical values)
- P-LCC-68 Package
- P-MQFP-80 Package

1.2 Pin Configuration
(top view)

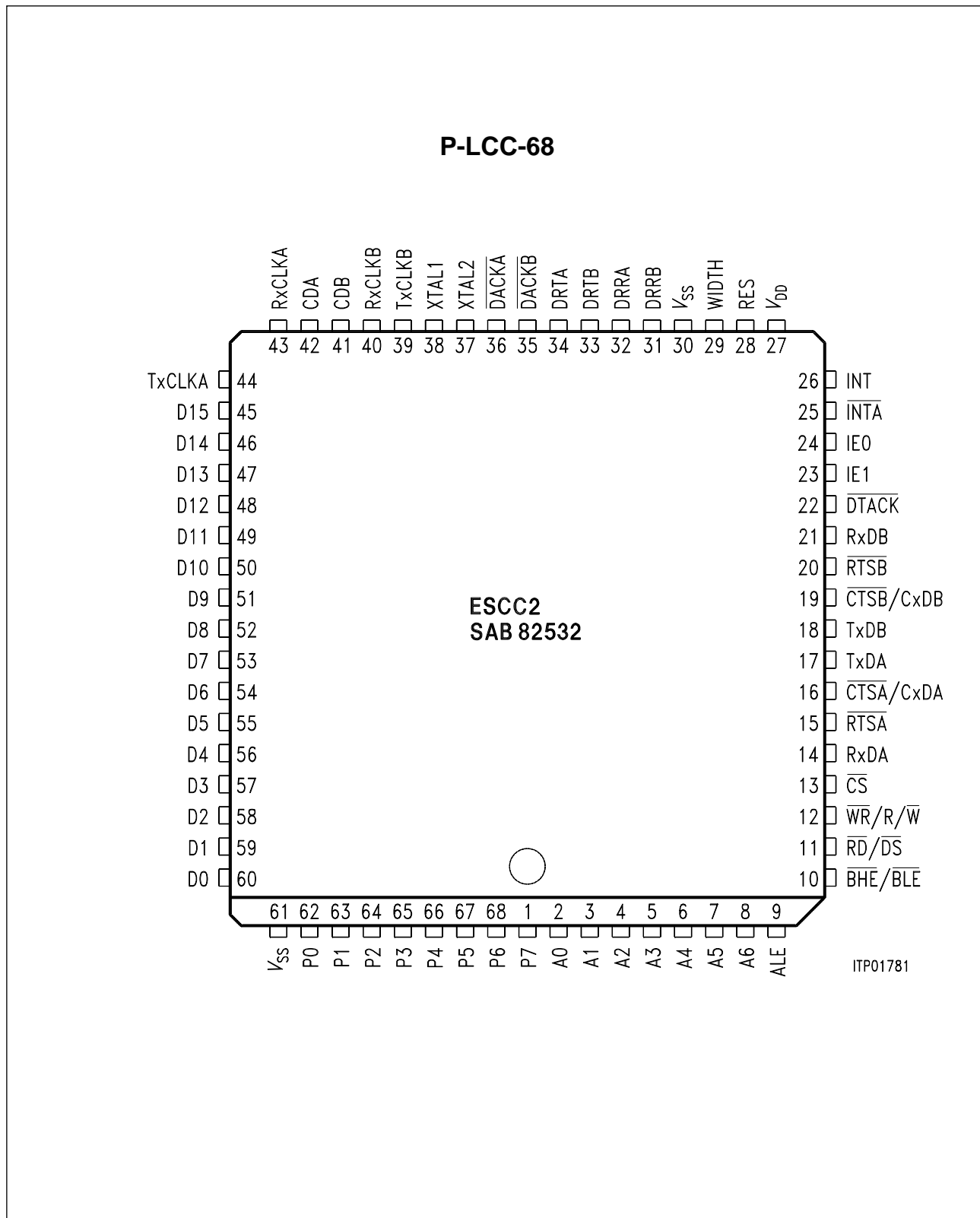

Figure 1

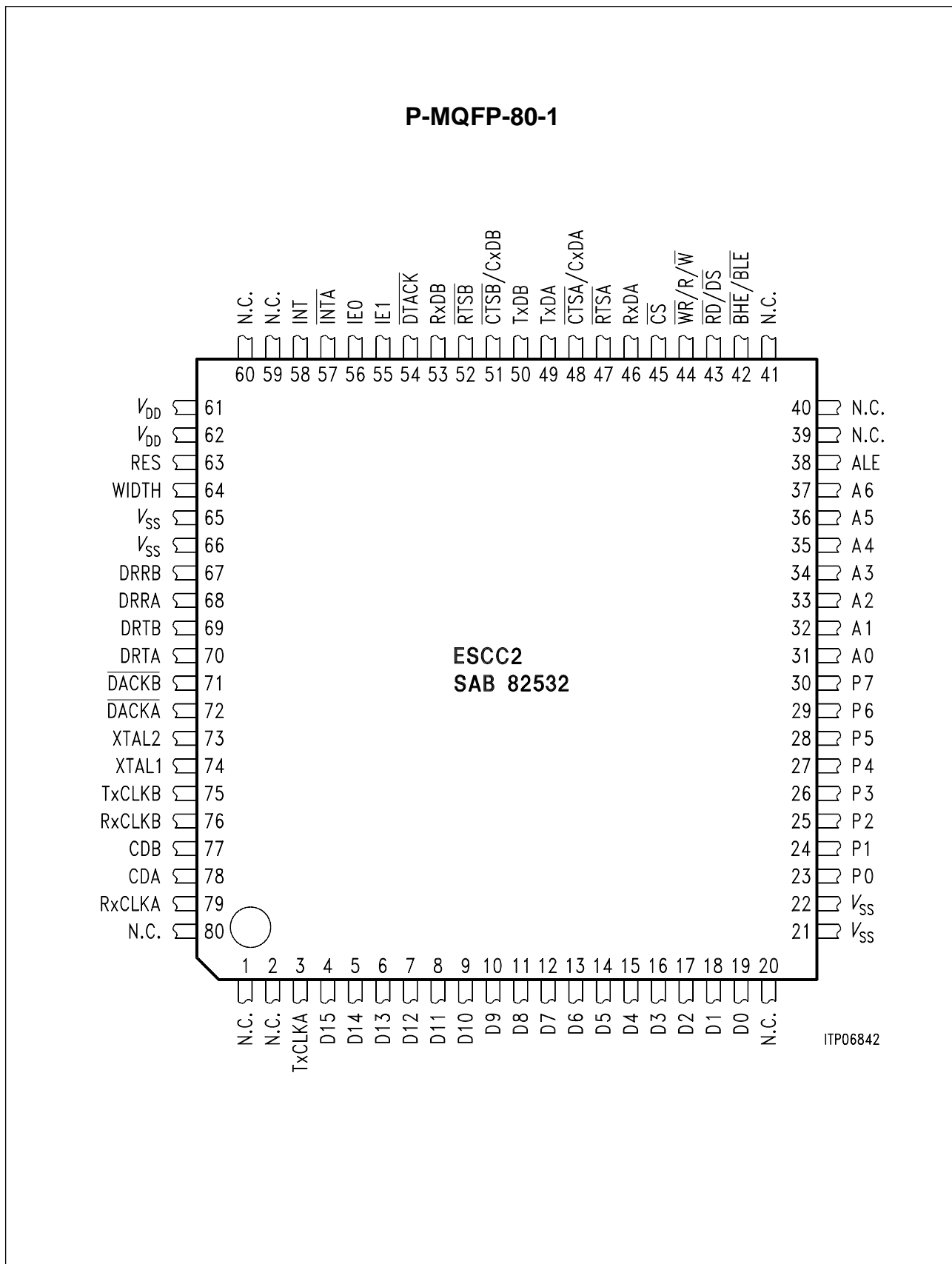

Figure 2

1.3 Pin Definitions and Functions

Pin No.		Symbol	Input (I) Output (O)	Function
P-LCC-68	P-MQFP-80			
2 ... 8	31 ... 37	A0 ... A6	I	Address Bus These inputs interface with seven bits of the system's address bus to select one of the internal registers for read or write.
60 ... 45	19 ... 4	D0 ... D15	I/O	Data Bus Bi-directional three-state data lines which interface with the system's data bus. Their configuration is controlled by the level of pin WIDTH: <ul style="list-style-type: none"> – 8-bit mode (WIDTH = 0): D0 ... D7 are active. D8 ... D15 are in high impedance and have to be connected to V_{DD} or V_{SS}. – 16-bit mode (WIDTH = 1): D0 ... D15 are active. In case of byte transfers, the active half of the bus is determined by A0 and $\overline{BHE}/\overline{BLE}$ and the selected bus interface mode (via ALE). The unused half is in high impedance. For detailed information, refer to chapter 3.1.
9	38	ALE	I	Address Latch Enable The level at this pin defines the bus interface mode: <ul style="list-style-type: none"> Fixed to \overline{V}_{SS}: Demultiplexed Siemens/Intel bus interface Fixed to '1': Demultiplexed Motorola bus interface Switching: Multiplexed Siemens/Intel bus interface The address information provided on lines A0 ... A6 is internally latched with the falling edge of ALE. This function allows the ESCC2 to be directly connected to a multiplexed address/data bus. In this case, pins A0 ... A6 must be externally connected to the Data Bus pins (e.g. D0 ... D6 for 8-bit CPUs).

Note: All unused input pins have to be connected to a defined level.

1.3 Pin Definitions and Functions (cont'd)

Pin No.		Symbol	Input (I) Output (O)	Function
P-LCC-68	P-MQFP-80			
11	43	$\overline{\text{RD/DS}}$	I	<p>Read Enable (Siemens/Intel bus mode) This signal indicates a read operation. When the $\overline{\text{ESCC2}}$ is selected via $\overline{\text{CS}}$ the $\overline{\text{RD}}$ signal enables the bus drivers to output data from an internal register addressed via A0 ... A6 on to Data Bus. For more information about control/status register and FIFO access in the different bus interface modes refer to chapter 2. If DMA transfer is selected via $\overline{\text{DACKA}}$ or $\overline{\text{DACKB}}$, the $\overline{\text{RD}}$ signal enables the bus drivers to put data from the corresponding Receive FIFO on the Data Bus. Inputs A1 ... A6 are ignored. A0 and $\overline{\text{BHE/BLE}}$ are used to select byte or word access.</p> <p>Data Strobe (Motorola bus mode) This pin serves as input to control read/write operations.</p>
12	44	$\overline{\text{WR/R/W}}$	I	<p>Write Enable (Siemens/Intel bus mode) This signal indicates a write operation. When $\overline{\text{CS}}$ is active the $\overline{\text{ESCC2}}$ loads an internal register with data provided via the Data Bus. For more information about control/status register and FIFO access in the different bus interface modes refer to chapter 2. If DMA transfer is selected via $\overline{\text{DACKA}}$ or $\overline{\text{DACKB}}$, the $\overline{\text{WR}}$ signal enables latching data from the Data Bus on the top of the corresponding Transmit FIFO. Inputs A0 ... A6 are ignored.</p> <p>Read/Write Enable (Motorola bus mode) This signal distinguishes between read and write operation.</p>
13	45	$\overline{\text{CS}}$	I	<p>Chip Select A low signal selects the $\overline{\text{ESCC2}}$ for read/write operations. $\overline{\text{CS}}$ has no function in interrupt acknowledge or DMA cycles.</p>

1.3 Pin Definitions and Functions (cont'd)

Pin No.		Symbol	Input (I) Output (O)	Function
P-LCC-68	P-MQFP-80			
28	63	RES	I	<p>Reset A high signal on this pin forces the ESCC2 into reset state. During Reset the ESCC2 is in power up mode, after Reset in power-down mode. Re-activation of each channel is done via bit CCR0:PU (refer to chapter 9.2).</p> <p>During Reset</p> <ul style="list-style-type: none"> – all uni-directional output stages are in high-impedance state, – all bi-directional output stages (data bus) are in high-impedance state, – output XTAL2 is in high-impedance if input XTAL1 is 'high' (the internal oscillator is disabled during reset), – signals \overline{RD} and \overline{INTA} have to be 'high'
10	42	$\overline{BHE}/$ \overline{BLE}	I	<p>Bus High Enable (Siemens/Intel bus mode) If 16-bit bus interface mode is enabled, this signal indicates a data transfer on the upper byte of the data bus (D8...D15). In 8-bit bus interface mode this signal has no function and should be tied to V_{DD}. Refer to chapter 3.1 for detailed information.</p> <p>Bus Low Enable (Motorola bus mode) If 16-bit bus interface mode is enabled, this signal indicates a data transfer on the lower byte of the data bus (D0 ... D7). In 8-bit bus interface mode this signal has no function and should be tied to V_{DD}. Refer to chapter 3.1 for detailed information.</p>
29	64	WIDTH	I	<p>Width Of Bus Interface (Bus Interface Mode) A low signal on this input selects the 8-bit bus interface mode. A high signal on this input selects the 16-bit bus interface mode. In this case word transfer to/from the internal registers is enabled. Moreover, <u>byte transfers</u> (in conjunction with A0 and BHE/BLE) are allowed, too.</p>

1.3 Pin Definitions and Functions (cont'd)

Pin No.		Symbol	Input (I) Output (O)	Function
P-LCC-68	P-MQFP-80			
22	54	$\overline{\text{DTACK}}$	O (oD)	<p>Data Transfer Acknowledge</p> <p>During a bus cycle (read/write, asynchronous bus), this signal indicates that ESCC2 is ready for data transfer. The signal remains active until the data strobe ($\overline{\text{DS}}$, $\overline{\text{RD}}$ or $\overline{\text{WR}}$) and/or the Chip Select signal ($\overline{\text{CS}}$) or the Interrupt Acknowledge ($\overline{\text{INTA}}$) go inactive. An external resistor has to be tied to V_{DD} if this function is used.</p>
26	58	INT	O (oD)	<p>Interrupt Request</p> <p>INT serves as general interrupt request which may include all serial mode specific interrupt sources and the requests of the 8-bit universal port if programmed. These interrupt sources can be masked via registers IMR0, IMR1 (channel) and PIM (universal port). Interrupt status is reported via registers GIS (Global Interrupt Status), ISR0, ISR1 (channel) and PIS (universal port).</p> <p>Output characteristics (push-pull active low/high, open drain) are determined by programming the IPC register.</p> <p>In Daisy Chain cascading mode INT signal generation is only enabled if the Interrupt Enable input IE1 is active (logical '1').</p> <p>INT is reset if</p> <ul style="list-style-type: none"> – interrupts are disabled in Daisy Chain cascading mode (pin IE1 = '0'), – no further interrupt is pending, i.e. all interrupt status bits are reset.

1.3 Pin Definitions and Functions (cont'd)

Pin No.		Symbol	Input (I) Output (O)	Function
P-LCC-68	P-MQFP-80			
25	57	$\overline{\text{INTA}}$	I	<p>Interrupt Acknowledge</p> <p>If the interrupt is acknowledged via pin $\overline{\text{INTA}}$, an interrupt vector is output on D0 ... D7. All interrupt sources are organized in 8 groups with fixed priority (refer to chapter 2). The generated interrupt vector refers to the interrupt group with currently highest priority (although more than one interrupt source/group may be active). Reaction on $\overline{\text{INTA}}$ signal depends on the bus interface mode and the cascading mode in conjunction with the Interrupt Enable pins IE0 and IE1 (ref. to IPC register):</p> <p>Motorola bus mode: INT is reset with the rising edge of the following valid $\overline{\text{INTA}}$ cycle if no further interrupt is pending. The interrupt vector is output with signal $\overline{\text{DS}}$.</p> <p>Siemens/Intel bus mode: INT is reset with the rising edge of the second valid $\overline{\text{INTA}}$ cycle (2-cycle '86 mode) if no further interrupt is pending.</p> <p>Slave mode: Interrupt acknowledge is accepted if an interrupt signal has been generated and the slave address provided via IE0, IE1 corresponds to the programmed value (IPC register).</p> <p>Daisy Chaining mode: Interrupt acknowledge is accepted if an interrupt signal has been generated and Interrupt Enable input IE1 is active during the following $\overline{\text{INTA}}$ cycle.</p> <p><i>Note: Pins $\overline{\text{CS}}$, $\overline{\text{DACKA}}$ and $\overline{\text{DACKB}}$ have to be inactive during an $\overline{\text{INTA}}$ cycle. If pin $\overline{\text{INTA}}$ is not used, it has to be tied to V_{DD}.</i></p>

1.3 Pin Definitions and Functions (cont'd)

Pin No.		Symbol	Input (I) Output (O)	Function
P-LCC-68	P-MQFP-80			
24	56	IE0	I/O	<p>Interrupt Enable 0, 1</p> <p>The function depends on the selected cascading mode:</p> <p>Slave mode: IE0 and IE1 are inputs. Interrupt acknowledge is accepted if an interrupt signal has been generated and the slave address provided via IE0, IE1 corresponds to the programmed value (IPC register).</p> <p>If not used, IE0 and IE1 should be tied to GND and the slave address should be set to '0' (e.g. single device application).</p> <p>Daisy Chaining mode: IE0 is output, IE1 is input.</p> <p>Normally, IE1 is connected to the IE0 pin of devices with higher priority. If not used, IE1 has to be fixed to '1'.</p> <p>If IE1 is reset ('0')</p> <ul style="list-style-type: none"> – the IE0 output is reset immediately, – an active INT signal will be prohibited or aborted. <p>As long as \overline{INTA} input is inactive, IE1 = '1' enables INT signal generation. If INT goes active, pin IE0 immediately is set to '0'. Interrupt acknowledge is accepted if the Interrupt Enable input IE1 is active during the following \overline{INTA} cycle. During this cycle, and additionally 'till the end of the second \overline{INTA} cycle in Siemens/Intel bus mode, triggering of INT signal generation is prohibited, i.e. no interrupt will be generated while (another) device is under service. This is valid even for devices with higher priority.</p> <p>Pin IE0 returns to active state (logical '1') when INT is reset and IE1 input is high.</p>
23	55	IE1	I	

1.3 Pin Definitions and Functions (cont'd)

Pin No.		Symbol	Input (I) Output (O)	Function
P-LCC-68	P-MQFP-80			
34 33	70 69	DRTA DRTB	O	<p>DMA Request Transmitter (channel A/channel B) The transmitter of ESCC2 requests a DMA transfer by activating this line. The request remains active as long as the respective Transmit FIFO requires data transfers.</p> <p>The amount of data bytes to be transferred from the system memory to the ESCC2 (= byte count) must be written first to the XBCH, XBCL registers. Always blocks of data ($n \times 32$ bytes + REST, $n = 0, 1, \dots$) are transferred 'till the Byte Count is reached.</p> <p>DRTn is deactivated with the beginning of the last write cycle.</p>
32 31	68 67	DRRA DRRB	O	<p>DMA Request Receiver (channel A/channel B) The receiver of ESCC2 requests a DMA transfer by activating this line. The request remains active as long as the corresponding Receive FIFO requires data transfers, thus always blocks of data are transferred.</p> <p>DRRn is deactivated immediately following the falling edge of the last read cycle.</p>

1.3 Pin Definitions and Functions (cont'd)

Pin No.		Symbol	Input (I) Output (O)	Function
P-LCC-68	P-MQFP-80			
36 35	72 71	$\overline{\text{DACKA}}$ $\overline{\text{DACKB}}$	I	<p>DMA Acknowledge (channel A/channel B) A low signal on these pins informs the ESCC2 that the requested DMA cycle controlled via DRTA/B or DRRA/B is in progress, i.e. the DMA controller has achieved bus mastership from the CPU and will start data transfer cycles (either write or read). In conjunction with a read or write operation these inputs serve as Access Enable (similar to CS) to the respective FIFOs. If $\overline{\text{DACK}}$ is active, the input to pins A1 ... A6 is ignored and the FIFOs are implicitly selected. A0 and BHE/BLE are used to select byte or word access. If not used, these pins must be connected to V_{DD}.</p>
14 21	46 53	RxDA RxDB	I (O/oD)	<p>Receive Data (channel A/channel B) Serial data is received on these pins. May be switched to TxD function via bit CCR2:SOC1.</p>
43 40	79 76	RxCLKA RxCLKB	I	<p>Receive Clock (channel A/channel B) The function of these pins depends on the selected clock mode. In each channel, RxCLKn may supply either</p> <ul style="list-style-type: none"> – the receive clock (clock mode 0), or – the receive and transmit clock (clock mode 1, 5), or – the clock input for the baud rate generator (clock mode 2, 3).

1.3 Pin Definitions and Functions (cont'd)

Pin No.		Symbol	Input (I) Output (O)	Function
P-LCC-68	P-MQFP-80			
15 20	47 52	$\overline{\text{RTSA}}$ $\overline{\text{RTSB}}$	O	<p>Request to Send (channel A/channel B) When the RTS bit in the MODE register is set, the $\overline{\text{RTS}}$ signal goes low. When the RTS bit is reset, the signal goes high if the transmitter has finished and there is no further request for a transmission. In bus configuration, $\overline{\text{RTS}}$ can be programmed via CCR2 to:</p> <ul style="list-style-type: none"> – go low during the actual transmission of a frame shifted by one clock period, excluding collision bits. – go low during reception of a data frame. – stay always high ($\overline{\text{RTS}}$ disabled).
16 19	48 51	$\overline{\text{CTSA}}$ / CxDA $\overline{\text{CTSB}}$ / CxDB	I	<p>Clear to Send (channel A/channel B) A low on the $\overline{\text{CTS}}_n$ input enables the respective transmitter. Additionally, an interrupt may be issued if a state transition occurs at the $\overline{\text{CTS}}_n$ pin (programmable feature). If no 'Clear To Send' function is required, the $\overline{\text{CTS}}_n$ inputs can be directly connected to GND.</p> <p>Collision Data (channel A/channel B) In a bus configuration, the external serial bus must be connected to the corresponding CxDn pin for collision detection.</p>

1.3 Pin Definitions and Functions (cont'd)

Pin No.		Symbol	Input (I) Output (O)	Function
P-LCC-68	P-MQFP-80			
42 41	78 77	CDA CDB	I	<p>Carrier Detect (channel A/channel B) The function of this pin depends on the selected clock mode. It can supply</p> <ul style="list-style-type: none"> – either a modem control or a general purpose input (clock modes 0, 2, 3, 4, 6, 7). If auto-start is programmed, it functions as a receiver enable signal. – or a receive strobe signal (clock mode 1). – or a frame synchronization signal in time-slot oriented operation mode (clock mode 5). <p>Additionally, an interrupt may be issued if a state transition occurs at the CDn pin (programmable feature).</p>
17 18	49 50	TxDA TxDB	O/oD (I)	<p>Transmit Data (channel A/channel B) Transmit data is shifted out via these pins. They can be programmed to be either a push-pull or open drain output to support bus configurations. <i>Note: Pin TxD is 'OR'ed with pin \overline{RTS} if NRZI encoding and IDLE as Interframe</i> <i>Note: Time Fill are selected and bit MODE:RTS is reset. May be switched to RxD function via bit CCR2:SOCl.</i></p>

1.3 Pin Definitions and Functions (cont'd)

Pin No.		Symbol	Input (I) Output (O)	Function
P-LCC-68	P-MQFP-80			
44 39	3 75	TxCLKA TxCLKB	I/O	<p>Transmit Clock (channel A/channel B) The function of this pin depends on the selected clock mode and the value of the SSEL bit (CCR2 register). For detailed information about the clock modes refer to chapter 2.</p> <p>If programmed as an input, this pin supplies either</p> <ul style="list-style-type: none"> – the transmit clock for the channel (clock mode 0, 2, 6; SSEL bit in CCR2 is reset), or – a transmit strobe signal for the channel (clock mode 1). <p>If programmed as an output (bit CCR2:TOE is set), this pin supplies either</p> <ul style="list-style-type: none"> – the transmit clock for the channel which is generated <ul style="list-style-type: none"> • either from the baud rate generator (clock mode 2, 3, 6, 7; SSEL bit in CCR2 is set), • or from the DPLL circuit (clock mode 3, 7; SSEL bit in CCR2 is reset) • or from the crystal oscillator (clock mode 4), • or an active-low tri-state control signal marking the programmed transmit time-slot (clock mode 5) if bit CCR2:TOE is set.
38 37	74 73	XTAL1 XTAL2	I (O)	<p>Crystal Connection If the internal oscillator is used for clock generation the external crystal has to be connected to these pins. Moreover, XTAL1 may be used as common clock input for channel A and channel B provided by an external clock generator. All versions: common use for both channels in clock modes 4, 6, 7. Version 2 upward: additionally used in clock mode 0b and for master clock applications.</p>

1.3 Pin Definitions and Functions (cont'd)

Pin No.		Symbol	Input (I) Output (O)	Function
P-LCC-68	P-MQFP-80			
62 ... 68,1	23 ... 30	P0 ... P7	I/O	<p>Parallel Port</p> <p>A general purpose 8-bit bi-directional parallel port is provided on pins P0 ... P7. Every pin is individually programmable to operate as an output or an input (Port Configuration Register PCR).</p> <ul style="list-style-type: none"> – If defined as output, the state of the pin is directly controlled via the microprocessor interface (Port Value Register PVR). – If defined as input, its state can be read via PVR. All changes may be indicated via an interrupt status (Port Interrupt Mask register PIM, Port Interrupt Status register PIS, interrupt is output on pin INT).
30 61	21, 22, 65, 66	V_{SS}	I	<p>Ground (0 V)</p> <p>For correct operation, all pins have to be connected to ground.</p>
27	61, 62	V_{DD}	I	Positive power supply

Note: All unused input pins have to be connected to a defined level.

1.4 Logic Symbol

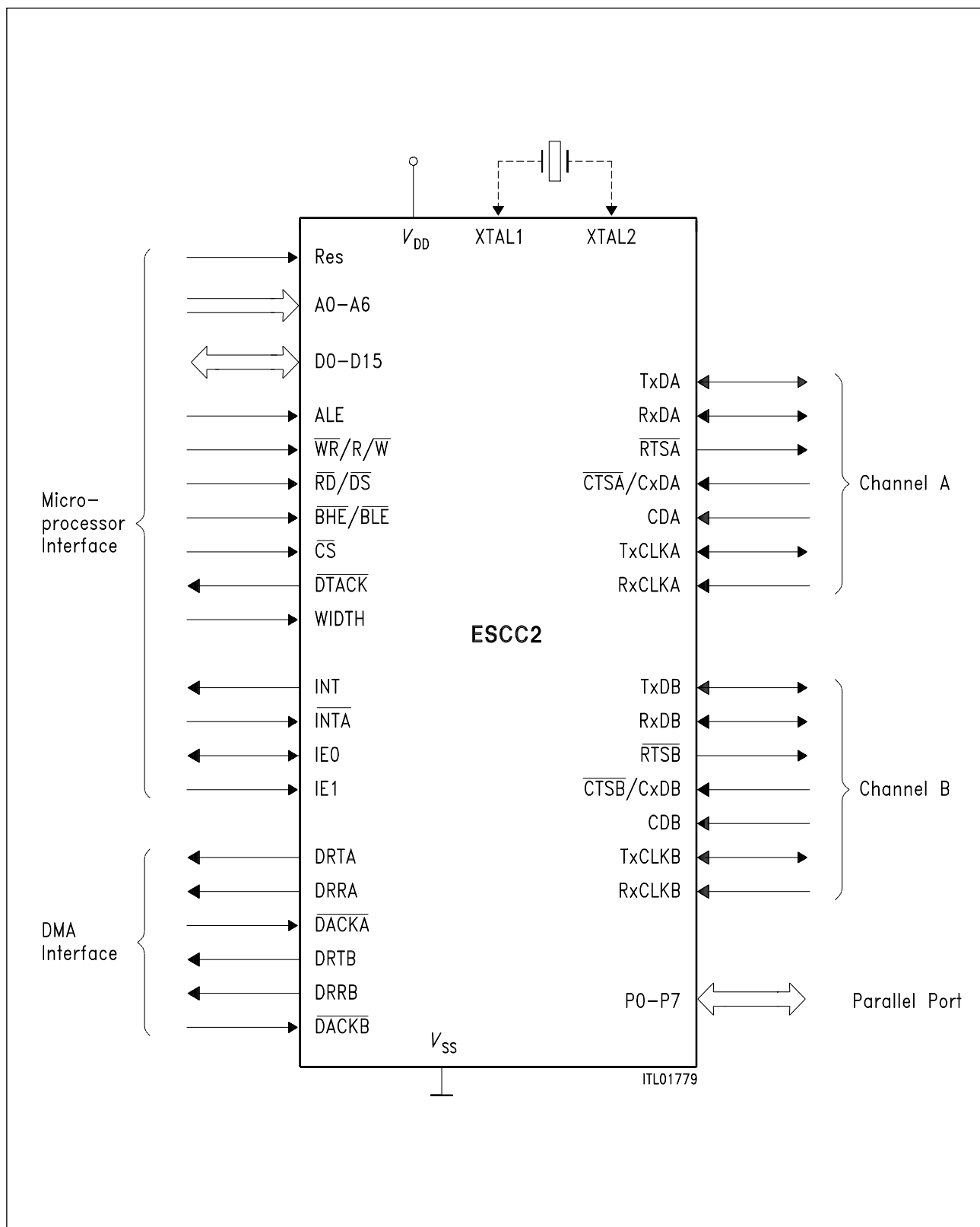

Figure 3
ESCC2 Logic Symbol

1.5 Functional Block Diagram

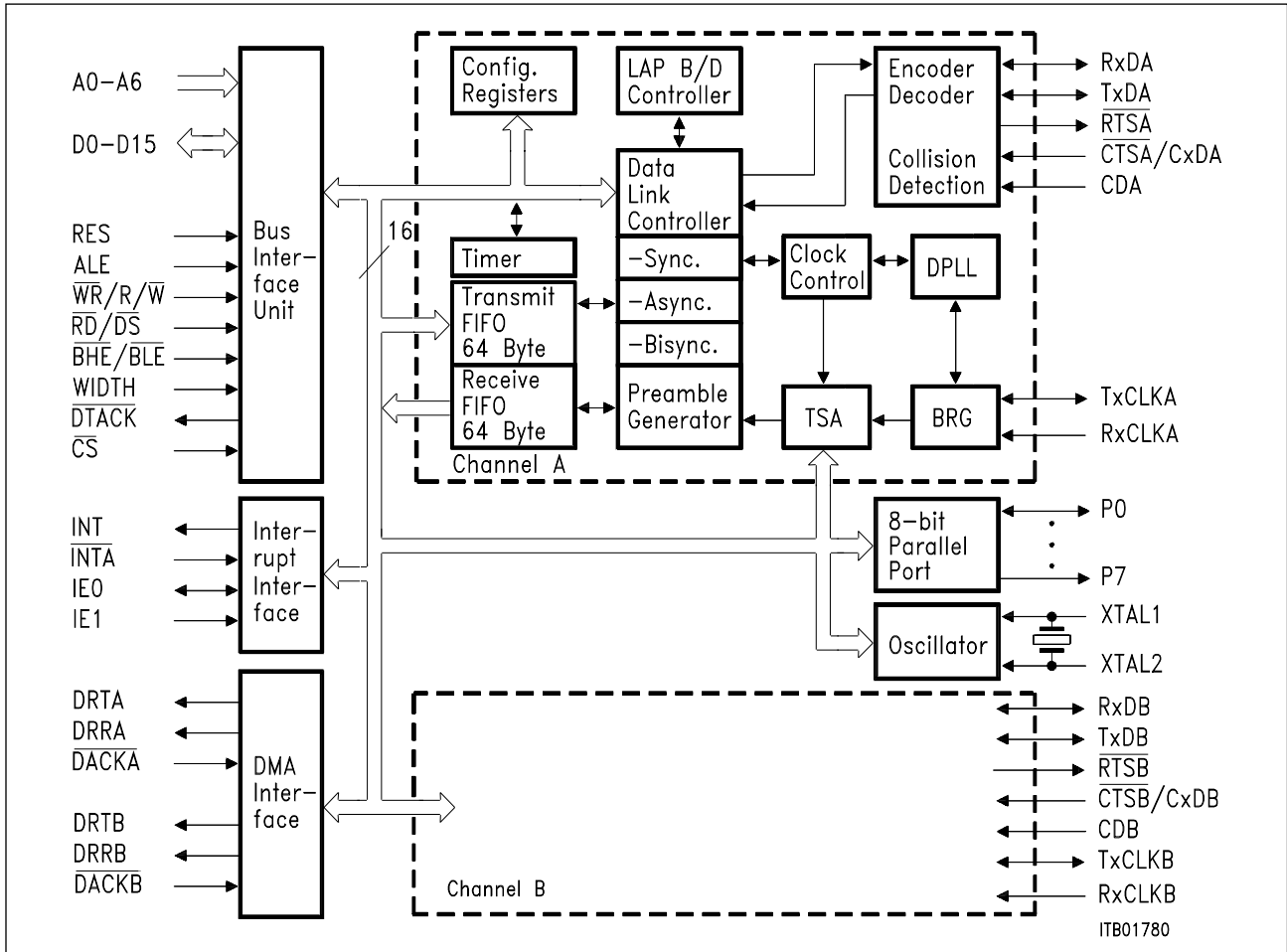

Figure 4
Functional Block Diagram SAB 82532/SAF 82532

The ESCC2 (SAB 82532/SAF 82532) comprises two completely independent full-duplex serial interfaces (channel A and channel B) which support HDLC/SDLC, BISYNC and ASYNC protocols. Layer-1 functions are performed by means of internal oscillator, Baud Rate Generator (BRG), Digital Phase Locked Loop (DPLL), and Time-Slot Assignment circuits (TSA, only available for versions SAB/SAF 82532 N-10 and SAB/SAF 82532 H-10). Encoding/decoding of serial data can be done by using NRZ, NRZI, FM0, FM1 and Manchester encoding schemes. An 8-bit universal bi-directional port is provided which can be used for additional modem control lines or for general I/O purposes.

Associated with each serial channel is a set of independent command and status registers and 64-byte deep FIFOs for transmit and receive direction. Access is done via the flexible 8/16-bit microprocessor interface. DMA capability has been added to the ESCC2 by means of a 4-channel DMA interface with one DMA request line for each transmitter and receiver of both channels. The interrupt structure of ESCC2 supports interrupt driven systems using interrupt polling, daisy chaining or interrupt vector control.

1.6 System Integration

1.6.1 General Aspects

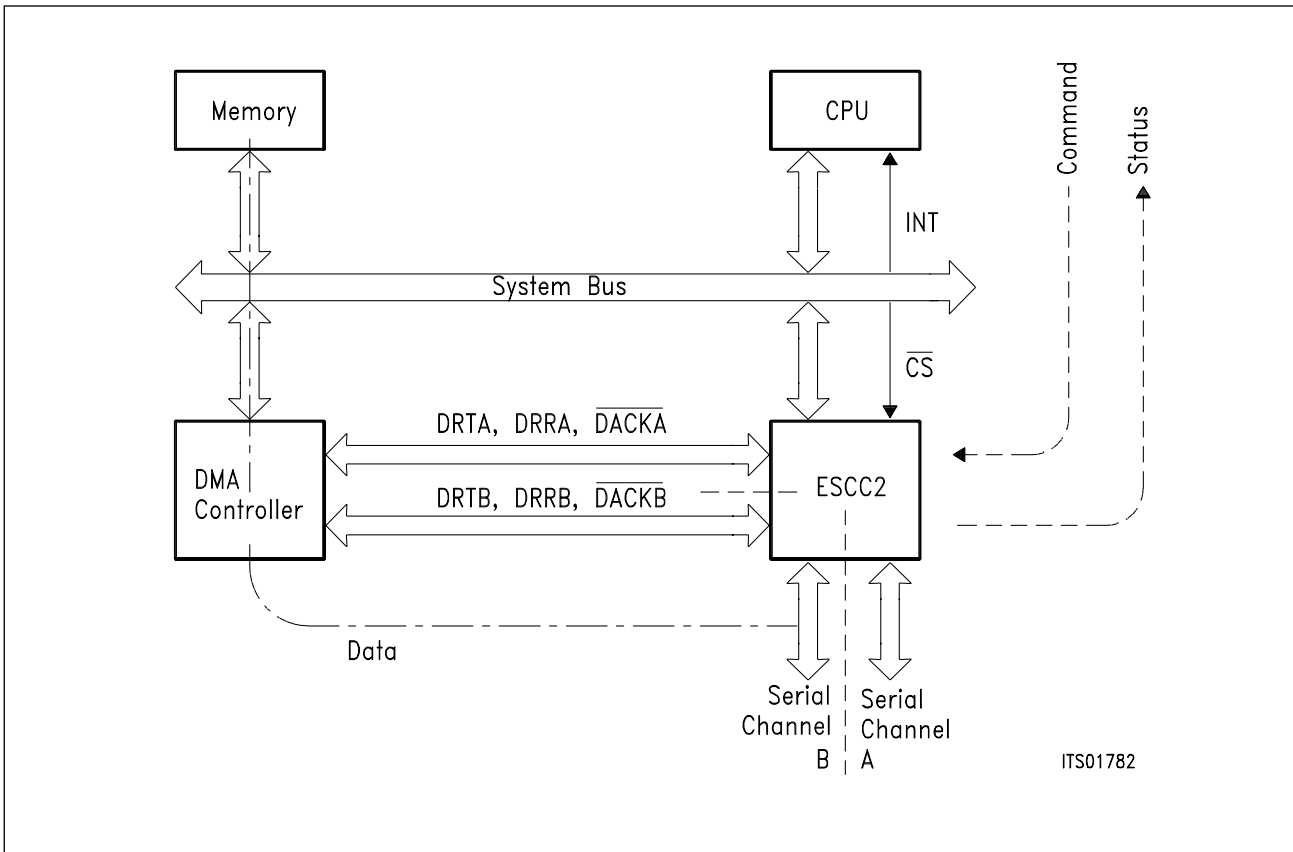

Figure 5
General System Integration of ESCC2

Figure 5 gives a general overview of system integration of ESCC2.

The ESCC2's bus interface consists of an 8/16-bit bidirectional data bus (D0 ... D15), seven Address Line inputs (A0 ... A6), three control inputs ($\overline{RD/DS}$, $\overline{WR/R/W}$, \overline{CS}), four signals for interrupt support (INT, \overline{INTA} , IE0, IE1) and a 4-channel DMA interface (DRTA, DRRA, \overline{DACKA} , DRTB, DRRB, \overline{DACKB}). Mode input pins (strapping options) allow the bus interface to be configured for 8/16-bit bus width and for either Siemens/Intel or Motorola environment.

Generally, there are two types of transfers occurring via the system bus:

- Command/Status transfers, which are always controlled by the CPU. The CPU sets the operation mode (initialization), controls function sequences and gets status information by writing or reading the ESCC2's registers (via \overline{CS} , \overline{WR} or \overline{RD} , and register address via A0 ... A6).
- Data Transfers, which are effectively performed by DMA without CPU interaction using the ESCC2's DMA interface (DMA mode). Optionally, interrupt controlled data transfer can be done by the CPU (interrupt mode).

1.6.2 Environment

1.6.2.1 ESCC2 with SAB 8051 Microcontroller

For cost-sensitive applications, the ESCC2 can be interfaced with a small 8051 microcontroller system (without DMA support) very easily as shown in **figure 6**.

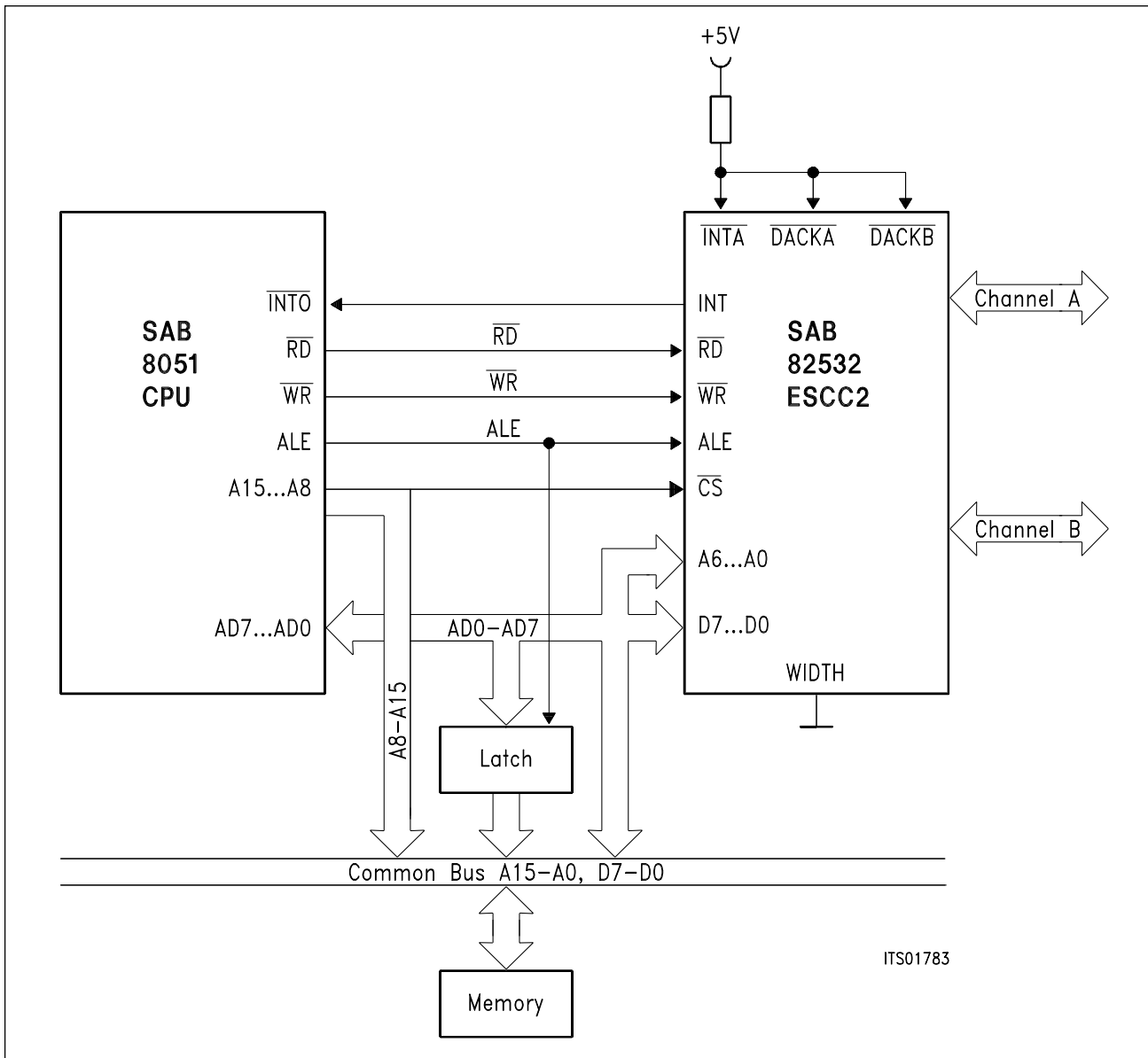

Figure 6
ESCC2 with SAB 8051 CPU

Although the ESCC2 provides a demultiplexed bus interface, it can optionally be connected directly to the local multiplexed bus of 8051 because of the internal Address Latch function (via ALE). The Address lines A0 ... A6 must be wired externally to the data lines D0 ... D6 (direct connection) in this case. Since data transfer is controlled by interrupt, the DMA acknowledge inputs (\overline{DACKA} , \overline{DACKB}) are connected to V_{DD} .

1.6.2.2 ESCC2 with SAB 80188 Microprocessor

A system with minimized additional hardware expense can be build up with a SAB 80188 microprocessor as shown in **figure 7**.

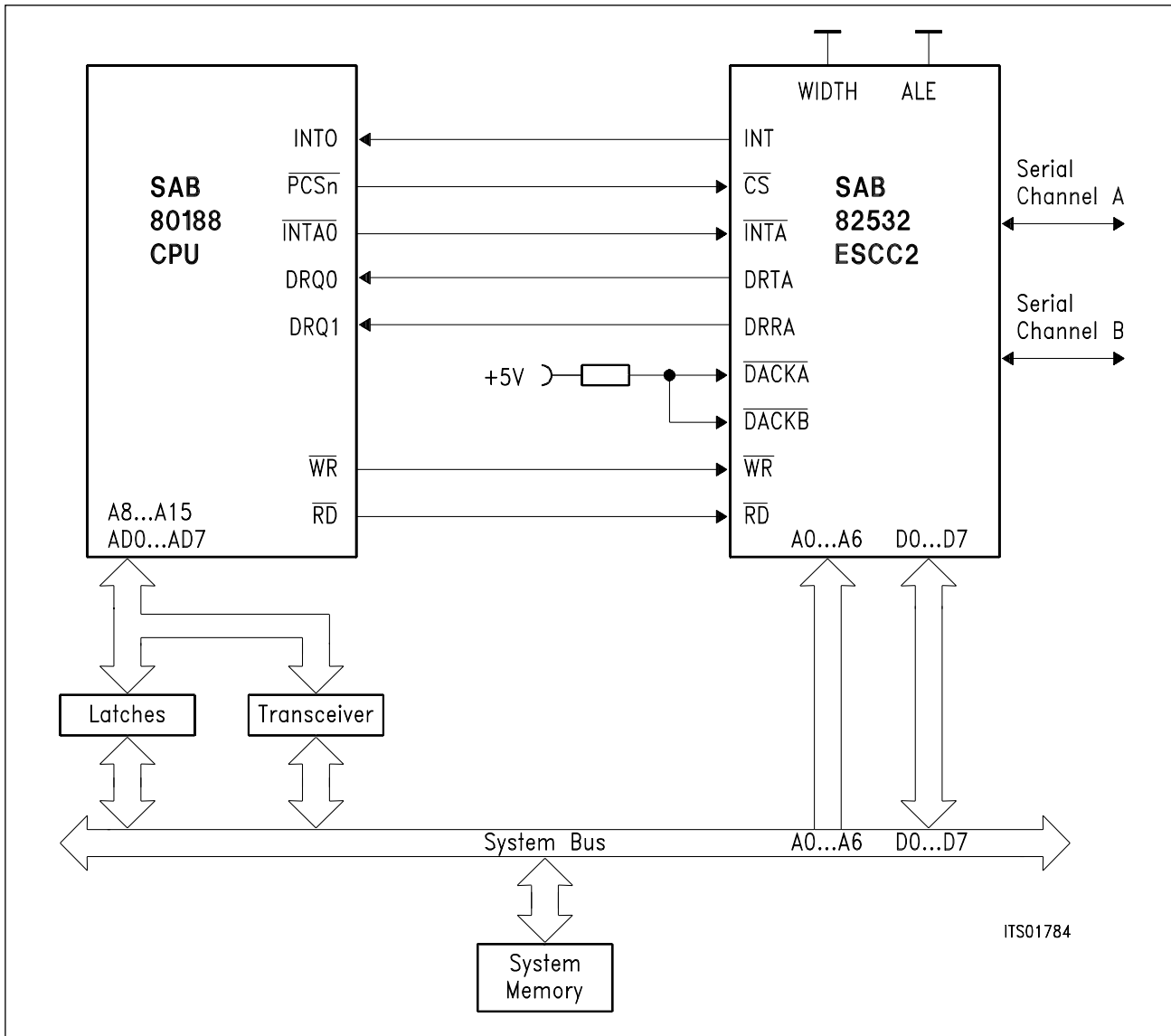

Figure 7
ESCC2 with SAB 80188 CPU

The ESCC2 is connected to the demultiplexed system bus. Data transfer for one serial channel can be done by the 2-channel on-chip DMA controller of the 80188, the other channel is serviced by interrupt. Since the 80188 does not provide DMA Acknowledge outputs, data transfer from/to ESCC2 is controlled via CS, RD or WR Address information (A0 ... A6) and the DACKA, DACKB inputs are not used.

This solution supports applications with a high speed data rate in one serial channel with minimum hardware expense making use of the on-chip peripheral functions of the 80188 (chip select logic, interrupt controller, DMA controller).

1.6.2.3 ESCC2 with SAB 80286 Microprocessor and SAB 82258 Advanced DMA Controller (ADMA)

In applications where two high-speed channels are required, a 16-bit system with 80286 CPU and 82258 Advanced DMA controller (ADMA) is suitable. This is shown in figure 8.

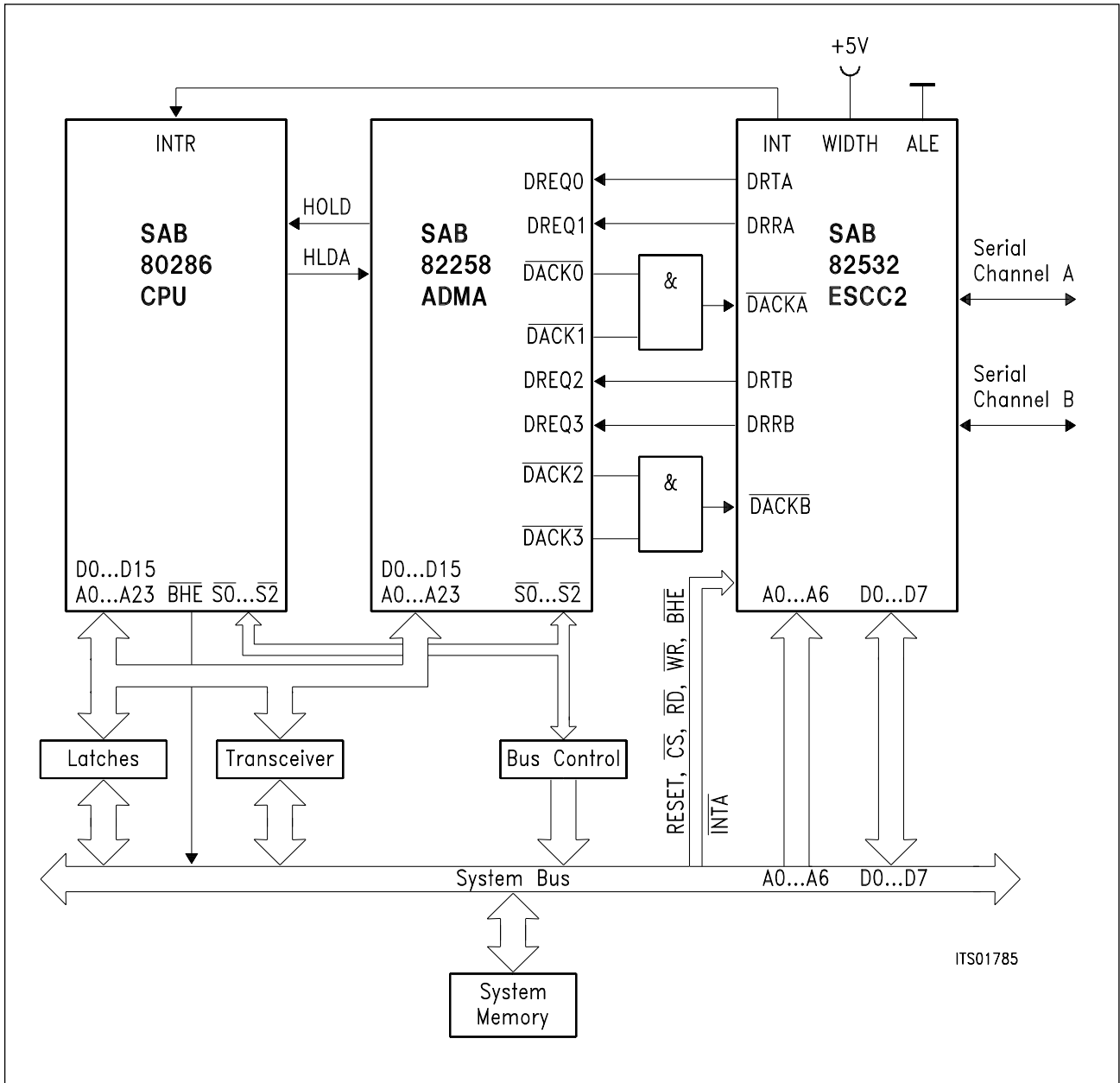

**Figure 8
ESCC2 with SAB 80286 CPU/SAB 82258 ADMA**

The four Selector Channels of ADMA are used for serving the four DMA Request sources of ESCC2, allowing very high data rates for both the system bus and the serial channels.

Introduction

Another significant advantage of the ADMA is its Data Chaining feature, providing an optimized memory management for receive and transmit data. Recording the ESCC2, a linked chain of 32 byte deep buffers can be set up, which are subsequently filled with the contents of the ESCC2's FIFOS during reception. Unused buffers can be saved and linked to another buffer chain reserved for the reception of the next frame.

As a result, it is not necessary to reserve a very large space in system memory, for example determined by the maximum frame length of every received frame.

In this example, the ADMA works directly on the CPU's local bus and shares the same bus interface logic (Address Latches, Transceivers, Bus Controller) with the 80286. Since one DMA Acknowledge line is provided for each DMA Request, two $\overline{\text{DACK}}_n$ outputs must be 'AND'ed together for input to the ESCC2.

The ESCC2's data lines (D0 ... D15) are connected to the system data bus and the address lines to A0 ... A6. Pin WIDTH has to be tied to V_{DD} to select the 16-bit interface mode of the ESCC2, pin ALE has to be fixed to V_{SS} to enable demultiplexed Intel bus interface.

1.6.2.4 ESCC2 with 80386 or SAB-R3000 (MIPS)

In high-performance 32-bit systems based on 80386 or SAB-R3000 microprocessors a separate control logic (e.g. sequencer PALs) is normally provided to generate all necessary control signals for interfacing to I/O devices. Address and data lines are buffered via latches or transceivers.

1.6.2.5 ESCC2 with MC 68008

Figure 9 gives an overview for connecting the ESCC2 to the Motorola type microprocessor MC 68008. Interfacing is very simple because most lines can be connected directly.

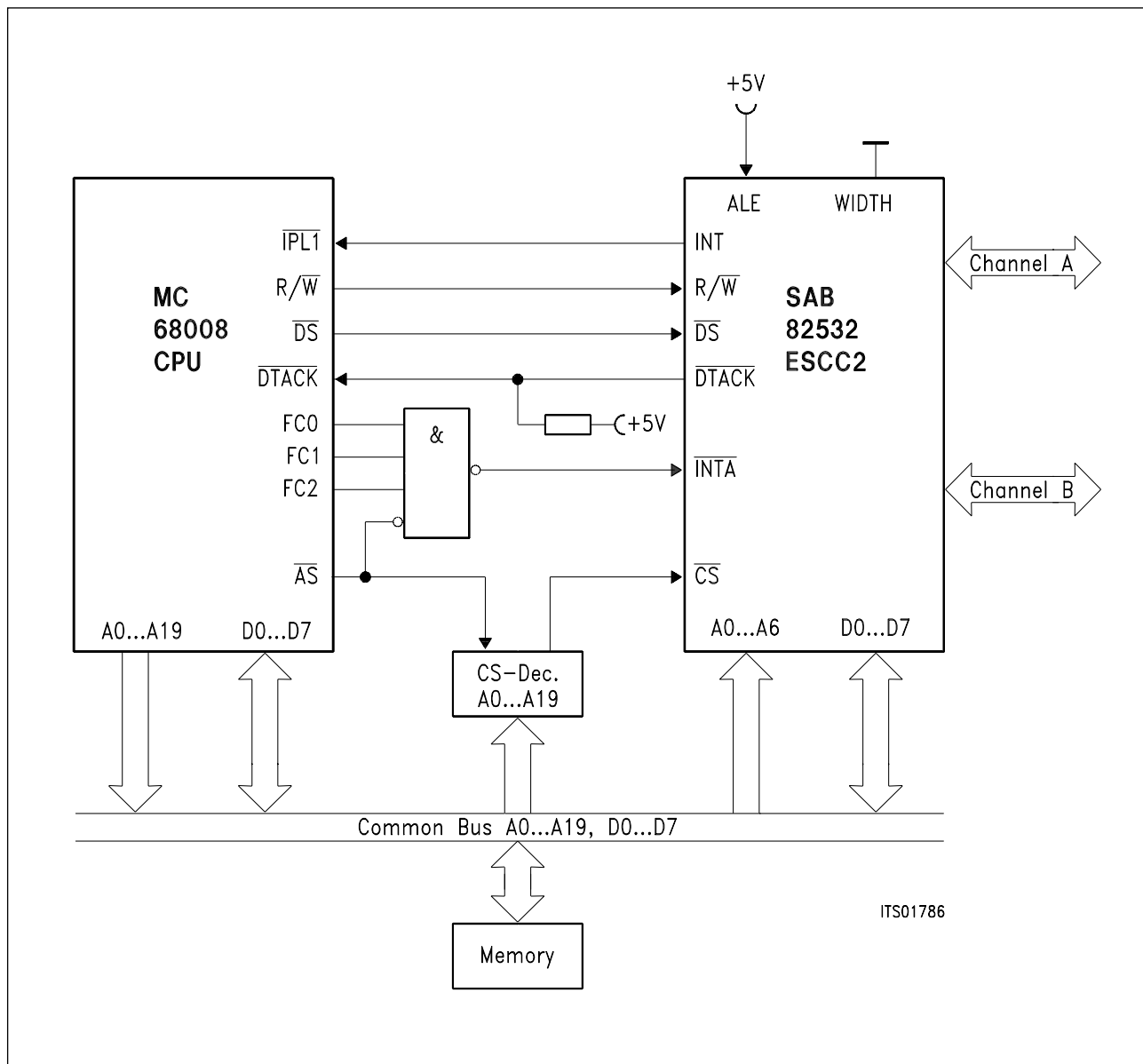

Figure 9
ESCC2 with MC 68008

1.6.2.6 ESCC2 with MC 68000, 68010, 68012

In these 16-bit systems the integration of some additional glue logic is necessary (refer to **figure 10**). The reason is that these microprocessors provide two different data strobe signals for low byte/high byte access and word/byte access via the data bus (no address line A0).

Note: The propagation delay of the selected AND gate has to be high enough to guarantee the specified address setup times.

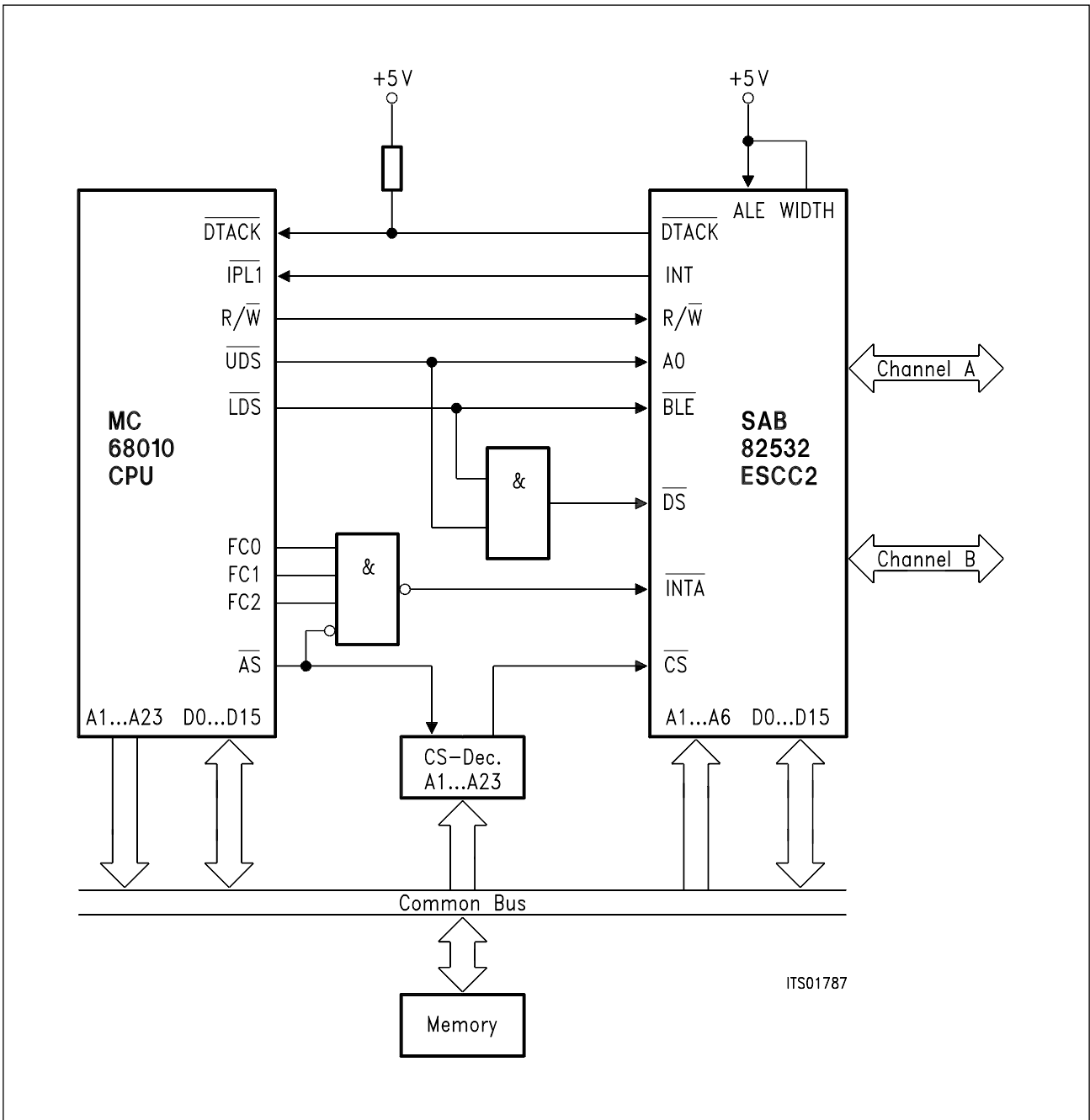

Figure 10
ESCC2 with MC 68010

1.6.2.7 ESCC2 with MC 68020, 68030

Figure 11 gives an example of interfacing to a 32-bit Motorola microprocessor. As for MC 68000, 68010 and 68012 microprocessors, some glue logic is necessary, too. The signal Bus Low Enable (\overline{BLE}) has to be decoded out of transfer size information (SIZ0, 1) and A0. The ESCC2 interface logic has to respond as a 16-bit peripheral (DSACK1, 0 = 01_H) during register access and interrupt acknowledge cycles.

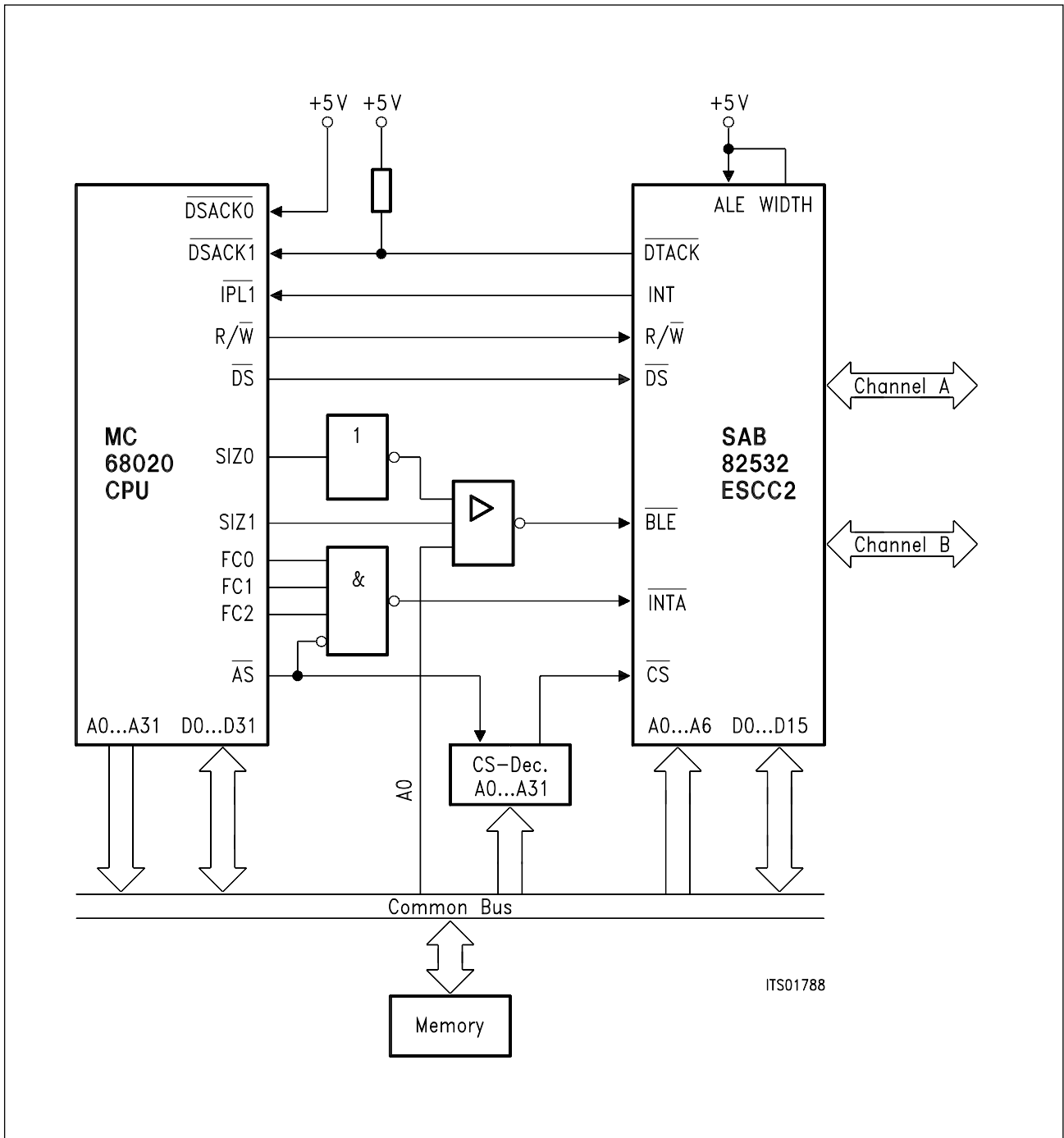

Figure 11
ESCC2 with MC 68020

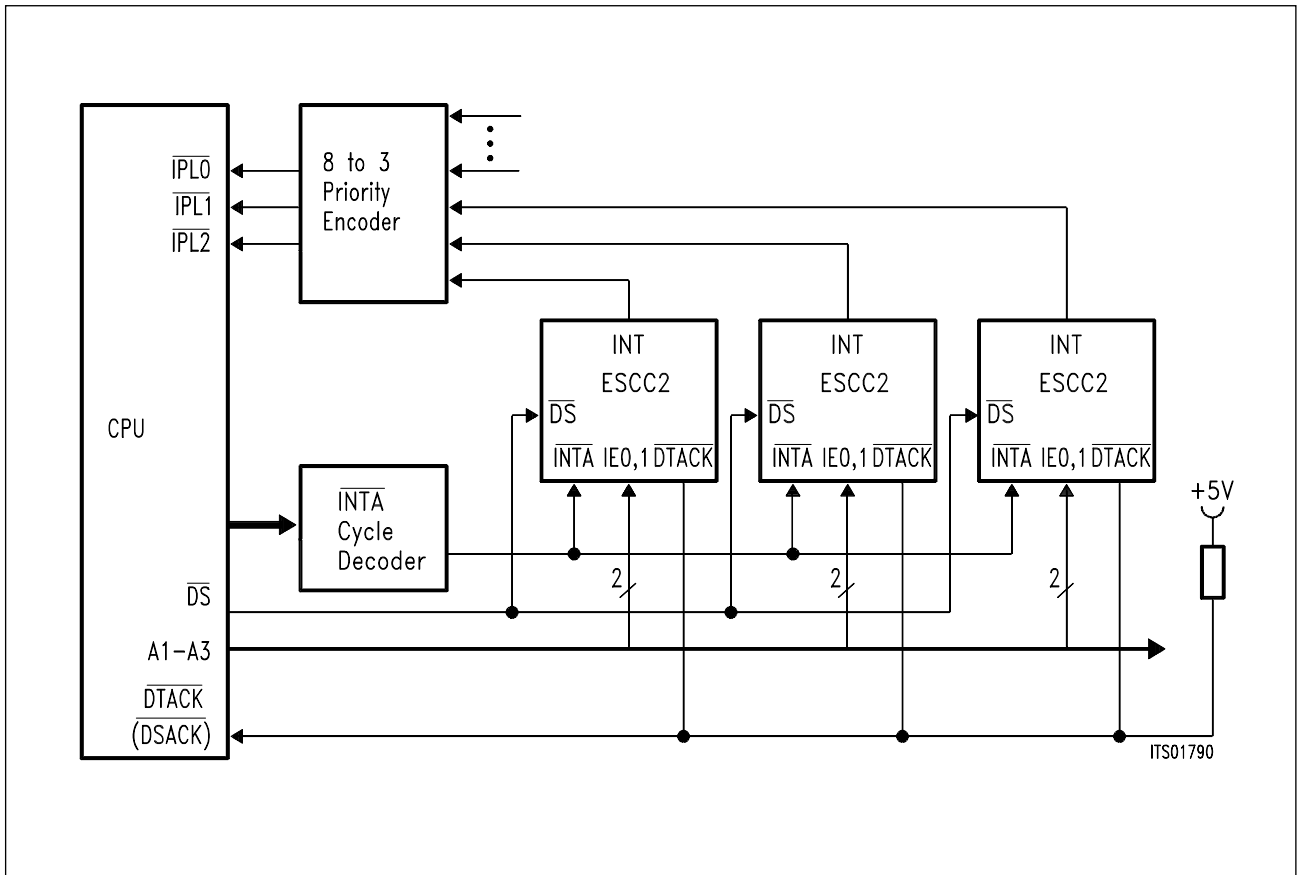

Figure 13
Interrupt Cascading (slave mode) in Motorola Bus Mode

Daisy Chaining

If selected via IPC register the Interrupt Enable pins IE0, IE1 are used for building a Daisy Chain by connecting the Interrupt Enable Output (IE0) of the higher priority device to the Interrupt Enable Input (IE1) of the lower priority device. The highest priority device has IE1 pulled high (refer to **figure 14** and **15**).

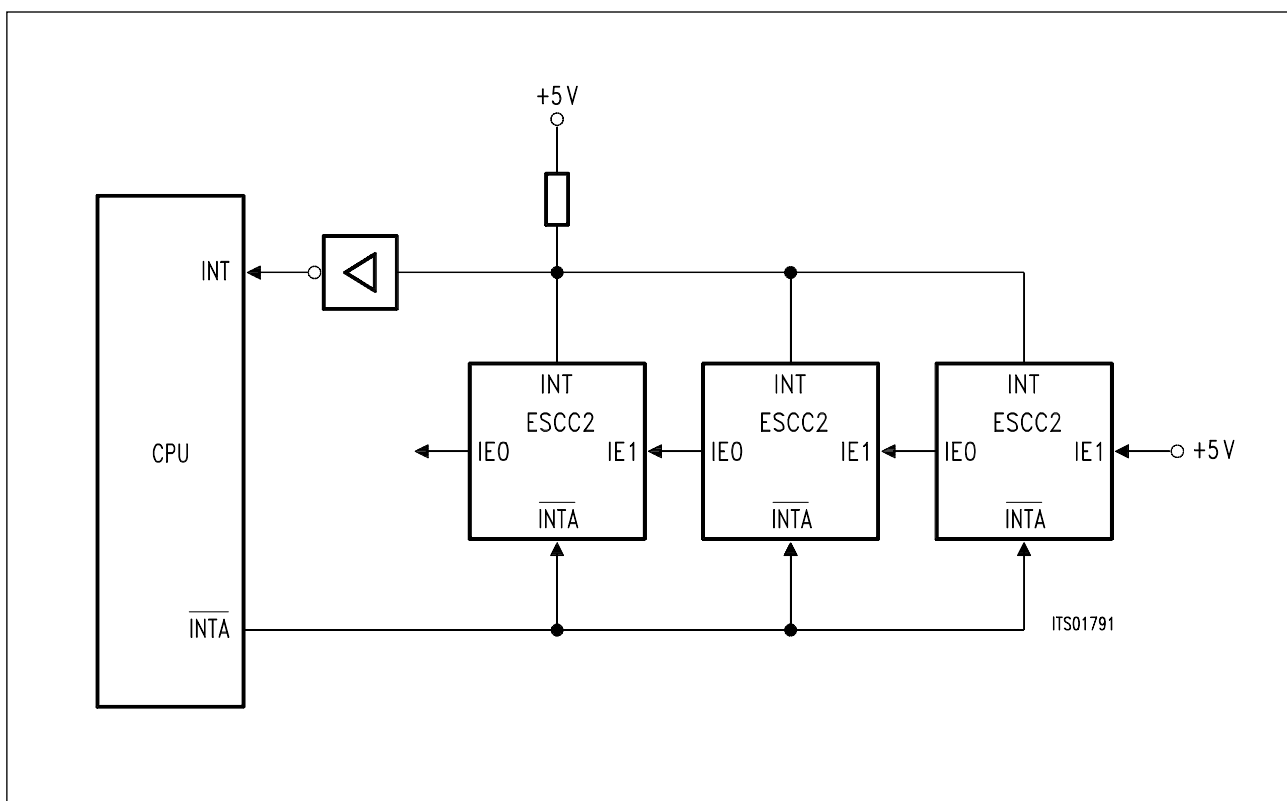

Figure 14
Interrupt Cascading (Daisy Chaining) in Intel Bus Mode

For Intel type microprocessor systems the 2-cycle interrupt acknowledge scheme is supported ('86 mode). Maximum available settling time for the chain: from the beginning of the first \overline{INTA} cycle to the beginning of the second.

2 Basic Functional Principles

2.1 General

The ESCC2 distinguishes itself from other communication controllers by its advanced characteristics. The most important are:

- Support of HDLC, SDLC, BISYNC/MONOSYNC and Asynchronous protocols
- Support of layer-2 functions (HDLC mode)
In addition to those bit-oriented functions commonly supported by HDLC controllers, such as bit stuffing, CRC check, flag and address recognition, the ESCC2 provides a high degree of procedural support.
- In a special operating mode (auto-mode), the ESCC2 processes the information transfer and the procedure handshaking (I- and S-frames of HDLC protocol) autonomously. The only restriction is that the window size (= number of outstanding unacknowledged frames) is limited to 1, which is sufficient for many applications. The communication procedures are mainly processed between the communication controllers and not between the attached processors. Thus the dynamic load on the CPU and the software expense is greatly reduced.
- The CPU is informed about the status of the procedure and has mainly to manage the receive and transmit data. In order to maintain cost effectiveness and flexibility, the handling of unnumbered (U) frames, and special functions such as error recovery in case of protocol errors, are not implemented in hardware and must be done by the user's software.
- Extended support of different link configurations
Besides the point-to-point configurations, the ESCC2 allows the implementation of point-to-multipoint or multi-master configurations without additional hardware or software expense.
In point-to-multipoint configurations, the ESCC2 can be used as a master or as a slave station. Even when working as slave station, the ESCC2 can initiate the transmission of data at any time. An internal function block provides means of idle and collision detection and collision resolution, which are necessary if several stations start transmitting simultaneously. Thus, a multi-master configuration is also possible.

Basic Functional Principles

– Telecom specific features

In a special operating mode, the ESCC2 can transmit or receive data packets in one of up to 64 time-slots of programmable width (clock mode 5). Furthermore, the ESCC2 can transmit or receive variable data portions within a defined window of one or more clock cycles in conjunction with an external strobe signal (clock mode 1). These features make the ESCC2 suitable for applications using time division multiplex methods, such as time-slot oriented PCM systems or systems designed for packet switching.

– FIFO buffers for efficient transfer of data packets

A further speciality of ESCC2 are the 64 byte deep FIFO buffers used for the temporary storage of data packets transferred between the serial communications interface and the parallel system bus. Because of the overlapping input/output operation (dual-port behaviour), the maximum message length is not limited by the size of the buffer. The dynamic load of the CPU is drastically reduced by transferring the data packets block by block via Direct Memory Access supported by the ESCC2. The CPU only has to initiate the data transmission by the ESCC2 and determine the status in case of completed reception, but is not involved in data transfers.

– The 16-bit wide microprocessor interface enables high data throughput and offers a high flexibility for connection to both 8/16-bit Siemens/Intel and Motorola type microprocessor systems. Moreover, interrupt driven systems are supported by vectorized interrupts and interrupt cascading capabilities.

Basic Functional Principles

Link Configurations

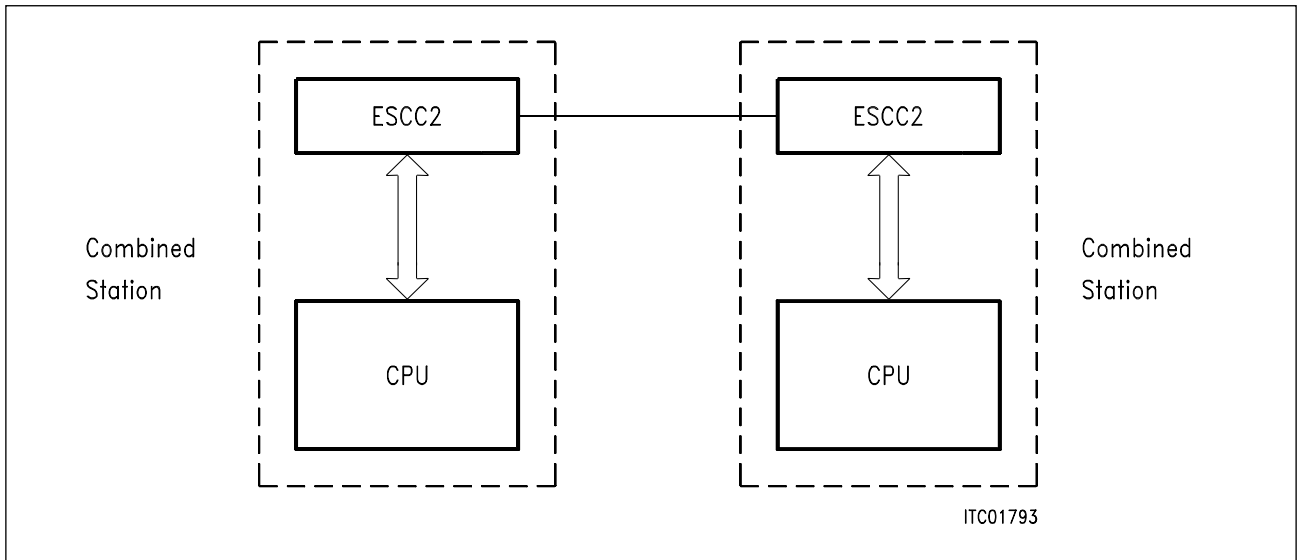

Figure 16a
Point-to-Point Configuration

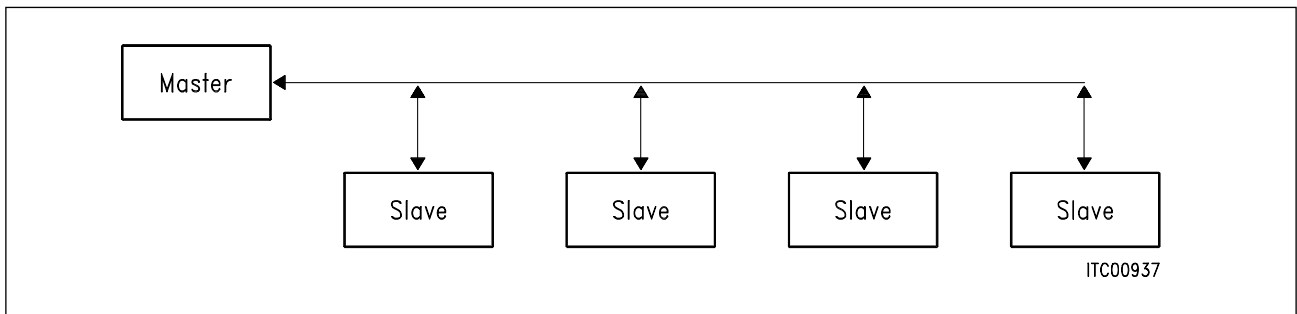

Figure 16b
Point-to-Multipoint Configuration

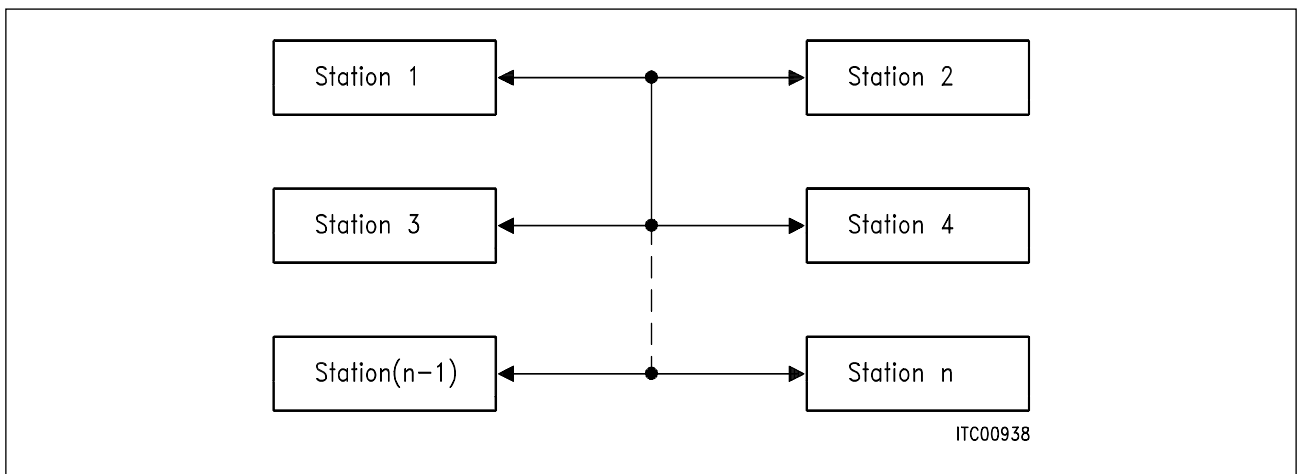

Figure 16c
Multimaster Configuration

Basic Functional Principles

2.2 FIFO Structure

In both transmit and receive direction 64-byte deep FIFO's are provided for the intermediate storage of data between the serial interface and the CPU interface. The FIFO's are divided into two halves of 32-bytes. Only one half is accessible to the CPU or DMA controller at any time.

Organization of the FIFOs and access to their contents depends on the selected serial mode. For detailed information, refer to description of RFIFO and XFIFO in chapters 10.1, 10.2 and 10.3. In case 16-bit data bus width is selected by fixing pin WIDTH to logical '1' word access to the FIFOs is enabled. Data output to bus lines D0 ... D15 as a function of the selected interface mode is shown in figure 20 and 21. Of course, byte access is also allowed.

The effective length of the accessible part of RFIFO can be changed from 32 bytes (RESET value) down to 1 (ASYNC and BiSYNC mode) or 2 (HDLC mode) bytes.

In version 1, only threshold 32 is available in HDLC mode.

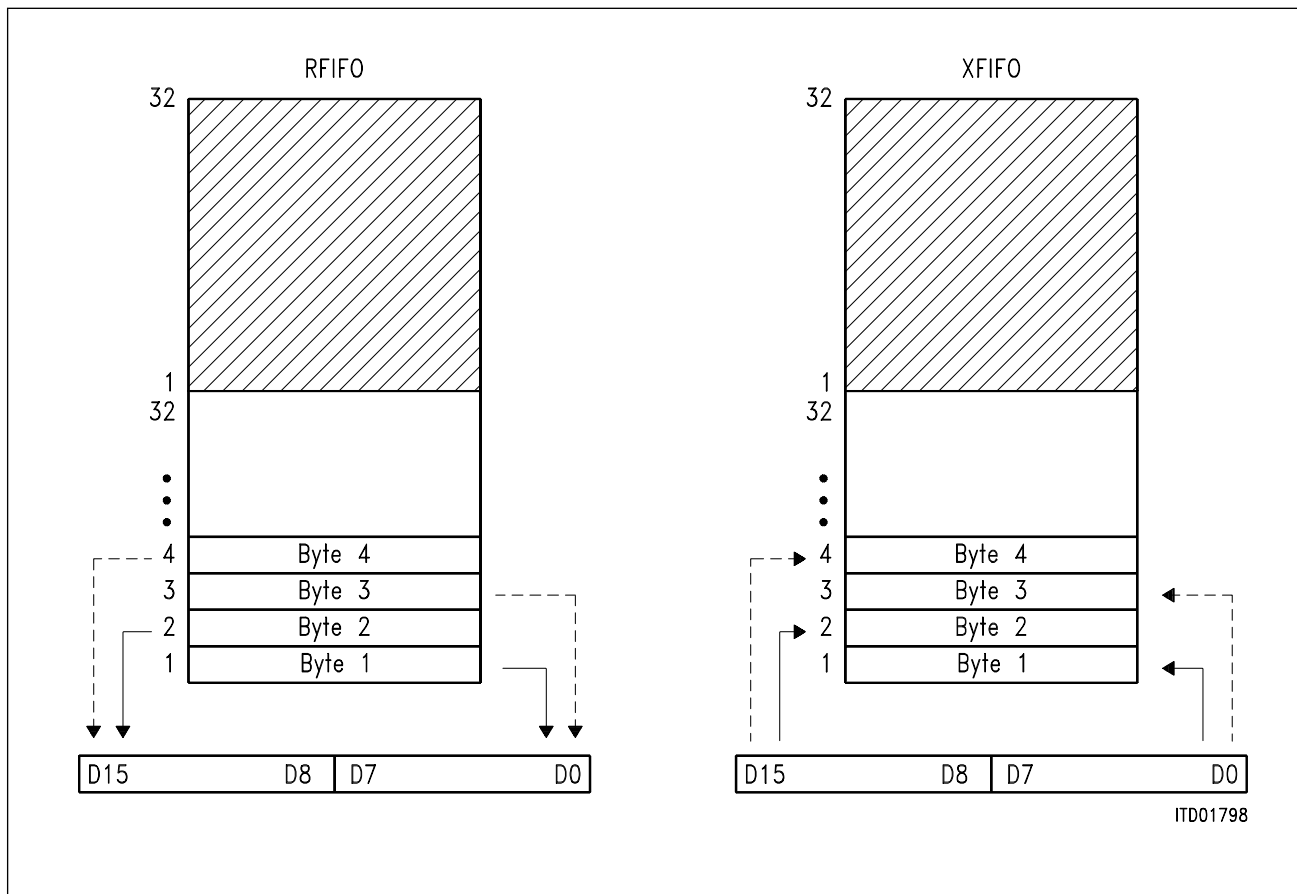

Figure 17
FIFO Word Access (Intel mode)

Basic Functional Principles

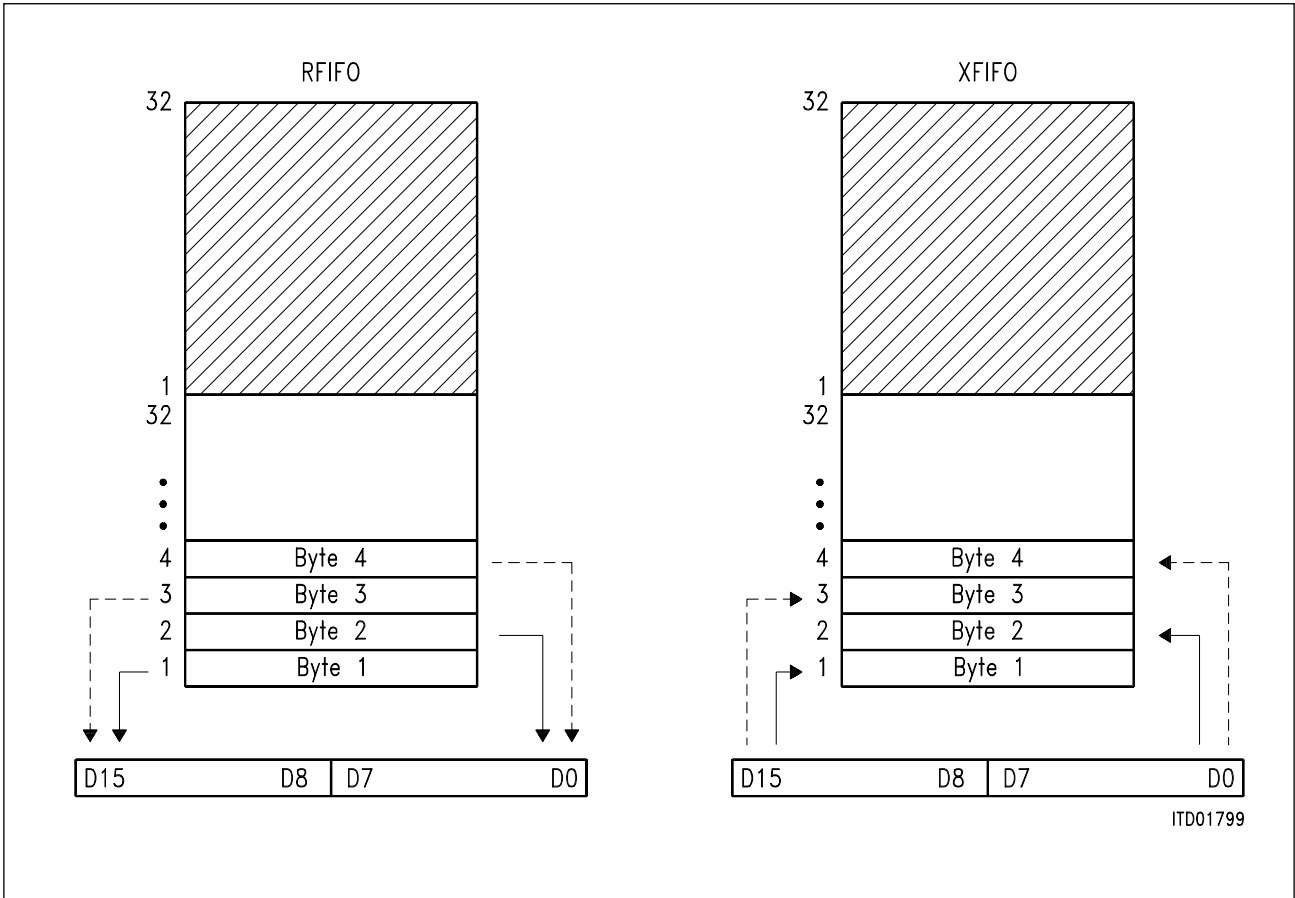

Figure 18
FIFO Word Access (Motorola mode)

3 Microprocessor Interface

3.1 Register Set

The communication between the CPU and the ESCC2 is done via a set of directly accessible registers. The interface may be configured as Siemens/Intel or Motorola type with a selectable data bus width of 8 or 16 bits.

The CPU transfers data to/from the ESCC2 (via 64 byte deep FIFOs per direction and channel), sets the operating modes, controls function sequences, and gets status information by writing or reading control/status registers. All accesses can be done as byte or word accesses if enabled. If 16-bit bus width is selected, access to lower/upper part of the data bus is determined by address line A0 and signal BHE/BL \bar{E} as shown in **table 1** and **2**.

Mixed Byte/Word Access to the FIFOs

Reading from or writing to the internal FIFOs (RFIFO and XFIFO of each channel) can be done using an 8-bit (byte) or 16-bit (word) access depending on the selected bus interface mode. In version 1 of ESCC2, byte access in the case of 16-bit bus interface mode is allowed if not mixed with word accesses when reading from or writing to the same pool.

In version 2.x upward randomly mixed byte/word access to the FIFOs is allowed with the restriction that in HDLC mode and BISYNC mode 32 bytes have to be written to the internal FIFO when only XTF (HDLC) command or XF (BISYNC) command is set afterwards. There is no restriction when XTF and XME (HDLC) or XF and XME (BISYNC) is set afterwards.

**Table 1
Data Bus Access (16-bit Intel mode)**

BHE	A0	Register Access	ESCC2 Data Pins Used
0	0	FIFO word access Register word access (even addresses)	D0 ... D15
0	1	Register byte access (odd addresses)	D8 ... D15
1	0	Register byte access (odd addresses)	D0 ... D7
1	1	No transfer performed	None

Microprocessor Interface

Table 2
Data Bus Access (16-bit Motorola mode)

BHE	A0	Register Access	ESCC2 Data Pins Used
0	0	FIFO word access Register word access (even addresses)	D0 ... D15
0	1	Register byte access (odd addresses)	D8 ... D15
1	0	Register byte access (odd addresses)	D0 ... D7
1	1	No transfer performed	None

The assignment of registers with even/odd addresses to the data lines in case of 16-bit register access depends on the selected microprocessor interface mode:

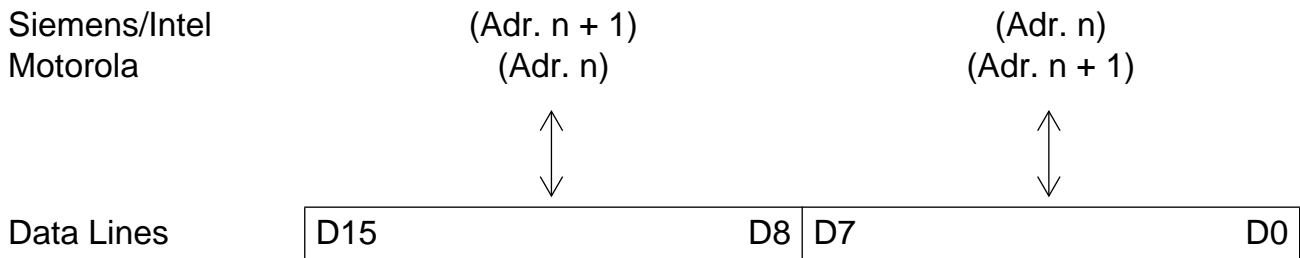

Complete information concerning register functions is provided in **chapter 10**. The most important functions programmable via these registers are:

- setting of serial, operating and clocking modes
- layer-2 functions
- data transfer modes (interrupt, DMA)
- bus mode
- DPLL mode
- baud rate generator
- test loop.

Each of the two serial channels of ESCC2 is controlled via an identical, but totally independent register set (channel A and channel B). Functions which are common to or independent from both channels, e.g. interrupt information or universal port programming, are accessible via both register sets, which simplifies software development.

Microprocessor Interface

3.2 Data Transfer Modes

Data transfer between the system memory and the ESCC2 for both transmit and receive direction is controlled by either interrupts (interrupt mode), or independently from CPU, using the ESCC2's 4-channel DMA interface (DMA mode).

After RESET, the ESCC2 operates in interrupt mode, where data transfer must be done by the CPU. The user selects the DMA mode by setting the DMA bit in the XBCH register. Both channels can be independently operated in either interrupt or DMA mode (e.g. channel A: DMA, channel B: interrupt).

3.3 Interrupt Interface

Special events in the ESCC2 are indicated by means of a single interrupt output with programmable characteristics (open drain, push-pull; IPC register), which requests the CPU to read status information from the ESCC2, or, if interrupt mode is selected, to transfer data from/to ESCC2.

Since only one INT request output is provided, the cause of an interrupt must be determined by the CPU

- by evaluating the interrupt vector which is generated by ESCC2 during an interrupt acknowledge cycle, and/or
- by reading the ESCC2's interrupt status registers (GIS, ISR0, ISR1, PIS).

The structure of the interrupt status registers is shown in **figure 19**.

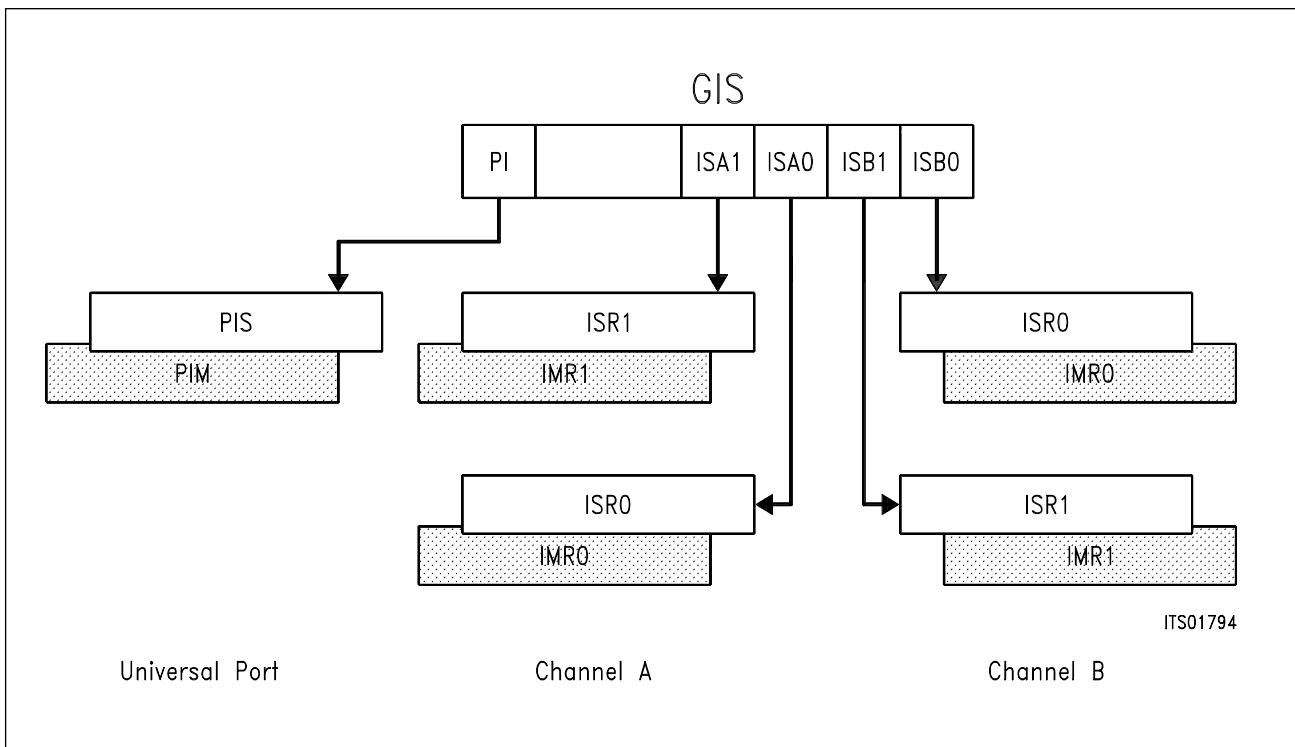

Figure 19
ESCC2 Interrupt Status Registers

Microprocessor Interface

Each interrupt indication of registers ISR0, ISR1 and PIS can be selectively masked by setting the corresponding bit in the corresponding mask registers IMR0, IMR1 and PIM. Use of these registers depends on the selected serial mode. GIS, the non-maskable Global Interrupt Status Register serves as pointer to pending channel related interrupts and universal port interrupts.

Interrupt Polling

After ESCC2 has requested an interrupt by activating its INT pin, the CPU must first read the Global Interrupt Status Register GIS to identify registers with active interrupt indications. Reading these registers will reset all activated bits and the corresponding indication in GIS. If all interrupts are acknowledged (GIS is reset), pin INT goes inactive.

Vectorized Interrupt Structure

After ESCC2 has requested an interrupt by activating its INT pin, the system (CPU or peripherals) starts the interrupt acknowledge cycle by activating the INTA signal. If the Intel bus interface mode is selected, the two-pulse '86 mode is supported. In Motorola interface mode single pulse acknowledgement is implemented.

Interrupt acknowledge operation is determined by the selected interrupt cascading mode (IPC register) in conjunction with the Interrupt Enable Signals IE0 and IE1 (refer to **chapter 1.3, 1.6, and 10**):

– Slave Mode

The address of the slave under service has to be provided via inputs IE0 and IE1 during the valid INTA cycle. Interrupt acknowledge is accepted if this address corresponds to the programmed value (IPC register).

If the ESCC2 is used in single device applications (no other device is present for interrupt cascading), IE0 and IE1 have to be fixed to a defined level corresponding to the internally programmed address.

– Daisy Chaining Mode

IE0 as Interrupt Enable Output and IE1 as Interrupt Enable Input are used to build a Daisy Chain (refer to **chapter 1.6**). Interrupt acknowledge is accepted if IE1 is active during the valid INTA cycle. Output IE0 follows the IE1 input. Additionally, IE0 is reset when INT goes active. During INTA cycles activation of pin INT is prohibited.

If interrupt acknowledge is accepted in one of the above modes, the ESCC2 generates an interrupt vector which is output on D0-D7 of the data bus independent of the selected bus interface mode. All interrupt sources are organized in 8 groups with fixed priority (refer to **figure 20**).

Masked Interrupts Visible in Status Registers (version 2 upward)

The interrupt vector contains only one interrupt at a time: the interrupt displayed in this vector results from a priority resolution among all **unmasked** active interrupt statuses. The Global Interrupt Status register (GIS) points to all interrupt status registers with active interrupt indications. Register GIS should be evaluated if a pure interrupt polling scheme is used or if interrupt group 7 or 8 is indicated in the generated interrupt vector.

In version 1 of ESCC2 only unmasked interrupt statuses may:

- generate an interrupt at pin INT,
- generate an interrupt vector,
- be visible in GIS, and
- be visible in the interrupt status registers ISR0_A ... B, ISR1_A ... B and PIS.

Masked interrupt statuses are only stored internally and they become visible when the mask is withdrawn.

In version 2 upward, an additional mode can be selected via bit IPC:VIS.

In this mode, masked interrupt status bits still neither generate an interrupt at pin INT nor generate an interrupt vector nor are visible in GIS, **but are displayed in the respective interrupt status register(s) ISR0_A..B, ISR1_A..B and PIS.**

This mode is useful when some interrupt status bits are to generate an interrupt vector and other status bits are to be polled in the individual interrupt status registers.

Note 1: In the visible mode, all active interrupt status bits, whether the corresponding actual interrupt is masked or not, are reset when the interrupt status register is read. Thus, when polling of some interrupt status bits is desired, care must be taken that unmasked interrupts are not lost in the process.

Note 2: All unmasked interrupt statuses are treated as before.

Note 3: Please note that whenever polling is used, all interrupt status registers concerned have to be polled individually (no 'hierarchical' polling possible), since GIS only contains information on actually generated – i.e. unmasked interrupts.

4 DMA Interface

The ESCC2 comprises a 4-channel DMA interface for fast and efficient data transfers. For both serial channels, a separate DMA Request output for transmit (DRT) and receive direction (DRR) as well as a DMA Acknowledgement (\overline{DACK}) input is provided.

The ESCC2 activates the DMA Request line as long as data transfers are needed from/to the specific FIFO (level triggered demand transfer mode of DMA controller).

It is the responsibility of the DMA controller to perform the correct amount of bus cycles. Either read cycles will be performed if the DMA transfer has been requested from the receiver, or write cycles if DMA has been requested from the transmitter. If the DMA controller provides a DMA acknowledge signal (input to the ESCC2's \overline{DACK} pin), each bus cycle implicitly selects the top of the specific FIFO and neither address (via A0 ... A6) nor chip select need to be supplied (I/O to memory transfers). If no \overline{DACK} signal is supplied, normal read/write operations (with addresses) must be performed (memory to memory transfers). The ESCC2 deactivates the DMA Request line immediately after the last read/write cycle of the data transfer has started.

As a very useful feature for single cycle DMA transfers, optional inversion of the functions of read/write control lines is implemented. If programmed via register CCR2

- \overline{RD} and \overline{WR} are exchanged in Intel bus interface mode,
- $\overline{R/W}$ is inverted in Motorola bus interface mode

while \overline{DACK} is active. This allows easy connection to DMA controllers without dedicated I/O control lines as shown in **figure 21**.

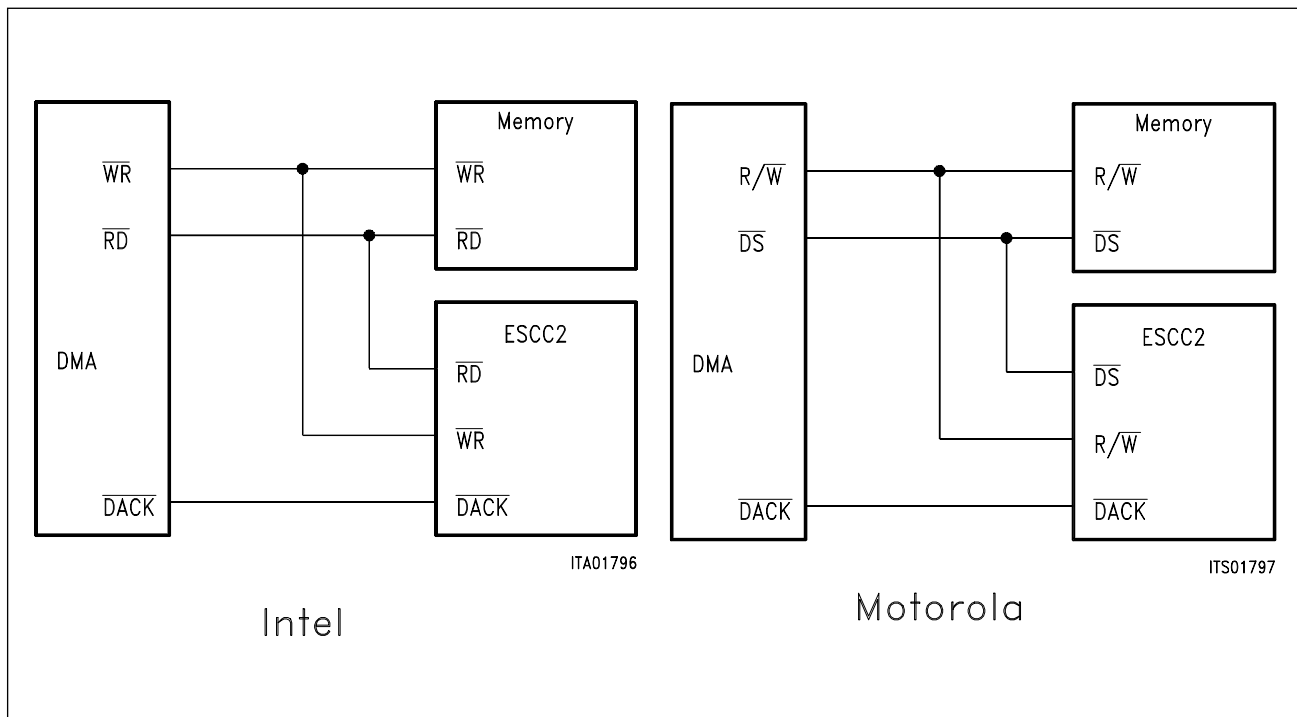

Figure 21
DMA Interfacing by Using Invert Mode

5 HDLC/SDLC Serial Mode

5.1 Operating Modes

The HDLC controller of each channel can be programmed to operate in various modes, which are different in the treatment of the HDLC frame in receive direction. Thus, the receive data flow and the address recognition features can be performed in a very flexible way, to satisfy almost any practical requirements.

There are 6 different operating modes which can be set via the MODE register.

Auto-Mode (MODE: MDS1, MDS0 = '00')

Characteristics: Window size 1, random message length, address recognition.

The ESCC2 processes autonomously all numbered frames (S-, I-frames) of an HDLC protocol. The HDLC control field, data in the I-field of the frames and an additional status byte are temporarily stored in the RFIFO. The HDLC control field as well as additional information can also be read from special registers (RHCR, RSTA).

Depending on the selected address mode, the ESCC2 can perform a 2-byte or 1-byte address recognition. If a 2-byte address field is selected, the high address byte is compared with the fixed value FE_H or FC_H (group address) as well as with two individually programmable values in RAH1 and RAH2 registers. According to the ISDN LAPD protocol, bit 1 of the high byte address will be interpreted as COMMAND/RESPONSE bit (C/R), dependent on the setting of the CRI bit in RAH1, and will be excluded from the address comparison.

Similarly, two comparison values can be programmed in special registers (RAL1, RAL2) for the low address byte. A valid address will be recognized in case the high and low byte of the address field correspond to one of the compare values. Thus, the ESCC2 can be called (addressed) with 6 different address combinations, however, only the logical connection identified through the address combination RAH1, RAL1 will be processed in the auto-mode, all others in the non auto-mode. HDLC frames with address fields that do not match any of the address combinations, are ignored by the ESCC2.

In the case of a 1-byte address, RAL1 and RAL2 will be used as comparison registers. According to the X.25 LAPB protocol, the value in RAL1 will be interpreted as COMMAND and the value in RAL2 as RESPONSE.

In version 2 and upwards the address bytes can be masked to allow selective broadcast frame recognition. For further information see **chapter 5.4.10**.

Non-Auto-Mode (MODE: MDS1, MDS0 = '01')

Characteristics: address recognition, arbitrary window size.

All frames with valid addresses (address recognition identical to auto-mode) are forwarded directly via the RFIFO to the system memory.

The HDLC control field, data in the I-field and an additional status byte are temporarily stored in the RFIFO. The HDLC control field and additional information can also be read from special registers (RHCR, RSTA).

In non-auto-mode, all frames with a valid address are treated similarly.

In version 2 upward the address bytes can be masked to allow selective broadcast frame recognition. For further information see **chapter 5.4.10**.

Transparent Mode 1 (MODE: MDS1, MDS0, ADM = '101')

Characteristics: address recognition high byte

Only the high byte of a 2-byte address field will be compared. The address byte is compared with the fixed value FE_H or FC_H (group address) as well as with two individually programmable values in RAH1 and RAH2 registers. The whole frame excluding the first address byte will be stored in RFIFO. RAL1 contains the second and RHCR the third byte following the opening flag.

In version 2 upward the address bytes can be masked to allow selective broadcast frame recognition. For further information see **chapter 5.4.10**.

Transparent Mode 0 (MODE: MDS1, MDS0, ADM = '100')

Characteristics: no address recognition

No address recognition is performed and each frame will be stored in the RFIFO. RAL1 contains the first and RHCR the second byte following the opening flag.

Extended Transparent Modes 0, 1 (MODE: MDS1, MDS0 = '11')

Characteristics: fully transparent

In extended transparent modes, fully transparent data transmission/reception without HDLC framing is performed, i.e. without FLAG generation/recognition, CRC generation/check, or bit stuffing. This allows user specific protocol variations.

Data transmission is always performed out of the XFIFO. In extended transparent mode 0 (ADM = '0'), data reception is done via the RAL1 register, which always contains the current data byte assembled at the RxD pin. In extended transparent mode 1 (ADM = '1'), the receive data are additionally shifted into the RFIFO.

Transmit Data Flow

Two different types of frames can be transmitted:

- I-frames and
- transparent frames

as shown below.

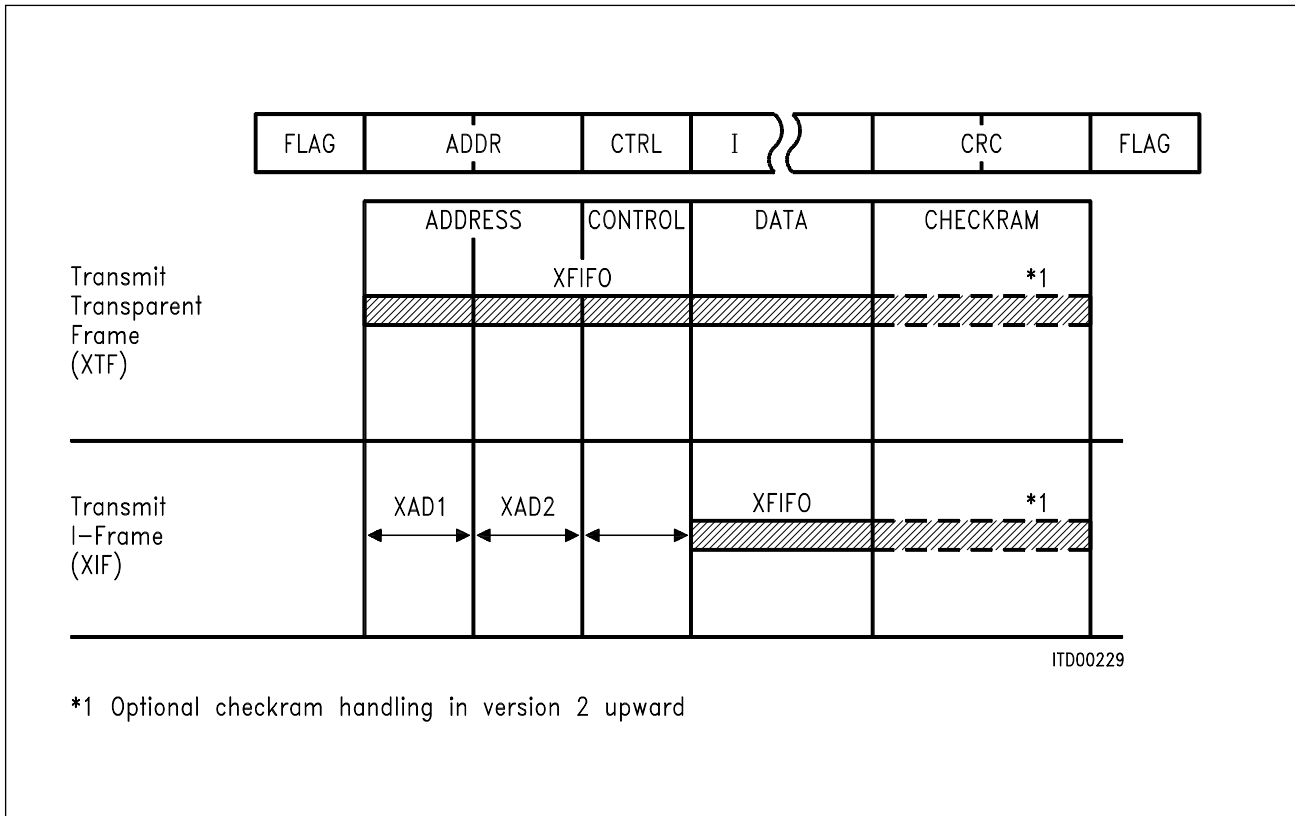

Figure 23
Transmit Data Flow of ESCC2

For I-frames (command XIF via CMDR register), the address and control fields are generated autonomously by the ESCC2 and the data in the XFIFO is entered into the information field of the frame. This is possible only if the ESCC2 is operated in the automode.

For transparent frames (command XTF via CMDR register), the address and the control fields have to be entered in the XFIFO as well. This is possible in all operating modes and used also in auto-mode for sending U-frames.

Version 2 upward:

If CCR3:XCRC is set, the CRC checksum will not be generated internally. The checksum has to be provided via the transmit FIFO (XFIFO) as the last two or four bytes. The transmitted frame will be closed automatically only with a (closing) flag.

Note: The ESCC2 does not check whether the length of the frame, i.e. the number of bytes, to be transmitted makes sense or not.

5.2 Procedural Support (layer-2 functions)

When operating in the auto mode, the ESCC2 offers a high degree of protocol support. In addition to address recognition, the ESCC2 autonomously processes all (numbered) S- and I-frames (prerequisite window size 1) with either normal or extended control field format (modulo-8 or modulo-128 sequence numbers – selectable via RAH2 register).

The following functions will be performed:

- updating of transmit and receive counter
- evaluation of transmit and receive counter
- processing of S commands
- flow control with RR/RNR
- generation of responses
- recognition of protocol errors
- transmission of S commands, if acknowledgement is not received
- continuous status query of remote station after RNR has been received
- programmable timer/repeater functions.

In addition, all unnumbered frames are forwarded directly to the processor. The logical link can be initialized by software at any time (Reset HDLC Receiver, RHR command). Additional logical connections can be operated in parallel by software.

5.2.1 Full-Duplex LAPB/LAPD Operation

Initially (i.e. after RESET), the LAP controllers of the two serial channels are configured to function as a combined (primary/secondary) station, where they autonomously perform a subset of the balanced X.25 LAPB/ISDN LAPD protocol.

Reception of Frames

The logical processing of received S-frames is performed by the ESCC2 without interrupting the CPU. The CPU is merely informed by interrupt of status changes in the remote station (receiver ready / receiver not ready) and protocol errors (unacceptable N(R), or S-frame with I field).

I-frames are also processed autonomously and checked for protocol errors. The I-frame will not be accepted in the case of sequence errors (no interrupt is forwarded to the CPU), but is immediately confirmed by an S-response. If the CPU sets the ESCC2 into a 'receive not ready' status, an I-frame will not be accepted (no interrupt) and an RNR response is transmitted. U-frames are always stored in the RFIFO and forwarded directly to the CPU. The logical sequence and the reception of a frame in auto mode is illustrated in **figure 24**.

Note: The state variables $N(S)$, $N(R)$ are evaluated within the window size 1, i.e. the ESCC2 checks only the least significant bit of the receive and transmit counter regardless of the selected modulo count.

Transmission of Frames

The ESCC2 autonomously transmits S commands and S responses in the auto mode. Either transparent or I-frames can be transmitted by the user. The software timer has to be operated in the internal timer mode to transmit I-frames. After the frame has been transmitted, the timer is self-started, the XFIFO is inhibited, and the ESCC2 waits for the arrival of a positive acknowledgement. This acknowledgement can be provided by means of an S- or I-frame.

If no positive acknowledgement is received during time t_1 , the ESCC2 transmits an S-command ($p = '1'$), which must be answered by an S-response ($f = '1'$). If the S-response is not received, the process is performed $n1$ times (in HDLC known as N2, refer to register TIMR).

Upon the arrival of an acknowledgement or after the completion of this poll procedure the XFIFO is enabled and an interrupt is generated. Interrupts may be triggered by the following:

- message has been positively acknowledged (ALLS interrupt)
- message must be repeated (XMR interrupt)
- response has not been received (TIN interrupt).

Additionally, XPR interrupts are generated which indicate that new data can be written to the XFIFO. Using XPR enables high data rates, e.g. in conjunction with back-to-back frames or shared flags.

In automode, however, only when the ALLS interrupt has been issued data of a new frame may be written to the XFIFO!

Upon arrival of an RNR frame, the software timer is started and the status of the remote station is polled periodically after expiration of t_1 , until the status 'receive ready' has been detected. The user is informed via the appropriate interrupt. If no response is received after $n1$ times, a TIN interrupt, and t_1 clock periods thereafter an ALLS interrupt is generated and the process is terminated.

Note: The internal timer mode should only be used in the auto mode.

Transparent frames can be transmitted in all operating modes. After the transmission of a transparent frame the XFIFO is immediately released, which is confirmed by interrupt (XPR). In this case, time monitoring can be performed with the timer in the external timer mode.

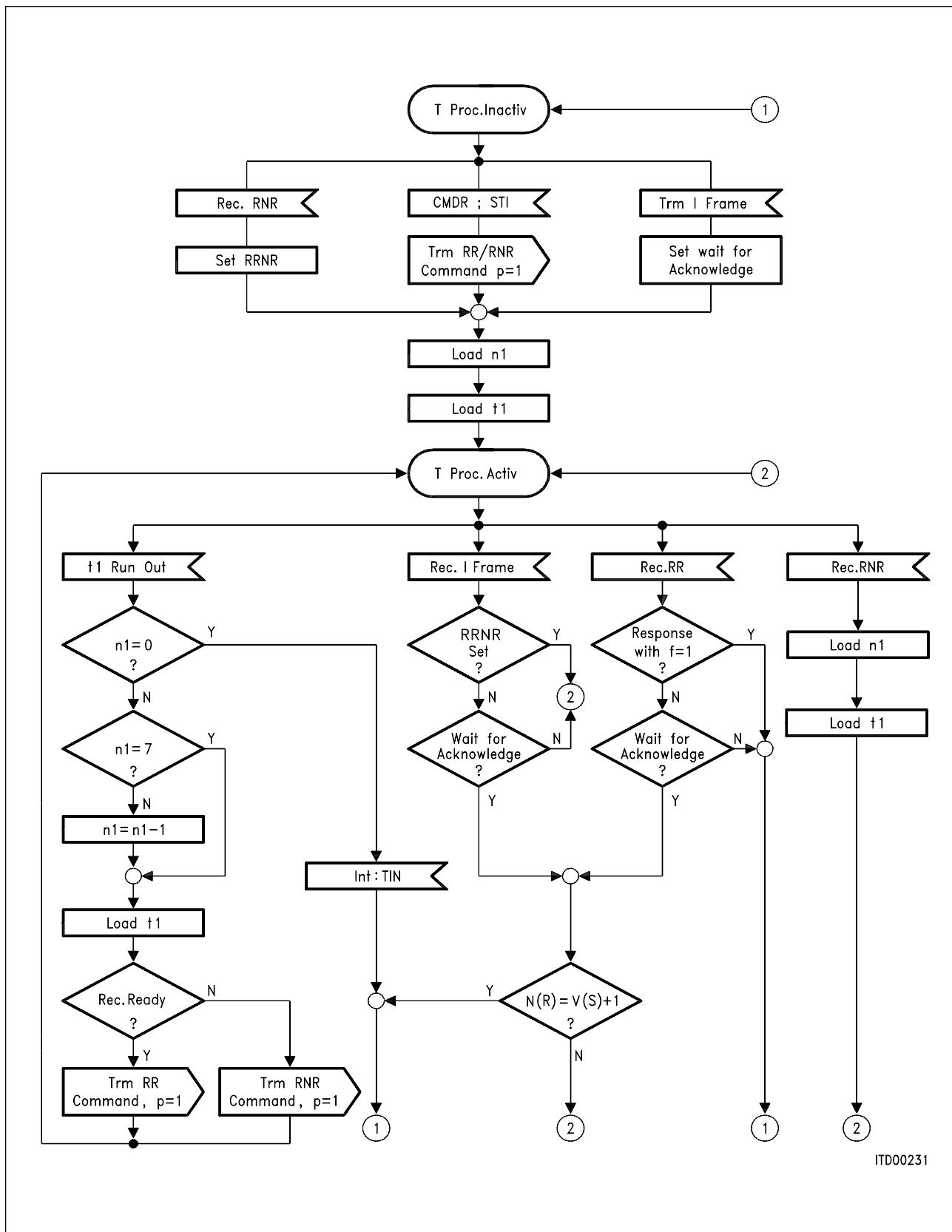

ITD00231

Figure 25
Timer Procedure/Poll Cycle

HDLC/SDLC Serial Mode

Examples

The interaction between ESCC2 and the CPU during transmission and reception of I-frames is illustrated in **figure 26a**, the flow control with RR/RNR during reception of I-frames in **figure 26b**, and during transmission of I-frames in **figure 27a**. Both, the sequence of the poll cycle and protocol errors are shown in **figure 27b**.

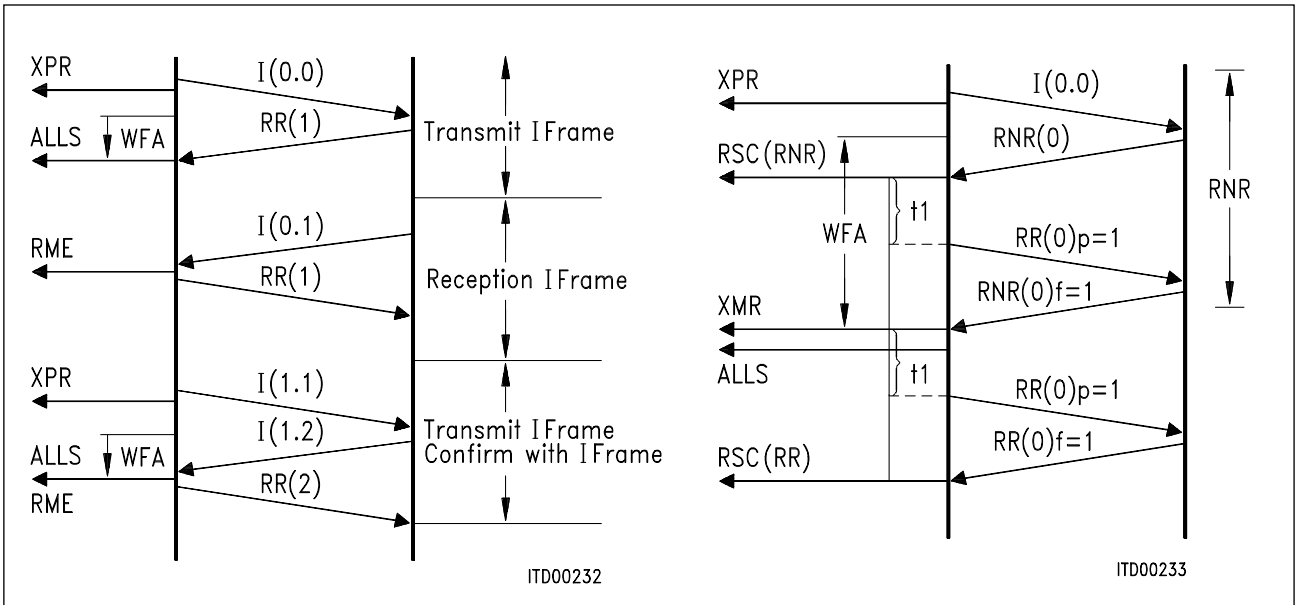

Figure 26a
Transmission/Reception I-Frames

Figure 26b
Flow Control/Transmission

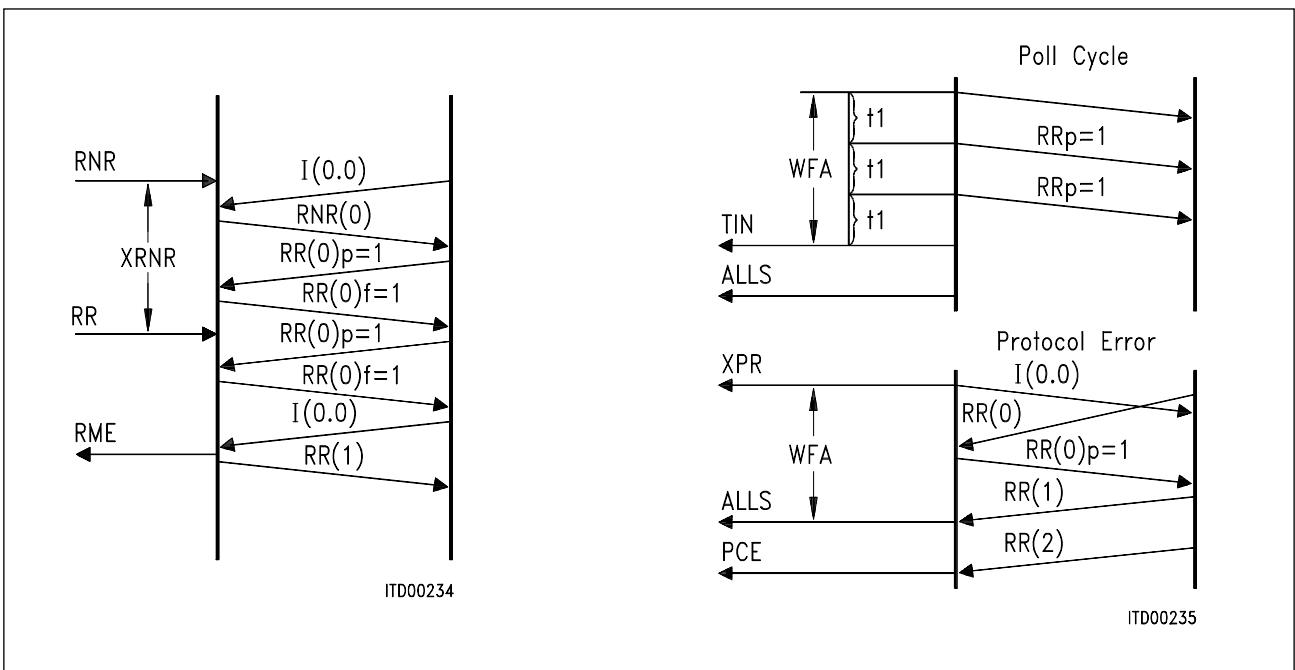

Figure 27a
Flow Control/Reception

Figure 27b
S-Commands/Protocol Error

5.2.2 Half-Duplex SDLC-NRM Operation

The LAP controllers of the two serial channels can be configured to function in a half-duplex Normal Response Mode (NRM), where they operate as a slave (secondary) station, by setting the NRM bit in the XBCH register of the corresponding channel.

In contrast to the full-duplex LAP B/LAP D operation, where the combined (primary + secondary) station transmits both commands and responses and may transmit data at any time, the NRM mode allows only responses to be transmitted **and** the secondary station may transmit only when instructed to do so by the master (primary) station. The ESCC2 gets the permission to transmit from the primary station via an S-, or I-frame with the poll bit (p) **set**.

The NRM mode can be profitably used in a point-to-multipoint configuration with a fixed master-slave relationship, which guarantees the absence of collisions on the common transmit line. It is the responsibility of the master station to poll the slaves periodically and to handle error situations.

Prerequisite for NRM operation is:

- auto mode with 8-bit address field selected
MODE: MDS1, MDS0, ADM = '000'
- external timer mode
MODE: TMD = '0'
- same transmit and receive addresses, since only responses can be transmitted, i.e.
XAD1 = XAD2 = RAL1 = RAL2 (address of secondary).

*Note: The broadcast address may be programmed in RAL2 if broadcasting is required.
In this case RAL1 and RAL2 are not equal.*

The primary station has to operate in transparent SDLC mode.

Reception of Frames

The reception of frames functions similarly to the LAPB/LAPD operation (see **chapter 5.2.1**).

Transmission of Frames

The ESCC2 does **not** transmit S-, or I-frames if not instructed to do so by the primary station via an S-, or I-frame with the poll bit set.

The ESCC2 can be prepared to send an I-frame by the CPU by issuing an XIF command (via CMDR) at any time. The transmission of the frame, however, will not be initiated by the ESCC2 until reception of either an

- RR, or
- I-frame

with a poll bit set ($p = '1'$).

After the frame has been transmitted (with the final bit set), the XFIFO is inhibited and the ESCC2 waits for the arrival of a positive acknowledgement.

Since the on-chip timer of the ESCC2 must be operated in the external mode (a secondary may not poll the primary for acknowledgements), timer supervision must be done by the primary station.

Upon the arrival of an acknowledgement the XFIFO is enabled and an interrupt is forwarded to the CPU, either the

- message has been positively acknowledged (ALLS interrupt), or the
- message must be repeated (XMR interrupt).

Additionally, the timer can be used **under CPU control** to provide timer recovery of the secondary if no acknowledgements are received at all.

Note: The transmission of transparent frames is only possible if the permission to send is given by an S-frame ($p = '1'$) or I-frame.

HDLC/SDLC Serial Mode

Examples

A few examples of ESCC2/CPU interaction in the case of NRM mode are shown in figure 28a to figure 29b.

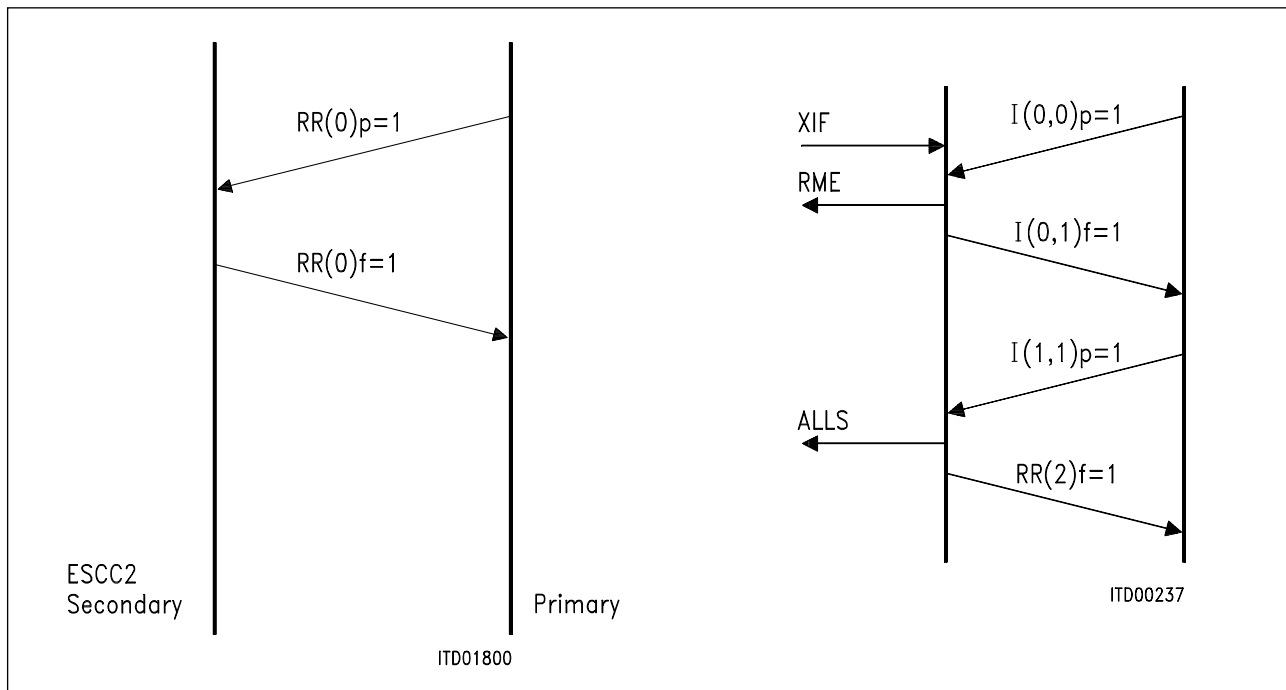

Figure 28a
No Data to Send

Figure 28b
Data Reception/Transmission

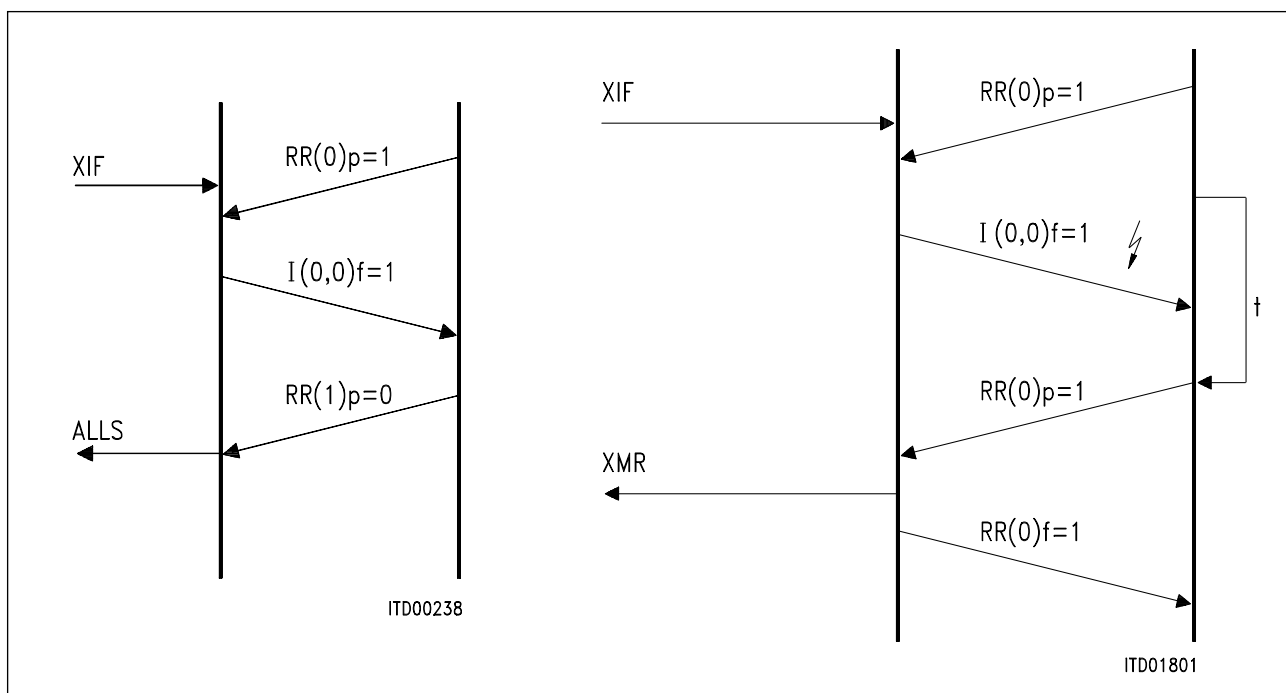

Figure 29a
Data Transmission (no error)

Figure 29b
Data Transmission (error)

5.2.3 Error Handling

Depending on the error type, erroneous frames are handled according to **table 3**.

**Table 3
Error Handling**

Frame Type	Error Type	Generated Response	Generated Interrupt	Rec. Status
I	CRC error	–	RME	CRC error
	aborted	–	RME	abort
	unexpec. N(S)	S-frame	–	–
	unexpec. N(R)	–	PCE	–
S	CRC error	–	–	–
	aborted	–	–	–
	unexpec. N(R)	–	PCE	–
	with I-field	–	PCE	–

Note: The station variables (V(S), V(R)) are not changed.

5.3 SDLC Loop

As a special variant of IBM's SDLC protocol the SDLC loop is used to connect several secondary (= slave) stations to one primary (= master) station. Different from standard HDLC, a reserved bit sequence is defined as 'End of Poll' sequence (EOP = one '0' bit, followed by at least 7 '1' bits). Note that in standard HDLC this sequence is defined as Abort Sequence, therefore with SDLC loop frame abortion is not available.

The ESCC2 facilitates entering and leaving the loop. In contrast to the protocol support described above, autonomous processing of S- and I-frames is not implemented by the circuit but is left to software. Prerequisite for correct operation is

- SDLC Loop mode enabled (register CCR0)
- Normal Response Mode selected (XBCH:NRM = '1')
- non-auto-mode or transparent mode with 8-bit address field selected
- external timer mode
- NRZ or NRZI data encoding enabled (register CCR0); no bus configuration
- RxCLK = TxCLK
- Interframe Timefill = Flags

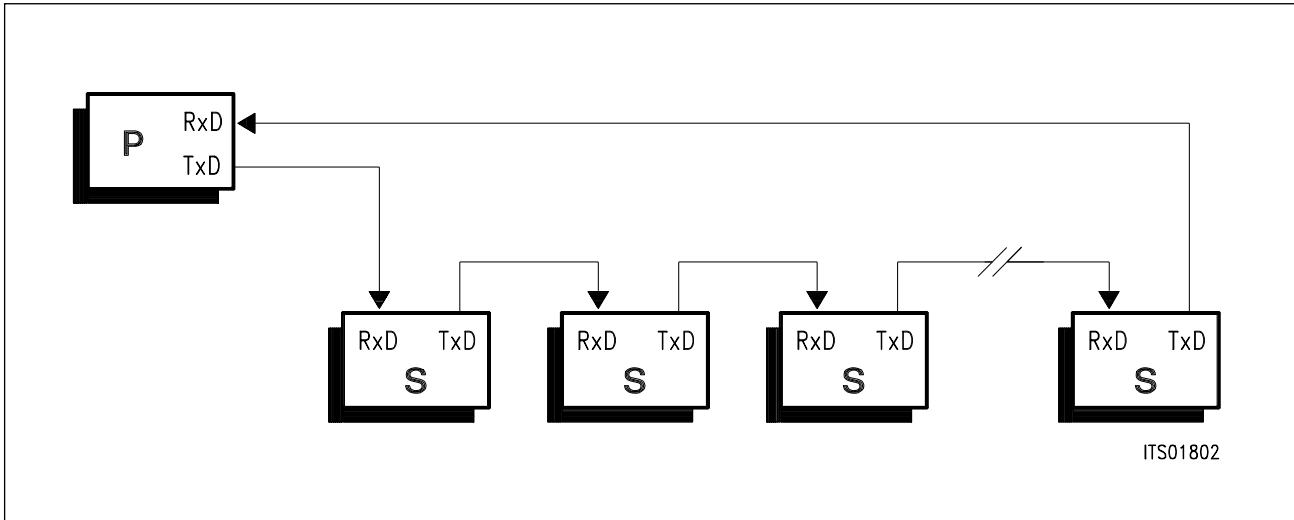

Figure 30
SDLC Loop

The loop is formed by connecting TxD output of one station to the RxD input of the next one (refer to **figure 30**). This configuration is physically a loop, but logically a point-to-multipoint configuration.

In every Secondary Station data flow from RxD to TxD is handled depending on Secondary's current state as follows:

- Initially, RxD and TxD are connected together with gate delay (**OFF Loop state**). Data sent out from the Primary is passed on by every Secondary to the next one. Thus, data is transparent to all Secondaries.
- After reception of an EOP sequence a Secondary can go to the **ON Loop** state. As opposed to the Off Loop state, all data is forwarded to the next station with one bit delay.
- If a Secondary is requested (polled) by the Primary to transmit data or responses, it has to wait for reception of a further EOP sequence. By flipping the seventh '1' of the EOP sequence to '0' it generates a flag sequence and consequently all following Secondary Stations are inhibited from sending. Simultaneously, RxD is disconnected from TxD and transmission of a frame (or several frames) may start (**Active ON Loop state**). After terminating transmission the station reconnects RxD to TxD. Thus, an EOP sequence is formed and another station may start data transmission.

Processing the EOP sequences is handled automatically by the ESCC2: commands (GLP, GALP in register CCR1) and state indications (interrupts EOP, OLP, AOLP in register ISR1) are provided to control and monitor the state of the ESCC2 as Secondary Station.

Figure 31 shows the state diagram for the Secondary. Note that in order to be able to hold 'Active On Loop' state 'flags' has to be selected as interframe time fill, as opposed to 'idle'.

Note: The Primary Station has to operate in standard SDLC mode.

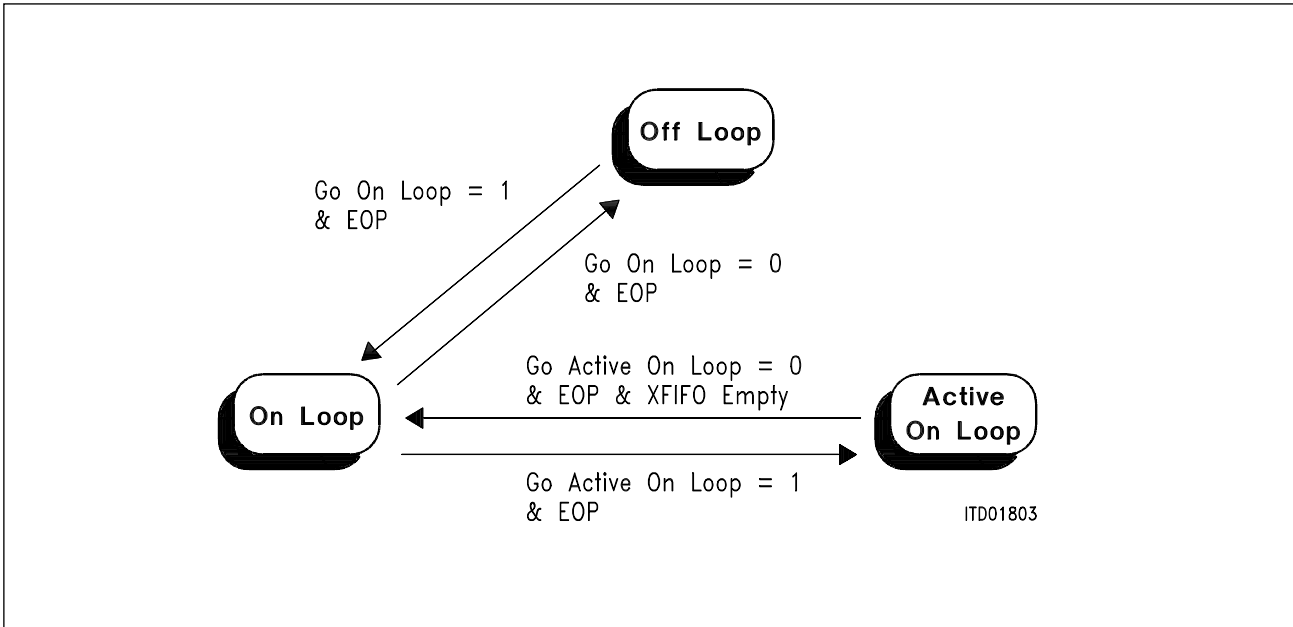

Figure 31
State Diagram of SDLC Loop/Secondary

Reception of Frames

SDLC Loop as special variant of the SDLC protocol works in half-duplex normal response mode, that means that data transmission and data reception at the same time is not permitted. Normally, data reception is only possible in the On Loop state.

The ESCC2, however, allows data reception in every state. Activation/deactivation of the receiver is effected by the user by programming the RAC bit in register MODE.

Transmission of Frames

Sending frames is only possible in the Active On Loop state. Here, transmission can start with the XTF command. If necessary, flags as Interframe Timefill are inserted before the current frame begins (the modified EOP and the first flag may share a '0'). After finishing frame transmission, flags as Interframe Timefill are again sent until the 'Go Active On Loop' command (GALP) is reset. By returning to On Loop state an EOP sequence is formed, the transmitter is disabled and RxD is connected to TxD again with one bit delay.

Note: XTF or XIF may be issued before the Active On Loop state is reached. In this case, transmission starts immediately after entering the Active On Loop state. The opening flag of the first frame is sent out immediately following after the modified EOP sequence (both may share a '0').

5.4 Special Functions

5.4.1 Shared Flags

The closing flag of a previously transmitted frame simultaneously becomes the opening flag of the following frame if there is one to be transmitted. The 'Shared Flag' feature is enabled by setting bit SFLG in control register CCR1.

5.4.2 Preamble Transmission

If enabled via register CCR3, a programmable 8-bit pattern (register PRE) is transmitted with a selectable number of repetitions after Interframe Timefill transmission is stopped and a new frame is ready to be sent out.

Note: Zero Bit Insertion is disabled during preamble transmission. To guarantee correct function the programmed preamble value should be different from Receive Address Byte values defined for any of the connected stations.

5.4.3 CRC-32

In HDLC/SDLC mode, error protection is done by CRC generation and checking.

In standard applications, CRC-CCITT algorithm is used. The Frame Check Sequence at the end of each frame consists of two bytes of CRC checksum.

If required, the CRC-CCITT algorithm can be replaced by the CRC-32 algorithm, enabled via register CCR2. In this case the Frame Check Sequence consists of four bytes.

5.4.4 Extended Transparent Transmission and Reception

When programmed in the extended transparent mode via the MODE register (MODE:MDS1, MDS0 = '11'), each channel of the ESCC2 performs fully transparent data transmission and reception without HDLC framing, i.e. without

- FLAG insertion and deletion
- CRC generation and checking
- bit stuffing.

In order to enable fully transparent data transfer, RAC bit in MODE has to be reset and FF_H has to be written to XAD1, XAD2 and RAH2.

Data transmission is always performed out of XFIFO by directly shifting the contents of XFIFO via the serial transmit data pin (TxD). Transmission is initiated by setting CMDR:XTF (08_H); end of transmission is indicated by ISR1:EXE (10_H).

In receive direction, the character last assembled via receive data line (RxD) is available in RAL1 register. Additionally, in extended transparent mode 1 (MODE: MDS1, MDS0, ADM = '111'), received data is shifted into RFIFO.

This feature can be profitably used e.g. for:

- user specific protocol variations
- line state monitoring, or
- test purposes, in particular for monitoring or intentionally generating HDLC protocol rule violations (e.g. wrong CRC)

Character or octet boundary synchronization can be achieved by using clock mode 1 with an external receive strobe input to pin CD.

5.4.5 Cyclic Transmission (fully transparent)

If the extended transparent mode is selected, the ESCC2 supports the continuous transmission of the contents of the transmit FIFO.

After having written 1 to 32 bytes to XFIFO, the command XREP.XTF.XME via the CMDR register (bit 7 ... 0 = '00101010' = 2A_H) forces the ESCC2 to repeatedly transmit the data stored in XFIFO via TxD pin.

The cyclic transmission continues until a reset command (CMDR: XRES) is issued, after which continuous '1's are transmitted.

Note: In DMA mode the command XREP and XTF has to be written to CMDR.

5.4.6 Continuous Transmission (DMA mode only)

If data transfer from system memory to the ESCC2 is done by DMA (DMA bit in XBCH set), the number of bytes to be transmitted is usually defined via the Transmit Byte Count registers (XBCH, XBCL: bits XBC11 ... XBC0).

Setting the 'Transmit Continuously' (XC) bit in XBCH, however, the byte count value is ignored and the DMA interface of ESCC2 will continuously request for transmit data any time 32 new bytes can be entered in XFIFO.

This feature can be used e.g. to transmit frames of length higher than the byte count specified by XBCH, XBCL (frames with more than 4096 bytes).

Note: If the XC bit is reset during continuous transmission, the transmit byte count becomes valid again, and the ESCC2 will request the amount of DMA transfers programmed via XBC11 ... XBC0. Otherwise, the continuous transmission and the generation of DMA requests is stopped when a data underrun condition occurs in XFIFO. Instead of CRC, continuous '1's (IDLE) are transmitted thereafter.

5.4.7 Receive Length Check Feature

The ESCC2 offers the possibility to supervise the maximum length of received frames and to terminate data reception in case this length is exceeded.

This feature is controlled via the special Receive Length Check Register (RLCR).

The function is enabled by setting the RC (Receive Check) bit in RLCR and programming the maximum frame length via bits RL6 ... RL0. The maximum receive length can be determined as a multiple of 32-byte blocks as follows:

$$\text{MAX_LENGTH} = (\text{RL} + 1) \times 32$$

where RL is the value written to RL6 ... RL0.

All frames exceeding this length are treated as if they had been aborted by the remote station, i.e. the CPU is informed via an

- RME interrupt, and the
- RAB bit in RSTA register is set.

To distinguish this from the case where an abort sequence is indeed received (sent by the remote station), the receive byte count registers RBCH, RBCL will contain a value exceeding the maximum receive length (via RL6 ... RL0) by one or two bytes.

5.4.8 One Bit Insertion

Similar to the zero bit insertion (bit stuffing) mechanism, as defined by the HDLC protocol, the ESCC2 offers a completely new feature of inserting/deleting a one after seven consecutive 'zeros' in the transmit/receive data stream, if the serial channel is operating in a bus configuration. This method is useful if clock recovery is to be performed by DPLL.

Since only NRZ data encoding is supported in a bus configuration, there are possibly long sequences without edges in the receive data stream in case of successive '0's received, and the DPLL may lose synchronization.

Using the one bit insertion feature by setting the OIN bit in the CCR1 register, however, it is guaranteed that at least after

- 5 consecutive '1's a '0' will appear (bit stuffing), and after
- 7 consecutive '0's a '1' will appear (one insertion)

and thus a correct function of the DPLL is ensured.

Note: As with the bit stuffing, the 'one insertion' is fully transparent to the user, but it is not in accordance with the HDLC protocol, i.e. it can only be applied in proprietary systems using circuits that also implement this function, such as the SAB 82525/SAB 82526.

5.4.9 CRC ON/OFF Feature (version 2 upward)

As an option in non-auto mode or transparent mode 0, the internal handling of received and transmitted CRC checksum can be influenced via control bits CCR3:RCRC and CCR3:XCRC.

Receive direction:

The received CRC checksum is always assumed to be in the 2 (CRC-CCITT) or 4 (CRC-32) last bytes of a frame, immediately preceding a closing flag. In the version 1 of ESCC2 a check is performed on the CRC but the received CRC bytes are not transferred to the RFIFO. In version 2 upwards, if CCR3:RCRC is set, the received CRC checksum will be written to RFIFO where it precedes the frame status byte (contents of register RSTA). The received CRC checksum is additionally checked for correctness. If non-auto mode is selected, the limits for 'Valid Frame' check are modified (refer to description of bit RSTA:VFR).

Transmit direction:

If CCR3:XCRC is set, the CRC checksum is not generated internally. The checksum has to be provided via the transmit FIFO (XFIFO) as the last two or four bytes. The transmitted frame will only be closed automatically with a (closing) flag.

Note: The ESCC2 does not check whether the length of the frame, i.e. the number of bytes, to be transmitted makes sense or not.

5.4.10 Receive Address Handling (version 2 upward)

Mask for Address Detection

The Receive Address Low/High Byte (RAL1/RAH1) can be masked by setting the corresponding bits in the mask registers (AML/AMH) to allow extended broadcast address recognition. This feature is applicable to all operating modes with address recognition (auto mode, non-auto mode and transparent mode 1). It is disabled if all bits of registers AML and AMH are set to 'zero' (RESET value). The function of RAL2/RAH2 and detection of the fixed group address FE_H or FC_H if applicable to the selected operating mode remain unchanged.

Note: As a very useful option, the detected receive address can be pushed to RFIFO (CCR3:RADD).

Receive Address Pushed to RFIFO

As an option in the auto mode, non-auto mode and transparent mode 1, the address field of received frames can be pushed to RFIFO (first one/two bytes of the frame). This function is especially useful in conjunction with the extended broadcast address recognition. It is enabled by setting control bit CCR3:RADD.

Note: In this case the ratio of receive frequency (f_r) to transmit frequency (f_x) and to master clock frequency (f_m) must fulfill:

$$f_r/f_x < 1.5 \text{ (normal operation),}$$

$$f_r/f_m < 1.5 \text{ (master clock operation).}$$

Asynchronous Serial Mode

6 Asynchronous Serial Mode

6.1 Character Frame

Character framing is achieved by special start and stop bits. Each data character is preceded by one Start bit and terminated by one or two stop bits. The character length is selectable from 5 up to 8 bits. Optionally, a parity bit can be added which complements the number of ones to an even or odd quantity (even/odd parity). The parity bit can also be programmed to have a fixed value (Mark or Space). **Figure 32** shows the asynchronous character format.

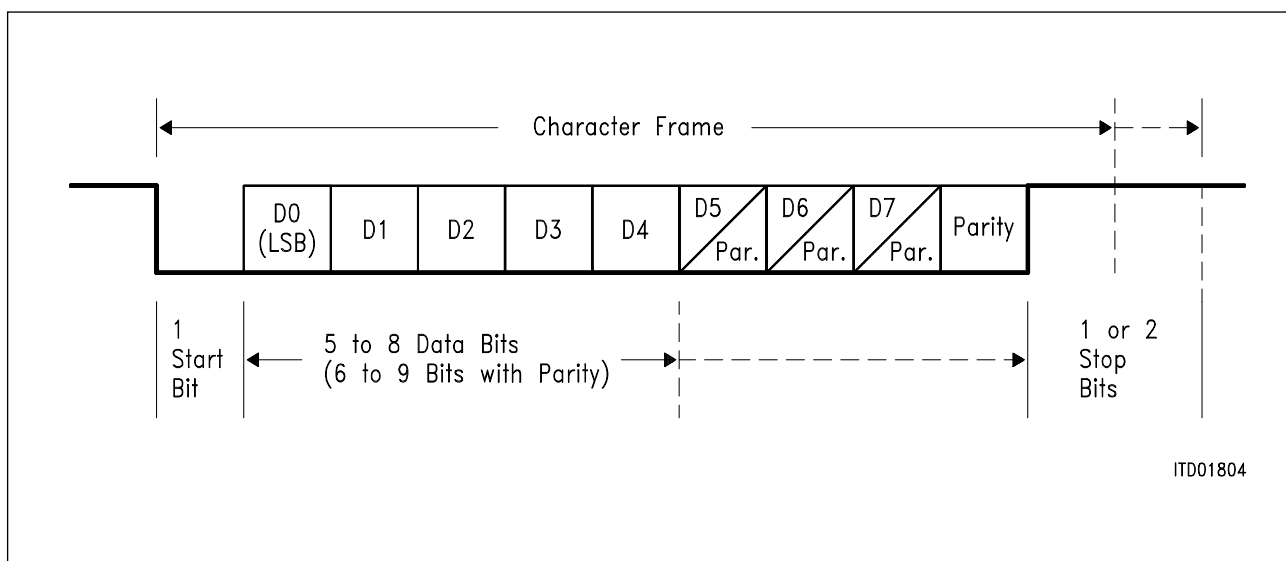

Figure 32
Asynchronous Character Frame

Asynchronous Serial Mode**6.2 Data Reception****6.2.1 Operating Modes**

The ESCC2 offers the flexibility to combine clock modes, data encoding and data sampling in many different ways. However, only definite combinations make sense and are recommended for correct operation:

Asynchronous Mode

Prerequisites:

- Bit clock rate 16 selected (CCR1:BCR = '1')
- Clock mode 0, 1, 3b, 4, or 7b selected
- NRZ data encoding

The receiver which operates with a clock rate equal to 16 times the nominal data bit rate, synchronizes itself to each character by detecting and verifying the start bit. Since character length, parity and stop bit length is known, the ensuing valid bits are sampled. Oversampling (3 samples) around the nominal bit center in conjunction with majority decision is provided for every received bit (including start bit).

The synchronization lasts for one character, the next incoming character causes a new synchronization to be performed. As a result, the demand for high clock accuracy is reduced. Two communication stations using the asynchronous procedure are clocked independently, their clocks need not be in phase or locked to exactly the same frequency but, in fact, may differ from one another within a certain range.

Isochronous Mode

Prerequisites:

- Bit clock rate 1 selected (CCR1:BCR = '0')
- Clock mode 2, 3a, 6, or 7a (DPLL mode) has to be used in conjunction with FM0, FM1 or Manchester encoding.

The isochronous mode uses the asynchronous character format. However, each data bit is only sampled once (no oversampling).

In clock modes 0 and 1, the input clock has to be externally phase locked to the data stream. This mode allows much higher transfer rates. Clock modes 3b, 4 and 7b are not recommended due to difficulties with bit synchronization when using the internal baud rate generator.

In clock modes 2, 3a, 6, and 7a, clock recovery is provided by the internal DPLL. Correct synchronization of the DPLL is achieved if there are enough edges within the data stream, which is generally ensured only if Bi-Phase encoding (FM0, FM1 or Manchester) is used.

Asynchronous Serial Mode**6.2.2 Storage of Data**

If the receiver is enabled, received data is stored in RFIFO (the LSB is received first). Moreover, the CD input may be used to control data reception. Character length, number of stop bits and the optional parity bit are checked. Storage of parity bits can be disabled. Errors are indicated via interrupts. Additionally, the character error status (framing and parity) can optionally be stored in the RFIFO (refer to **chapter 10.1.2**).

Filling of the accessible part of RFIFO is controlled by

- a programmable threshold level
- detection of the programmable Termination Character (optional).

Additionally, the time-out condition as optional status information indicates that a certain time (refer to register ISR0) has elapsed since the reception of the last character.

6.3 Data Transmission

The selection of asynchronous or isochronous operation has no further influence on the transmitter. The bit clock rate is solely a dividing factor for the selected clock source.

Transmission of the contents of XFIFO starts after the XF command is issued (the LSB is sent out first). Further data is requested by interrupt (XPR) or DMA. The character frame for each character, consisting of start bit, the character itself with defined character length, optionally generated parity bit and stop bit(s) is assembled.

After finishing transmission (indicated by the 'All Sent' interrupt), IDLE (logical '1') is transmitted on TxD.

Additionally, the $\overline{\text{CTS}}$ signal may be used to control data transmission.

6.4 Special Features**6.4.1 Break Detection/Generation**

Break generation: On issuing the XBRK command (register DAFO), the TxD pin is immediately forced to physical '0' level with the first following clock edge, and released with the first clock edge after this command has been reset.

Break detection: The ESCC2 recognizes the break condition upon receiving consecutive (physical) '0's for the defined character length, the optional parity and the selected number of stop bits ('zero' character and framing error). The 'zero' character is not pushed to RFIFO. If enabled, the BRK interrupt is generated.

The break condition will be present until a '1' is received which is indicated by the 'Break Terminated' interrupt (BRKT).

6.4.2 Flow Control by XON/XOFF (version 2 upward)

Programmable XON and XOFF

Two eight-bit control registers (XON, XOFF) contain the programmable values for XON and XOFF characters. The number of significant bits in a register is determined by the programmed character length (right justified).

Two programmable eight-bit registers MXN and MXF serve as mask registers for the characters in XON and XOFF, respectively:

A '1' in a mask register has the effect that no comparison is performed between the corresponding bits in the received characters ('don't cares') and the XON and the XOFF register. At RESET, the mask registers are 'zero'ed, i.e. all bit positions are compared.

A received character is considered to be recognized as a valid XON or XOFF character

- if it is correctly framed (correct length),
- if its bits match the ones in the XON or XOFF registers over the programmed character length,
- if it has correct parity (if applicable).

Received XON and XOFF characters are always stored in the receive FIFO, as any other characters.

In-Band Flow Control of Transmitted Characters

Recognition of an XON or an XOFF character causes always a corresponding maskable interrupt status to be generated (ISR1:XON / IMR1:XON; ISR1:XOFF / IMR1:XOFF).

Further action depends on the setting of a control bit MODE:FLON (Flow Control On):

0: No further action is automatically taken by the ESCC2.

1: The reception of an XOFF character automatically turns off the transmitter after the currently transmitted character (if any) has been completely shifted out (XOFF state).

The reception of an XON character automatically makes the transmitter resume transmitting (XON state).

After hardware RESET, bit MODE:FLON is at '0'.

When bit MODE:FLON is made to go from '0' to '1', the transmitter is first in the 'XON state', until an XOFF character is received.

When bit MODE:FLON is made to go from '1' to '0', the transmitter always goes in the 'XON state', and transmission is only controlled by the user and by the CTS input.

The in-band flow control of the transmitter via received XON and XOFF characters can be combined with control via CTS pin, i.e. the effect of the CTS pin is independent of whether in-band control is used or not. The transmitter is enabled only if CTS is 'low' and XON state has been reached.

Asynchronous Serial Mode

Transmitter Status Bit

The status bit 'Flow Control Status' (STAR:FCS) indicates the current state of the transmitter, as follows:

0: if the transmitter is in XON state,

1: if the transmitter is in XOFF state.

Note: The transmitter cannot be turned off by software without disrupting data possibly remaining in the XFIFO.

Flow Control for Received Data

After writing a character value to register TIC (Transmit Immediate Character) its contents are inserted in the outgoing character stream

- immediately upon writing this register by the microprocessor if the transmitter is in IDLE state. If no further characters (XFIFO contents) are to be transmitted, i.e. the transmitter returns to IDLE state after transmission of TIC, an ALLS (All Sent) interrupt will be generated.
- after the end of a character currently being transmitted if the transmitter is not in IDLE state. This does not affect the contents of the XFIFO. Transmission of characters from XFIFO is resumed after the contents of register TIC are shifted out.

Transmission via this register is possible even when the transmitter is in XOFF state (however, $\overline{\text{CTS}}$ must be 'low').

The TIC register is an eight-bit register. The number of significant bits is determined by the programmed character length (right justified). Parity value (if programmed) and selected number of stop bits are automatically appended, similar to the characters written in the XFIFO. The usage of TIC is independent of flow control, i.e. is not affected by bit MODE:FLON.

To control access to register TIC, an additional status bit STAR:TEC (TIC Executing) is implemented which signals that transmission command of currently programmed TIC is accepted but not completely executed. Further access to register TIC is only allowed if bit STAR:TEC is '0'.

6.4.3 Selectable Out-of-band Flow Control for Transmitter and Receiver (V3.x)

Transmitter

The transmitter output is enabled if $\overline{\text{CTS}}$ signal is 'LOW' OR the recognition of the XON characters (if MODE:FLON = '1'). If the MODE:FLON = '0', then the transmitter is only enabled when the $\overline{\text{CTS}}$ signal is 'LOW'. Setting the **MODE:FCTS = '1'** allows the transmitter to send data independent of the condition of the $\overline{\text{CTS}}$ signal, the in-band flow control (XON/XOFF) method would still be operational if MODE:FLON = '1'.

Asynchronous Serial Mode

Receiver

For some applications it is desirable to provide means of out-of-band flow control to indicate to the far end transmitter that the local receiver's buffer is getting full.

This flow control can be used between two DTEs as shown in **figure 33** and between a DTE and a DCE (MODEM) as shown in **figure 34** that supports this kind of bi-directional flow control.

Setting **MODE:FRTS = '1'** and **MODE:RTS = '0'** invokes this out-of-band flow control for the receiver. When the shadow part of RFIFO has reached a set threshold of 28 bytes, the $\overline{\text{RTS}}$ signal is forced inactive (HIGH). When the shadow part of the RFIFO is empty, the $\overline{\text{RTS}}$ is re-asserted ('LOW'). Note that the data is immediately transferred from the shadow RFIFO to the user accessible RFIFO (as long as there is space available). So when the shadow RFIFO reaches 28 bytes threshold, there is 4 more byte storage available before overflow can occur. This allows sufficient time for the far end transmitter to react to the change in the $\overline{\text{RTS}}$ signal and stop sending more data.

Figure 33 shows the connection between two ESCC2 Version 3.2 devices as DTEs. The $\overline{\text{RTS}}_A$ of DTE_A (ESCC2) feeds the $\overline{\text{CTS}}_B$ input of the second DTE_B (another ESCC2). For example while DTE_A is receiving data and its receiver RFIFO threshold is reached, the $\overline{\text{RTS}}_A$ signal goes in-active HIGH forcing the $\overline{\text{CTS}}_B$ to become in-active indicating to DTE_B to stop transmitting. Both DTE devices should also be using the $\overline{\text{CTS}}$ signal to flow control their transmitters. When the shadow RFIFO in DTE_A is cleared the $\overline{\text{RTS}}_A$ goes active 'LOW' and this signals the far end to resume transmission. Data flow control from DTE_B to DTE_A works in a similar way.

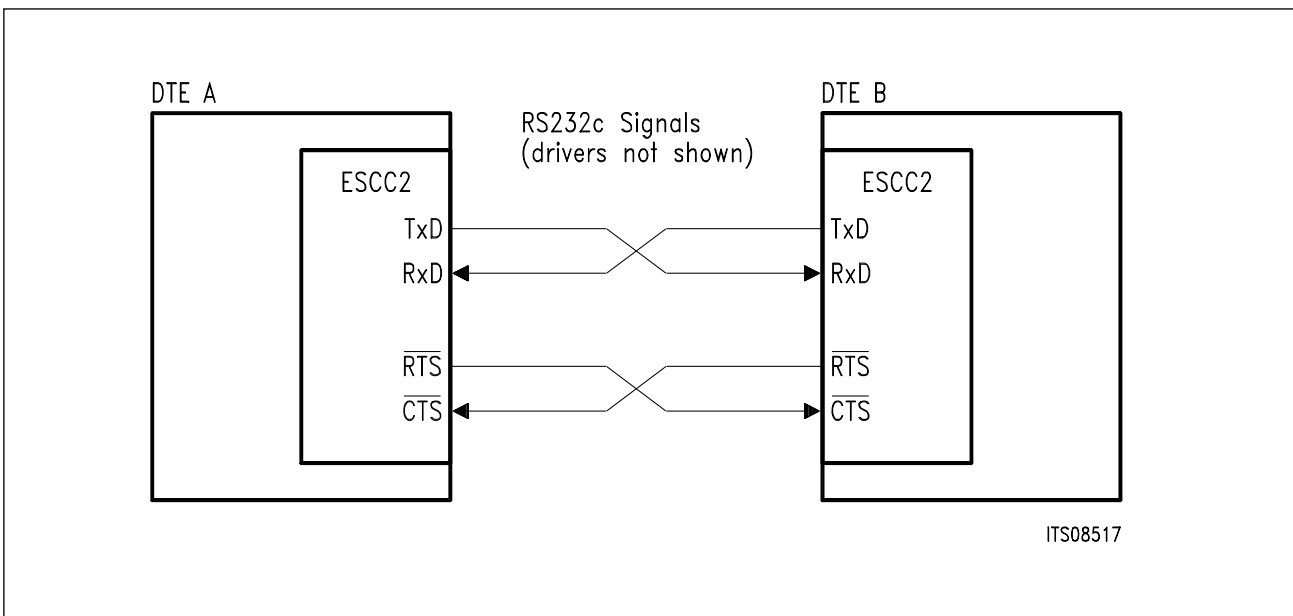

Figure 33
Out-of-Band DTE-DTE Bi-directional Flow Control

Asynchronous Serial Mode

Figure 34 shows an ESCC2 as a DTE connected to a DCE (MODEM equipment).

The \overline{RTS}_A feeds the \overline{RTS}_B input of the DCE (MODEM equipment) that supports bi-directional flow control. So when the DTE_A's receiver threshold is reached, the \overline{RTS}_A signal goes active HIGH which is sensed by the DCE and it stops transmitting. Similarly if the DCE's receiver threshold is reached, it deactivates the \overline{CTS}_B (HIGH) and causes the DTE to stop transmitting. These type of DCEs have fairly deep buffers to ensure that it can continue to receive data from the line even though it is unable to pass the data to the DTE for short periods of time. Note that a ESCC2 (Version 3.2) can also be used in the DCE equipment as shown. Exchange of signals (e.g. \overline{RTS} to \overline{CTS}) is necessary inside the DCE equipment.

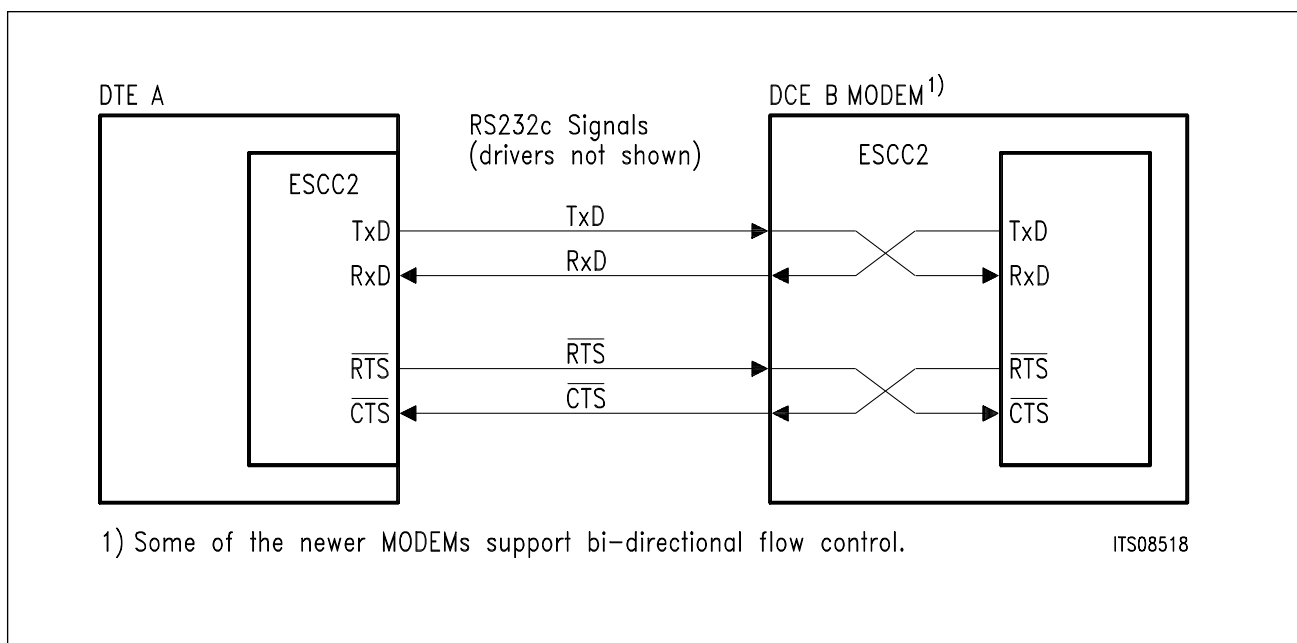

Figure 34
Out-of-Band DTE-DCE Bi-directional Flow Control

\overline{RTS} and \overline{CTS} are used to indicate when the local receiver's buffer is nearly full. This alerts the far end transmitter to stop transmitting.

The combination of transmitter and receiver out-of-band control features mentioned above enables data to be exchanged between two devices without software intervention for flow control.

6.4.4 In-band Flow Control Transparency

In ASYNC modes an optional in-band flow control is provided with the XON/XOFF characters.

If MODE:FLON bit = '1' then the transmitter output is controlled based on recognition of the XON/XOFF characters at the receiver.

A new optional function 'Disable XON/XOFF Storage' bit (DXS) in the RFC register is used to determine if the received in-band flow control characters (XON/XOFF) are to be stored in the RFIFO or to be removed from the incoming data stream. **Setting the control bit RFC:DXS = '1' (in conjunction with MODE:FLON = '1') causes the XON/XOFF received characters to be discarded.** Normally with RFC/DXS = '0' (and on RESET condition) the received XON/XOFF characters are stored in the RFIFO along with the data.

6.4.5 Continuous Transmission (DMA mode only)

If data transfer from system memory to the ESCC2 is done by DMA (DMA bit in XBCH set), the number of characters to be transmitted is usually defined via the Transmit Byte Count registers (XBCH, XBCL: bits XBC11 ... XBC0).

However, if the 'Transmit Continuously' (XC) bit in XBCH is set, the byte count value is ignored and the DMA interface of ESCC2 will continuously request for transmit data any time 32 new characters can be stored in XFIFO.

Note: If the XC bit is reset during continuous transmission, the transmit byte count becomes valid again, and the ESCC2 will request the amount of DMA transfers programmed via XBC11 ... XBC0. Otherwise, the continuous transmission is stopped when a data underrun condition occurs in XFIFO, i.e. the DMA controller does not transfer further data to ESCC2. In this case continuous '1's (IDLE) are transmitted.

Character Oriented Serial Mode (MONOSYNC/BISYNC)

7 Character Oriented Serial Mode (MONOSYNC/BISYNC)

7.1 Data Frame

Character oriented protocols achieve synchronization between transmitting and receiving station by means of special SYN characters. Two examples are the MONOSYNC and IBM’s BISYNC procedures. BISYNC has two starting SYN characters while MONOSYNC uses only one SYN. **Figure 35** gives an example of the message format.

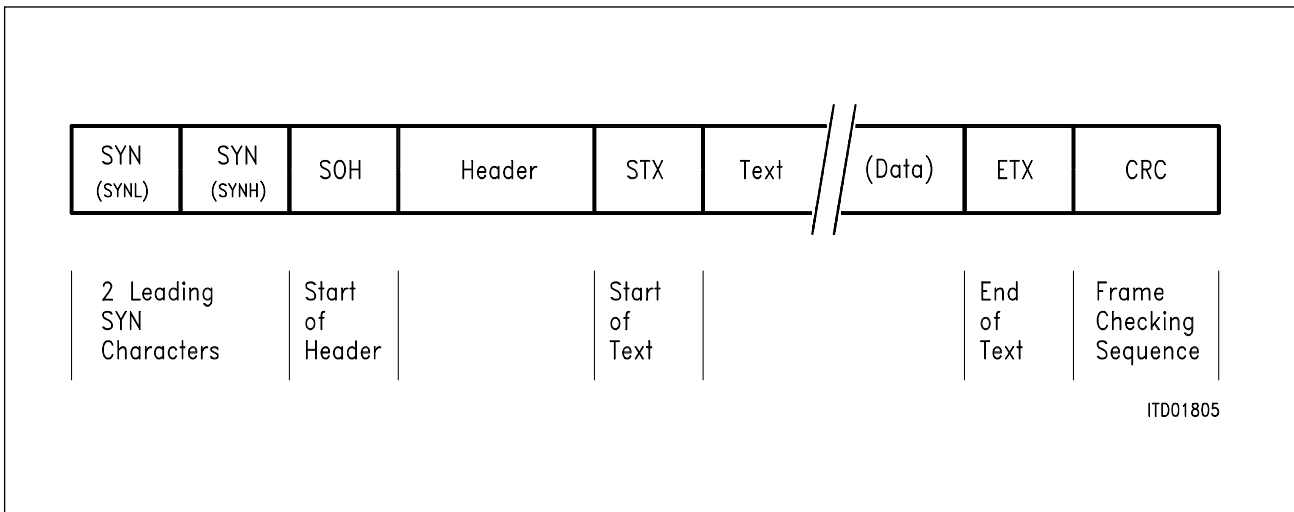

Figure 35
BISYNC Message Format

The SYN character, its length, the length of data characters and additional parity are programmable:

- 1 SYN with 6 or 8 bit length (MONOSYNC), programmable via Register SYNL.
- 2 SYN with 6 or 8 bit length each (BISYNC), programmable via registers SYNL and SYNH.
- Data character length may vary from 5 to 8 bits.
- Parity information (even/odd parity, Mark, Space) may be appended to the character.

Character Oriented Serial Mode (MONOSYNC/BISYNC)**7.2 Data Reception**

The receiver is generally activated by setting the RAC bit in the MODE register. Additionally, the CD signal may be used to control data reception. After issuing the HUNT command, the receiver monitors the incoming data stream for the presence of specified SYN character(s). However, data reception is still disabled. If synchronization is gained by detecting the SYN character(s), SCD interrupt is generated and **all** data is pushed to RFIFO, i.e. control sequences, data characters and optional CRC frame checking sequence (the LSB is received first). In normal operation, SYN characters are excluded from storage to RFIFO. SYN character length can be specified independently of the selected data character length. If required, the character parity bit and/or parity status is FIFOed together with each data byte.

As an option, the loading of SYN characters in RFIFO may be enabled by setting the SLOAD bit in register RFC. Note that in this case SYN characters are treated as data. Consequently, for correct operation it must be guaranteed that SYN character length equals the character length + optional parity bit. This is the user's responsibility.

Filling of the accessible part of RFIFO is controlled by a programmable threshold level. RFIFO read is requested by interrupt (RPF) or DMA.

Reception is stopped if

1. the receiver is deactivated by resetting the RAC bit, or
2. the CD signal goes inactive (if Carrier Detect Auto Start is enabled), or
3. the HUNT command is issued again, or
4. the Receiver Reset command (RRES) is issued, or
5. a programmed Termination Character has been found (optional).

On actions 1. and 2., reception remains disabled until the receiver is activated again. After this is done, and generally in cases 3. and 4., the receiver returns to the (non-synchronized) Hunt state. In case 5. a HUNT command has to be issued. Reception of data is internally disabled until synchronization is regained.

Note: Further checking of frame length, extraction of text or data information and verifying the Frame Checking Sequence (e.g. CRC) has to be done by the microprocessor.

Character Oriented Serial Mode (MONOSYNC/BISYNC)**7.3 Data Transmission**

Transmission of data written to XFIFO is initiated after the Transmit Frame command (XF) is issued (the LSB is sent out first). Additionally, the $\overline{\text{CTS}}$ signal may be used to control data transmission. Further data is requested by interrupt (XPR) or DMA. The message frame is assembled by appending all data characters to the specified SYN character(s) until Transmit Message End is detected (XME command in interrupt mode, or, in DMA mode, when the number of characters specified in XBCH, XBCL have been transferred). Internally generated parity information may be added to each character (SYN, CRC and Preamble characters are excluded).

If enabled via CRC Append bit (CAPP), the internally calculated CRC checksum (16 bit) is added to the message frame. Selection between CRC-16 and CRC-CCITT algorithms is provided. For all characters which have to be included into CRC calculation, the CON flag has to be set to '1'. This flag which controls the CRC generator is FIFOed together with each character. There is no need to modify CON for every character loaded if continuous characters are to be either included into or excluded from CRC calculation.

Note: - Internally generated SYN characters are always excluded from CRC calculation,
- CRC checksum (2 bytes) is sent without parity.

The internal CRC generator is automatically initialized before transmission of a new frame starts. The initialization value is selectable.

After finishing data transmission, Interframe Timefill (SYN characters or IDLE) is automatically sent.

Character Oriented Serial Mode (MONOSYNC/BISYNC)**7.4 Special Functions****7.4.1 Preamble Transmission**

If enabled via register CCR3, a programmable 8-bit pattern (register PRE) is transmitted with a selectable number of repetitions after Interframe Timefill transmission is stopped and a new frame is ready to be sent out.

Note: If the preamble pattern equals the SYN pattern, reception is triggered by the preamble.

7.4.2 Continuous Transmission (DMA mode only)

If data transfer from system memory to the ESCC2 is done by DMA (DMA bit in XBCH set), the number of characters to be transmitted is usually defined via the Transmit Byte Count registers (XBCH, XBCL: bits XBC11 ... XBC0).

Setting the 'Transmit Continuously' (XC) bit in XBCH, however, the byte count value is ignored and the DMA interface of ESCC2 will continuously request for transmit data any time 32 new characters can be entered in XFIFO.

This feature can be used to transmit frames of length higher than the byte count specified by XBCH, XBCL (frames with more than 4095 bytes).

Note: If the XC bit is reset during continuous transmission, the transmit byte count becomes valid again, and the ESCC2 will request the amount of DMA transfers programmed via XBC11 ... XBC0. Otherwise, the continuous transmission and the generation of DMA input requests is stopped when a data underrun condition occurs in XFIFO. Instead of CRC, continuous '1's (IDLE) are transmitted thereafter.

7.4.3 CRC Parity Inhibit

If the internal CRC generator is not used for calculation of Frame Check Sequence, an externally calculated checksum (16 bits) can be appended to the message frame without internally generated parity information, although parity is enabled for data characters.

Prerequisites are:

- CRC generator disabled (CAPP = '0'),
- CON = '0' for all data characters which are to be included into parity generation (normal operation),
- CON = '1' for both bytes defining the CRC checksum,
- Message End indication has to be issued after the checksum is written to XFIFO.

The programmed character length has no influence on this function.

Serial Interface (layer-1 functions)

8 Serial Interface (layer-1 functions)

The two serial interfaces of the ESCC2 provide two fully independent communication channels, supporting layer-1 functions to a high degree by various means of clock generation and clock recovery.

Note: Since the two serial channels are completely independent, the functions described in this document apply to both channels A and B. For simplification purposes the indices A and B will usually be omitted from the signal names, and are implied.

8.1 Clock Modes

The ESCC2 includes an internal Oscillator (OSC) as well as independent Baud Rate Generator (BRG) and Digital Phase Locked Loop (DPLL) circuitry for each serial channel.

The transmit and receive clock can be generated either

- externally, and supplied via the RxCLK and/or TxCLK pins, or
- internally, by means of the
 - OSC and/or BRG, and
 - DPLL, recovering the receive (and optionally transmit) clock from the received data stream.

There are a total of 8 different clocking modes programmable via the CCR1 register, providing a wide variety of clock generation and clock pin functions, as shown in **table 4**:

**Table 4
Overview of Clock Modes**

Clock			
Type	Source	Generation	Mode
Receive Clock	RxCLK Pins	Externally	0, 1, 5
	DPLL	Internally	2, 3a, 6, 7a
	OSC		4
	BRG		3b, 7b
Transmit Clock	TxCLK Pins	Externally	0a, 2a, 6a
	RxCLK Pins	Internally	1,5
	DPLL		3a, 7a
	BRG ./.16		2b, 6b
	OSC		4
	BRG		0b, 3b, 7b

Serial Interface (layer-1 functions)

The transmit clock pins (TxCLK) may also output clock signals in certain clock modes if enabled via CCR2:TOE.

The clocking source for the DPLL's is always the internal BRG; the scaling factor (divider) of the BRG can be programmed through CCR2 and BGR registers between 1, 2, 4, 6 ... 2048.

The ESCC2's system clock is always derived from the transmit clock or from the master clock (if master clock mode is enabled).

Master Clock Capabilities

A new clock source can be defined as master clock to allow full functionality of the microprocessor interface (access to all status and control registers and FIFOs, DMA and interrupt support) independent from the receive and transmit clocks. This new function (enabled via bit CCR0:MCE) is useful for modem applications where continuous generation of the receive and especially of the transmit clock cannot be guaranteed. The master clock has to be supplied via pin XTAL1 (or a crystal connected to XTAL1 and 2). Depending on the version, the maximum clock rate is 10 MHz (SAB/SAF 82532 N-10 and SAB/SAF 82532 H-10) or 2 MHz (SAB 82532 N and SAB 82532 H).

*Note 1: The master clock is applicable to all clock modes except clock mode 5. For details refer to **table 5**.*

Note 2: If bus configuration is selected in HDLC/SDLC mode (CCR0:SC2 ... 0), the 'One'-Insertion (CCR1:OIN) cannot be used in conjunction with the master clock feature.

Note 3: In SDLC loop mode the master clock option is not available.

Note 4: The conditions for the ratio between transmit clock, master clock and receive clock frequencies must be fulfilled to guarantee correct function (refer to the notes of table 5).

Note 5: The internal timers run with the master clock.

Note 6: The serial interface (transmitter and receiver) are not sequenced by the master clock however the FIFOs, DMA-UNIT and TIMER are.

Clock Mode 0 (external clocks)

Separate, externally generated receive and transmit clocks are supplied to the ESCC2 via their respective pins. The transmit clock can be directly supplied by pin TxCLK (mode 0a) or generated by the internal baud rate generator from the clock supplied by pin XTAL1 (mode 0b). In the latter case, the transmit clock can be output via pin TxCLK.

Serial Interface (layer-1 functions)**Clock Mode 1 (receive/transmit strobes)**

Externally generated, but identical receive and transmit clocks are supplied via RxCLK. In addition, a receive strobe can be connected via CD and a transmit strobe via TxCLK. These strobe signals work on a per bit basis. The operating mode can be applied in time division multiplex applications or for adjusting disparate transmit and receive data rates.

Note: In Extended Transparent Mode (HDLC/SDLC), the above mentioned strobe signals provide byte synchronization (byte alignment).

Clock Mode 2 (receive clock from DPLL)

The BRG is driven by an external clock (RxCLK) and it delivers a reference clock of a frequency equal to 16 times the nominal bit rate for the DPLL which in turn generates the receive clock. Depending on the programming of the CCR2 register (bit SSEL), the transmit clock will be either an external clock signal (TxCLK) or the clock delivered by the BRG divided by 16. In the latter case, the transmit clock can be output via TxCLK.

Clock Mode 3 (receive and transmit clock from DPLL)

The BRG is fed with an externally generated clock via RxCLK. Depending on the value of bit CCR2:SSEL the BRG supplies either the reference clock of frequency equal to 16 times the nominal bit rate for the DPLL, which generates **both** the receive and transmit clock, or, the receive and transmit clock directly. This clock can be output via TxCLK.

Clock Mode 4 (OSC – direct)

The receive and transmit clocks are **directly** supplied by the OSC. In addition, this clock can be output via TxCLK.

Clock Mode 5 (time-slots)

This operation mode has been designed for application in time-slot oriented PCM systems.

Note: Clock mode 5 is only specified for versions SAB/SAF 82532 N-10 and SAB/SAF 82532 H-10, but not for versions SAB 82532 N and SAB 82532 H.

For correct operation only NRZ coding should be used.

The received and transmit clock are common for each channel and must be supplied externally via RxCLK pin. The ESCC2 receives and transmits only during certain time-slots

- of programmable width (1 ... 256 bit, via RCCR and XCCR registers), and
- of programmable location with respect to a frame synchronization signal (via CD pin).

One of up to 64 time-slots can be programmed independently for receive and transmit direction via TSAR and TSAX registers, and an additional clock shift of 0 ... 7 bits via TSAR, TSAX and CCR2 register. Together with bits XCS0 and RCS0 (LSB of clock

Serial Interface (layer-1 functions)

shift), located in the CCR2 register, there are 9 bits to determine the location of a time-slot.

Depending to the value programmed via those bits, the receive/transmit window (time-slot) starts with a delay of 1 (minimum delay) up to 512 clock periods following the frame synchronization signal and is active for the number of clock periods programmed via RCCR, XCCR (number of bits to be received/transmitted within a time-slot) as shown in **figure 36**.

If bit CCR2:TOE is set, the transmit time-slot is indicated by a control signal via TxCLK, which is set to 'low' during the transmit window.

Note: In HDLC/SDLC Extended Transparent modes above windows provide character synchronization (byte aligned). In extended transparent mode the width of the time-slots has to be $n \times 8$ bit. In all other modes they can be used to define windows down to a minimum length of one bit.

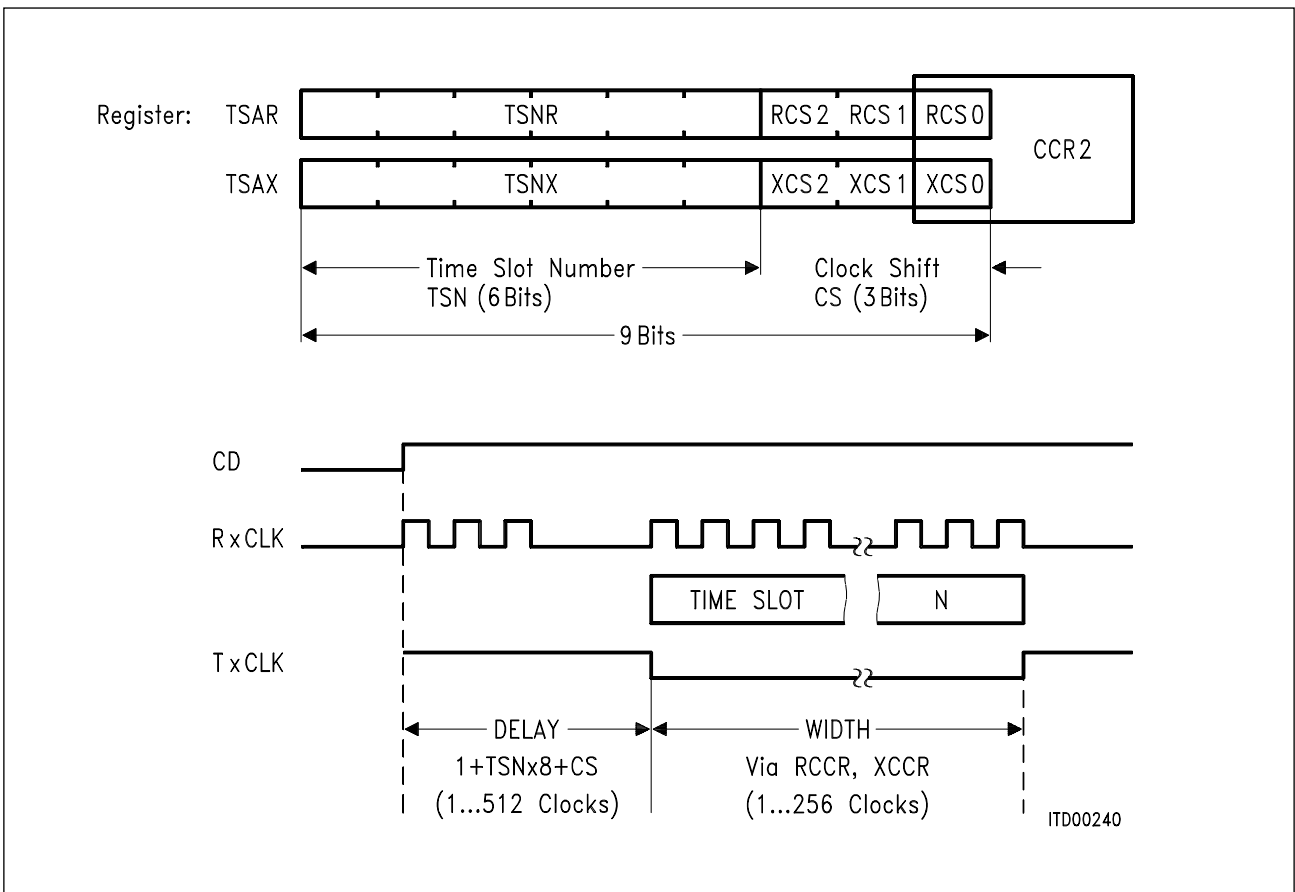

Figure 36
Location of Time-slots

Serial Interface (layer-1 functions)

Clock Mode 6 (OSC – receive clock from DPLL)

This clock mode is identical to clock mode 2 except that the clock for the BRG is delivered by the OSC and must not be supplied externally.

Clock Mode 7 (OSC – receive and transmit clock from DPLL)

Similar to clock mode 3, but BRG clock is provided by OSC.

Summary

The features of the different clock modes are summarized in **table 5**.

**Table 5
Clock Modes of ESCC2**

Channel Configuration		Clock Sources					Control Sources				
Clock Mode	CCR1: CM2, CM1,CM0	Master Clock CCR0: MCE = '1'	BRG	DPLL	REC	TRM	CD	R- Strobe	X- Strobe	Frame-Sync	Output via TxCLK (if CCR2: TOE = '1')
0a	0	OSC	–	–	RxCLK	TxCLK	CD	–	–	–	–
0b	1	OSC	OSC	–	RxCLK	BRG	CD	–	–	–	BRG
1	X	OSC	–	–	RxCLK	RxCLK	–	CD	TxCLK	–	–
2a	0	OSC	RxCLK	BRG	DPLL	TxCLK	CD	–	–	–	–
2b	1	OSC	RxCLK	BRG	DPLL	BRG/16	CD	–	–	–	BRG/16
3a	0	OSC	RxCLK	BRG	DPLL	DPLL	CD	–	–	–	DPLL
3b	1	OSC	RxCLK	–	BRG	BRG	CD	–	–	–	BRG
4	X	OSC	–	–	OSC	OSC	CD	–	–	–	OSC
5	X	–	–	–	RxCLK	RxCLK	–	(TSAR)	(TSAX)	CD	TS-Control
6a	0	OSC	OSC	BRG	DPLL	TxCLK	CD	–	–	–	–
6b	1	OSC	OSC	BRG	DPLL	BRG/16	CD	–	–	–	BRG/16
7a	0	OSC	OSC	BRG	DPLL	DPLL	CD	–	–	–	DPLL
7b	1	OSC	OSC	–	BRG	BRG	CD	–	–	–	BRG

Note 1: If ASYNC Mode is programmed, the baud rate depends on the Bit Clock Rate (1 or 16) selected by bit CCR1:BCR:

Clock Mode	Receive	Transmit
0a	RxCLK/BCR	TxCLK
0b	RxCLK/BCR	BRG
1	RxCLK/BCR	RxCLK/BCR
3b, 7b	BRG/BCR	BRG/BCR
4	OSC/BCR	OSC/BCR

When BCR is set to '16', oversampling (3 samples) in conjunction with majority decision is performed. BCR has no effect when using clock mode 2, 3a, 6, or 7a.

Serial Interface (layer-1 functions)

Note 2: Restrictions for frequency ratios between receive frequency (f_r), transmit frequency (f_x) and master clock frequency (f_m):

Normal mode; clock mode 0, 2a, and 6a: $f_r/f_x < 3^1)$

Master clock mode: $f_m/f_x \geq 2.5; f_r/f_m < 3^1)$.

There are no restrictions on the relative phases of the clocks. The conditions are valid independent of strobe signals or time-slot widths: i.e. in normal mode clock mode 1 always fulfills the condition, irrespective of how receive and transmit data are strobed. Thus, by using strobes the above condition may always be fulfilled irrespective of the net data rates.

Note 3: Restrictions for frequency ratios between receive frequency (f_r), transmit frequency (f_x) and master clock frequency (f_m):

Master clock mode: $f_r/f_m < 3^1)$

Non bus configuration: $f_m/f_x > 2.5$

In addition: For a given transmit clock f_x a master clock f_m with at least $1.25 f_m$ periods in the low phase of transmit clock f_x has to be provided.

Bus configuration: $f_m/f_x > 5$

In addition: For a given transmit clock f_x a master clock f_m with at least $2.5 f_m$ periods in the low phase of transmit clock f_x has to be provided.

Example 1: $f_x = 2$ MHz with low/high ratio of 0.25/0.75 $\Rightarrow f_m = 20$ MHz

(see **figure 37**)

Example 2: $f_x = 4$ MHz with low/high ratio of 0.75/0.25 $\Rightarrow f_m = 13.32$ MHz

(see **figure 38**)

Generally, in master clock mode the low/high ratio of transmit clock should be in the range 0.25/0.75 .. 0.75/0.25.

There are no restrictions on the relative phases of the clocks. The conditions are valid independent of strobe signals or time-slot widths: i.e. in normal mode clock mode 1 always fulfills the condition, irrespective of how receive and transmit data are strobed. Thus, by using strobes the above condition may always be fulfilled irrespective of the net data rates.

¹⁾ Reduced to 1.5 if receive address is pushed to RFIFO in HDLC/SDLC mode.

Serial Interface (layer-1 functions)

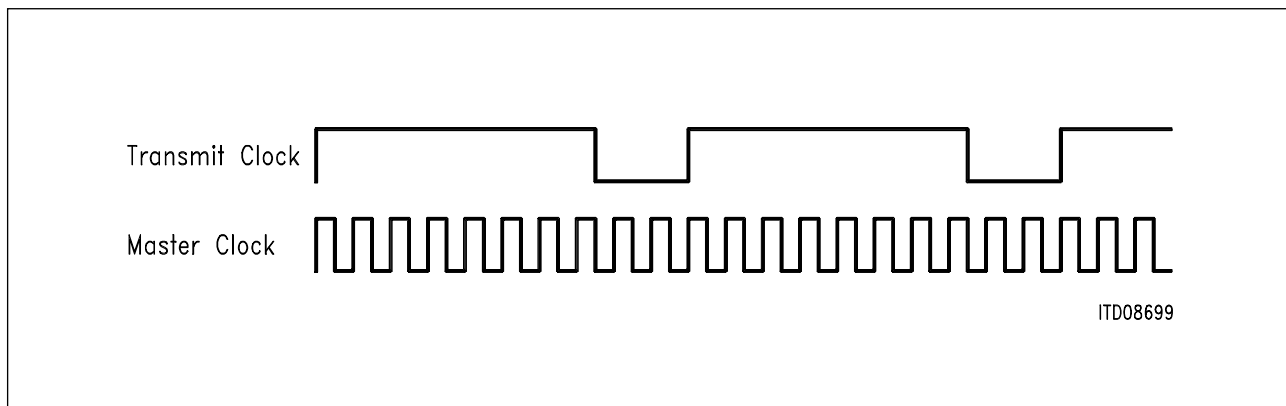

Figure 37
Short Low Phase of Transmit Clock for a Minimum of 2.5 Master Clock Cycles

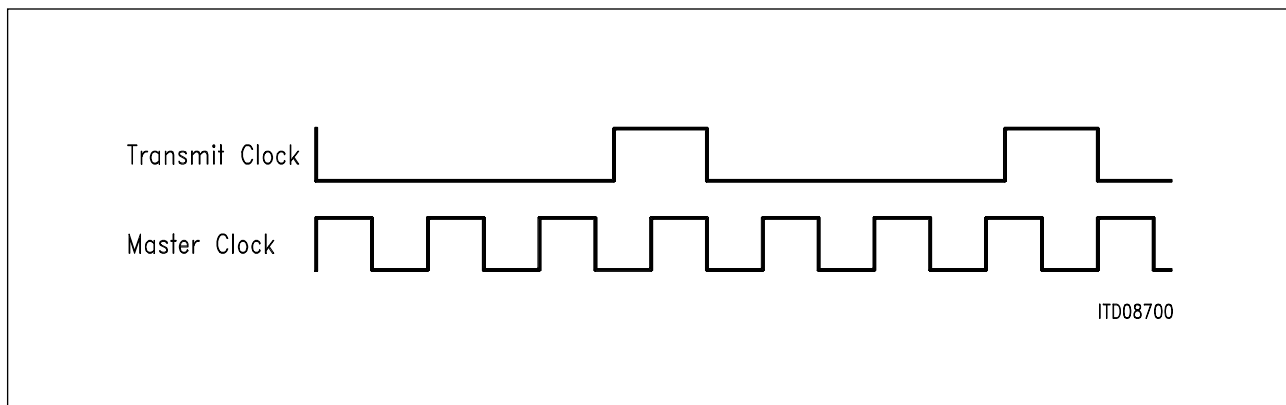

Figure 38
Long Low Phase of Transmit Clock for a Minimum of 2.5 Master Clock Cycles

Note 4: If one of the clock modes 0b, 4, 6 or 7 or the master clock is selected the internal oscillator (OSC) is enabled which allows connection of an external crystal to pins XTAL1-XTAL2. The output signal of the OSC can be used for one serial channel, or for both serial channels (independent baud rate generators and DPLLs). Moreover, XTAL1 alone can be used as input for an externally generated clock.

Serial Interface (layer-1 functions)**Selectable Enhanced Resolution Baud Rate Generator (V3.x)**

Two features are provided to allow the ESCC2 to work with higher XTAL rates and support higher transmission baud rates. The first is XTAL clock divide-by-4 logic and the second is the enhanced Baud Rate Generator (see also the BRG register description).

XTAL1-2 clock divide-by-4 function may optionally be selected (CCR4:MCK4) to feed the core logic and timer blocks. This allows the device to function with XTAL frequency up to 33 MHz. The baud rate generator is fed directly from the XTAL. It also allows the timer block to operate at the highest resolution. See also description for CCR4 and TIMR registers.

The enhanced baud rate generator has two modes of operation for added flexibility. The **normal mode** is as in previous versions of the device. For the **enhanced mode**, the Baud Rate generator bits BR0 ... BR9 are re-assigned to provide two stages of division.

The first stage divides the clock by integer number up to 63, whereas the second stage allows further division by powers of 2 (1, 2, 4, 8, 16, 32, 64, ..., 32768). See also description of the BRG register.

The Appendix shows baud rates derived from typical XTAL frequencies using the two modes of the baud rate generator.

Serial Interface (layer-1 functions)**8.2 Clock Recovery (DPLL)**

The ESCC2 offers the advantage of recovering the received clock from the received data by means of internal DPLL circuitry, thus eliminating the need to transfer additional clock information via the serial link. For this purpose, the DPLL is supplied with a 'reference clock' from the BRG which is 16 times the nominal data clock rate (clock mode 2, 3a, 6, 7a). The transmit clock may be obtained by dividing the output of the BRG by a constant factor of 16 (clock mode 2a, 6a; bit SSEL in CCR2 set) or also directly from the DPLL (clock mode 3a, 7a).

The main task of the DPLL is to derive a receive clock and to adjust its phase to the incoming data stream in order to enable optimal bit sampling.

The mechanism for clock recovery depends on the selected data encoding (refer to **chapter 8.4**).

The following functions have been implemented to facilitate a fast and reliable synchronization:

Interference Rejection and Spike Filtering

In the case where two or more edges appear in the data stream within a time period of 16 reference clocks, these are considered as interference and consequently no additional clock adjustment is performed.

Phase Adjustment

In the case where an edge appears in the data stream within the PA fields of the time window, the phase will be adjusted by 1/16 of the data clock.

Phase Shift (NRZ, NRZI only)

In the case where an edge appears in the data stream within the PS fields of the time window, a second sampling of the bit is forced and the phase is shifted by 180 degrees.

Note: Edges in all other parts of the time window will be ignored.

This operation facilitates a **fast** and reliable synchronization for most common applications. Above all, it implies a very fast synchronization because of the phase shift feature: one edge on the received data stream is enough for the DPLL to synchronize, thereby eliminating the need for synchronization patterns sometimes called preambles. However, in case of **extremely** high jitter of the incoming data stream the reliability of the clock recovery cannot be guaranteed.

The version 2 of ESCC2 offers the option to disable the Phase Shift function for NRZ and NRZI encodings by setting bit CCR3:PSD. In this case, the PA fields are extended as shown in **figure 39b**.

Serial Interface (layer-1 functions)

Now, the DPLL is more insensitive to high jitter amplitudes but needs **more time** to reach the optimal sampling position. To ensure correct data sampling preambles should precede the data information.

Figures 39a, 39b and 40 explain the DPLL algorithms used for the different data encodings.

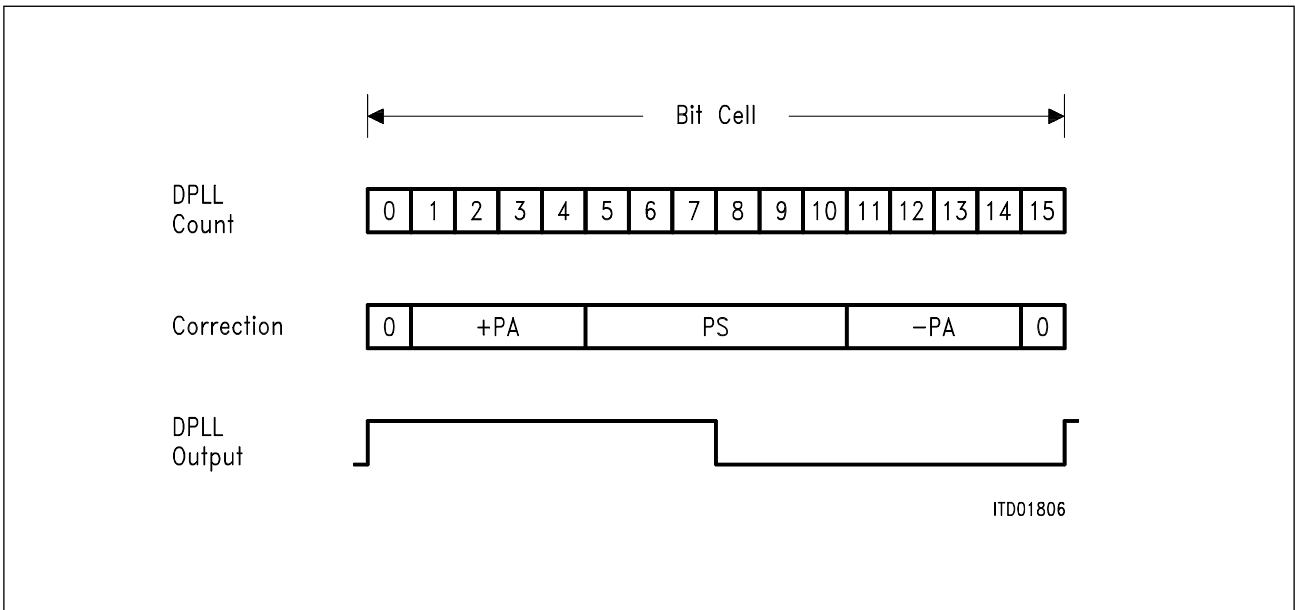

Figure 39a
DPLL Algorithm for NRZ and NRZI
Coding with Phase Shift Enabled (CCR3:PSD = '0')

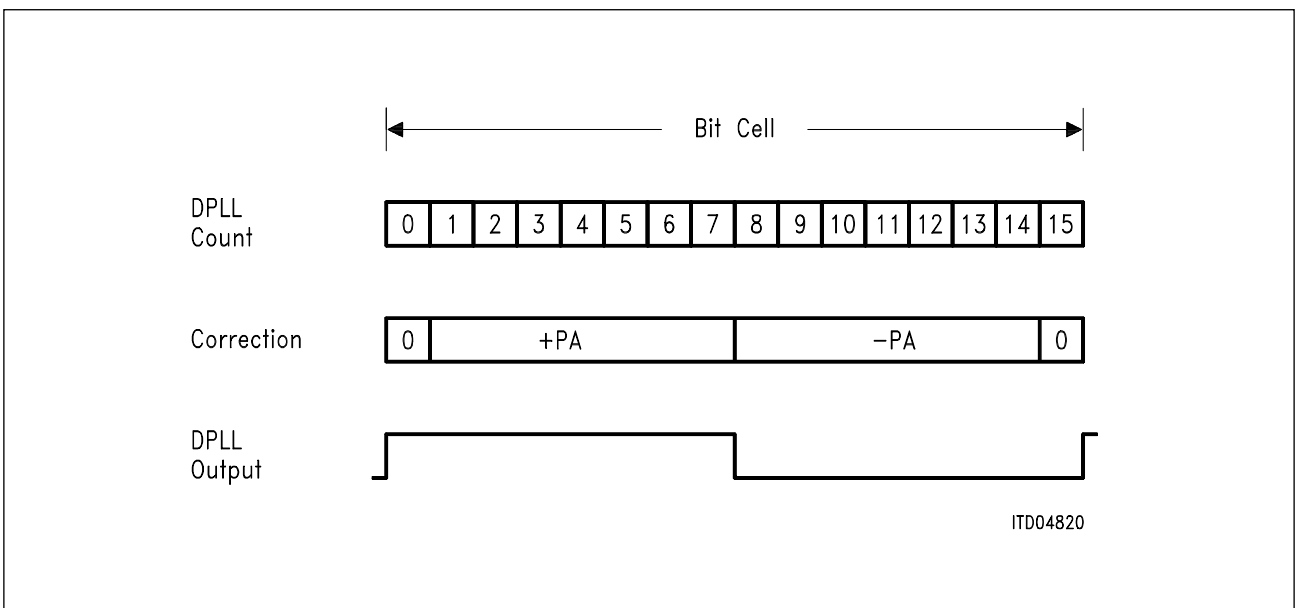

Figure 39b
DPLL Algorithm for NRZ and NRZI
Encoding with Phase Shift Disabled (CCR3:PSD = '1')

Serial Interface (layer-1 functions)

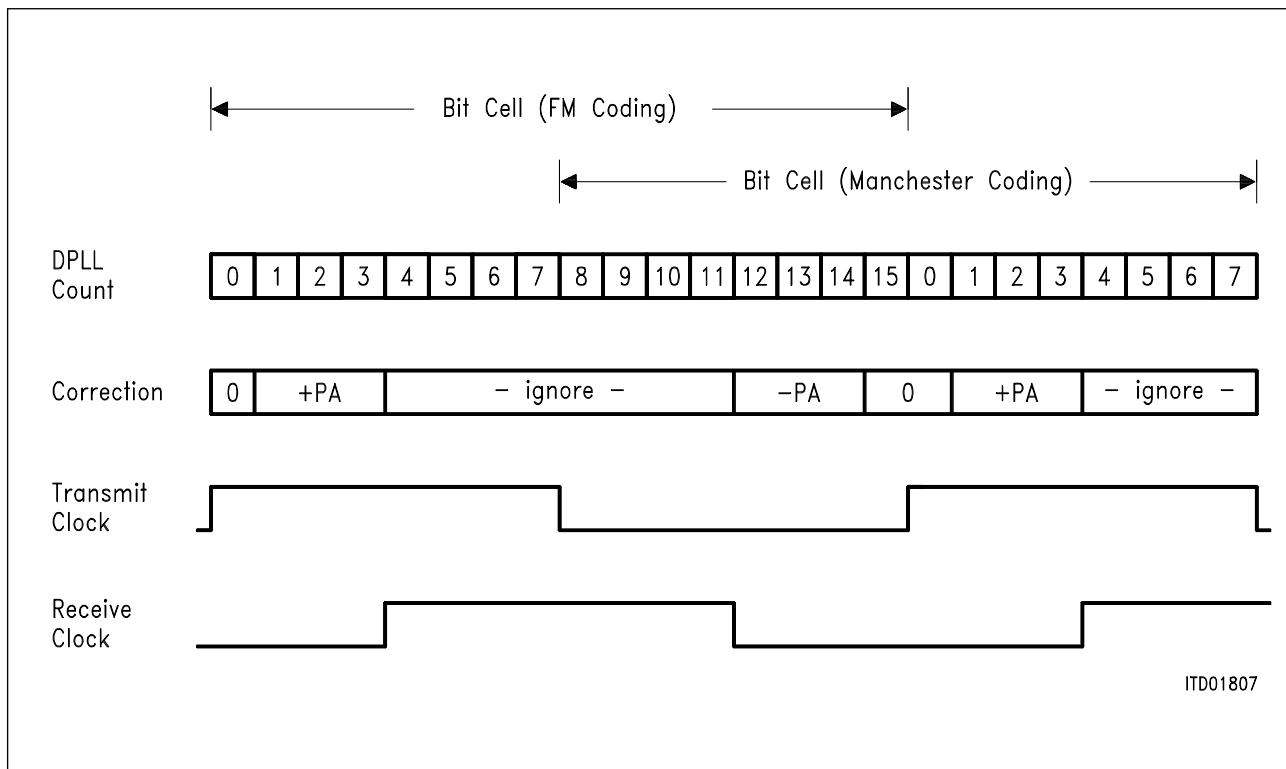

Figure 40
DPLL Algorithm for FM0, FM1 and Manchester Coding

To supervise correct function when using bi-phase encoding, a status flag and a maskable interrupt inform about synchronous/asynchronous state of the DPLL.

Serial Interface (layer-1 functions)**8.3 Bus Configuration**

Beside the point-to-point configuration, the ESCC2 effectively supports point-to-multipoint (pt-mpt, or bus) configurations by means of internal idle and collision detection/collision resolution methods.

In a pt-mpt configuration, comprising a central station (master) and several peripheral stations (slaves), or in a multimaster configuration (see **figure 16**), data transmission can be initiated by each station over a common transmit line (bus). In case more than one station attempt to transmit data simultaneously (collision), the bus has to be assigned to one station.

- In HDLC/SDLC mode, a collision-resolution procedure is implemented by the ESCC2. Bus assignment is based on a priority mechanism with rotating priorities. This allows each station a bus access within a predetermined maximum time delay (deterministic CSMA/CD), no matter how many transmitters are connected to the serial bus.
- In BISYNC mode, the collision-resolution is implemented by the microprocessor.
- In ASYNC mode, a bus configuration is not recommended.

Prerequisites for bus operation are:

- NRZ encoding
- 'OR'ing of data from every transmitter on the bus (this can be realized as a wired-OR, using the TxD open drain capability)
- Feedback of bus information (CxD input).

The bus configuration is selected via the CCR0 register.

Note: Central clock supply for each station is not necessary if both the receive and transmit clock is recovered by the DPLL (clock modes 3a, 7a). This minimizes the phase shift between the individual transmit clocks.

The bus mode can be operated independently of the clock mode, e.g. also during clock mode 1 (receive and transmit strobe).

8.3.1 Bus Access Procedure

The idle state of the bus is identified by eight or more consecutive '1's. When a device starts transmission of a frame, the bus is recognized to be busy by the other devices at the moment the first 'zero' is transmitted (e.g. first 'zero' of the opening flag in HDLC mode).

After the frame has been transmitted, the bus becomes available again (idle).

Note: If the bus is occupied by other transmitters and/or there is no transmit request in the ESCC2, logical '1' will be continuously transmitted on TxD.

Serial Interface (layer-1 functions)**8.3.2 Collisions**

During the transmission, the data transmitted on TxD is compared with the data on CxD. In case of a mismatch ('1' sent and '0' detected, or vice versa) data transmission is immediately aborted, and idle (logical '1') is transmitted.

HDLC/SDLC: Transmission will be initiated again by the ESCC2 as soon as possible if the first part of the frame is still present in the XFIFO. If not, an XMR interrupt is generated.

Since a 'zero' ('low') on the bus prevails over a '1' (high impedance) if a wired-OR connection is implemented, and since the address fields of the HDLC frames sent by different stations normally differ from one another, the fact that a collision has occurred will be detected prior to or at the latest within the address field. The frame of the transmitter with the highest temporary priority (determined by the address field) is not affected and is transmitted successfully. All other stations cease transmission immediately and return to bus monitoring state.

BISYNC: Transmitter and XFIFO are reset and pin TxD goes to '1'. The XMR interrupt is provided which requests the microprocessor to repeat the whole message or block of characters.

ASYNC: Bus configuration not recommended.

Note: If a wired-OR connection has been realized by an external pull-up resistor without decoupling, the data output (TxD) can be used as an open drain output and connected directly to the CxD input.

For correct identification as to which frame is aborted and thus has to be repeated after an XMR interrupt has occurred, the contents of XFIFO have to be unique, i.e. XFIFO should not contain data of more than one frame as it could happen when servicing is done after an XPR interrupt. For this purpose the All Sent interrupt (ISR1:ALLS) instead of XPR has to be used to trigger the loading of data (for the next frame) into XFIFO.

8.3.3 Priority (HDLC/SDLC mode only)

To ensure that all competing stations are given a fair access to the transmission medium, once a station has successfully completed the transmission of a frame, it is given a lower level of priority. This priority mechanism is based on the requirement that a station may attempt transmitting only when a determined number of consecutive '1's are detected on the bus.

Normally, a transmission can start when eight consecutive '1's on the bus are detected (through pin CxD). When an HDLC frame has been successfully transmitted, the internal priority class is decreased. Thus, in order for the same station to be able to transmit another frame, ten consecutive '1's on the bus must be detected. This guarantees that the transmission requests of other stations are satisfied before the same station is

Serial Interface (layer-1 functions)

allowed a second bus access. When ten consecutive '1's have been detected, transmission is allowed again and the priority class is increased (to eight '1's).

Inside a priority class, the order of transmission (individual priority) is based on the HDLC address, as explained in the preceding paragraph. Thus, when a collision occurs, it is always the station transmitting the only 'zero' (i.e. all other stations transmit a 'one') in a bit position of the address field that wins, all other stations cease transmission immediately.

8.3.4 Timing Modes

If a bus configuration has been selected, the ESCC2 provides two timing modes, differing in the time interval between sending data and evaluation of the transmitted data for collision detection.

1. Timing mode 1 (CCR0: SC1, SC0 = '01')
Data is output with the rising edge of the transmit clock via the TxD pin, and evaluated 1/2 a clock period later at the CxD pin with the falling clock edge.
2. Timing mode 2 (CCR0: SC1, SC0 = '11')
Data is output with the falling clock edge and evaluated with the next falling clock edge. Thus one complete clock period is available between the instant when data is output and collision detection.

8.3.5 Functions of $\overline{\text{RTS}}$ Output

In clock modes 0, 1 and 4, the $\overline{\text{RTS}}$ output can be programmed via CCR2 (SOC bits) to be active when data (frame or character) is being transmitted. This signal is delayed by one clock period with respect to the data output TxD, and marks all data bits that could be transmitted without collision. In this way a configuration may be implemented in which the bus access is resolved on a local basis (collision bus) and where the data are sent one clock period later on a separate transmission line.

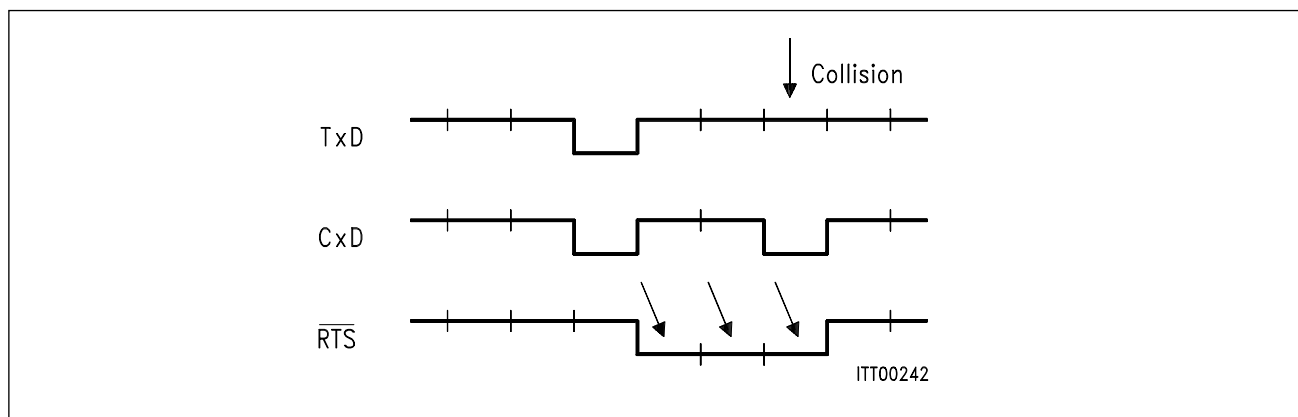

Figure 41
Request-to-Send in Bus Operation

*Note: For details on the functions of the $\overline{\text{RTS}}$ pin refer to **chapter 8.5**.*

Serial Interface (layer-1 functions)

8.4 Data Encoding

The ESCC2 supports the following coding schemes for serial data:

- Non-Return-To-Zero (NRZ)
- Non-Return-To-Zero-Inverted (NRZI)
- FM0 (also known as Bi-Phase Space)
- FM1 (also known as Bi-Phase Mark)
- Manchester (also known as Bi-Phase)

NRZ: The signal level corresponds to the value of the data bit. By programming bit DIV (CCR2 register) the ESCC2 may made to transmit and receive data inverted.

NRZI: A logical '0' is indicated by a transition and a logical '1' by no transition at the beginning of the bit cell.

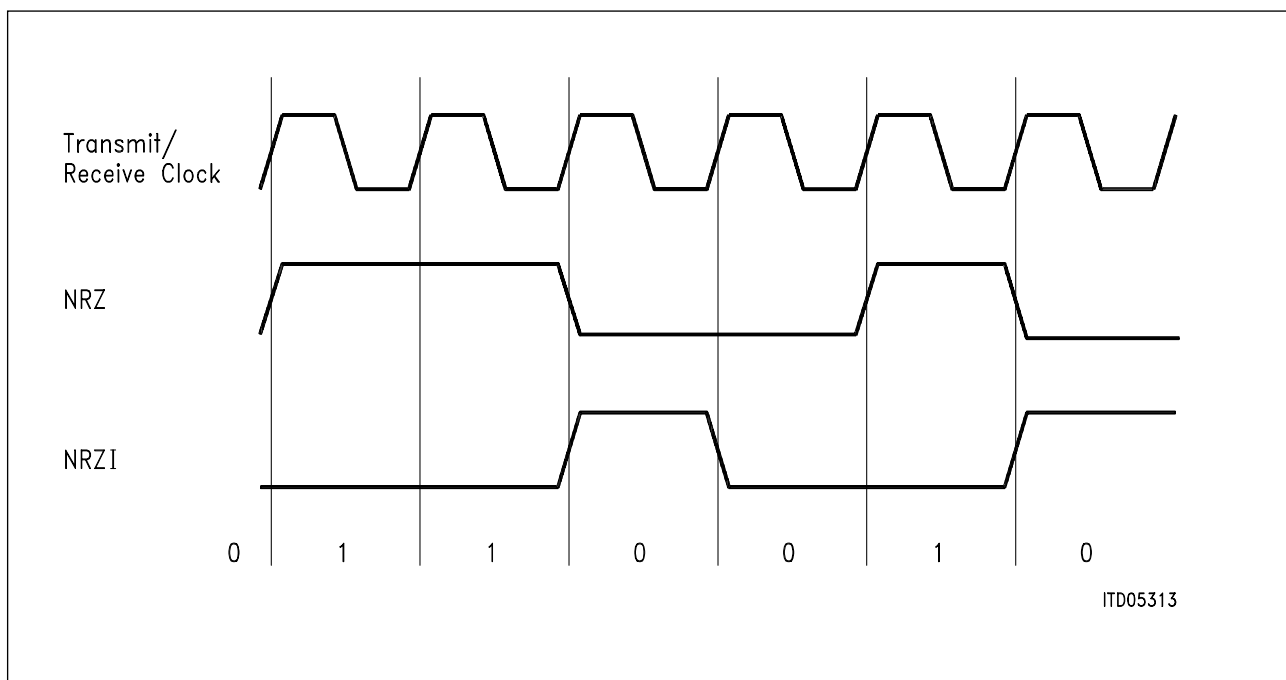

Figure 42
NRZ and NRZI Data Encoding

Serial Interface (layer-1 functions)

FM0: An edge occurs at the beginning of every bit cell. A logical '0' has an additional edge in the center of the bit cell, a logical '1' has none. The transmit clock precedes the receive clock by 90°.

FM1: An edge occurs at the beginning of every bit cell. A logical '1' has an additional edge in the center of the bit cell, a logical '0' has none. The transmit clock precedes the receive clock by 90°.

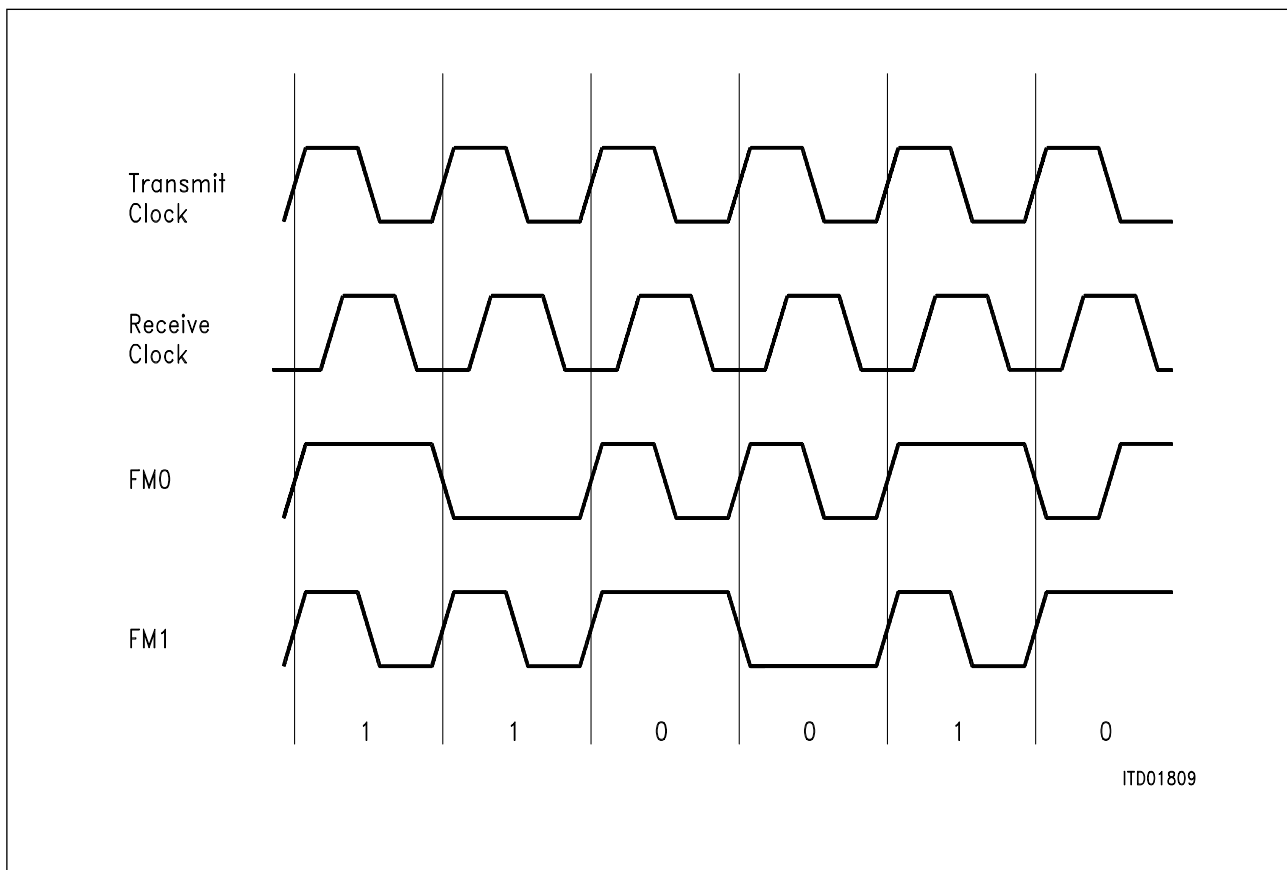

Figure 43
FM0 and FM1 Data Encoding

Serial Interface (layer-1 functions)

Manchester: In the first half of the bit cell the physical signal level corresponds to the logical value of the data bit. At the center of the bit cell this level is inverted. The transmit clock precedes the receive clock by 90°. The bit cell is shifted by 180° in comparison with FM coding.

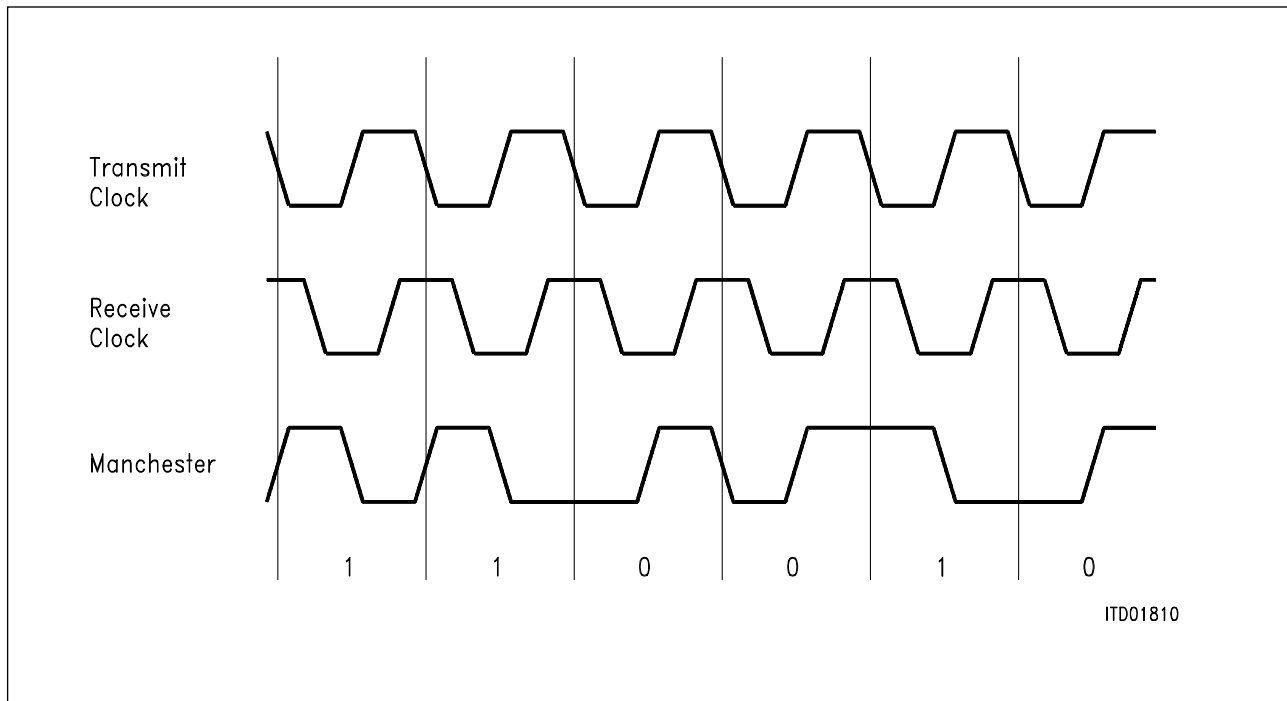

Figure 44
Manchester Data Encoding

Serial Interface (layer-1 functions)

8.5 Modem Control Functions ($\overline{\text{RTS/CTS}}$, CD)8.5.1 $\overline{\text{RTS/CTS}}$ Handshaking

The ESCC2 provides two pins ($\overline{\text{RTS}}$, $\overline{\text{CTS}}$) per serial channel supporting the standard $\overline{\text{RTS}}$ modem handshaking procedure for transmission control.

A transmit request will be indicated by outputting logical '0' on the request-to-send output ($\overline{\text{RTS}}$). It is also possible to control the $\overline{\text{RTS}}$ output by software. After having received the permission to transmit ($\overline{\text{CTS}}$) the ESCC2 starts data transmission.

HDLC/SDLC and BISYNC: In the case where permission to transmit is withdrawn in the course of transmission, the frame is aborted and IDLE is sent. After transmission is enabled again by re-activation of $\overline{\text{CTS}}$, and if the beginning of the frame is still available in the ESCC2, the frame will be re-transmitted (self-recovery). However, if the permission to transmit is withdrawn after the data in the first XFIFO pool has been completely transmitted and the pool is released, the transmitter and the XFIFO are reset, the $\overline{\text{RTS}}$ output is deactivated and an interrupt (XMR) is generated.

Note: For correct identification as to which frame is aborted and thus has to be repeated after an XMR interrupt has occurred, the contents of XFIFO have to be unique, i.e. XFIFO should not contain data of more than one frame, which could happen if transmission of a new frame is started by loading new data in XFIFO and issuing a transmit command upon reception of XPR interrupt. For this purpose the All Sent interrupt (ISR1: ALLS) instead of XPR has to be used to trigger the loading of data (for the next frame) into XFIFO.

ASYNC: In the case where permission to transmit is withdrawn, transmission of the current character is completed. After that, IDLE is sent. After transmission is enabled again by re-activation of $\overline{\text{CTS}}$, the next available character is sent out.

Note: In the case where permission to transmit is not required, the $\overline{\text{CTS}}$ input can be connected directly to V_{SS} .

Additionally, any transition on the $\overline{\text{CTS}}$ input pin will generate an interrupt indicated via the ISR1 register, if this function is enabled by setting the CSC bit in the IMR1 register.

Serial Interface (layer-1 functions)

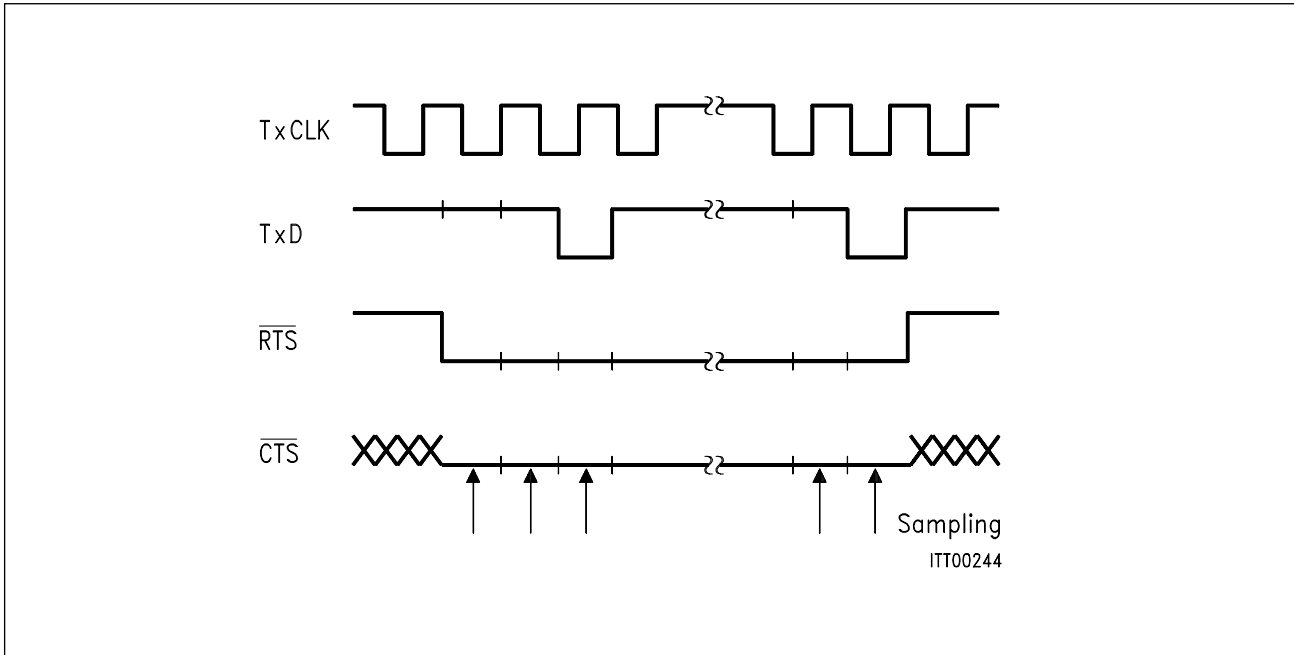

Figure 45
RTS-CTS Handshaking

Beyond this standard $\overline{\text{RTS}}$ function, signifying a transmission request of a frame (Request To Send), the $\overline{\text{RTS}}$ output may be programmed for a special function via SOC1, SOC0 bits in the CCR2 register, provided the serial channel is operating in a bus configuration in clock mode 0 or 1.

- If SOC1, SOC0 bits are set to '11', the $\overline{\text{RTS}}$ output is active (= low) during the reception of a frame.
- If SOC1, SOC0 bits are set to '10', the $\overline{\text{RTS}}$ output function is disabled and the $\overline{\text{RTS}}$ pin remains always high.

8.5.2 Carrier Detect (CD) Receiver Control

Similar to the $\overline{\text{RTS}}/\overline{\text{CTS}}$ control for the transmitter, the ESCC2 supports the carrier detect modem control function for the serial receivers if the Carrier Detect Auto Start (CAS) function is programmed by setting the CAS bit in the XBCH register. This function is always available in clock modes 0, 2, 3, 4, 6, 7 via the CD pin. In clock mode 1 the CD function is not supported. See **table 5** for an overview.

If the CAS function is selected, the receiver is enabled and data reception is started when the CD input is detected to be high. If CD input is set to 'low', reception of the current character (byte) is still completed.

Serial Interface (layer-1 functions)**8.6 Test Mode**

To provide for fast and efficient testing, the ESCC2 can be operated in a test mode by setting the TLP bit in the MODE register.

The on-chip serial input and output (TxD-RxD) are connected, generating a local loopback.

As a result, the user can perform a self-test of the ESCC2.

8.7 Universal Port

A general purpose 8-bit port is provided on pins P0 ... P7. Every pin is separately programmable via the Port Configuration Register PCR to operate as an output or an input.

If defined as output, the state of the pin is directly controlled via Port Value Register PVR. A read-back is also provided.

If defined as input, the state of the pin is monitored. The value is readable via PVR. All changes may be (if desired) indicated via interrupt. Assigned registers: Port Interrupt Status register (PIS) and Port Interrupt Mask register (PIM).

9 Operational Description

9.1 Reset

The ESCC2 is forced into the reset state if the RES pin is set 'high' for at least 5 microseconds. During RESET, the ESCC2 is temporarily in the power-up mode, and a subset of the registers is initialized with defined values.

During hardware reset

- all uni-directional output stages are in high-impedance state,
- all bi-directional output stages (data bus) are in high-impedance state if signals \overline{RD} and \overline{INTA} are 'high',
- output XTAL2 is high-impedance if input XTAL1 is 'high' (the internal oscillator is disabled during reset).

After RESET, the ESCC2 is in power-down mode, and the following registers contain defined values:

Register	Reset Value	Meaning
CCR0	00 _H	<ul style="list-style-type: none"> – power-down mode – HDLC-/SDLC mode – NRZ coding
CCR1	00 _H	<ul style="list-style-type: none"> – no shared flags – no SDLC loop function – TxD pins are open drain outputs – pt-pt with IDLE as interframe time fill – clock mode 0
CCR2	00 _H	<ul style="list-style-type: none"> – \overline{RTS} pin standard function – READ/WRITE exchange disabled – CRC-32 disabled – no data inversion
CCR3	00 _H	<ul style="list-style-type: none"> – no preambles – CRC reset level is FFFF_H – no ADDRESS to RFIFO – no CRC-bytes to RFIFO – transmit CRC OFF
MODE	00 _H	<ul style="list-style-type: none"> – auto-mode with 1 byte address field – external timer mode, timer resolution: k = 32768 – receiver inactive – \overline{RTS} output controlled by ESCC2 – no test loop

Operational Description

Register	Reset Value	Meaning
IMR0 IMR1 PIM	FF _H FF _H FF _H	– all interrupts masked
IPC	00 _H	– interrupt pin INT is an open drain output – Slave Cascading mode is enabled – slave address is set to 00 _H
PCR	FF _H	– all pins of the Universal Port are inputs
IVA	00 _H	– interrupt vector address is set to 00 _H
PRE	00 _H	– preamble value is set to 00 _H
XBCH	00 _H	– interrupt controlled data transfer (DMA disabled) – full-duplex LAPB/LAPD operation of LAP controller – carrier detect auto start of receiver disabled
STAR	48 _H	– XFIFO write enable – receive line inactive – no commands executing
AML/MXN AMH/MXF	00 _H 00 _H	– address mask disabled
TSAX TSAR	00 _H	– time-slot number: 00 _H – clock shift (together with CCR2 = 00 _H): 00 _H
XCCR RCCR	00 _H	– 1-bit time-slot

9.2 Initialization

After Reset the CPU has to write a minimum set of registers and an optional set dependent on the required features and operating modes.

First, the serial mode, the configuration of the serial port and the clock mode have to be defined via the CCR0 and CCR1 registers. The clock mode must be set before power-up (CCR1). The CPU may switch the ESCC2 between power-up and power-down mode. This has no influence upon the contents of the registers, i.e. the internal state remains stored. In power-down mode however, all internal clocks and the oscillator circuitry are disabled, no interrupts are forwarded to the CPU (interrupts of universal port excluded). This state can be used as a standby mode, when the ESCC2 is temporarily not used, thus substantially reducing power consumption.

The ESCC2 should usually be initialized in power-down mode.

The need for programming further registers depends on the selected features (serial mode, clock mode specific features, operating mode, address mode, user demands).

Table 6 gives an overview about initialization of the control registers.

Table 6
Initialization of ESCC2

Item	Registers	Comment
Clock Mode clock mode specific features	CCR0, CCR1 BGR, CCR2 TSAR, TSAX XCCR, RCCR	For master clock mode for clock modes 2, 3, 4, 6, 7 for clock mode 5
Serial Mode	CCR0	
Serial Port Configuration	CCR0 CCR1 CCR2	Encoding output driver select data inversion, RxD ↔ TxD

Operational Description

Table 6
Initialization of ESCC2 (cont'd)

Item	Registers	Comment
Serial Mode Specific Features		
HDLC/SDLC	MODE, TIMR XAD1, XAD2 RAH1, RAH2 RAL1, RAL2 XBCH CCR1 CCR2 CCR3 CCR4 PRE RLCR	Refer to table 7 NRM mode shared flags, ITF/OIN CRC32 CRC reset level, preamble CRC/ADDRESS-Bytes to RFIFO RFIFO Threshold preamble receive length check
ASYNC	CCR1 DAFO RFC TCR	bit clock rate data format RFIFO configuration termination character XON character XOFF character
BISYNC	MODE SYNL, SYNH DAFO RFC CCR3 PRE TCR	BI-/MONO-Sync, SLEN SYN character data format RFIFO configuration CRC, preamble preamble termination character

User Demands

Modem control lines	MODE, CCR2 XBCH	$\overline{\text{RTS}}$ pins CD pins
Parallel port	PCR	port configuration

Operational Description

Table 6
Initialization of ESCC2 (cont'd)

Item	Registers	Comment
Interrupt features	IPC IVA IMR0, IMR1 PIM	port configuration, slave addr. cascading mode Interrupt vector address interrupt masks
DMA features	XBCH CCR2	DMA read/write exchange
Timer (external mode)	MODE, TIMR	

Table 7
HDLC Specific Register Setup

Operating Mode	Address Mode	2 Byte Address Field (MODE:ADM = '1')	1 Byte Address Field (MODE:ADM = '0')
	Auto		RAH2 RAH2 RAL1 RAL2 AML AMH
Non Auto		RAH2 RAH2 RAL1 RAL2 AML AMH	RAH1 set to 00 _H – RAL1 RAL2 AML
Transparent		RAH1 RAH2 AMH	– –

9.3 Operational Phase

After having performed the initialization, the CPU switches each individual channel of the ESCC2 into operational phase by setting the PU bit in the CCR0 register.

Initially, the CPU should bring the transmitter and receiver into a defined state by issuing a Transmitter Reset command (CMDR:XRES) and a Receiver Reset command (CMDR:RHR in HDLC/SDLC mode, CMDR:RRES in ASYNC and BISYNC mode). If data reception should be performed, the receiver must be activated by setting the bit MODE:RAC.

If no 'Clear To Send' function is provided via a modem, the $\overline{\text{CTS}}$ pin(s) of the ESCC2 must be connected directly to ground in order to enable data transmission.

Now the ESCC2 is ready to transmit and receive data. Control of data transfer is mainly done by commands from CPU to ESCC2 via the CMDR register, and by interrupt indications from ESCC2 to CPU. Additional status information, which does not trigger an interrupt, is available in the STAR register.

9.3.1 Data Transmission

9.3.1.1 Interrupt Mode

In transmit direction 2×32 byte FIFO buffers (transmit pools) are provided for each channel. After checking the XFIFO status by polling the Transmit FIFO Write Enable bit (XFW in STAR register) or after a Transmit Pool Ready (XPR) interrupt, up to 32 bytes may be entered by the CPU into the XFIFO.

HDLC/SDLC: The transmission of a frame can be started by issuing a XTF or XIF command via the CMDR register. If enabled, a specified number of preambles (refer to registers CCR3 and PRE) are sent out optionally before transmission of the current frame starts. If the transmit command does not include an end of message indication (CMDR: XME), the ESCC2 will repeatedly request for the next data block by means of a XPR interrupt as soon as no more than 32 bytes are stored in the XFIFO, i.e. a 32-byte pool is accessible to the CPU.

This process will be repeated until the CPU indicates the end of message per XME command, after which frame transmission is finished correctly by appending the CRC and closing flag sequence. Consecutive frames may share a flag (enabled via CCR1:SFLG) or may be transmitted as back-to-back frames, if service of XFIFO is quick enough.

In case no more data is available in the XFIFO prior to the arrival of XME, the transmission of the frame is terminated with an abort sequence and the CPU is notified per interrupt (ISR1:XDU). The frame may also be aborted per software (CMDR: XRES). The data transmission sequence, from the CPU's point of view, is outlined in **figure 46**.

Operational Description

ASYNCR: The transmission of character(s) can be started by issuing a XF command via the CMDR register. The ESCC2 will repeatedly request for the next data block by means of a XPR interrupt as soon as no more than 32 bytes are stored in the XFIFO, i.e. a 32-byte pool is accessible to the CPU. Transmission may be aborted per software (CMDR:XRES).

BISYNCR: The transmission of a block can be started by issuing a XF command via the CMDR register. Further handling of data transmission with respect to preamble transmission and command XME is similar to HDLC/SDLC mode. After XME command has been issued, the block is finished by appending the internally generated CRC if enabled (refer to description of register CCR3).

In case no more data is available in the XFIFO prior to the arrival of XME, the transmission of the block is terminated with IDLE and the CPU is notified per interrupt (ISR1:XDU). The block may also be aborted per software (CMDR:XRES). The data transmission flow, from the CPU's point of view, is outlined in **figure 46**.

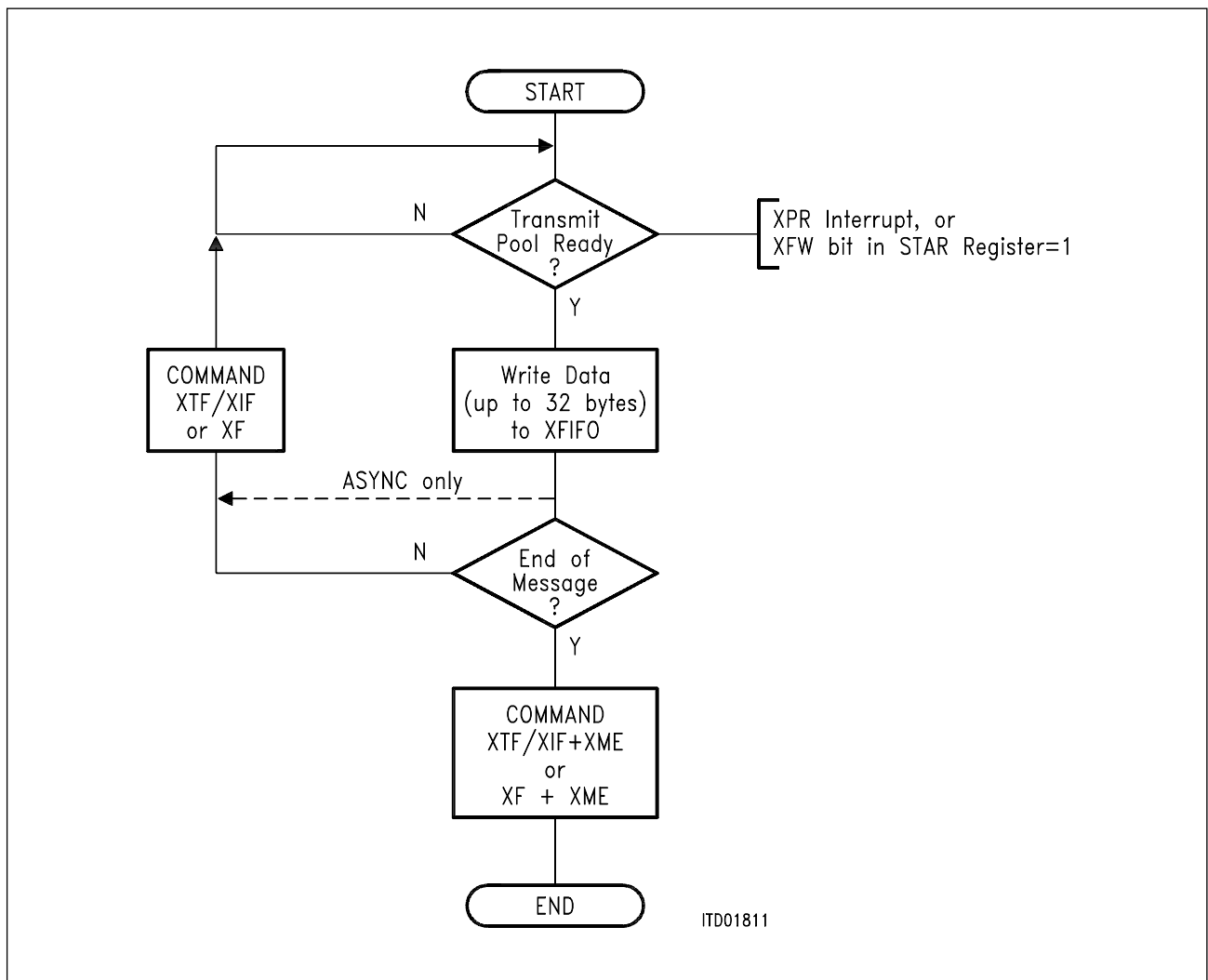

Figure 46
Interrupt Driven Data Transmission (Flow Diagram)

Operational Description

The activities at both serial and CPU interface during frame transmission (supposed frame length = 70 bytes) are shown in **figure 47**.

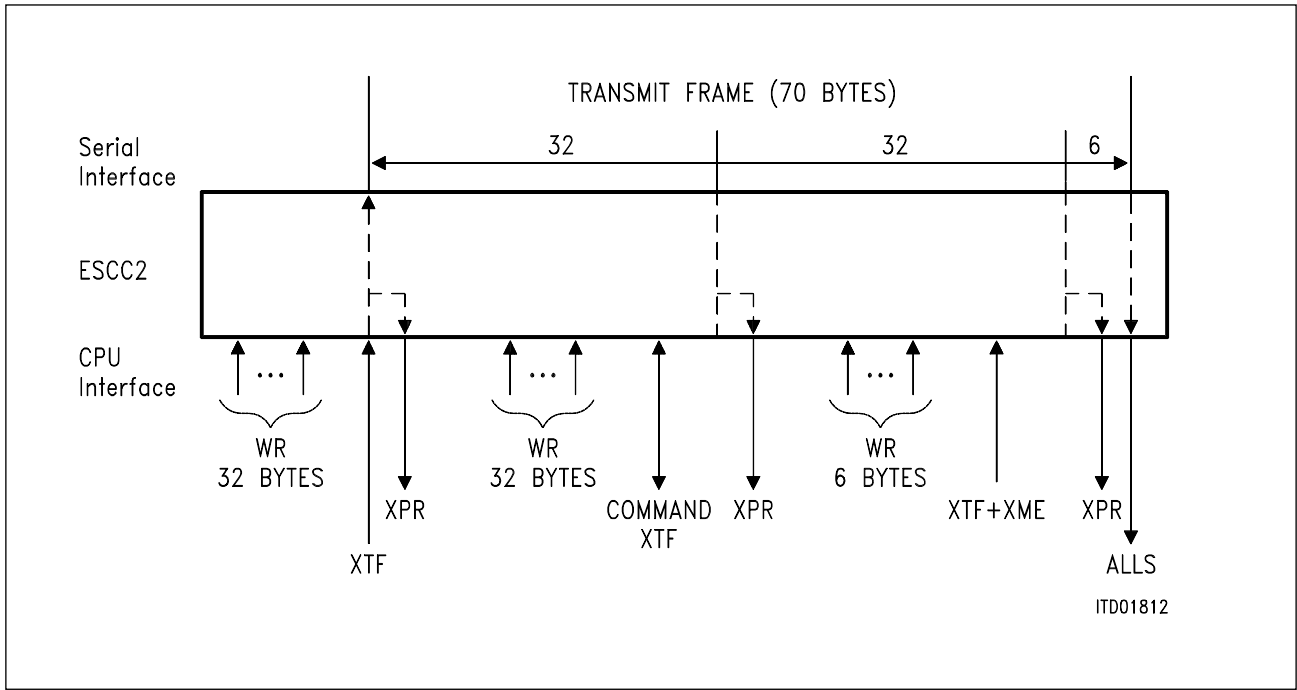

Figure 47
Interrupt Driven Transmission Sequence Example (HDLC)

Operational Description

9.3.1.2 DMA Mode

Prior to data transmission, the length of the next frame (or the next block of characters) to be transmitted must be programmed via the Transmit Byte Count Registers (XBCH, XBCL). The resulting byte count equals the programmed value plus one byte, i.e. since 12 bits are provided via XBCH, XBCL (XBC11 ... XBC0) a frame length of 1 up to 4096 bytes (4 Kbytes) can be selected.

After this, data transmission can be initiated by command (XTF or XIF in HDLC/SDLC mode, XF in ASYNC and BISYNC mode). The ESCC2 will then autonomously request the correct amount of write cycles by activating the DRT line for as long as necessary, taking into account the selected data bus width (i.e. byte or word accesses). For a frame length of $L = (n \times 32 + \text{remainder})$ bytes ($n = 0, 1, \dots, 128$), block data transfers of 32 bytes/16 words or remainder ($\div 2$) bytes (words) are requested whenever a 32-byte FIFO half (transmit pool) is empty and accessible to the DMA controller.

The following figure gives an example of a DMA driven transmission sequence with a supposed frame length of 70 bytes, i.e. programmed transmit byte count (XCNT) equal to 69 bytes.

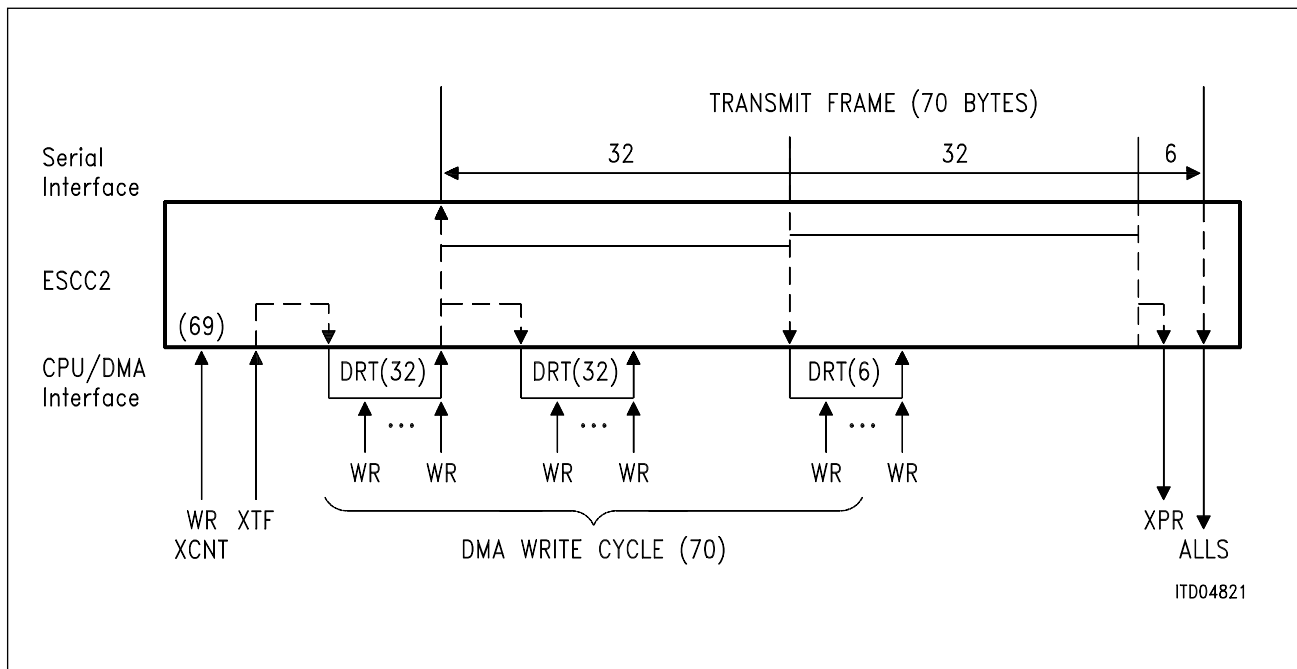

Figure 48
DMA Driven Transmission Sequence Example (HDLC)

9.3.2 Data Reception

9.3.2.1 Interrupt Mode

Also 2 × 32 byte FIFO buffers (receive pools) are provided for each channel in receive direction.

There are different interrupt indications concerned with the reception of data:

HDLC/SDLC

- RPF (Receive Pool Full) interrupt, indicating that a 32-byte block of data can be read from RFIFO and the received message is not yet complete.
- RME (Receive Message End) interrupt, indicating that the reception of one message is completed, i.e. either
 - one message with less than 32 bytes, or the
 - last part of a message with more than 32 bytes is stored in the RFIFO.

In addition to the message end (RME) interrupt the following information about the received frame is stored by the ESCC2 in special registers and/or RFIFO:

**Table 8
Status Information after RME Interrupt**

Length of message (bytes)	⇒ RBCH, RBCL	register
Address combination and/or	⇒ RSTA	RFIFO: last byte
Address field	⇒ RAL1	RFIFO
Control field	⇒ RHCR	RFIFO
Type of frame (COMMAND/RESPONSE)	⇒ RSTA	RFIFO: last byte
CRC result (good/bad)	⇒ RSTA	RFIFO: last byte
Valid frame (yes/no)	⇒ RSTA	RFIFO: last byte
ABORT sequence recognized (yes/no)	⇒ RSTA	RFIFO: last byte
Data overflow	⇒ RSTA	RFIFO: last byte

ASYNC, BISYNC

- RPF (Receive Pool Full) interrupt, indicating that a specified number of bytes (refer to register RFC) can be read from RFIFO.
- TCD (Termination Character Detected) interrupt, indicating that reception has been terminated by reception of a specified character (refer to register TCR and bit RFC:TCDE).

Additionally, the CPU can have access to contents of RFIFO without having received an interrupt (and thereby causing TCD to occur) by issuing the RFIFO Read command (CMDR:RFRD).

Operational Description

In addition to every received character the assigned status information Parity bit (0/1), Parity Error (yes/no), Framing Error (yes/no, ASYNC only!) is optionally stored in RFIFO. In addition to the end conditions (TCD interrupt or after RFRD command) the length of the last received data block is stored in register RBCL.

Note: For all serial modes: After the received data has been read from the RFIFO, this must be explicitly acknowledged by the CPU issuing a RMC (Receive Message Complete) command. The CPU has to handle the RPF interrupt before additional 32 bytes are received via the serial interface which would cause a 'Receive Data Overflow' condition.

The following figure gives an example of an interrupt controlled reception sequence, assuming that a 'long' frame (66 bytes) followed by two short frames (6 bytes each) is received.

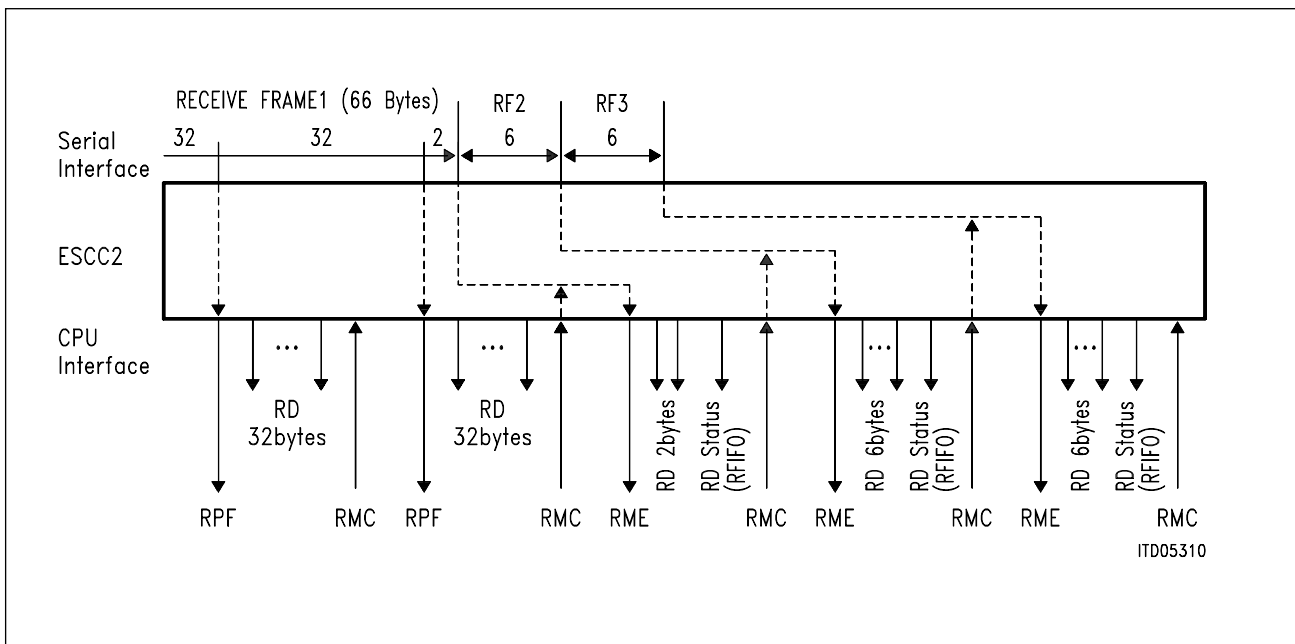

Figure 49
Interrupt Driven Reception Sequence Example (HDLC)

9.3.2.2 DMA Mode

If the RFIFO contains 32 bytes, the ESCC2 autonomously requests a block data transfer by DMA by activating the DRR line for as long as the start of the 32nd (byte access) or 16th (word access) read cycle. This forces the DMA controller to continuously perform bus cycles till 32 bytes are transferred from the ESCC2 to the system memory. If the RFIFO contains less than 32 bytes, the ESCC2 requests the correct amount of transfer cycles depending on the contents of the RFIFO and taking into account the selected bus width.

Note: All available status information for each frame/data block after the end conditions (RME or TCD) and for each character is the same as described above.

After the DMA controller has been set up for the reception of the next frame, the CPU must issue a RMC command to acknowledge the completion of received data processing. The ESCC2 will not initiate further DMA cycles by activating the DRR line prior to the reception of RMC.

In HDLC/SDLC mode the RECEIVE STATUS REGISTER is automatically read from the RFIFO with the last DMA-READ cycle of the received frame.

The status information after a RME interrupt is the same as in the interrupt driven mode.

The following figure gives an example of a DMA controlled reception sequence, supposing that a 'long' frame (66 bytes) followed by two short frames (6 bytes each) is received.

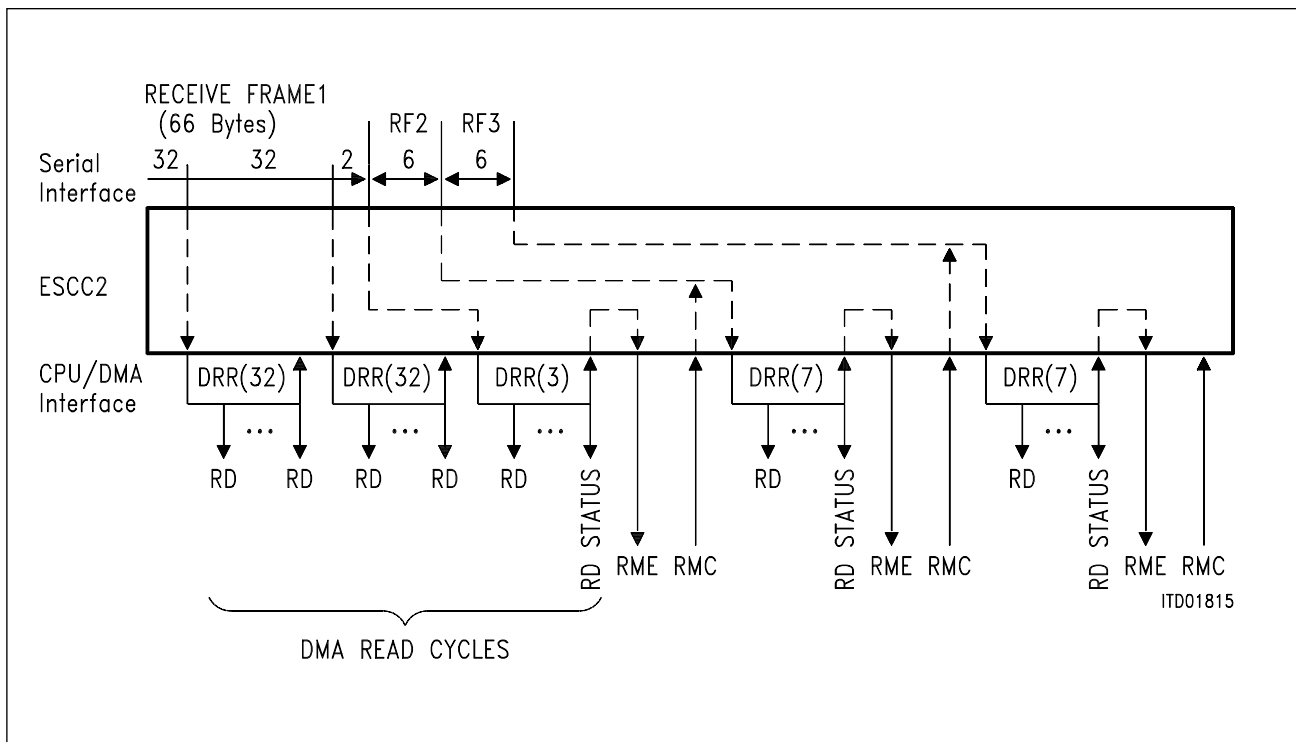

Figure 50
DMA Driven Reception Sequence Example (HDLC)

Detailed Register Description

10 Detailed Register Description

10.1 Status/Control Registers in HDLC Mode

10.1.1 Register Addresses

Address (A0 ... A6)		Register		Meaning	Refer to Page
Channel		Read	Write		
A	B				
00	40	RFIFO	XFIFO	Receive/Transmit FIFO	114/115
.	.				
.	.				
.	.				
.	.				
1F	5F				
20	60	STAR	CMDR	Status Register/Command Register	115/117
21	61	RSTA	PRE	Receive Status/Preamble Register	120/119
22	62	MODE		Mode Register	122
23	63	TIMR		Timer Register	124
24	64	XAD1		Transmit Address 1	126
25	65	XAD2		Transmit Address 2	127
26	66	–	RAH1	Receive Address High 1	128
27	67	–	RAH2	Receive Address High 2	129
28	68	RAL1		Receive Address Low 1	130
29	69	RHCR	RAL2	Receive HDLC Control/Receive Address Low 2	131/131
2A	6A	RBCL	XBCL	Receive Byte Count Low/Transmit Byte Count Low	131/132
2B	6B	RBCH	XBCH	Receive/Transmit Byte Count High	132/133

Detailed Register Description

10.1.1 Register Addresses (cont'd)

Address (A0 ... A6)		Register		Meaning	Refer to Page
Channel		Read	Write		
A	B				
2C	6C	CCR0		Channel Configuration Register 0	134
2D	6D	CCR1		Channel Configuration Register 1	135
2E	6E	CCR2		Channel Configuration Register 2	137
2F	6F	CCR3		Channel Configuration Register 3	139
30	70	–	TSAX	Time-slot Assignment Register Transmit	141
31	71	–	TSAR	Time-slot Assignment Register Receive	141
32	72	–	XCCR	Transmit Channel Capacity Register	142
33	73	–	RCCR	Receive Channel Capacity Register	142
34	74	VSTR	BGR	Version Status/Baud Rate Generator Register	143/144
35	75	–	RLCR	Receive Frame Length Check	145
36	76	–	AML	Address Mask Low	145
37	77	–	AMH	Address Mask High	146
38	78	GIS ¹⁾	IVA ¹⁾	Global Interrupt Status/Interrupt Vector Address	146/147
39	79	IPC ¹⁾		Interrupt Port Configuration	148
3A	7A	ISR0	IMR0	Interrupt Status 0/Interrupt Mask 0	149/154
3B	7B	ISR1	IMR1	Interrupt Status 1/Interrupt Mask 1	151/154
3C	7C	PVR		Port Value Register	154
3D	7D	PIS ¹⁾	PIM ¹⁾	Port Interrupt Status/Port Interrupt Mask	155/155
3E	7E	PCR ¹⁾		Port Configuration Register	156
3F	7F	CCR4		Channel Configuration Register 4	157

¹⁾ Both channel assigned addresses enable access to the same register(s).

*Note: Read access to unused register addresses: value should be ignored,
Write access to unused register addresses: should be avoided, or set to '00_H'.*

Detailed Register Description

XRNR ...	Transmit RNR (significant in auto-mode only!) Indicates the status of the ESCC2. 0 ... receiver ready 1 ... receiver not ready
RRNR ...	Received RNR (significant in auto-mode only!) Indicates the status of the remote station. 0 ... receiver ready 1 ... receiver not ready
RLI ...	Receive Line Inactive Neither FLAGs as interframe time-fill nor frames are received via the receive line. <i>Note: Significant only in point-to-point configurations.</i>
CEC ...	Command Executing 0 ... no command is currently being executed, the CMDR register can be written to. 1 ... a command (written previously to CMDR) is currently being executed, no further command can be temporarily written in CMDR register. <i>Note: CEC will be active at most 2.5 transmit clock (or master clock) periods. If the ESCC2 is in power-down mode CEC will stay active.</i>
CTS ...	Clear To Send State This bit indicates the state of the $\overline{\text{CTS}}$ pin. 0 ... CTS is inactive ('high') 1 ... CTS is active ('low')
WFA ...	Wait For Acknowledgement (significant in auto-mode only!) Indicates the 'Wait for I-frame Acknowledgement' status of ESCC2.

Detailed Register Description

Command Register (CMDR)

Access: write address: ch-A: 20_H
ch-B: 60_H

Value after RESET: 00_H

	7						0	
CMDR	RMC	RHR	RNR/ XREP	STI	XTF	XIF	XME	XRES

RMC ... Receive Message Complete
 Confirmation from CPU to ESCC2 that the current frame or data block has been fetched following an RPF or RME interrupt, thus the occupied space in the RFIFO can be released.
Note: In DMA Mode, this command has to be issued after an RME interrupt, to enable the generation of further receiver DMA requests.

RHR ... Reset HDLC Receiver
 All data in the RFIFO and the HDLC receiver is deleted. In auto-mode, additionally the transmit and receive sequence number counters are reset.

RNR/XREP ... Receiver Not Ready/Transmission Repeat
 The function of this command depends on the selected operation mode (MDS1, MDS0, ADM bit in MODE):

- auto mode: RNR
 Determines the status of the ESCC2 receiver, i.e. whether a received frame is acknowledged via an RR or RNR supervisory frame in auto-mode.
 0 ... Receiver Ready (RR)
 1 ... Receiver Not Ready (RNR)
- extended transparent mode 0, 1: XREP
 If XREP is set to one together with XTF and XME (write 2A_H to CMDR), the ESCC2 repeatedly transmits the contents of the XFIFO (1 ... 32 bytes) without HDLC framing fully transparently, i.e. without FLAG, CRC or Bit Stuffing.
 The cyclic transmission is stopped with an XRES command.

STI ... Start Timer
 The internal timer is started.
Note: The timer is stopped by rewriting the TIMR register after start.

Detailed Register Description

XTF ...

Transmit Transparent Frame

- **Interrupt Mode**
After having written up to 32 bytes to the XFIFO, this command initiates the transmission of a transparent frame. An opening flag sequence is automatically added to the data by the ESCC2.
- **DMA Mode**
After having written the length of the frame to be transmitted to the XBCH, XBCL registers, this command initiates the data transfer from system memory to ESCC2 by DMA. Serial data transmission starts as soon as 32 bytes are stored in the XFIFO or the Transmit Byte Counter value is reached.

XIF ...

Transmit I-Frame (used in auto-mode only!)

Initiates the transmission of an I-frame in auto-mode. Additionally to the opening flag sequence, the address and control field of the frame is automatically added by ESCC2.

XME ...

Transmit Message End (used in interrupt-mode only!)

Indicates that the data block written last to the transmit FIFO completes the current frame. The ESCC2 can terminate the transmission operation properly by appending the CRC and the closing flag sequence to the data.

In DMA Mode, the end of the frame is determined by the Transmit Byte Count in XBCH, XBCL, thus, XME is not used in this case.

XRES ...

Transmitter Reset

XFIFO is cleared of any data and an abort sequence (seven '1's) followed by interframe time-fill is transmitted. In response to XRES an XPR interrupt is generated.

This command can be used by the CPU to abort a frame currently in transmission.

Note: The maximum time between writing to the CMDR register and the execution of the command is 2.5 clock cycles. Therefore, if the CPU operates with a very high clock rate in comparison with the ESCC2's clock, it is recommended to check the CEC bit of the STAR register before writing to the CMDR register to avoid any loss of commands.

Detailed Register Description

Receive Status Register (RSTA)

Access: read address: ch-A: 21_H
ch-B: 61_H

	7							0
RSTA	VFR	RDO	CRC	RAB	HA1	HA0	C/R	LA

Note: The contents of the RSTA register relates to the last received HDLC frame and is updated when end-of-frame is recognized at the serial receive interface. Additionally, RSTA byte is copied into RFIFO (last byte of each stored frame). Thus, after RME interrupt instead of the contents of RSTA register the RSTA byte stored in the RFIFO as the last byte of each frame should be evaluated.

VFR ...

Valid Frame

Determines whether a valid frame has been received.

- 1 ... valid
- 0 ... invalid.

An invalid frame is either

- a frame which is not an integer number of 8 bits ($n \times 8$ bits) in length (e.g. 25 bits), or
- a frame which is too short taking into account the operation mode selected via MODE (MDS1, MDS0, ADM) and the selected CRC algorithm (CCR2:C32) and the selection of receive CRC ON/OFF (CCR3:RCRC) as follows:
 - auto-/non-auto mode (16-bit address), RCRC = 0 : 4 bytes (CRC-CCITT) or 6 (CRC-32)
 - auto-/non-auto mode (16-bit address), RCRC = 1 : 3-4 bytes (CRC-CCITT) or 3-6 (CRC-32)
 - auto-/non-auto mode (8-bit address), RCRC = 0 : 3 bytes (CRC-CCITT) or 5 (CRC-32)
 - auto-/non-auto-mode (8-bit address), RCRC = 1 : 2-3 bytes (CRC-CCITT) or 2-5 (CRC-32)
 - transparent mode 1: 3 bytes (CRC-CCITT) or 5 (CRC-32)
 - transparent mode 0: 2 bytes (CRC-CCITT) or 4 (CRC-32)

Note: Shorter frames are not reported.

RDO ...

Receive Data Overflow

A data overflow has occurred during reception of the frame. Additionally, an interrupt can be generated (refer to ISR1:RDO / IMR1:RDO).

Detailed Register Description

CRC ...	<p>CRC Compare/Check</p> <p>0 ... CRC check failed; received frame contains errors. 1 ... CRC check o.k.; received frame is error-free.</p>
RAB ...	<p>Receive Message Aborted</p> <p>The received frame was aborted from the transmitting station. According to the HDLC protocol, this frame must be discarded by the receiver station.</p>
HA1 ... HA0 ...	<p>High Byte Address Compare</p> <p>Significant only if 2-byte address mode has been selected. In operating modes which provide high byte address recognition, the ESCC2 compares the high byte of a 2-byte address with the contents of two individually programmable registers (RAH1, RAH2) and the fixed values FE_H and FC_H (broadcast address). Dependent on the result of this comparison, the following bit combinations are possible:</p> <p>10 ... RAH1 has been recognized 00 ... RAH2 has been recognized 01 ... broadcast address has been recognized</p> <p><i>Note: If RAH1, RAH2 contain identical values, a match is indicated by '10'.</i></p>
C/R ...	<p>Command/Response</p> <p>Significant only if 2-byte address mode has been selected. Value of the C/R bit (bit in high address byte) in the received frame. The interpretation depends on the setting of the CRI bit in the RAH1 register. Refer also to the description of RAH1 register.</p>
LA ...	<p>Low Byte Address Compare</p> <p>Not significant in transparent and extended transparent operating modes.</p> <p>The low byte address of a 2-byte address field, or the single address byte of a 1-byte address field is compared with two registers (RAL1, RAL2).</p> <p>0 ... RAL2 has been recognized. 1 ... RAL1 has been recognized.</p> <p>According to the X.25 LAPB protocol, RAL1 is interpreted as the address of a COMMAND frame and RAL2 is interpreted as the address of a RESPONSE frame.</p>

Detailed Register Description

Mode Register (MODE)

Access: read/write address: ch-A: 22_H
ch-B: 62_H

Value after RESET: 00_H

	7							0
MODE	MDS1	MDS0	ADM	TMD	RAC	RTS	TRS	TLP

MDS1 ... MDS0 ... Mode Select

The operating mode of the HDLC controller is selected.
 00 ... auto-mode
 01 ... non auto-mode
 10 ... transparent mode
 11 ... extended transparent mode

ADM ... Address Mode

The meaning of this bit varies depending on the selected operating mode:

- auto-mode, non auto-mode
 Defines the length of the HDLC address field.
 0 ... 8-bit address field
 1 ... 16-bit address field

In transparent modes, this bit differentiates between two sub-modes:

- transparent mode
 0 ... transparent mode 0; no address recognition.
 1 ... transparent mode 1; high byte address recognition.
- extended transparent mode; without HDLC framing.
 0 ... extended transparent mode 0
 1 ... extended transparent mode 1

Note: In extended transparent modes, the RAC bit must be reset to enable fully transparent reception.

Detailed Register Description

TMD ...	Timer Mode Determines the operating mode of the timer. 0 ... external mode The timer is controlled by the CPU and can be started at any time by setting the STI bit in CMDR. 1 ... internal mode The timer is used internally by the ESCC2 for time-out and retry conditions in auto-mode (refer to the description of the TIMR register).
RAC ...	Receiver Active Switches the receiver to operational or inoperational state. 0 ... receiver inactive 1 ... receiver active In extended transparent modes this bit must be reset to enable fully transparent reception.
RTS ...	Request To Send Defines the state and control of $\overline{\text{RTS}}$ pin. 0 ... The $\overline{\text{RTS}}$ pin is controlled by the ESCC2 autonomously. $\overline{\text{RTS}}$ is activated when a frame transmission starts and deactivated when transmission is completed. 1 ... The $\overline{\text{RTS}}$ pin is controlled by the CPU. If this bit is set, the $\overline{\text{RTS}}$ pin is activated immediately and remains active till this bit is reset.
TRS ...	Timer Resolution Selects the resolution of the internal timer (factor k, see description of TIMR register): 0 ... k = 32 768 1 ... k = 512
TLP ...	Test Loop Input and output of the HDLC channel are internally connected. (transmitter channel A – receiver channel A/ transmitter channel B – receiver channel B)

Detailed Register Description

Timer Register (TIMR)

Access: read/write address: ch-A: 23_H
ch-B: 63_H

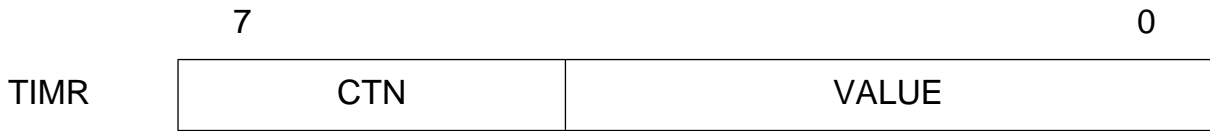

VALUE ... (5 bits) Sets the time period t_1 as follows:

$$t_1 = k \times (\text{VALUE} + 1) \times \text{TCP}$$

where

- k is the timer resolution factor which is either 32 768 or 512 clock cycles dependent on the programming of TRS bit in MODE.
- TCP is the clock period of transmit data (CCR0:MCE = '0') or master clock (CCR0:MCE = '1').

CNT ... (3 bits) Interpreted differently depending on the selected timer mode (bit TMD in MODE).

- Internal timer mode (MODE:TMD = '1') – Retry Counter (in HDLC known as N2)
CNT indicates the number of S-commands (max. 6) which are transmitted autonomously by the ESCC2 after expiration of time period t_1 , in case an I-frame is not acknowledged by the opposite station.
If CNT is set to 7, the number of S-commands is unlimited.
- External timer mode (MODE:TMD = '0')
CNT plus VALUE determine the time period t_2 after which a timer interrupt will be generated. The time period t_2 is
 $t_2 = 32 \times k \times \text{CNT} \times \text{TCP} + t_1$.
If CNT is set to 7, a timer interrupt is periodically generated after the expiration of t_1 .

Detailed Register Description

Version 3.x

TIMR Timer Register (READ/WRITE) is unchanged. However the input to the timer function can be optionally selected to be XTAL/4 in master clock mode by setting CCR0:MCE = '1' and CCR4:MCK4 = '1'.

VALUE ... (5 bits) sets the time period t_1 as follows:
 With CCR4:MCK4 = '0' and default condition, the timer value is given by the equation

$$t_1 = k \times (\text{VALUE} + 1) \times \text{TCP}$$
 where
 – k is the timer resolution factor which is either 32 768 (if MODE:TRS = '0') or 512 (if MODE:TRS = '1') clock cycles.
 – TCP is the clock period of the Timer Clock.

Non Master Clock Mode (CCR0:MCE = '0')

Timer Clock Period (TCP) = Transmit Clock Period

Master Clock Mode (CCR0:MCE = '1')

if CCR4:MCK4 = '0' (Reset state)

Timer Clock Period (TCP) = XTAL Clock Period

if CCR4:MCK4 = '1'

Timer Clock Period (TCP) = XTAL Clock Period/4

With CCR4:MCK4 = '1' in master clock mode, XTAL clock divide-by-4 is fed to the timer block. The XTAL clock feeds the baud rate generator which is used to select the transmit and received baud rate and generates the 16- \times oversampling clock. By this means, a XTAL clock of 30 MHz can be used while maintaining the core logic's clock operation limit of 10 MHz.

CNT ... (3 bits) The CNT function is unchanged.

Detailed Register Description

Transmit Byte Count Low (XBCL)

Access: write address: ch-A: 2A_H
ch-B: 6A_H



Together with XBCH (bits XBC11 ... XBC8) this register is used in DMA mode only, to program the length (1 ... 4096 bytes) of the next frame to be transmitted. In terms of the value *xbc*, programmed in XBC11 ... XBC0 (*xbc* = 0 ... 4095), the length of the block in number of bytes is:

$$\text{length} = \text{xbc} + 1.$$

This allows the ESCC2 to request the correct amount of DMA cycles after an XTF or XIF command in CMDR.

Received Byte Count High (RBCH)

Access: read address: ch-A: 2B_H
ch-B: 6B_H

Value after RESET: 000xxxxx

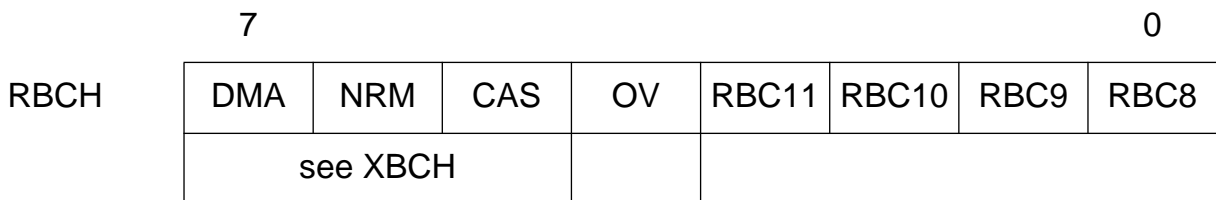

DMA, NRM, CAS ... These bits represent the read-back value programmed in XBCH
OV ... **Counter Overflow**

More than 4095 bytes received.

RBC11 ... RBC8 ... **Receive Byte Count** (most significant bits)

Together with RBCL (bits RBC7 ... RBC0) these bits indicate the length of the received frame.

Detailed Register Description

Transmit Byte Count High (XBCH)

Access: write address: ch-A: 2B_H
ch-B: 6B_H

Value after RESET: 000xxxxx

	7							0
XBCH	DMA	NRM	CAS	XC	XBC11	XBC10	XBC9	XBC8

- DMA ... DMA Mode**
 Selects the data transfer mode of ESCC2 to/from System Memory.
 0 ... Interrupt controlled data transfer (Interrupt Mode).
 1 ... DMA controlled data transfer (DMA Mode).
- NRM ... Normal Response Mode**
 Allowed in auto-mode only.
 Determines the function of the LAP Controller:
 0 ... full-duplex LAPB/LAPD operation
 1 ... half-duplex NRM operation
- CAS ... Carrier Detect Auto Start**
 When set, a 'high' on the CD pin enables the corresponding receiver and data reception is started. When not set, if not in Clock Mode 1 or 5, the CD pin can be used as a general input.
- XC ... Transmit Continuously**
 Only valid if DMA Mode is selected.
 If the XC bit is set, the ESCC2 continuously requests for transmit data ignoring the transmit byte count programmed via XBCH, XBCL. The byte count programmed via XBCH, XBCL, however, must be set to a value different from '0'.
- XBC11 ... XBC8 ... Transmit Byte Count (most significant bits)**
 Valid only if DMA Mode is selected.
 Together with XBCL (bits XBC7 ... XBC0) these bits determine the length of the frame to be transmitted.

Detailed Register Description

ODS ...

Output Driver Select

Defines the function of the transmit data pin (TxD)

0 ... TxD pin is an open drain output.

1 ... TxD pin is a push-pull output.

Note: This feature is also valid for pin RxD if it is switched to TxD function via bit CCR2:SOCl.

ITF/OIN ...

Interframe Time-Fill / One Insertion

The function of this bit depends on the selected Serial Port Configuration (bit SC1):

- Point-to-point configurations: ITF
Determines the idle (= no data to send) state of the transmit data pin TxD
- 0 ... Continuous logical '1' is output
1 ... Continuous FLAG sequences are output ('01111110'-bit patterns)

• Bus configurations: OIN
When this bit is set, a 'ONE' insertion (deletion) mechanism is activated: a '1' is inserted after seven consecutive '0's in the transmit data stream and a '1' is deleted after seven consecutive '0' in the receive data stream.

Similar to the HDLC bit stuffing mechanism (inserting a '0' after five consecutive '1's), this enables clock information to be recovered from the receive data stream by means of a DPLL even in the case of NRZ encoding, because a transition at bit cell boundary occurs at least every 7 bits. The 'One Insertion' cannot be used in conjunction with the master clock option.

Note: In bus configurations, the ITF is implicitly set to '0', i.e. continuous '1's are transmitted, and data encoding is NRZ.

CM2 ... CMO ...

Clock Mode

Selects one of 8 different clock modes:

000 clock mode 0

. .

. .

. .

111 clock mode 7

Detailed Register Description

BDF ...	<p>Baud Rate Division Factor</p> <p>0 ... The division factor of the baud rate generator is set to '1' (constant).</p> <p>1 ... The division factor is determined by BR9 ... BR0 bits in CCR2 and BRG registers.</p>
SSEL ...	<p>Clock Source Select</p> <p>Selects the clock source in clock modes 0, 2, 3, 6 and 7 (refer to table 5).</p>
TOE ...	<p>TxCLK Output Enable</p> <p>0 ... TxCLK pin is input.</p> <p>1 ... TxCLK pin is switched to output function if applicable to the selected clock mode (refer to table 5).</p>
RWX ...	<p>Read/Write Exchange</p> <p>Valid only in DMA mode. If this bit is set, the</p> <ul style="list-style-type: none"> – \overline{RD} and \overline{WR} pins are internally exchanged (Siemens/INTEL bus interface) – $\overline{R/W}$ pin is inverted in polarity (Motorola bus interface) while any \overline{DACK} input is active. This feature allows a simple interfacing to the DMA controller. <p><i>Note: The RWX bit of both channels is 'OR'ed.</i></p>
C32 ...	<p>Enable CRC-32</p> <p>0 ... CRC-CCITT is selected.</p> <p>1 ... CRC-32 is selected.</p>
DIV ...	<p>Data Inversion</p> <p>Only valid if NRZ data encoding is selected. Data is transmitted and received inverted.</p>

Detailed Register Description**RCRC ...****Receive CRC ON/OFF**

Only applicable in non-auto mode and transparent mode 0.

If this bit is set to '1', the received CRC checksum will be written to RFIFO (CRC-CCITT: 2 bytes; CRC-32: 4 bytes). The checksum, consisting of the 2 (or 4) last bytes in the received frame, is followed in the RFIFO by the status information byte (contents of register RSTA). The received CRC checksum will additionally be checked for correctness. If non-auto mode is selected, the limits for 'Valid Frame' check are modified (refer to RSTA:VFR).

XCRC ...**Transmit CRC ON/OFF**

If this bit is set to '1', the CRC checksum will not be generated internally. It has to be written as the last two or four bytes in the transmit FIFO (XFIFO). The transmitted frame will be closed automatically with a closing flag.

Note: The ESCC2 does not check whether the length of the frame, i.e. the number of bytes to be transmitted makes sense or not.

PSD ...**DPLL Phase Shift Disable**

Only applicable in the case of NRZ and NRZI encoding.

If this bit is set to '1', the Phase Shift function of the DPLL is disabled. In this case the windows for Phase Adjustment are extended.

Detailed Register Description

Time-Slot Assignment Register Transmit (TSAX)

Access: write address: ch-A: 30_H
ch-B: 70_H

Value after RESET: 00_H

Note: This register is only used in clock mode 5!

	7		0
TSAX	TSNX		XCS2 XCS1

TSNX ... Time-Slot Number Transmit

Selects one of up to 64 possible time-slots (00_H ... 3F_H) in which data is transmitted. The number of bits per time-slot can be programmed via XCCR.

XCS2 ... XCS1 ... Transmit Clock Shift, Bit 2 ... 1

Together with bit XCS0 in CCR2, transmit clock shift can be adjusted.

Time-Slot Assignment Register Receive (TSAR)

Access: write address: ch-A: 31_H
ch-B: 71_H

Value after RESET: 00_H

This register is only used in clock mode 5!

	7		0
TSAR	TSNR		RCS2 RCS1

TSNR ... Time-slot Number Receive

Defines one of up to 64 possible time-slots (00_H ... 3F_H) in which data is received. The number of bits per time-slot can be programmed via RCCR.

RCS2 ... RCS1 ... Receive Clock Shift, Bit 2 ... 1

Together with bit RCS0 in CCR2, the receive clock shift can be adjusted.

Detailed Register Description

Version Status Register (VSTR)

Access: read address: ch-A: 34_H
ch-B: 74_H

	7							0
VSTR	CD	DPLA	0	0	VN3	VN2	VN1	VN0

CD ... Carrier Detect
 This bit reflects the state of the CD pin.
 1 ... CD active
 0 ... CD inactive

DPLA ... DPLL Asynchronous
 This bit is only valid when the receive clock is supplied by the DPLL and FM0, FM1 or Manchester data encoding is selected.
 It is set when the DPLL has lost synchronization. Reception is disabled (receiver aborted) until synchronization has been regained. Additionally, transmission is interrupted, too, if the transmit clock is derived from the DPLL (same effect as the deactivation of pin $\overline{\text{CTS}}$).

VN3 ... VN0 ... Version Number of Chip
 0000 ... Version 1
 0001 ... Version 2
 0010 ... Version 3.2

Detailed Register Description

Baud Rate Generator Register (BGR)

Access: write address: ch-A: 34_H
 ch-B: 74_H



BR7 ... BR0 ... Baud Rate, bits 7 ... 0

The Baud Rate generator divisor consists of bits BR0-7 from BRG register and bits BR8-9 from the CCR2 register.
 The baud rate generator has two modes of operation giving added flexibility.

Standard Mode:

bits BR9-0 give a value N (N = 0 ... 1023) to give a XTAL clock division factor k:
 $k = (N + 1) \times 2$

Enhanced Mode: (version 3.x upwards)

This consists of a 2 stage divider. The first stage is divisor N is determined by bits BR5-BR0 (N = 0 ... 63) while the second stage divisor M is determined by bit BR9 ... BR6 (M = 0 ... 15). The first stage divides the clock by integer number up to 63, where the second stage allows further division by powers of 2 (1, 2, 4, 8, 16, 32, 64, 128, ..., 32768).

Division by 1 using M = '0' is restricted to frequencies below 10 MHz (to be characterized). The XTAL clock division factor k:
 $k = (N + 1) \times 2^M$

The Baud Rate generator is typically used to derive clocks for DTE or DCE asynchronous baud rates with 16- \times oversampling mode. **Appendix A** shows baud rates derived from typical XTAL frequencies using the two modes of the baud rate generator for ASYNC operation with 16- \times oversampling enabled.

Detailed Register Description

Receive Length Check Register (RLCR)

Access: write address: ch-A: 35H ch-B: 75H

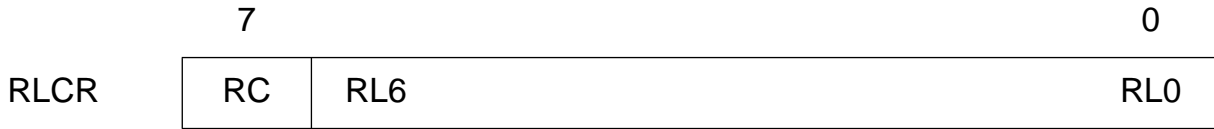

RC ... Receive Check (on/off)
 0 ... Receive Length Check feature disabled
 1 ... Receive Length Check feature enabled

RL6 ... RL0 ... Receive Length
 The maximum receive length after which data reception is suspended can be programmed here. The receive length is $(RL + 1) \times 32$ bytes, where RL is the value programmed via RL6-0.
 A frame exceeding this length is treated as if it was aborted by the opposite station (RME Interrupt, RAB bit set).
 In this case, the Receive Byte Count (RBCH, RBCL) is greater than the programmed Receive Length.

Address Mask Low (AML) (version 2 upwards)

Access: write address: ch-A: 36H ch-B: 76H

Value after RESET: 00H

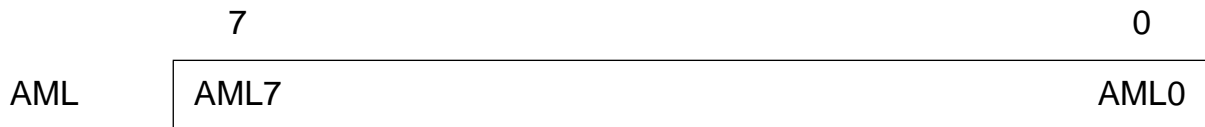

The Receive Address Low Byte (RAL1) can be masked by setting corresponding bits in this mask register to allow extended broadcast address recognition. This feature is applicable in all operating modes with address recognition. The function is disabled if all bits of this register are set to 'zero' (RESET value).

Detailed Register Description

Address Mask High (AMH) (version 2 upwards)

Access: write address: ch-A: 37_H
ch-B: 77_H

Value after RESET: 00_H



The function is similar to AML but with respect to register RAH1.

Global Interrupt Status Register (GIS)

Access: read address: ch-A: 38_H
ch-B: 78_H

Value after RESET: 00_H

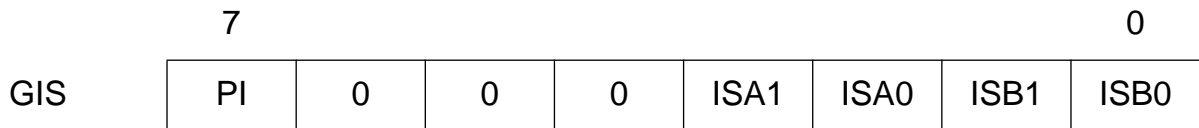

This status register points to pending

- channel assigned interrupts (ISR0, ISR1 of either channel)
- universal port interrupts (PIS).

It is accessible via both channel addresses (38_H or 78_H). As opposed to the 'real' interrupt status registers (ISR0, ISR1, PIS), its contents are not cleared after a read access. The bits in GIS are individually reset when the corresponding interrupt status register (PIS, ISR1 for channel A, ...) has been read.

Detailed Register Description

Interrupt Vector Address (IVA)

Access: write address: ch-A: 38_H
 ch-B: 78_H

Value after RESET: 00_H

	7							0
IVA	T7	TV3	TV5	TV4	T3	0	0	0

Note: Unused bits have to be set to logical '0'.

IVA is accessible via both channel addresses (38_H or 78_H).

T7 ... T3 ...

Interrupt Vector Address

These bits define the value of bits 3 to 7 of the interrupt vector which is sent out on the data bus (D0 ... D7) during the interrupt acknowledge cycle.

Detailed Register Description

Interrupt Port Configuration (IPC)

Access: read/write address: ch-A: 39_H
ch-B: 79_H

Value after RESET: 00_H

	7							0
IPC	VIS	0	0	SLA1	SLA0	CASM	IC1	IC0

Note: Unused bits have to be set to logical '0'.

IPC is accessible via both channel addresses (39_H or 79_H).

- VIS ... Masked Interrupts Visible**
 0 ... Masked interrupt status bits are not visible
 1 ... Masked interrupt status bits are visible (refer to **chapter 3.3**).
- SLA1 ... SLA0 ... Slave Address**
 Only used in Slave Cascading Mode (refer to CASM).
- CASM ... Cascading Mode**
 0 ... Slave Cascading Mode
 Pins IE0, IE1 are used as inputs. Interrupt acknowledge is accepted if an interrupt signal has been generated and the values on pins IE0 and IE1 correspond to the programmed values in SLA0, SLA1 (slave address).
 1 ... Daisy Chaining Mode
 Pin IE0 as Interrupt Enable Output and pin IE1 as Interrupt Enable Input are used for building a Daisy Chain. Interrupt acknowledge is accepted if an interrupt signal has been generated and Interrupt Enable Input IE1 is active 'high' during a subsequent INTA cycle(s). If pin INT goes active, Interrupt Enable Output IE0 is immediately set 'low'.
- IC1 ... IC0 ... Interrupt Port Configuration**
 These bits define the function of the interrupt output stage (pin INT):

IOC1	IOC0	Function
X	0	Open Drain output
0	1	Push/Pull output, active 'low'
1	1	Push/Pull output, active 'high'

Detailed Register Description

Interrupt Status Register 0 (ISR0)

Access: read address: ch-A: 3A_H
ch-B: 7A_H

Value after RESET: 00_H

	7							0
ISR0	RME	RFS	RSC	PCE	PLLA	CDSC	RFO	RPF

All bits are reset when ISR0 is read. Additionally, RME and RPF are reset when the corresponding interrupt vector is output.

Note: If bit IPC:VIS is set to '1', interrupt statuses in ISR0 may be flagged although they are masked via register IMR0. However, these masked interrupt statuses neither generate an interrupt vector or a signal on INT, nor are visible in register GIS.

RME ... Receive Message End

One complete message of length less than 32 bytes, or the last part of a frame at most 32 bytes long including the status byte is stored in the receive FIFO.

The complete message length can be determined reading the RBCH, RBCL registers, the number of bytes currently stored in RFIFO is given by RBC4 ... 0. Additional information is available in the RSTA byte, stored in the RFIFO as the last byte of each frame.

RFS ... Receive Frame Start

This is an early receiver interrupt activated after the start of a valid frame has been detected, i.e. after an address match (in operation modes providing address recognition), or after the opening flag (transparent mode 0) is detected, delayed by two bytes. After an RFS interrupt, the contents of

- RHCR
- RAL1
- RSTA-bits 3 ... 0

are valid and can be read by the CPU.

RSC ... Receive Status Change (significant in auto-mode only)

A status change (receiver ready/receiver not ready) of the remote station has been detected by receiving a RR/RNR supervisory frame. The actual status can be read from the STAR register (RRNR bit).

Detailed Register Description

PCE ...	Protocol Error (significant in auto-mode only) The ESCC2 has detected a protocol error, i.e. it has received <ul style="list-style-type: none">– an S- or I-frame with incorrect N(R)– an S-frame containing an I-field.
PLLA ...	DPLL Asynchronous This bit is only valid when the receive clock is supplied by the DPLL and FM0, FM1 or Manchester data encoding is selected. It is set when the DPLL has lost synchronization. Reception is disabled (receiver aborted) until synchronization has been regained. Additionally, transmission is also interrupted if the transmit clock is derived from the DPLL.
CDSC ...	Carrier Detect Status Change Indicates that a state transition has occurred on CD. The actual state can be read from the VSTR register.
RFO ...	Receive Frame Overflow At least one complete frame was lost because no storage space was available in the RFIFO. This interrupt can be used for statistical purposes and indicates that the CPU does not respond quickly enough to an RPF or RME interrupt.
RPF ...	Receive Pool Full 32 bytes of a frame have arrived in the receive FIFO. The frame is not yet completely received. <i>Note: This interrupt is only generated in Interrupt Mode.</i>

Detailed Register Description

Interrupt Status Register 1 (ISR1)

Access: read address: ch-A: 3B_H
ch-B: 7B_H

Value after RESET: 00_H

	7						0	
ISR1	EOP	OLP/ RDO	AOLP/ ALLS	XDU/ EXE	TIN	CSC	XMR	XPR

All bits are reset when ISR1 is read. Additionally, XPR is reset when the corresponding interrupt vector is output.

Note: If bit IPC:VIS is set to '1', interrupt statuses in ISR1 may be flagged although they are masked via register IMR1. However, these masked interrupt statuses neither generate an interrupt vector or a signal on INT, nor are visible in register GIS.

EOP ... End of Poll Sequence Detected

Only valid if SDLC Loop mode is selected.
It is set if an EOP sequence has been received.

OLP/RDO ... On Loop

Only valid if SDLC Loop mode is selected.
It is set in response to a Go On Loop command, but not before an EOP sequence has been received. It is also set when returning from the Active On Loop state. All incoming bits on RxD are reflected onto TxD with one bit delay.

Receive Data Overflow

Not applicable in SDLC Loop mode
This interrupt status is an early warning that data has been lost. It is classified as group 7 or group 8 interrupt. Even when this interrupt status is generated, the frame continues to be received when space in the RFIFO is available again.

Note: Whereas the bit RSTA:RDO in the frame status byte indicates whether an overflow occurred when receiving the frame currently accessed in the RFIFO, the ISR1:RDO interrupt status is generated as soon as an overflow occurs and does not necessarily pertain to the frame currently accessed by the processor or the DMA controller.

Detailed Register Description

AOLP/ALLS ...**Active On Loop**

Only valid if SDLC Loop mode is selected.

It is set in response to a Go Active On Loop command, but not before an EOP sequence has been received. TxD is disconnected from RxD and transmission of flags or data is started.

All Sent

Only valid if SDLC loop mode is not selected.

This bit is set

- if the last bit of the current frame is completely sent out on TxD and XFIFO is empty (non-auto mode, transparent modes),
- if an I-frame is completely sent out on TxD and a positive acknowledgement has been received (auto mode),
- In auto-mode, if an I-frame has been sent and a timer interrupt (TIN) is generated because the internal timer expires before an acknowledgement is received: in this case ALLS is generated one clock period after (TIN).

XDU/EXE ...**Transmit Data Underrun/Extended Transmission End**

Transmitted frame was terminated with an abort sequence because no data was available for transmission in XFIFO and no XME was issued (interrupt mode) or DMA request was not satisfied in time (DMA mode).

Note: Transmitter and XFIFO are reset and deactivated if this condition occurs. They are reactivated not before this interrupt status register has been read. Thus, XDU should not be masked via register IMR1.

In extended transparent mode, this bit indicates the transmission-end condition (EXE).

TIN ...**Timer Interrupt**

The internal timer and repeat counter has expired (see also description of TIMR register).

Detailed Register Description

CSC ...

Clear To Send Status Change

Indicates that a state transition has occurred on $\overline{\text{CTS}}$. The actual state can be read from STAR register (CTS bit).

XMR ...

Transmit Message Repeat

The transmission of the last frame has to be repeated because

- the ESCC2 has received a negative acknowledgement to an I-frame in auto-mode, or
- a collision has occurred after at least one FIFO block of data has been completely transmitted, and thus an automatic re-transmission cannot be attempted, or
- $\overline{\text{CTS}}$ (transmission enable) has been withdrawn after at least one FIFO block of data has been transmitted and the frame has not been completed.

Note: For easier recovery in the case of a collision, XFIFO should not contain data of more than one frame.

The use of ALLS interrupt is therefore recommended.

XPR ...

Transmit Pool Ready

A data block of up to 32 bytes can be written to the transmit FIFO. XPR enables the fastest access to XFIFO. It has to be used for transmission of long frames, back-to-back frames or frames with shared flags. However, starting transmission of a **new** frame should be initiated after ALLS interrupt instead of XPR

- in auto mode
- in bus configurations
- if contents of XFIFO have to be unique, e.g. for automatic repetition of the last frame in case of bus collisions or $\overline{\text{CTS}}$ control (see also XMR interrupt).

Note: It is not possible to send transparent, or I-frames when a XMR or XDU interrupt remains unacknowledged.

Detailed Register Description

Interrupt Mask Register 0, 1 (IMR0,1)

Access: write address: ch-A: 3A_H (IMR0), 3B_H (IMR1)
 ch-B: 7A_H (IMR0), 7B_H (IMR1)

Value after RESET: FF_H, FF_H

	7							0
IMR0	RME	RFS	RSC	PCE	PLLA	CDSC	RFO	RPF
MR1	EOP	OLP/ RDO	AOLP/ ALLS	XDU/ EXE	TIN	CSC	XMR	XPR

Each interrupt source can generate an interrupt signal at port INT (function of the output stage is defined via register IPC). Each source in IMR0 or IMR1 sets the mask active for the interrupt status in ISR0 or ISR1. Masked interrupt statuses neither generate an interrupt vector or a signal on INT, nor are they visible in register GIS. Moreover, they will

- not be displayed in the Interrupt Status Register if bit IPC:VIS is set to ‘0’
- be displayed in the Interrupt Status Register if bit IPC:VIS is set to ‘1’.

*Note: After RESET, all interrupts are **disabled**.*

Port Value Register (PVR)

Access: read/write address: ch-A: 3C_H
 ch-B: 7C_H

	7							0
PVR	PVR7						PVR0	

Each of the above bits is assigned to the Universal Port pin (P0 ... P7) with the same number.

Read Access

PVR shows the value of all pins (input and output). Input values can be separated via software by ‘AND’-ing PCR and PVR.

Write Access

PVR accepts values for all output pins (defined via PCR). Values written to input pin locations are ignored.

Detailed Register Description

Port Interrupt Mask Register (PIM)

Access: write address: ch-A: 3D_H
ch-B: 7D_H

Value after RESET: FF_H



Each of the above bits is assigned to the Universal Port pin (P0 ... P7) and to the bits of register PIS with the same number.

0 ... Interrupt source is enabled.

1 ... Interrupt source is disabled.

A '1' in a bit position of PIM sets the mask active for the interrupt status in PIS. Mask interrupt statuses neither generate an interrupt vector or a signal on INT, nor are they visible in register GIS.

Moreover, they will

- not be displayed in the Interrupt Status Register if bit IPC:VIS is set to '0',
- be displayed in the Interrupt Status Register if bit IPC:VIS is set to '1'.

Refer to description of register PIS.

*Note: After RESET, all interrupt sources are **disabled**.*

Port Configuration Register (PCR)

Access: read/write address: ch-A: 3E_H
ch-B: 7E_H

Value after RESET: FF_H



Each of the above bits is assigned to the Universal Port pin (P0 ... P7) with the same number. If bit PCR_n (n = 0 ... 7) is set to

0 ... pin P_n is defined as output.

1 ... pin P_n is defined as input.

*Note: After RESET, all pins of the Universal Port are defined as **inputs**.*

Detailed Register Description

Channel Configuration Register 4 (CCR4)

(version 2 upwards, otherwise unused)

Access: read/write address: ch-A: 3F_H
 ch-B: 7F_H

Value after RESET: 00_H

	7						0
CCR4	MCK4	EBRG	TST1	ICD	0	0	RFT1 RFT0

Note: Unused bits have to be set to '0'.

- MCK4 ...** **Master Clock divide-by-4** (V3 upwards, otherwise unused)

This bit is valid when master clock option is selected by setting CCR0:MCE = 1.

 - 0 ... (default) XTAL 1-2 clock feeds the core logic and timer blocks. This causes the XTAL frequency to be restricted to 10 MHz, thus limiting the highest baud rate to about 600 Kbit/s.
 - 1 ... XTAL1-2 clock divide-by-4 feeds the core logic and timer blocks. This allows the device to function with XTAL frequency up to 30 MHz. The baud rate generator is fed directly from the XTAL and can thus be used to provide clocks for baud rates in excess of 2 MBaud in Asynch oversampling mode. It also allows the timer block to operate at the highest resolution.

- EBRG ...** **Enhanced Baud Rate Generator Mode** (V3 upwards, otherwise unused)

 - 0 ... (default) selects standard baud rate generator operation. See description of BRG register.
 - 1 ... selects enhanced baud rate generator. See description of BRG register.

- TST1 ...** **Test Pin** (V3 upwards, otherwise unused)

Write '0' for normal operation.

- ICD ...** **Invert Polarity of Carrier Detect Signal** (V3 upwards)

 - 0 ... (default) selects the current polarity for Carrier Detect CD (Active HIGH)
 - 1 ... selects the invert polarity to be more consistent with other equipment, Carrier Detect \overline{CD} (Active LOW).
 As CD is a multifunctional pin, the ICD bit may only be set if CD functionality is being used.

Detailed Register Description

RFT, RFT0 ...

RFIFO Threshold Level

The size of the accessible part of RFIFO can be determined by programming these bits. The number of valid bytes after an RPF interrupt is given in the following table:

RFT1	RFT0	Size of accessible Part of RFIFO
0	0	32 bytes (RESET value)
0	1	16 bytes
1	0	4 bytes
1	1	2 bytes

The value of RFT1,0 can be changed dynamically

- if reception is not running (recommended: receiver is disabled by setting MODE:RAC to '0'), or
- after RME interrupt has been generated, but before the command CMDR:RMC is issued (DMA controlled data transfer), or
- after the current data block has been read, but before the command CMDR:RMC is issued (interrupt controlled data transfer). See Note.

*Note: It is seen that changing the value of RFT1, 0 is possible even **during** the reception of one frame. The total length of the received frame can be always read directly in RBCL, RBCH after an RPF interrupt, except when the threshold is **increased** during reception of that frame. The real length can then be inferred by noting which bit positions in RBCL are reset by an RMC command (see table below):*

RFT1	RFT0	Bit positions in RBCL reset by a CMDR:RMC command
0	0	RBC4 ... 0
0	1	RBC3 ... 0
1	0	RBC1,0
1	1	RBC0

Detailed Register Description

10.2 Status/Control Registers in ASYNC Mode

10.2.1 Register Addresses

Address (A0 ... A6)		Register		Meaning	Refer to Page
Channel		Read	Write		
A	B				
00	40	RFIFO	XFIFO	Receive/Transmit FIFO	161/163
.	.				
.	.				
1F	5F				
20	60	STAR	CMDR	Status Register/Command Register	164/166
21	61	–	–	–	–
22	62	MODE		Mode Register	168
23	63	TIMR		Timer Register	170
24	64	XON		XON Character	172
25	65	XOFF		XOFF Character	172
26	66	TCR		Termination Character Register	173
27	67	DAFO		Data Format	173
28	68	RFC		RFIFO Control Register	175
29	69	–	–	–	–
2A	6A	RBCL	XBCL	Receive Byte Count Low/Transmit Byte Count Low	177/177
2B	6B	RBCH	XBCH	Receive/Transmit Byte Count High	178/179
2C	6C	CCR0		Channel Configuration Register 0	180
2D	6D	CCR1		Channel Configuration Register 1	181
2E	6E	CCR2		Channel Configuration Register 2	182
2F	6F	CCR3		Channel Configuration Register 3	184

Detailed Register Description

10.2.1 Register Addresses (cont'd)

Address (A0 ... A6)		Register		Meaning	Refer to Page
Channel		Read	Write		
A	B				
30	70	–	TSAX	Time-slot Assignment Register Transmit	184
31	71	–	TSAR	Time-slot Assignment Register Receive	185
32	72	–	XCCR	Transmit Channel Capacity Register	185
33	73	–	RCCR	Receive Channel Capacity Register	186
34	74	VSTR	BGR	Version Status/Baud Rate Generator Register	186/187
35	75	–	TIC	Transmit Immediate Character	188
36	76	–	MXN	Mask XON Character	189
37	77	–	MXF	Mask XOFF Character	189
38	78	GIS ¹⁾	IVA ¹⁾	Global Interrupt Status/Interrupt Vector Address	190/190
39	79	IPC ¹⁾		Interrupt Port Configuration	191
3A	7A	ISR0	IMR0	Interrupt Status 0/Interrupt Mask 0	192/195
3B	7B	ISR1	IMR1	Interrupt Status 1/Interrupt Mask 1	193/195
3C	7C	PVR		Port Value Register	195
3D	7D	PIS ¹⁾	PIM ¹⁾	Port Interrupt Status/Port Interrupt Mask	196/197
3E	7E	PCR ¹⁾		Port Configuration Register	197
3F	7F	CCR4		Channel Configuration Register 4	198

¹⁾ Both channel assigned addresses enable access to the same register(s).

*Note: Read access to unused register addresses: value should be ignored,
Write access to unused register addresses: should be avoided, or set to '00_H'.*

Detailed Register Description

10.2.2 Register Definitions

Receive FIFO (RFIFO)

Access: read address: ch-A: 00 ... 1F_H
ch-B: 40 ... 5F_H

Received data stored in RFIFO (LSB is received first) can be organized in one of two selectable ways (refer to **figure 51**):

- pure data up to a character length of 8 bits (incl. optional parity)
- additionally, one status byte per character with information about parity (if enabled), parity error and framing error.

Reading data from RFIFO can be done in 8-bit (byte) or 16-bit (word) access depending on the selected bus interface mode. The LSB is received first from the serial interface.

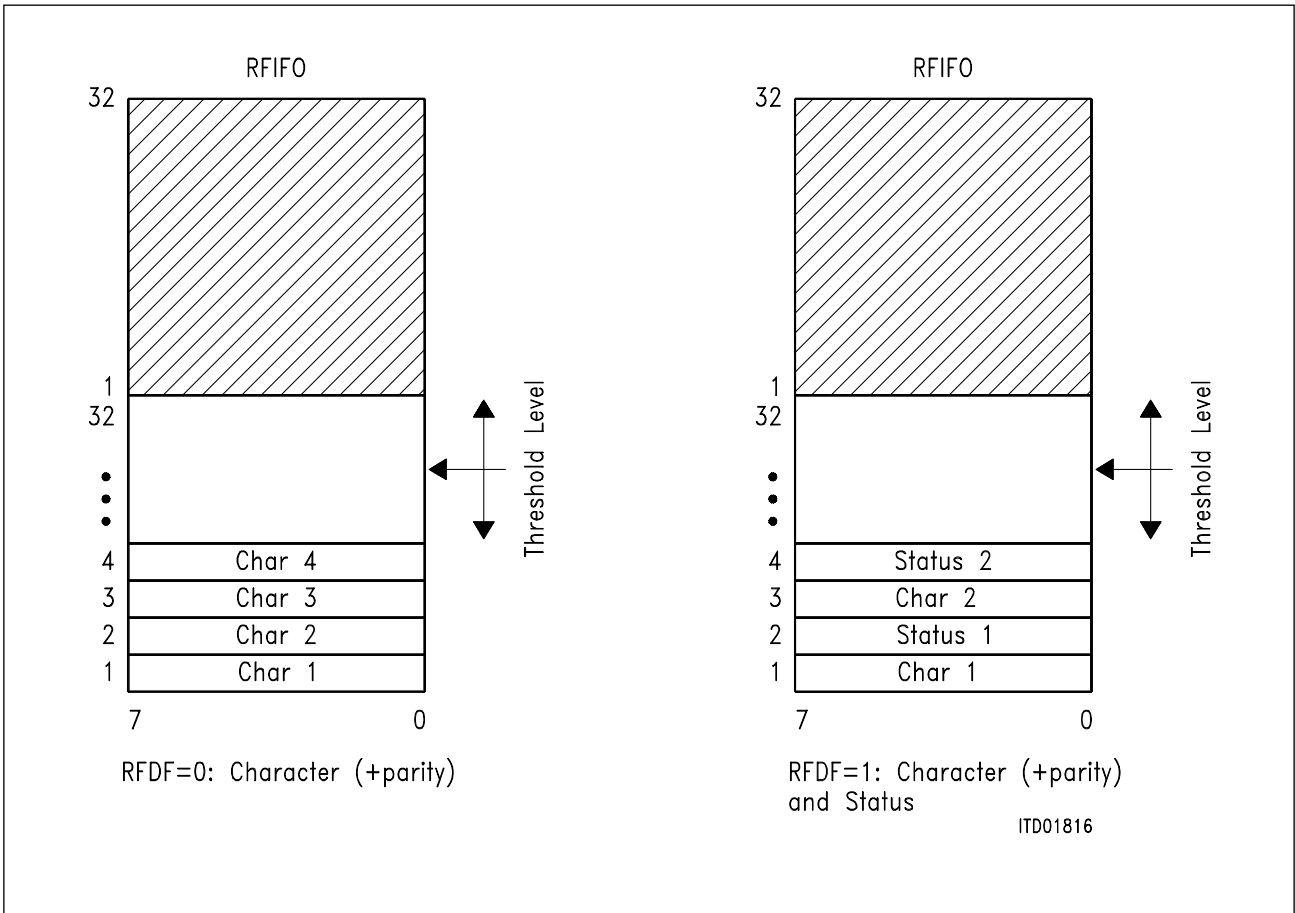

Figure 51
Organization of RFIFO

Detailed Register Description**Interrupt Controlled Data Transfer (interrupt mode)**

Selected if DMA bit in XBCH is reset.

Up to 32 bytes/16 words of received data can be read from the RFIFO following a RPF or a TCD interrupt depending on the selected RFIFO mode (refer to RFC register):

RPF interrupt: A fixed number of bytes/words (programmed threshold level RPTH0, 1) has to be read by the CPU.

TCD interrupt: Termination character detected. The received data stream is monitored for 'termination character' (programmable via register TCR). The number of valid **bytes** in RFIFO is determined by reading the RBCL register.

If necessary, the CPU can access the RFIFO by issuing RFIFO Read command (CMDR.RFRD) before threshold level or the termination condition is reached. The number of valid **bytes** is determined by reading the RBCL register. Additional information: STAR:RFNE: RFIFO Not Empty.

DMA Controlled Data Transfer (DMA mode)

Selected if DMA bit in XBCH is set.

If the RFIFO contains the number of bytes/words defined via the threshold level, the ESCC2 autonomously requests a DMA block data transfer by DMA by activating the DRRn line until the last valid data is read (the DDRn line remains active up to the beginning of the last read cycle).

This forces the DMA controller to continuously perform bus cycles till all data is transferred from the ESCC2 to the system memory (level triggered transfer mode of DMA controller). If the end condition (TCD) is reached, the same procedure as above is performed. DRRn is activated until the termination character is transferred. A TCD interrupt is issued after the last data has been transferred. Generation of further DMA requests is blocked until TCD interrupt has been acknowledged by issuing an RMC command. The valid byte count of the last block can be determined by reading the RBCL register following the TCD interrupt.

Note: Addresses within the 32-byte address space of the FIFO's point all to the same byte/word, i.e. current data can be accessed with any address within the valid scope.

Detailed Register Description

Status Register (STAR)

Access: read address: ch-A: 20_H
 ch-B: 60_H

Value after RESET: 40_H

	7							0
STAR	XDOV	XFW	RFNE	FCS	TEC	CEC	CTS	0

XDOV ... **Transmit Data Overflow**
 More than 32 bytes have been written to the XFIFO.
 This bit is reset by:

- a transmitter reset command XRES
- or when all bytes in the accessible half of the XFIFO have been moved into the inaccessible half.

XFW ... **Transmit FIFO Write Enable**
 Data can be written to the XFIFO.
Note: In extended transparent mode for XFIFO write access control, the XPR interrupt should be used instead of XFW bit.

RFNE ... **RFIFO Not Empty**
 This bit is set if the accessible part of RFIFO holds at least one valid byte.

FCS ... **Flow Control Status**
 If in-band flow control is enabled via bit MODE.FLON, this status bit indicates the current state of the transmitter:

- 0 ... The transmitter is in XON state, i.e. transmission is enabled or running.
- 1 ... The transmitter is in XOFF state, i.e. transmission is stopped and disabled until an XON character is detected by the receiver.

Detailed Register Description**TEC ...****TIC Executing**

This status bit indicates that transmission instruction of currently programmed TIC (Transmit Immediate Character) is accepted but not completely executed. Further access to register TIC is only allowed after STAR:TEC has been reset by the ESCC2.

Note: Status flag TEC is set immediately with the write access to register TIC. It remains active until the transmitter of ESCC2 is able to start transmission of currently programmed TIC. Best case: TEC remains set for at most 2.5 clock periods (transmit clock or master clock, depending of the selected mode) if transmission of the programmed TIC character can be started immediately. The function of register TIC and status flag TEC is independent of whether flow control is enabled or not.

CEC ...**Command Executing**

0 ... no command is currently being executed, the CMDR register can be written to.

1 ... a command (written previously to CMDR) is currently being executed, no further command can be temporarily written into CMDR register.

Note: CEC will be active at most 2.5 transmit clock periods. If the ESCC2 is in power-down mode CEC will stay active.

CTS ...**Clear To Send State**

This bit indicates the state of the $\overline{\text{CTS}}$ pin.

0 ... $\overline{\text{CTS}}$ is inactive ('high')

1 ... $\overline{\text{CTS}}$ is active ('low').

Detailed Register Description

Command Register (CMDR)

Access: write address: ch-A: 20_H
ch-B: 60_H

Value after RESET: 00_H

	7							0
CMDR	RMC	RRES	RFRD	STI	XF	0	0	XRES

Note: Unused bits have to be set to logical '0'.

RMC ... **Receive Message Complete**

Confirmation from CPU to ESCC2 that the current frame or data block has been fetched following an RPF or RME interrupt, thus the occupied space in the RFIFO can be released.

Note: In DMA Mode, this command has to be issued after an TCD interrupt in order to enable the generation of further receiver DMA requests.

RRES ... **Receiver Reset**

All data in RFIFO and ASYNC receiver is deleted.

RFRD ... **Receive FIFO Read Enable**

The CPU can have access to RFIFO by issuing the RFRD command before threshold level or the end condition (TCD) are fulfilled. After issuing the RFRD command the CPU has to wait for TCD interrupt, before reading RBC and RFIFO. The number of valid **bytes** is determined by reading the RBCL register. Additionally, a TCD interrupt is generated if enabled.

STI ... **Start Timer**

The internal timer is started.

Note: The timer is stopped by rewriting the TIMR register after start.

Detailed Register Description**XF ...****Transmit Frame**

- **Interrupt Mode**
After having written up to 32 bytes/16 words to the XFIFO, this command initiates the transmission of data.
- **DMA Mode**
After having written the amount of data to be transmitted to the XBCH, XBCL registers, this command initiates the data transfer from system memory to ESCC2 by DMA. Serial data transmission starts as soon as 32 bytes/16 words are stored in the XFIFO or the Transmit Byte Counter value is reached.

XRES ...**Transmitter Reset**

XFIFO is cleared of any data and IDLE (logical '1's) is transmitted. This command can be used by the CPU to abort current data transmission. In response to XRES an XPR interrupt is generated.

Note: The maximum time between writing to the CMDR register and the execution of the command is 2.5 clock cycles. Therefore, if the CPU operates with a very high clock rate in comparison with the ESCC's clock, it is recommended to check the CEC bit of the STAR register before writing to the CMDR register to avoid any loss of commands.

Detailed Register Description

Mode Register (MODE)

Access: read/write address: ch-A: 22_H
 ch-B: 62_H

Value after RESET: 00_H

	7						0	
MODE	0	FRTS	FCTS	FLON	RAC	RTS	TRIS	TLP

Note: Unused bits have to be set to logical '0'.

FRTS ...

Flow Control Using RTS (V3.x, otherwise unused)

This bit is used in combination with the RTS bit as follows:

FRTS	RTS	
0	0	The $\overline{\text{RTS}}$ pin is controlled by the device autonomously and is activated ($\overline{\text{RTS}} = \text{'LOW'}$) when data is loaded in the XFIFO (default state)
1	0	RTS pin is controlled by the device autonomously for bidirectional flow control and is forced active when shadow part of RFIFO is empty and forced inactive ($\overline{\text{RTS}} = \text{'HIGH'}$) when the RFIFO has reached a threshold (see chapter 6.4.3).
0	1	By setting this combination, the software can force the $\overline{\text{RTS}}$ pin to active state ('LOW').
1	1	By setting this combination, the software can force the $\overline{\text{RTS}}$ pin to inactive state ('HIGH').

FCTS ...

Flow Control Using CTS (V3.x, otherwise unused)

- 0 ... (default) the transmitter is stopped if $\overline{\text{CTS}}$ signal is 'HIGH'. See **chapter 6.4.3**.
- 1 ... the transmitter is active continuously and disregards the condition of $\overline{\text{CTS}}$ signal. If MODE.FLON=1 then flow control is provided by using XON, XOFF characters.

Detailed Register Description

FLON ...**Flow Control ON**

The in-band flow control is activated via this bit:

- 0 ... No further action is automatically taken by the ESCC2. However, recognition of an XON or an XOFF character (defined via registers XON and XOFF) causes always a corresponding maskable interrupt status to be generated (refer to register ISR1).
- 1 ... The reception of an XOFF character (defined via register XOFF) automatically turns off the transmitter after the currently transmitted character (if any) has been completely shifted out (XOFF state). The reception of an XON character (defined via register XON) automatically makes the transmitter resume transmitting (XON state).

RAC ...**Receiver Active**

Switches the receiver to operational or inoperational state.

- 0 ... receiver inactive
- 1 ... receiver active

RTS ...**Request To Send**

Defines the state and control of $\overline{\text{RTS}}$ pin.

- 0 ... The $\overline{\text{RTS}}$ pin is controlled by the ESCC2 autonomously. $\overline{\text{RTS}}$ is activated when data transmission starts and deactivated when transmission is completed.
- 1 ... The $\overline{\text{RTS}}$ pin is controlled by the CPU. If this bit is set, the $\overline{\text{RTS}}$ pin is activated immediately and remains active till this bit is reset.

TRS ...**Timer Resolution**

Selects the resolution of the internal timer (factor k, see description of TIMR register):

- 0 ... k = 32 768
- 1 ... k = 512

TLP ...**Test Loop**

Input and output of the ASYNC channels are internally connected. (transmitter channel A – receiver channel A/
transmitter channel B – receiver channel B).

Detailed Register Description

Timer Register (TIMR)

Access: read/write

address: ch-A: 23_H

ch-B: 63_H



VALUE ...

(5 bits) Sets the time period t_1 as follows:

$$t_1 = k \times (\text{VALUE} + 1) \times \text{TCP}$$

where

- k is the timer resolution factor which is either 32 768 or 512 clock cycles dependent on the programming of TRS bit in MODE.
- TCP is the clock period of transmit data (CCR0:MCE = '0') or master clock (CCR0:MCE = '1').

CNT ...

(3 bits) CNT plus VALUE determine the time period t_2 after which a timer interrupt will be generated. The time period t_2 is

$$t_2 = 32 \times k \times \text{CNT} \times \text{TCP} + t_1.$$

If CNT is set to 7, a timer interrupt is periodically generated after the expiration of t_1 .

Detailed Register Description

Version 3.x:

TIMR Timer Register (READ/WRITE) is unchanged. However the input to the Timer function can be optionally selected to be XTAL/4 in Master clock mode by setting CCR0:MCE = '1' and CCR4:MCK4 = '1'.

VALUE ... (5 bits) sets the time period t_1 as follows:
 With CCR4:MCK4 = '0' and default condition, the timer value is given by the equation

$$t_1 = k \times (\text{VALUE} + 1) \times \text{TCP}$$
 where
 – k is the timer resolution factor which is either 32 768 (if MODE:TRS = '0') or 512 (if MODE:TRS = '1') clock cycles.
 – TCP is the clock period of the Timer Clock.

Non Master Clock Mode (CCR0:MCE = '0')

Timer Clock Period (TCP) = Transmit Clock Period

Master Clock Mode (CCR0:MCE = '1')

if CCR4:MCK4 = '0' (Reset state)

Timer Clock Period (TCP) = XTAL Clock Period

if CCR4:MCK4 = '1'

Timer Clock Period (TCP) = XTAL Clock Period/4

With CCR4:MCK4 = '1' in master clock mode, XTAL clock divide-by-4 is fed to the timer block. The XTAL clock feeds the baud rate generator which is used to select the transmit and received baud rate and generates the 16- \times oversampling clock. By this means, a XTAL clock of 30 MHz can be used while maintaining the Core logic's clock operation limit of 10 MHz.

CNT ... (3 bits) The CNT function is unchanged.

Detailed Register Description

STOP ...	<p>Stop Bit</p> <p>This bit defines the number of stop bits generated by the transmitter:</p> <p>0 ... 1 stop bit 1 ... 2 stop bits.</p>
PAR1, PAR0 ...	<p>Parity Format</p> <p>If parity check/generation is enabled by setting PARE, these bits define the parity type:</p> <p>00 ... SPACE ('0') 01 ... odd parity 10 ... even parity 11 ... MARK ('1')</p> <p>The received parity bit is stored in RFIFO</p> <ul style="list-style-type: none"> – as leading bit immediately preceding the character if character length is 5 to 7 bits and RFC.DPS is set to '0', and as LSB of the status byte pertaining to the character if the corresponding RFIFO data format is enabled, – as LSB of the status byte pertaining to the character if character length is 8 bits and the corresponding RFIFO data format is enabled. <p>Parity error is indicated in the MSB of the status byte pertaining to the character, if enabled. Additionally, a parity error interrupt can be generated.</p>
PARE ...	<p>Parity Enable</p> <p>0 ... parity check/generation disabled 1 ... parity check/generation enabled.</p>
CHL1 ... CHL0 ...	<p>Character Length</p> <p>These bits define the length of received and transmitted characters, excluding optional parity:</p> <p>00 ... 8 bit 01 ... 7 bit 10 ... 6 bit 11 ... 5 bit.</p>

Detailed Register Description

RFDF = '0'	RFDF = '1'												
<ul style="list-style-type: none"> character 5 ... 8 bit or <ul style="list-style-type: none"> character 5 ... 7(8)¹ bit + parity ¹⁾ Parity bit is lost.	<ul style="list-style-type: none"> character 5 ... 8 bit + status or <ul style="list-style-type: none"> character 5 ... 7(8)¹ bit + parity + status ¹⁾ Parity bit is in status byte.												
<div style="text-align: center;"> 7 4 0 </div> Data Byte: <table border="1" style="margin-left: 20px;"> <tr> <td style="width: 20px; height: 20px;"></td> <td style="width: 20px; height: 20px;"></td> <td style="width: 20px; height: 20px; text-align: center;">(P)</td> <td style="width: 40px; height: 20px; text-align: center;">Char</td> </tr> </table>			(P)	Char	<div style="text-align: center;"> 7 4 0 </div> Data Byte: <table border="1" style="margin-left: 20px;"> <tr> <td style="width: 20px; height: 20px;"></td> <td style="width: 20px; height: 20px;"></td> <td style="width: 20px; height: 20px; text-align: center;">(P)</td> <td style="width: 40px; height: 20px; text-align: center;">Char</td> </tr> </table> <div style="text-align: center;"> 7 6 0 </div> Data Byte: <table border="1" style="margin-left: 20px;"> <tr> <td style="width: 20px; height: 20px; text-align: center;">PE</td> <td style="width: 20px; height: 20px; text-align: center;">FE</td> <td style="width: 40px; height: 20px;"></td> <td style="width: 20px; height: 20px; text-align: center;">P</td> </tr> </table>			(P)	Char	PE	FE		P
		(P)	Char										
		(P)	Char										
PE	FE		P										
FE: framing error PE: parity error P: parity bit (P): can be disabled via bit DPS													

RFTH1, RFTH0 ...

RFIFO Threshold Level

These bits define the level up to which RFIFO is filled with valid data:

RFTH1, 0	Threshold Level (bytes)	
	RFDR = '0'	RFDF = '1'
00	1 (1d)	2 (1d + 1s)
01	4 (4d)	4 (2d + 2s)
10	16 (16d)	16 (8d + 8s)
11	32 (32d)	32 (16d + 16s)

d: data byte

s: status byte

If the threshold level is reached, the RPF interrupt is generated if enabled. After RPF is generated, the contents of RFIFO (RFTH bytes) can be read by the CPU. To indicate that this RFIFO pool can be released, an RMC command has to be issued.

TCDE ...

Termination Character Detection Enable

When this bit is set, the received data stream is monitored for 'termination character' (TCR register). When such a character occurs, the TCD interrupt is generated if enabled via mask register IMR0. The number of **bytes** to be read from RFIFO is determined by the value of RBCL.

Detailed Register Description

Received Byte Count High (RBCH)

Access: read address: ch-A: 2B_H
ch-B: 6B_H

Value after RESET: 000xxxxx

	7					0
RBCH	DMA	0	CAS	0	RBC11	RBC8
	see XBCH					

DMA, CAS ... These bits represent the read-back value programmed in XBCH

RBC11 ... RBC8 ... **Receive Byte Count** (most significant bits)

No function in ASYNC mode.

Detailed Register Description

Transmit Byte Count High (XBCH)

Access: write address: ch-A: 2B_H
ch-B: 6B_H

Value after RESET: 000xxxxx

	7						0
XBCH	DMA	0	CAS	XC	XBC11		XBC8

Note: Unused bits have to be set to logical '0'.

- DMA ...** **DMA Mode**

Selects the data transfer mode of ESCC2 to/from System Memory.

0 ... Interrupt controlled data transfer (Interrupt Mode).

1 ... DMA controlled data transfer (DMA Mode).
- CAS ...** **Carrier Detect Auto Start**

When set, a high on the CD pin enables the corresponding receiver and data reception is started. When not set, if not in Clock Mode 1 or 5, the CD pin can be used as a general input.
- XC ...** **Transmit Continuously**

Only valid if DMA Mode is selected.

If the XC bit is set, the ESCC2 continuously requests for transmit data ignoring the transmit byte count programmed via XBCH, XBCL. The byte count programmed via XBCH, XBXL, however, must be set to a value different from '0'.
- XBC11 ... XBC8 ...** **Transmit Byte Count** (most significant bits)

Valid only if DMA Mode is selected.

Together with XBCL (bits XBC7 ... XBC0), determine the number of characters to be transmitted.

Detailed Register Description

Channel Configuration Register 0 (CCR0)

Access: read/write address: ch-A: 2C_H
 ch-B: 6C_H

Value after RESET: 00_H

	7							0
CCR0	PU	MCE	0	SC2	SC1	SC0	SM1	SM0

Note: Unused bits have to be set to logical '0'.

PU ... Switches between Power-up and Power-down Mode

0 ... power-down (standby)
 1 ... power-up (active).

MCE Master Clock Enable

If this bit is set to '1', the clock provided via pin XTAL1 works as master clock to allow full functionality of the microprocessor interface (access to all status and control registers, DMA and interrupt support) independent of the receive and the transmit clocks. The internal oscillator in conjunction with a crystal on XTAL1–2 can be used, too. The master clock option is not applicable in clock mode 5. Refer to **table 5** for more details.

Note: The internal timers run with the master clock.

SC2 ... SC0... Serial Port Configuration

000 ... NRZ data encoding
 001 ... (not recommended)
 010 ... NRZI data encoding
 011 ... (not recommended)
 100 ... FM0 data encoding
 101 ... FM1 data encoding
 110 ... MANCHESTER data encoding
 111 ... (not used).

SM1 ...SM0 ... Serial Mode

00 ... HDLC/SDLC mode
 01 ... SDLC Loop mode
 10 ... BISYNC mode
 11 ... ASYNC mode.

Detailed Register Description

Channel Configuration Register 1 (CCR1)

Access: read/write address: ch-A: 2D_H
ch-B: 6D_H

Value after RESET: 00_H

	7						0
CCR1	0	0	0	ODS	BCR	CM2	CM0

Note: Unused bits have to be set to logical '0'.

ODS ...

Output Driver Select

Defines the function of the transmit data pins (T×DA, T×DB)

0 ... TxD pin is an open drain output.

1 ... TxD pin is a push-pull output.

BCR ...

Bit Clock Rate

This bit is only valid in clock modes **not** using the DPLL (0, 1, 3b, 4, 7b).

0 ... selects isochronous operation with a bit clock rate = 1. Data is sampled once.

1 ... selects standard asynchronous operation with a bit clock rate = 16. Data is sampled 3 times around the nominal bit center. The effective bit value is determined by majority decision. For correct operation, **NRZ** data encoding has to be selected.

CM2 ... CM0 ...

Clock Mode

Selects one of 8 different clock modes:

000 clock mode 0

. . .

. . .

. . .

111 clock mode 7

*Note: Clock mode 5 is only specified for versions
SAB/SAF 82532 N-10 and SAB/SAF 82532 H-10,
but not for versions SAB 82532 N and SAB 82532 H.*

Detailed Register Description

Channel Configuration Register 2 (CCR2)

Access: read/write address: ch-A: 2E_H
 ch-B: 6E_H

Value after RESET: 00_H

The meaning of the individual bits in CCR2 depends on the clock mode selected via CCR1 as follows:

CCR2	7						0	
clock mode 0a, 1	SOC1	SOC0	0	0	0	RWX	0	DIV
clock mode 0b, 2, 3, 6, 7	BR9	BR8	BDF	SSEL	TOE	RWX	0	DIV
clock mode 4	SOC1	SOC0	0	0	TOE	RWX	0	DIV
clock mode 5	SOC1	SOC0	XCS0	RCS0	TOE	RWX	0	DIV

Note: Unused bits have to be set to logical '0'.

SOC1, SOC2 ...

Special Output

In a bus configuration (selected via CCR0) defines the function of pin RTS as follows:

0X ... RTS output is activated during transmission of characters.

10 ... RTS output is always 'high' (RTS disabled).

11 ... RTS indicates the reception of a data frame (active 'low').

In a point-to-point configuration (selected via CCR0) the TxD and RxD pins may be flipped.

0X ... data is transmitted on TxD, received on RxD (normal case).

1X ... data is transmitted on RxD, received on TxD.

BR9, BR8 ...

Baud Rate, Bit 9 ... 8

High order bits, see description of BGR register.

XCS0, RCS0 ...

Transmit/Receive Clock Shift, Bit 0

Together with XCS2, XCS1 (RCS2, RCS1) in TSAX (TSAR), determines the clock shift relative to the frame synchronization signal of the Transmit (Receive) time-slot.

A clock shift of 0 ... 7 bits is programmable (clock mode 5 only).

Detailed Register Description

BDF ...	Baud Rate Division Factor 0 ... The division factor of the baud rate generator is set to 1 (constant). 1 ... The division factor is determined by BR9 ... BR0 bits in CCR2 and BRG registers.
SSEL ...	Clock Source Select Selects the clock source in clock modes 0, 2, 3, 6 and 7 (refer to table 5).
TOE ...	TxCLK Output Enable 0 ... TxCLK pin is input 1 ... TxCLK pin is switched to output function if applicable to the selected clock mode (refer to table 5).
RWX ...	Read/Write Exchange Valid only in DMA mode. If this bit is set, the – \overline{RD} and \overline{WR} pins are internally exchanged (Siemens/INTEL bus interface) – $\overline{R/W}$ pin is inverted in polarity (Motorola bus interface) while any \overline{DACK} input is active. This useful feature allows a simple interfacing to the DMA controller. <i>Note: The RWX bit of both channels is 'OR' ed.</i>
DIV ...	Data Inversion Only valid if NRZ data encoding is selected. Data is transmitted and received inverted.

Detailed Register Description

Time-Slot Assignment Register Receive (TSAR)

Access: write address: ch-A: 31_H
ch-B: 71_H

Value after RESET: 00_H

Note: This register is only used in clock mode 5!

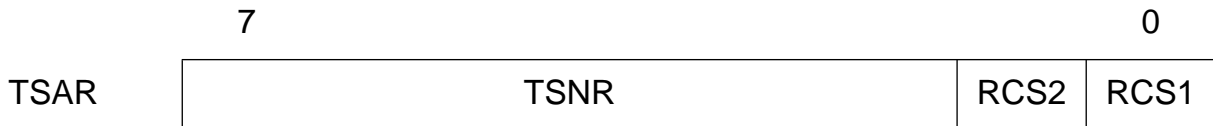

TSNR ...

Time-slot Number Receive

Defines one of up to 64 possible time-slots (00_H ... 3F_H) in which data is received. The number of bits per time-slot can be programmed via RCCR.

RCS2 ... RCS1 ...

Transmit Clock Shift, Bit 2 ... 1

Together with bit RCS0 in CCR2, transmit clock shift can be adjusted.

Transmit Channel Capacity Register (XCCR)

Access: write address: ch-A: 32_H
ch-B: 72_H

Value after RESET: 00_H

Note: This register is only used in clock mode 5!

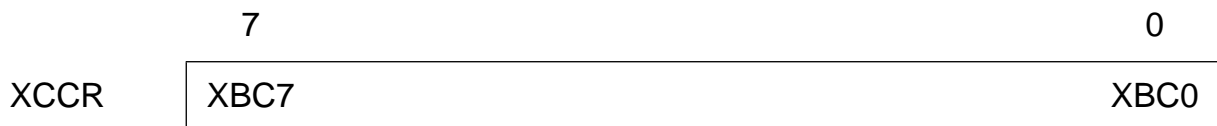

XBC7 ... XBC0 ...

Transmit Bit Number Count, Bit 7 ... 0

Defines the number of bits to be transmitted within a time-slot:
Number of bits = XBC + 1 (1 ... 256 bits/time-slot).

Detailed Register Description

Receive Channel Capacity Register (RCCR)

Access: write address: ch-A: 33_H
ch-B: 73_H

Value after RESET: 00_H

Note: This register is only used in clock mode 5!



RBC7 ... RBC0 ... Receive Bit Number Count, Bit 7 ... 0

Defines the number of bits to be transmitted within a time-slot:
Number of bits = RBC + 1 (1 ... 256 bits/time-slot).

Version Status Register (VSTR)

Access: read address: ch-A: 34_H
ch-B: 74_H

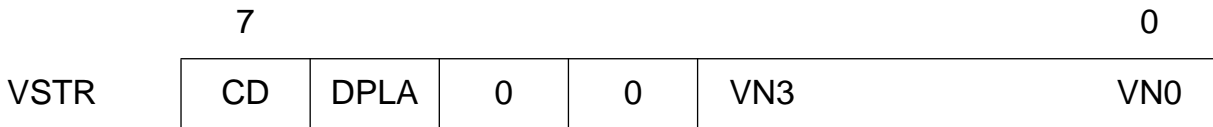

CD ... Carrier Detect

This bit reflects the state of the CD pin.
1 ... CD active
0 ... CD inactive

DPLA ... DPLL Asynchronous

This bit is only valid when the receive clock is supplied by the DPLL and FM0, FM1 or Manchester data encoding is selected.
It is set when the DPLL has lost synchronization. Reception is **not** disabled (IDLE is inserted) until synchronization has been regained. Additionally, transmission is interrupted, too, if the transmit clock is derived from the DPLL (same effect as the deactivation of pin CTS).

VN3 ... VN0 ... Version Number of Chip

0000 ... Version 1
0001 ... Version 2
0010 ... Version 3.2

Detailed Register Description

Baud Rate Generator Register (BGR)

Access: write address: ch-A: 34_H
ch-B: 74_H

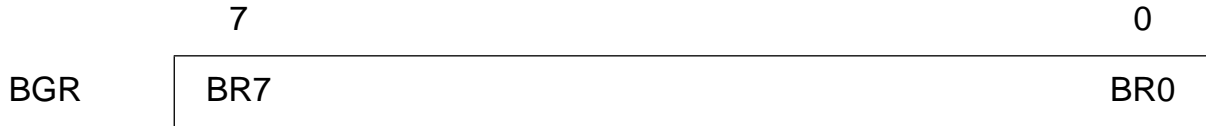

BR7 ... BR0 ...

Baud Rate, bits 7 ... 0

The Baud Rate generator divisor consist of bits BR0-7 from BRG register and bits BR8-9 from the CCR2 register.

The baud rate generator has two modes of operation giving added flexibility.

Standard Mode:

bits BR9-0 give a value N (N = 0 ... 1023) to give a XTAL clock division factor k:

$$k = (N + 1) \times 2$$

Enhanced Mode:

This consists of a 2 stage divider. The first stage is divisor N is determined by bits BR5 ... BR0 (N = 0 ... 63) while the second stage divisor M is determined by bit BR9 ... BR6 (M = 0 ... 15). The first stage divides the clock by integer number up to 63, where the second stage allows further division by powers of 2 (1, 2, 4, 8, 16, 32, 64, 128 ... 32768).

Division by 1 using M = 0 is restricted to frequencies below 10 MHz (to be characterized). The XTAL clock division factor k:

$$k = (N + 1) \times 2^M$$

The Baud Rate generator is typically used to derive clocks for DTE or DCE Asynchronous baud rates with 16- \times oversampling mode. **Appendix A** shows baud rates derived from typical XTAL frequencies using the two modes of the baud rate generator for ASYNC operation with 16- \times oversampling enabled.

Detailed Register Description

Mask XON Character (MXN) (Version 2 upwards)

Access: write address: ch-A: 36_H
ch-B: 76_H

Value after RESET: 00_H



This register is used to masked single bit positions of the XON character. Refer to the description of the XON register. The number of significant bits is determined by the programmed character length (right justified).

A '1' in the mask register has the effect that no comparison is performed between the corresponding bits in the received characters ('don't cares') and the XON register. At RESET, the mask register is zeroed, i.e. all bit positions are compared.

Mask XOFF Character (MXF) (Version 2 upwards)

Access: write address: ch-A: 37_H
ch-B: 77_H

Value after RESET: 00_H



This register is used to mask single bit positions of the XOFF character. Refer to the description of the XOFF register. The number of significant bits is determined by the programmed character length (right justified).

A '1' in the mask register has the effect that no comparison is performed between the corresponding bits in the received characters ('don't cares') and the XOFF register. At RESET, the mask register is zeroed. i.e. all bit positions are compared.

Detailed Register Description**Global Interrupt Status Register (GIS)**

Access: read address: ch-A: 38_H
ch-B: 78_H

Value after RESET: 00_H

	7							0
GIS	PI	0	0	0	ISA1	ISA0	ISB1	ISB0

This status register points to pending

- channel assigned interrupts:
ISA0 → ISR0, ISA1 → ISR1 on channel A
ISB0 → ISR0, ISB1 → ISR1 on channel B
- universal port interrupts:
PI → PIS.

It is accessible via both channel addresses (38_H or 78_H). As opposed to the 'real' interrupt status registers (ISR0, ISR1, PIS), its contents are not cleared after a read access. The bits in GIS are individually reset when the corresponding interrupt status register has been read.

Interrupt Vector Address (IVA)

Access: write address: ch-A: 38_H
ch-B: 78_H

Value after RESET: 00_H

	7					0
IVA	T7	T3	0	0	0	

Note: Unused bit have to be set to logical '0'.

IVA is accessible via both channel addresses (38_H or 78_H).

T3 ... T7 ...**Interrupt Vector Address**

These bits define the value of bits 3 to 7 of the interrupt vector which is sent out on the data bus (D0 ... D7) during the interrupt acknowledge cycle.

Detailed Register Description

Interrupt Port Configuration (IPC)

Access: read/write address: ch-A: 39_H
 ch-B: 79_H

Value after RESET: 00_H

	7							0
IPC	VIS	0	0	SLA1	SLA0	CASM	IC1	IC0

Note: Unused bits have to be set to logical '0'.

IPC is accessible via both channel addresses (39_H or 79_H).

VIS ... Masked Interrupts Visible

- 0 ... Masked interrupt status bits are not visible
- 1 ... Masked interrupt status bits are visible.

SLA1 ... SLA0 ... Slave Address

Only used in Slave Cascading mode (refer to CASM).

CASM ... Cascading Mode

- 0 ... Slave Cascading Mode
 Pins IE0, IE1 are used as inputs. Interrupt acknowledge is accepted if an interrupt signal has been generated and the values on pins IE0 and IE1 correspond to the programmed values.
- 1 ... Daisy Chaining Mode
 Pin IE0 as Interrupt Enable Output and pin IE1 as Interrupt Enable Input are used for building a Daisy Chain. Interrupt acknowledge is accepted if an interrupt signal has been generated and Interrupt Enable Input IE1 is active 'high' during a subsequent INTA cycle. If pin INT goes active, Interrupt Enable Output IE0 is immediately set to 'low'.

IC1 ... IC0 ... Interrupt Port Configuration

These bits define the function of the interrupt output stage (pin INT):

IOC1	IOC0	Function
x	0	Open drain output
0	1	Push/Pull output, active 'low'
1	1	Push/Pull output, active 'high'

Detailed Register Description

Interrupt Status Register 0 (ISR0)

Access: read address: ch-A: 3A_H
 ch-B: 7A_H

Value after RESET: 00_H

	7							0
ISR0	TCD	TIME	PERR	FERR	PLLA	CDSC	RFO	RPF

All bits are reset when ISR0 is read. Additionally, TCD and RPF are reset when the corresponding interrupt vector is output.

Note: If bit IPC:VIS is set to '1', interrupt statuses in ISR0 may be flagged although they are masked via register IMR0. However, these masked interrupt statuses neither generate an interrupt vector or a signal on INT, nor are visible in register GIS.

TCD ... Termination Character Detected
 The termination character (TCR) has been received or the execution of the RFRD command issued before has been completed. A data block is now available in the RFIFO. The actual block length can be determined by reading register RBCL first.

TIME ... Time OUT
 The time-out limit has been exceeded.
 If the respective mask bit is reset (i.e. TIME interrupt is enabled), the received data stream is monitored for exceeding the fixed time limit after the last character has been received (time limit = 4 × CFL; character frame length CFL includes start bit, character length, parity bit and stop bits).

PERR ... Parity Error
 Only valid if parity check/generation is enabled.
 If set, a character with parity error has been received. If enabled via RFDF, parity error information is stored in RFIFO in the status byte pertaining to that character.

FERR ... Framing Error
 This bit indicates that a character has been received with a framing error, i.e. the receiver has detected a '0' in a stop bit position. If enabled via RFDF, this information is stored in RFIFO in the status byte pertaining to that character.

Detailed Register Description

BRK ...	Break This bit is set when a break signal – static low level for a time equal to (character length + parity + stop bit(s)) – is detected on RxD.
BRKT ...	Break Terminated This bit is set when a Break signal on RxD is terminated.
ALLS ...	All Sent This bit is set when the XFIFO is empty and the last character is completely sent out on T × D.
XOFF ...	XOFF Character Detected This interrupt status indicates that the currently received character matches the value specified via register XOFF. The function is independent of the programming of bit MODE.FLON.
TIN ...	Timer Interrupt The internal timer has expired (see also description of TIMR register).
CSC ...	Clear To Send Status Change Indicates that a state transition has occurred on $\overline{\text{CTS}}$. The actual state of CTS can be read from STAR register (CTS bit).
XON ...	XON Character Detected This interrupt status indicates that the currently received character matches the value specified via register XON. The function is independent of the programming of bit MODE.FLON.
XPR ...	Transmit Pool Ready A data block of up to 32 bytes can be written to XFIFO.

Detailed Register Description

Interrupt Mask Register 0, 1 (IMR0, IMR1)

Access: write address: ch-A: 3A_H (IMR0), 3B_H (IMR1)
 ch-B: 7A_H (IMR0), 7B_H (IMR1)

Value after RESET: FF_H, FF_H

	7							0
IMR0	TCD	1	PERR	SCD	PLLA	CDSC	RFO	RPF
IMR1	1	1	ALLS	XDU	TIN	CSC	XMR	XPR

Note: Unused bits have to be set to logical '1'.

Each interrupt source can generate an interrupt signal at port INT (function of the output stage is defined via register IPC). A '1' in a bit position of IMR0 or IMR1 sets the mask active for the interrupt status in ISR0 or ISR1. Masked interrupt statuses neither generate an interrupt vector or a signal on INT, nor are they visible in register GIS. Moreover, they will

- not be displayed in the Interrupt Status Register if bit IPC:VIS is set to '0'
- be displayed in the Interrupt Status Register if bit IPC:VIS is set to '1'

*Note: After RESET, all interrupts are **disabled**.*

Port Value Register (PVR)

Access: read/write address: ch-A: 3C_H
 ch-B: 7C_H

	7		0
PVR	PVR7		PVR0

PVR is accessible via both channel addresses (3C_H or 7C_H).

Each of the above bits is assigned to the Universal Port pin (P0 ... P7) with the same number.

Read Access

PVR shows the value of all pins (input and output). Input values can be separated via software by 'AND'-ing PCR and PVR.

Write Access

PVR accepts values for all output pins (defined via PCR). Values written to input pin locations are ignored.

Detailed Register Description

Port Interrupt Status Register (PIS)

Access: read address: ch-A: 3D_H
ch-B: 7D_H



PIS is accessible via both channel addresses (3D_H or 7D_H).

Each of the above bits is assigned to the Universal Port pin (P0 ... P7) with the same number. Bit PIS_n is set and an interrupt is generated on INT if

- the corresponding Universal Port pin P_n is defined as input via register PCR and
- the interrupt source is enabled by resetting the corresponding interrupt mask PIM_n in register PIM and
- a state transition has occurred on pin P_n. For definite detection of a real state transition, pulse width should not be shorter than 20 ns.

Note: Bits PIS_n are reset when register PIS is read. Masked interrupts are not normally indicated when PIS is read. Instead, they remain internally stored and pending. A pending interrupt is generated when the corresponding mask bit is reset to zero. However, if bit IPC:VIS is set to '1', interrupt statuses in PIS may be flagged although they are masked via register PIM. These masked interrupt statuses neither generate an interrupt vector or a signal on INT, nor are visible in register GIS. If more than one consecutive state transition occurs on the same pin before the PIS register is read, only one interrupt request will be generated.

Detailed Register Description

10.3 Status/Control Registers in BISYNC Mode

10.3.1 Register Addresses

Address (A0 ... A6)		Register		Meaning	Refer to Page
Channel		Read	Write		
A	B				
00	40	RFIFO	XFIFO	Receive/Transmit FIFO	201/203
.	.				
.	.				
1F	5F				
20	60	STAR	CMDR	Status Register/Command Register	204/205
21	61	–	PRE	Preamble Register	206
22	62	MODE		Mode Register	207
23	63	TIMR		Timer Register	208
24	64	SYNL		Sync Character Low	210
25	65	SYNH		Sync Character High	210
26	66	TCR		Termination Character Register	211
27	67	DAFO		Data Format	212
28	68	RFC		RFIFO Control Register	213
29	69	–		–	–
2A	6A	RBCL	XBCL	Receive Byte Count Low/Transmit Byte Count Low	215/215
2B	6B	RBCH	XBCH	Receive/Transmit Byte Count High	216/217
2C	6C	CCR0		Channel Configuration Register 0	218
2D	6D	CCR1		Channel Configuration Register 1	219
2E	6E	CCR2		Channel Configuration Register 2	220
2F	6F	CCR3		Channel Configuration Register 3	222

Detailed Register Description

10.3.1 Register Addresses (cont'd)

Address (A0 ... A6)		Register		Meaning	Refer to Page
Channel		Read	Write		
A	B				
30	70	–	TSAX	Time-slot Assignment Register Transmit	223
31	71	–	TSAR	Time-slot Assignment Register Receive	224
32	72	–	XCCR	Transmit Channel Capacity Register	224
33	73	–	RCCR	Receive Channel Capacity Register	225
34	74	VSTR	BGR	Version Status/Baud Rate Generator Register	226/227
35	75	–	–	–	–
36	76	–	–	–	–
37	77	–	–	–	–
38	78	GIS ¹⁾	IVA ¹⁾	Global Interrupt Status/Interrupt Vector Address	228/228
39	79	IPC ¹⁾		Interrupt Port Configuration	229
3A	7A	ISR0	IMR0	Interrupt Status 0/Interrupt Mask 0	230/232
3B	7B	ISR1	IMR1	Interrupt Status 1/Interrupt Mask 1	231/232
3C	7C	PVR		Port Value Register	233
3D	7D	PIS ¹⁾	PIM ¹⁾	Port Interrupt Status/Port Interrupt Mask	234/235
3E	7E	PCR ¹⁾		Port Configuration Register	236
3F	7F	CCR4		Channel Configuration Register	237

¹⁾ Both channel assigned addresses enable access to the same register(s).

*Note: Read access to unused register addresses: value should be ignored,
Write access to unused register addresses: should be avoided, or set to '00_H'.*

10.3.2 Register Definitions

Receive FIFO (RFIFO)

Access: read address: ch-A: 00 ... 1F_H
ch-B: 40 ... 5F_H

Received data stored in RFIFO (LSB is received first) can be organized in one of two selectable ways (refer to figure 51):

- pure data up to a character length of 8 bits (incl. optional parity)
- additionally, one status byte per character with information about parity and parity error (if enabled).

Reading data from RFIFO can be done in 8-bit (byte) or 16-bit (word) access depending on the selected bus interface mode. The LSB is received first from the serial interface.

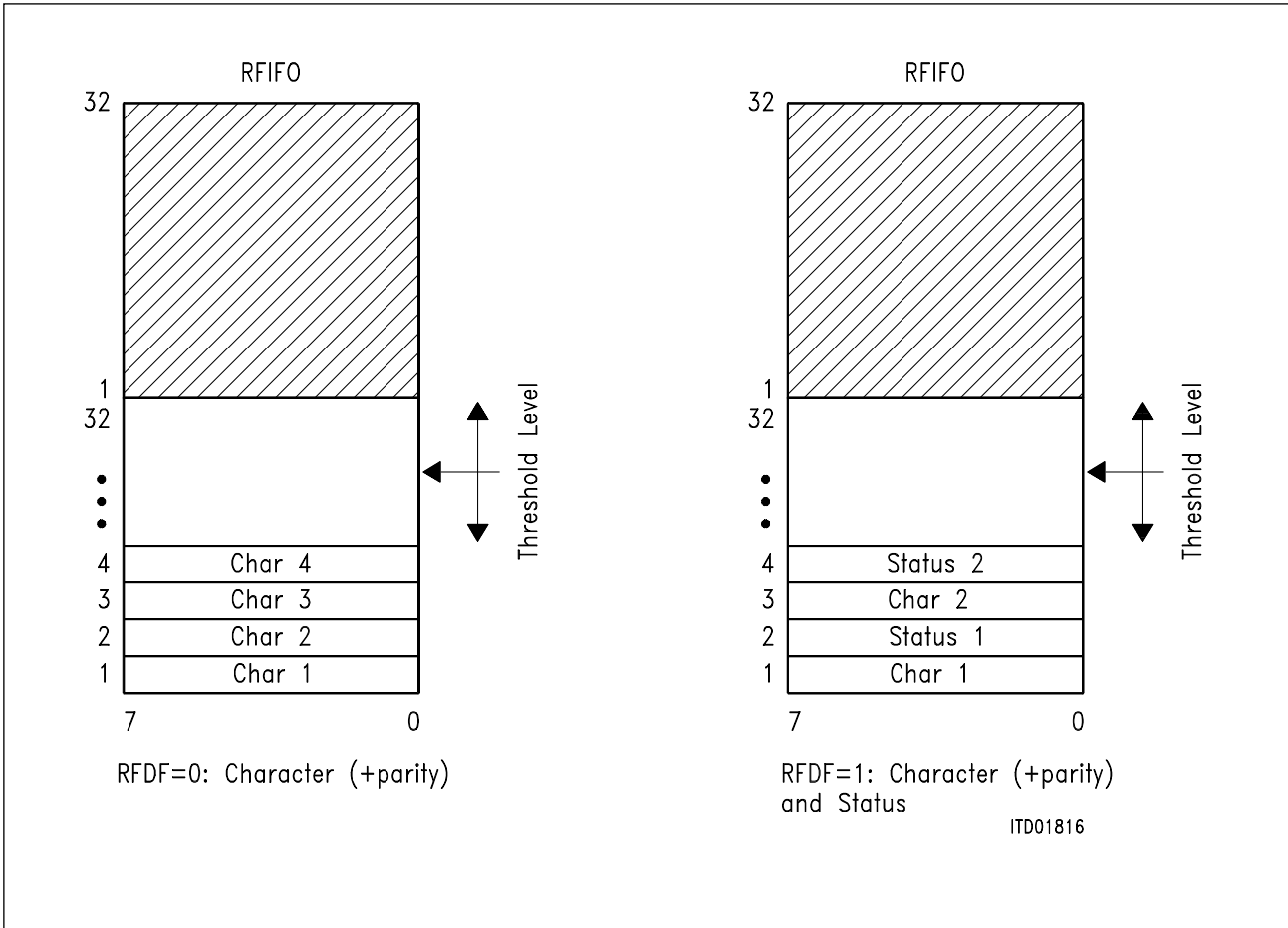

Figure 52
Organization of RFIFO

Detailed Register Description**Interrupt Controlled Data Transfer (interrupt mode)**

Selected if DMA bit in XBCH is set to '0'.

Up to 32 bytes/16 words of received data can be read from the RFIFO following a RPF or a TCD interrupt depending on the selected RFIFO mode (refer to RFC register):

RPF interrupt: A fixed number of bytes/words (programmed threshold level RFTHO, 1) has to be read by the CPU.

TCD interrupt: Termination character detected. The received data stream is monitored for a 'termination character' (programmable via register TCR). The number of valid bytes in RFIFO is determined by reading the RBCL register.

If necessary, the CPU can have access to RFIFO by issuing RFIFO Read command (CMDR.RFRD) before threshold level or termination character condition is reached. The number of valid **bytes** is determined by reading the RBCL register. Additional information: STAR:RFNE: RFIFO Not Empty.

DMA Controlled Data Transfer (DMA mode)

Selected if DMA bit in XBCH is set.

If the RFIFO contains the number of bytes/words defined by the threshold level, the ESCC2 autonomously requests a block data transfer by DMA by activating the DRRn line until the last valid data is read (the DRRn line remains active up to the beginning of the last read cycle).

This forces the DMA controller to continuously perform bus cycles till all data is transferred from the ESCC2 to the system memory (level triggered transfer mode of DMA controller). If the end condition (TCD) is reached, the same procedure as above is performed. DRRn is activated until the termination character is transferred, at which time a TCD interrupt is generated. Generation of further DMA requests is blocked until TCD interrupt has been acknowledged by issuing an RMC command. The valid **byte** count of the last block can be determined by reading the RBCL register following the TCD interrupt.

Note: Addresses within the 32-byte address space of the FIFO point all to the same byte/word, i.e. current data can be accessed with any address within the valid range.

Detailed Register Description

Status Register (STAR)

Access: read address: ch-A: 20_H
ch-B: 60_H

Value after RESET: 40_H

	7						0	
STAR	XDOV	XFW	RFNE	SYNC	0	CEC	CTS	0

XDOV ... Transmit Data Overflow
More than 32 bytes have been written to the XFIFO.
This bit is reset by:

- a transmitter reset command XRES
- or when all bytes in the accessible half of the XFIFO have been moved into the inaccessible half.

XFW ... Transmit FIFO Write Enable
Data can be written to the XFIFO.

RFNE ... RFIFO Not Empty
This bit is set if the accessible part of RFIFO holds at least one valid byte.

SYNC ... Synchronization Status
The bit is reset after the HUNT command has been issued. It indicates that the receiver has lost synchronization and is searching for the presence of a SYN character. If found, SYNC will be immediately set, the SCD interrupt is generated (if enabled), and filling the RFIFO with received data is started.

CEC ... Command Executing
0 ... no command is currently being executed, the CMDR register can be written to.
1 ... a command (written previously to CMDR) is currently being executed, no further command can be temporarily written into CMDR register.
Note: CEC will be active at most 2.5 transmit clock periods. If the ESCC2 is in power-down mode CEC will stay active.

CTS ... Clear To Send State
This bit indicates the state of the $\overline{\text{CTS}}$ pin.
0 ... $\overline{\text{CTS}}$ is inactive (high)
1 ... $\overline{\text{CTS}}$ is active (low).

Detailed Register Description

Command Register (CMDR)

Access: write address: ch-A: 20_H
ch-B: 60_H

Value after RESET: 00_H

	7							0
CMDR	RMC	RRES	RFRD	STI	XF	HUNT	XME	XRES

- RMC ... Receive Message Complete**
Confirmation from CPU to ESCC2 that the current frame or data block has been fetched following an RPF or RME interrupt, thus the occupied space in the RFIFO can be released.
Note: In DMA Mode, this command has to be issued after an TCD interrupt in order to enable the generation of further receiver DMA requests.
- RRES ... Receiver Reset**
All data in RFIFO and receiver is deleted. The receiver returns to Hunt state.
- RFRD ... Receive FIFO Read Enable**
The CPU can have access to RFIFO by issuing the RFRD command before threshold level or the end condition (TCD) are fulfilled. After issuing the RFRD command the CPU has to wait for TCD interrupt, before reading RBC and RFIFO. The number of valid **bytes** is determined by reading the RBCL register.
- STI ... Start Timer**
The internal timer is started.
Note: The timer is stopped by rewriting the TIMR register after start.
- XF ... Transmit Frame**
- **Interrupt Mode**
After having written up to 32 bytes/16 words to the XFIFO, this command initiates the transmission of data.
 - **DMA Mode**
After having written the amount of data to be transmitted to the XBCH, XBCL registers, this command initiates the data transfer from system memory to ESCC2 by DMA. Serial data transmission starts as soon as 32 bytes/16 words are stored in the XFIFO or the Transmit Byte Counter value is reached.

Detailed Register Description

Mode Register (MODE)

Access: read/write address: ch-A: 22_H
ch-B: 62_H

Value after RESET: 00_H

	7							0
MODE	0	0	SLEN	BISNC	RAC	RTS	TRS	TLP

Note: Unused bits have to be set to logical '0'.

SLEN ... SYN Character Length

This bit selects the length of the SYN character:

0 ... 6 bit (MONOSYNC)/12 bit (BISYNC)

1 ... 8 bit (MONOSYNC) /16 bit (BISYNC).

BISNC ... Enable Bisync Mode

0 ... MONOSYNC mode is enabled (6/8 bit SYN character defined via register SYNL).

1 ... BISYNC mode is enabled (12/16 bit SYN character defined via registers SYNL and SYNH). SYNL is received/transmitted first.

RAC ... Receiver Active

Switches the receiver to operational or inoperational state.

0 ... receiver inactive

1 ... receiver active.

RTS ... Request To Send

Defines the state and control of $\overline{\text{RTS}}$ pin.

0 ... The $\overline{\text{RTS}}$ pin is controlled by the ESCC2 autonomously.

$\overline{\text{RTS}}$ is activated when data transmission starts and deactivated when transmission is completed.

1 ... The $\overline{\text{RTS}}$ pin is controlled by the CPU.

If this bit is set, the $\overline{\text{RTS}}$ pin is activated immediately and remains active till this bit is reset.

TRS ... Timer Resolution

Selects the resolution of the internal timer (factor k, see description of TIMR register):

0 ... k = 32 768

1 ... k = 512

Detailed Register Description

TLP ...

Test Loop

Input and output of the serial interface are internally connected.
 (transmitter channel A - receiver channel A/
 transmitter channel B - receiver channel B)

Timer Register (TIMR)

Access: read/write

address: ch-A: 23_H
 ch-B: 63_H

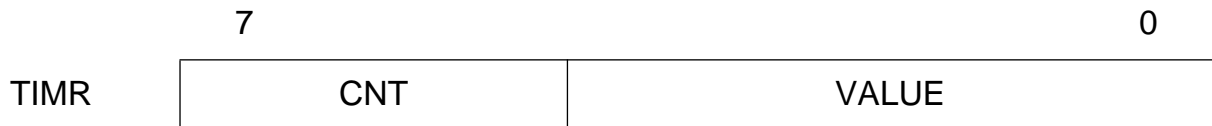

VALUE ...

(5 bits) Sets the time period t_1 as follows:

$$t_1 = k \times (\text{VALUE} + 1) \times \text{TCP}$$

where

- k is the timer resolution factor which is either 32 768 or 512 clock cycles dependent on the programming of TRS bit in MODE.
- TCP is the clock period of transmit data (CCR0:MCE = '0') or master clock (CCR0:MCE = '1').

CNT ...

(3 bits)

CNT plus VALUE determine the time period t_2 after which a timer interrupt will be generated. The time period t_2 is

$$t_2 = 32 \times k \times \text{CNT} \times \text{TCP} + t_1.$$

If CNT is set to 7, a timer interrupt is periodically generated after the expiration of t_1 .

Detailed Register Description

Version 3.x:

TIMR Timer Register (READ/WRITE) is unchanged. However the input to the timer function can be optionally selected to be XTAL/4 in master clock mode by setting CCR0:MCE = '1' and CCR4:MCK4 = '1'.

VALUE ... (5 bits) sets the time period t_1 as follows:
 With CCR4:MCK4 = '0' and default condition, the timer value is given by the equation

$$t_1 = k \times (\text{VALUE} + 1) \times \text{TCP}$$
 where
 – k is the timer resolution factor which is either 32 768 (if MODE:TRS = '0') or 512 (if MODE:TRS = '1') clock cycles.
 – TCP is the clock period of the timer clock.

Non Master Clock Mode (CCR0:MCE = '0')

Timer Clock Period (TCP) = Transmit Clock Period

Master Clock Mode (CCR0:MCE = '1')

if CCR4:MCK4 = '0' (Reset state)

Timer Clock Period (TCP) = XTAL Clock Period

if CCR4:MCK4 = '1'

Timer Clock Period (TCP) = XTAL Clock Period/4

With CCR4:MCK4 = '1' in master clock mode, XTAL clock divide-by-4 is fed to the timer block. The XTAL clock feeds the baud rate generator which is used to select the transmit and received baud rate and generates the 16- \times oversampling clock. By this means, a XTAL clock of 30 MHz can be used while maintaining the Core logic's clock operation limit of 10 MHz.

CNT ... (3 bits) The CNT function is unchanged.

Detailed Register Description

SYN Character Register Low, High (SYNL, SYNH)

Access: read/write address: ch-A: 24_H (SYNL), 25_H (SYNH)
ch-B: 64_H (SYNL), 65_H (SYNH)

Value after RESET: 00_H, 00_H

	7	0
SYNL	SYNL	
SYNH	SYNH	

In conjunction with bit BISNC and bit SLEN the SYN character can be specified:

- MONOSYNC mode (BISNC = '0')
The SYN character is defined by SYNL.
SLEN = '0': the SYN character is specified by bits 0 ... 5
SLEN = '1': the SYN character is specified by bits 0 ... 7.
- BISYNC mode (BISNC = '1')
The SYN character is defined by SYNL (low byte) and SYNH (high byte).
SLEN = '0': the 12-bit SYN character is specified by bits 0 ... 5 of both SYNL and SYNH.
SLEN = '1': the 16-bit SYN character is specified by bits 0 ... 7 of both SYNL and SYNH.
SYNL is received/transmitted first.

In transmit direction, the SYN character thus specified is sent continuously when no data are to be transmitted, if ITF (Interframe Time Fill) control bit is set to '1'.

In receive direction, the receiver searches for the specified SYN character in the receive data stream, when in the hunt mode.

Detailed Register Description

Data Format (DAFO)

Access: read/write address: ch-A: 27_H
ch-B: 67_H

Value after RESET: 00_H

	7							0
DAFO	0	0	0	PAR1	PAR0	PARE	CHL1	CHL0

Note: Unused bits have to be set to logical '0'.

PAR1, PAR0 ... Parity Format

If parity check/generation is enabled by setting PARE, these bits define the parity format:

- 00 ... SPACE ('0')
- 01 ... odd parity
- 10 ... even parity
- 11 ... MARK ('1')

The received parity bit is stored in RFIFO

- as leading bit immediately preceding the character if character length is 5 to 7 bits and RFC.DPS is set to '0', and as LSB of the status byte pertaining to the character if the corresponding RFIFO data format is enabled,
- as LSB of the status byte pertaining to the character if character length is 8 bits and the corresponding RFIFO data format is enabled.

Parity error is indicated in the MSB of the status byte pertaining to the character, if enabled. Additionally, a parity error interrupt can be generated.

PARE ... Parity Enable

- 0 ... parity check/generation disabled
- 1 ... parity check/generation enabled.

CHL1 ... CHL0 ... Character Length

These bits define the length of received/transmitted characters, excluding optional parity:

- 00 ... 8 bit
- 01 ... 7 bit
- 10 ... 6 bit
- 11 ... 5 bit.

Detailed Register Description

RFDF = '0'	RFDF = '1'																								
<ul style="list-style-type: none"> character 5 ... 8 bit <p>or</p> <ul style="list-style-type: none"> character 5 ... 7(8)¹ bit + parity <p>¹) Parity bit is lost.</p>	<ul style="list-style-type: none"> character 5 ... 8 bit + status <p>or</p> <ul style="list-style-type: none"> character 5 ... 7(8)¹ bit + parity + status <p>¹) Parity bit is in status byte.</p>																								
<div style="text-align: center;"> 7 4 0 </div> <table border="1" style="width: 100%; border-collapse: collapse;"> <tr> <td style="width: 20px;">Data Byte</td> <td style="width: 20px; text-align: center;">7</td> <td style="width: 20px;"></td> <td style="width: 20px; text-align: center;">(P)</td> <td style="width: 20px;"></td> <td style="width: 20px; text-align: center;">Char</td> <td style="width: 20px;"></td> <td style="width: 20px; text-align: center;">0</td> </tr> </table>	Data Byte	7		(P)		Char		0	<div style="text-align: center;"> 7 4 0 </div> <table border="1" style="width: 100%; border-collapse: collapse;"> <tr> <td style="width: 20px;">Data Byte</td> <td style="width: 20px; text-align: center;">7</td> <td style="width: 20px;"></td> <td style="width: 20px; text-align: center;">(P)</td> <td style="width: 20px;"></td> <td style="width: 20px; text-align: center;">Char</td> <td style="width: 20px;"></td> <td style="width: 20px; text-align: center;">0</td> </tr> </table> <div style="text-align: center;"> 7 0 </div> <table border="1" style="width: 100%; border-collapse: collapse;"> <tr> <td style="width: 20px;">Data Byte</td> <td style="width: 20px; text-align: center;">7</td> <td style="width: 20px;"></td> <td style="width: 20px; text-align: center;">PE</td> <td style="width: 20px;"></td> <td style="width: 20px;"></td> <td style="width: 20px;"></td> <td style="width: 20px; text-align: center;">P</td> </tr> </table>	Data Byte	7		(P)		Char		0	Data Byte	7		PE				P
Data Byte	7		(P)		Char		0																		
Data Byte	7		(P)		Char		0																		
Data Byte	7		PE				P																		

FE: framing error PE: parity error P: parity bit
(P): can be disabled via bit DPS

RFTH1, RFTH0 ...

RFIFO Threshold Level

These bits define the level up to which RFIFO is filled with valid data:

RFTH1, 0	Threshold Level (bytes)	
	RFDR = '0'	RFDF = '1'
00	1 (1d)	2 (1d + 1s)
01	4 (4d)	4 (2d + 2s)
10	16 (16d)	16 (8d + 8s)
11	32 (32d)	32 (16d + 16s)

d: data byte

s: status byte

If the threshold level is reached, the RPF interrupt is generated if enabled. After RPF is generated, the contents of RFIFO (RFTH bytes) can be read by the CPU. To indicate that this RFIFO pool can be released, an RMC command has to be issued.

TCDE ...

Termination Character Detection Enable

When this bit is set, the received data stream is monitored for 'termination character' (TCR register). When such a character occurs, the TCD interrupt is generated if enabled via mask register IMR0. The number of **bytes** to be read from RFIFO is determined by the value of RBCL. To activate reception again the command CMD.HUNT has to be issued.

Detailed Register Description

Receive Byte Count Low (RBCL)

Access: read address: ch-A: 2A_H
ch-B: 6A_H



Indicates the number of valid bytes available in the accessible part of the RFIFO. This register must be read by the CPU following a TCD interrupt. In case of a TCD interrupt the number of valid bytes in the accessible part of the RFIFO can be evaluated by 'AND'-ing the contents of RBCL with: threshold level (bytes) – 1.

Threshold Level	Mask
4	03 _H
16	0F _H
32	1F _H

RBC is reset with RMC after preceding TCD interrupt.
In case of RPF interrupt RBC is incremented by 'threshold level (bytes)'.

Transmit Byte Count Low (XBCL)

Access: write address: ch-A: 2A_H
ch-B: 6A_H



Together with XBCH (bits XBC11 ... XBC8) this register is used in DMA mode only, to program the length (1 ... 4096 bytes) of the next data block to be transmitted.
In terms of the value xbc, programmed in XBC11 ... XBC0 (xbc = 0 ... 4095), the length of the block in number of bytes is:

$$\text{length} = \text{xbc} + 1.$$

This allows the ESCC2 to request the correct amount of DMA cycles after an XF command in CMDR.

Detailed Register Description

Received Byte Count High (RBCH)

Access: read address: ch-A: 2B_H
ch-B: 6B_H

Value after RESET: 000xxxxx

	7					0
RBCH	DMA	0	CAS	0	RBC11	RBC8
	see XBCH					

DMA, CAS ... These bits represent the read-back value programmed in XBCH

RBC11 ... RBC8 ... Receive Byte Count (most significant bits)

No function.

Detailed Register Description

Transmit Byte Count High (XBCH)

Access: write address: ch-A: 2B_H
ch-B: 6B_H

Value after RESET: 000xxxxx

	7					0
XBCH	DMA	0	CAS	XC	XBC11	XBC8

Note: Unused bits have to be set to logical '0'.

- DMA ... DMA Mode**
 Selects the data transfer mode of ESCC2 to/from System Memory.
 0 ... Interrupt controlled data transfer (Interrupt Mode).
 1 ... DMA controlled data transfer (DMA Mode).
- CAS ... Carrier Detect Auto Start**
 When set, a 'high' on the CD pin enables the corresponding receiver and data reception is started. When not set, if not in Clock Mode 1 or 5, the CD pin can be used as a general input.
- XC ... Transmit Continuously**
 Only valid if DMA Mode is selected.
 If the XC bit is set, the ESCC2 continuously requests for transmit data ignoring the transmit byte count programmed via XBCH, XBCL. The byte count programmed via XBCH, XBXL, however, must be set to a value different from '0'.
- XBC11 ... XBC8 ... Transmit Byte Count (most significant bits)**
 Valid only if DMA Mode is selected.
 Together with XBCL (bits XBC7 ... XBC0), determine the number of characters to be transmitted.

Detailed Register Description

Channel Configuration Register 0 (CCR0)

Access: read/write address: ch-A: 2C_H
ch-B: 6C_H

Value after RESET: 00_H

	7							0
CCR0	PU	MCE	0	SC2	SC1	SC0	SM1	SM0

Note: Unused bits have to be set to logical '0'.

PU ... Switches between Power-up and Power-down Mode

- 0 ... power-down (standby)
- 1 ... power-up (active).

MCE ... Master Clock Enable

If this bit is set to '1', the clock provided via pin XTAL1 works as master clock to allow full functionality of the microprocessor interface (access to all status and control registers and FIFOs, DMA and interrupt support) independent of the receive and the transmit clocks. The internal oscillator in conjunction with a crystal on XTAL1-2 can be used, too. The master clock option is not applicable in clock mode 5. Refer to **table 5** for more details.

Note: The internal timers run with the master clock.

SC2 ... SC0... Serial Port Configuration

- 000 ... NRZ data encoding
- 001 ... (not recommended)
- 010 ... NRZI data encoding
- 011 ... (not recommended)
- 100 ... FM0 data encoding
- 101 ... FM1 data encoding
- 110 ... MANCHESTER data encoding
- 111 ... (not used).

Note: If bus configuration is selected, only NRZ coding is supported.

SM1 ...SM0 ... Serial Mode

- 00 ... HDLC/SDLC mode
- 01 ... SDLC Loop mode
- 10 ... BISYNC mode
- 11 ... ASYNC mode.

Detailed Register Description

BDF ...	Baud Rate Division Factor 0 ... The division factor of the baud rate generator is set to 1 (constant). 1 ... The division factor is determined by BR9 ... BR0 bits in CCR2 and BRG registers.
SSEL ...	Clock Source Select Selects the clock source in clock modes 0, 2, 3, 6 and 7 (refer to table 5).
TOE ...	TxCLK Output Enable 0 ... TxCLK pin is input 1 ... TxCLK pin is switched to output function if applicable to the selected clock mode (refer to table 5).
RWX ...	Read/Write Exchange Valid only in DMA mode. If this bit is set, the – \overline{RD} and \overline{WR} pins are internally exchanged (Siemens/INTEL bus interface) – $\overline{R/W}$ pin is inverted in polarity (Motorola bus interface) while any \overline{DACK} input is active. This useful feature allows a simple interfacing to the DMA controller. <i>Note: The RWX bit of both channels is 'OR' ed.</i>
DIV ...	Data Inversion Only valid if NRZ data encoding is selected. Data is transmitted and received inverted.

Detailed Register Description

CAPP ...

CRC Append

If this bit is set, the internal transmit CRC generator is activated:

1. The CRC generator is initialized every time the transmission of a new frame starts. Initialization value is defined via bit CRL.
2. During transmission all data with the CON bit set to '1' are included into CRC checksum calculation.
3. The checksum is automatically appended to the last transmitted data of the frame if a Transmit Message End command (XME) has been issued.

CRCM ...

Select CRC Algorithm

Selects the CRC algorithm for the internal transmit CRC generator:

- 0 ... CRC-16 $(X^{16} + X^{15} + X^2 + 1)$
- 1 ... CRC-CCITT $(X^{16} + X^{12} + X^5 + 1)$

PSD ...

DPLL Phase Shift Disable

Only applicable in the case of NRZ and NRZI encoding.
If this bit is set to '1', the Phase Shift function of the DPLL is disabled. In this case the windows for Phase Adjustment are extended.

Time-slot Assignment Register Transmit (TSAX)

Access: write address: ch-A: 30_H
ch-B: 70_H

Value after RESET: 00_H

Note: This register is only used in clock mode 5.

	7		0
TSAX	TSNX		XCS2 XCS1

TSNX ...

Time-slot Number Transmit

Selects one of up 64 possible time-slots (00_H ... 3F_H) in which data is transmitted. The number of bits per time-slot can be programmed via XCCR.

XCS2 ... XCS1 ...

Transmit Clock Shift, Bit 2 ... 1

Together with bit XCS0 in CCR2, transmit clock shift can be adjusted.

Detailed Register Description

Time-slot Assignment Register Receive (TSAR)

Access: write address: ch-A: 31_H
ch-B: 71_H

Value after RESET: 00_H

Note: This register is only used in clock mode 5.



TSNR ... Time-slot Number Receive

Defines one of up to 64 possible time-slots (00_H ... 3F_H) in which data is received. The number of bits per time-slot can be programmed via RCCR.

RCS2 ... RCS1 ... Transmit Clock Shift, Bit 2 ... 1

Together with bit RCS0 in CCR2, transmit clock shift can be adjusted.

Transmit Channel Capacity Register (XCCR)

Access: write address: ch-A: 32_H
ch-B: 72_H

Value after RESET: 00_H

Note: This register is only used in clock mode 5.



XBC7 ... XBC0 ... Transmit Bit Number Count, Bit 7 ... 0

Defines the number of bits to be transmitted within a time-slot:
Number of bits = XBC + 1 (1 ... 256 bits/time-slot).

Detailed Register Description

Baud Rate Generator Register (BGR)

Access: write address: ch-A: 34_H
ch-B: 74_H



BR7 ... BR0 ...

Baud Rate, bits 7 ... 0

The Baud Rate generator divisor consist of bits BR0-7 from BRG register and bits BR8-9 from the CCR2 register.

The baud rate generator has two modes of operation giving added flexibility.

Standard Mode:

bits BR9–0 give a value N (N = 0 ... 1023) to give a XTAL clock division factor k:

$$k = (N + 1) \times 2$$

Enhanced Mode:

This consists of a 2 stage divider. The first stage is divisor N is determined by bits BR5 ... BR0 (N = 0 ... 63) while the second stage divisor M is determined by bit BR9 ... BR6 (M = 0 ... 15). The first stage divides the clock by integer number up to 63, where the second stage allows further division by powers of 2 (1, 2, 4, 8, 16, 32, 64, 128 ... 32768).

Division by 1 using M = 0 is restricted to frequencies below 10 MHz (to be characterized). The XTAL clock division factor k:

$$k = (N + 1) \times 2^M$$

The Baud Rate generator is typically used to derive clocks for DTE or DCE Asynchronous baud rates with 16- \times oversampling mode. **Appendix A** shows baud rates derived from typical XTAL frequencies using the two modes of the baud rate generator for ASYNC operation with 16- \times oversampling enabled.

Detailed Register Description

Global Interrupt Status Register (GIS)

Access: read address: ch-A: 38_H
ch-B: 78_H

Value after RESET: 00_H

	7							0
GIS	PI	0	0	0	ISA1	ISA0	ISB1	ISB0

This status register points to pending

- channel assigned interrupts:
ISA0 → ISR0, ISA1 → ISR1 on channel A
ISB0 → ISR0, ISB1 → ISR1 on channel B
- universal port interrupts:
PI → PIS.

It is accessible via both channel addresses (38_H or 78_H). As opposed to the 'real' interrupt status registers (ISR0, ISR1, PIS), its contents are not cleared after a read access. The bits in GIS are individually reset when the corresponding interrupt status register has been read.

Interrupt Vector Address (IVA)

Access: write address: ch-A: 38_H
ch-B: 78_H

Value after RESET: 00_H

	7					0
IVA	T7	T3	0	0	0	

Note: Unused bit have to be set to logical '0'.

IVA is accessible via both channel addresses (38_H or 78_H).

T3 ... T7 ...

Interrupt Vector Address

These bits define the value of bits 3 to 7 of the interrupt vector which is sent out on the data bus (D0 ... D7) during the interrupt acknowledge cycle.

Detailed Register Description

Interrupt Port Configuration (IPC)

Access: read/write address: ch-A: 39_H
ch-B: 79_H

Value after RESET: 00_H

	7							0
IPC	VIS	0	0	SLA1	SLA0	CASM	IC1	IC0

Note: Unused bits have to be set to logical '0'.

IPC is accessible via both channel addresses (39_H or 79_H).

VIS ...

Masked Interrupts Visible

- 0 ... Masked interrupt status bits are not visible
- 1 ... Masked interrupt status bits are visible.

SLA1 ... SLA0 ...

Slave Address

Only used in Slave Cascading mode (refer to CASM).

CASM ...

Cascading Mode

- 0 ... Slave Cascading Mode
Pins IE0, IE1 are used as inputs. Interrupt acknowledge is accepted if an interrupt signal has been generated and the values on pins IE0 and IE1 correspond to the programmed values.
- 1 ... Daisy Chaining Mode
Pin IE0 as Interrupt Enable Output and pin IE1 as Interrupt Enable Input are used for building a Daisy Chain. Interrupt acknowledge is accepted if an interrupt signal has been generated and Interrupt Enable Input IE1 is active 'high' during a subsequent INTA cycle. If pin INT goes active, Interrupt Enable Output IE0 is immediately set to 'low'.

IC1 ... IC0 ...

Interrupt Port Configuration

These bits define the function of the interrupt output stage (pin INT):

IOC1	IOC0	Function
X	0	Open drain output
0	1	Push/Pull output, active 'low'
1	1	Push/Pull output, active 'high'

Detailed Register Description

Interrupt Status Register 0 (ISR0)

Access: read address: ch-A: 3A_H
ch-B: 7A_H

Value after RESET: 00_H

	7							0
ISR0	TCD	0	PERR	SCD	PLLA	CDSC	RFO	RPF

All bits are reset when ISR0 is read. Additionally, TCD and RPF are reset when the corresponding interrupt vector is output.

Note: If bit IPC:VIS is set to '1', interrupt statuses in ISR0 may be flagged although they are masked via register IMR0. However, these masked interrupt statuses neither generate an interrupt vector or a signal on INT, nor are they visible in register GIS.

- TCD ... Termination Character Detected**
The termination character (TCR) has been received and a data block is now available in the RFIFO. The actual block length can be determined by reading register RBCL first.
- PERR ... Parity Error**
Only valid if parity check/generation is enabled.
If set, a character with parity error has been received. If enabled via RFDF, parity error information is stored in RFIFO in the status byte pertaining to that character.
- SCD ... SYN Character Detected**
Only valid in Hunt Mode.
This bit is set if a SYN character is found in the received data stream after the HUNT command has been issued. The receiver now is in the synchronous state.
- PLLA ... DPLL Asynchronous**
This bit is only valid when the receive clock is supplied by the DPLL and FM0, FM1 or Manchester data encoding is selected.
It is set when the DPLL has lost synchronization. Reception is disabled (IDLE is inserted) until synchronization has been regained. Additionally, transmission is also interrupted if the transmit clock is derived from the DPLL.
- CDSC ... Carrier Detect Status Change**
Indicates that a state transition has occurred on CD. The actual state of CD can be read from the VSTR register.

Detailed Register Description

RFO ...

Receive FIFO Overflow

This interrupt is generated if RFIFO is full and a further character is received. This interrupt can be used for statistical purposes and indicates that the CPU does not respond quickly enough to an RPF or TCD interrupt.

RPF ...

Receive Pool Full

This bit is set if RFIFO is filled with data (character and optional status information) up to the programmed threshold level.

Note: This interrupt is only generated in Interrupt Mode.

Interrupt Status Register 1 (ISR1)

Access: read address: ch-A: 3B_H ch-B: 7B_H

Value after RESET: 00_H

	7							0
ISR1	0	0	ALLS	XDU	TIN	CSC	XMR	XPR

All bits are reset when ISR1 is read. Additionally, XPR is reset when the corresponding interrupt vector is output.

Note: If bit IPC:VIS is set '1', interrupt statuses in ISR1 may be flagged although they are masked via register IMR1. However, these masked interrupt statuses neither generate an interrupt vector or a signal on INT, nor are visible in register GIS.

ALLS ...

All Sent

This bit is set when the XFIFO is empty and the last character is completely sent out on TxD.

XDU ...

Transmit Data Underrun

A block of data in transmission has been terminated with IDLE, because the XFIFO contains no further data.

Note: Transmitter and XFIFO are reset and deactivated if this condition occurs. They are reactivated not before this interrupt status register has been read. Thus, XDU should not be masked via register IMR1.

Detailed Register Description

Port Interrupt Status Register (PIS)

Access: read address: ch-A: 3D_H
ch-B: 7D_H



PIS is accessible via both channel addresses (3D_H or 7D_H).

Each of the above bits is assigned to the Universal Port pin (P0 ... P7) with the same number. Bit PIS_n is set and an interrupt is generated on INT if

- the corresponding Universal Port pin P_n is defined as input via register PCR and
- the interrupt source is enabled by resetting the corresponding interrupt mask PIM_n in register PIM and
- a state transition has occurred on pin P_n. For definite detection of a real state transition, pulse width should not be shorter than 20 ns.

Note: Bits PIS_n are reset when register PIS is read. Masked interrupts are not normally indicated when PIS is read. Instead, they remain internally stored and pending. A pending interrupt is generated when the corresponding mask bit is reset to 'zero'. However, if bit IPC:VIS is set to '1', interrupt statuses in PIS may be flagged although they are masked via register PIM. These masked interrupt statuses neither generate an interrupt vector or a signal on INT, nor are visible in register GIS.

If more than one consecutive state transition occurs on the same pin before the PIS register is read, only one interrupt request will be generated.

Detailed Register Description

Port Interrupt Mask Register (PIM)

Access: write address: ch-A: 3D_H
ch-B: 7D_H

Value after RESET: FF_H

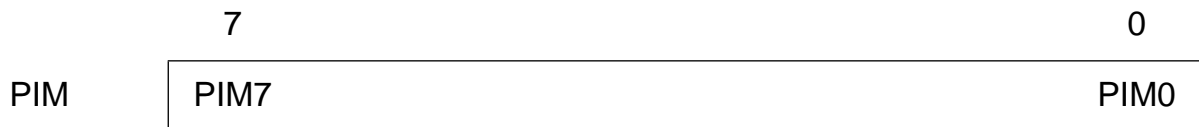

PIM is accessible via both channel addresses (3D_H or 7D_H).

Each of the above bits is assigned to the Universal Port pin (P0 ... P7) and to the bits of register PIS with the same number.

0 ... Interrupt source is enabled.

1 ... Interrupt source is disabled.

A '1' in a bit position of PIM sets the mask active for the interrupt status in PIS. Masked interrupt statuses neither generate an interrupt vector or a signal on INT, nor are they visible in register GIS.

Moreover, they will

- not be displayed in the Interrupt Status Register if bit IPC:VIS is set to '0'
- be displayed in the Interrupt Status Register if bit IPC:VIS is set to '1'.

Refer to description of register PIS.

*Note: After RESET, all interrupt sources are **disabled**.*

Electrical Characteristics

11 Electrical Characteristics

11.1 Absolute Maximum Ratings

Parameter	Symbol	Limit Values		Unit	
		min.	max.		
Ambient temperature under bias	SAB SAF	T_A T_A	0 - 40	70 85	°C °C
Storage temperature		T_{STG}	- 65	150	°C
Supply voltage		V_{DD}	- 0.3	7.0	V
Input voltage		V_I	- 0.3	$V_{DD} + 0.3$ (max. 7.0 V)	V
Output voltage		V_O	- 0.3	$V_{DD} + 0.3$ (max. 7.0 V)	V

Note: Stresses above those listed here may cause permanent damage to the device. Exposure to absolute maximum rating conditions for extended periods may affect device reliability.

11.2 DC Characteristics

SAB: $V_{DD} = 5\text{ V} \pm 5\%$; $V_{SS} = 0\text{ V}$; $T_A = 0\text{ to }70\text{ }^\circ\text{C}$

SAF: $V_{DD} = 5\text{ V} \pm 5\%$; $V_{SS} = 0\text{ V}$; $T_A = -40\text{ to }85\text{ }^\circ\text{C}$

Parameter	Symbol	Limit Values		Unit	Test Condition
		min.	max.		
Input low voltage (not XTAL1, WIDTH)	V_{IL}	- 0.4	0.8	V	
Input high voltage (not XTAL1, WIDTH)	V_{IH}	2.0	$V_{DD} + 0.4$	V	
Input low voltage (WIDTH)	V_{WIL}	- 0.4	1.0	V	
Input high voltage (WIDTH)	V_{WIH}	3.5	$V_{DD} + 0.4$	V	
Input low voltage (ALE)	V_{AIL}	- 0.4	V_{SS}	V	demultiplexed Siemens/Intel mode
	V_{AIL}	- 0.4	0.8	V	multiplexed Siemens/Intel mode
Input low voltage (XTAL1)	V_{XIL}	- 0.4	0.5	V	
Input high voltage (XTAL1)	V_{XIH}	3.5	$V_{DD} + 0.4$	V	

Electrical Characteristics

11.2 DC Characteristics (cont'd)

SAB: $V_{DD} = 5\text{ V} \pm 5\%$; $V_{SS} = 0\text{ V}$; $T_A = 0\text{ to }70\text{ }^\circ\text{C}$

SAF: $V_{DD} = 5\text{ V} \pm 5\%$; $V_{SS} = 0\text{ V}$; $T_A = -40\text{ to }85\text{ }^\circ\text{C}$

Parameter		Symbol	Limit Values		Unit	Test Condition
			min.	max.		
Output low voltage		V_{OL}		0.45	V	$I_{OL} = 7\text{ mA}$ (pins TxD, RxD) $I_{OL} = 2\text{ mA}$ (all others except XTAL2)
Output high voltage		V_{OH}	2.4		V	$I_{OH} = -400\text{ }\mu\text{A}$
Output high voltage		V_{OH}	$V_{DD} - 0.5$		V	$I_{OH} = -100\text{ }\mu\text{A}$
Power supply current	operational	I_{CC}		15	mA	$V_{DD} = 5\text{ V}$ $C_P = 2\text{ MHz}$ Inputs at $0\text{ V}/V_{DD}$, no outputs loads
	power-down			2	mA	
Input leakage current		I_{LI}		10	μA	$0\text{ V} < V_{IN} < V_{DD}$ to 0 V
Output leakage current		I_{LO}			μA	$0\text{ V} < V_{OUT} < V_{DD}$ to 0 V

Note: The listed characteristics are ensured over the operating range of the integrated circuit. Typical characteristics specify mean values expected over the production spread. If not otherwise specified, typical characteristics apply at $T_A = 25\text{ }^\circ\text{C}$ and the given supply voltage.

Electrical Characteristics

11.3 Capacitances

 $V_{DD} = 5\text{ V} \pm 5\%$; $V_{SS} = 0\text{ V}$; $T_A = 25\text{ °C}$

Parameter	Symbol	Limit Values		Unit
		min.	max.	
Input capacitance ¹⁾	C_{IN}	5	10	pF
Output capacitance ¹⁾	C_{OUT}	8	15	pF
I/O capacitance ¹⁾	C_{IO}	10	20	pF

¹⁾ Not tested in production

Electrical Characteristics

11.4 AC Characteristics

SAB: $V_{DD} = 5\text{ V} \pm 5\%$; $V_{SS} = 0\text{ V}$; $T_A = 0\text{ to }70\text{ }^\circ\text{C}$

SAF: $V_{DD} = 5\text{ V} \pm 5\%$; $V_{SS} = 0\text{ V}$; $T_A = -40\text{ to }85\text{ }^\circ\text{C}$

Parameter	Symbol	Limit Values			Unit	Test Condition

Inputs

All inputs except XTAL1 and WIDTH are driven to	V_{IH}		2.4		V	for logical '1'
	V_{IL}		0.4		V	for logical '0'
XTAL1 and WIDTH (CMOS inputs) are driven to	V_{IH}		4.0		V	for logical '1'
	V_{IL}		0.4		V	for logical '0'

Timing Measurements

Measurements except for XTAL2 are driven to	V_H		2.0		V	for logical '1'
	V_L		0.8		V	for logical '0'
Measurements for XTAL2 are driven to	V_H		3.5		V	for logical '1'
	V_L		1.0		V	for logical '0'

Note: The listed characteristics are ensured over the operating range of the integrated circuit. Typical characteristics specify mean values expected over the production spread. If not otherwise specified, typical characteristics apply at $T_A = 25\text{ }^\circ\text{C}$ and the given supply voltage.

The AC testing input/output waveforms are shown below:

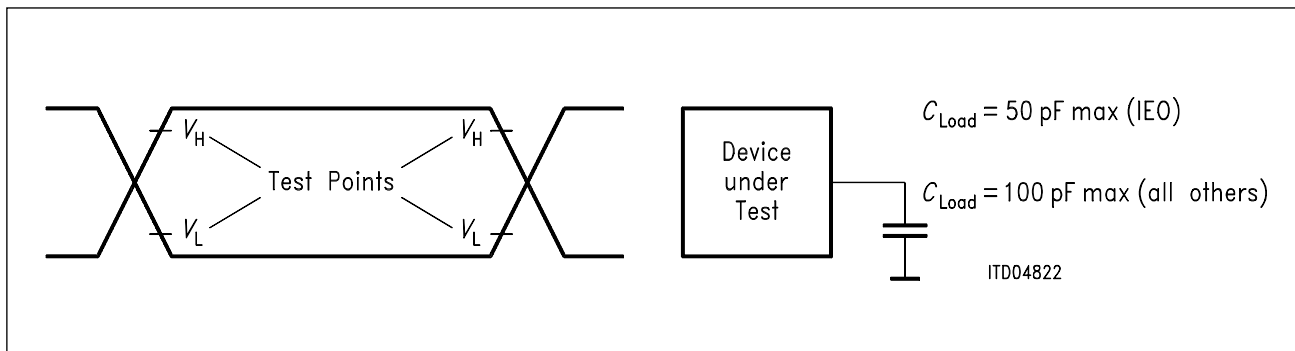

Figure 53
Input/Output Waveform for AC Tests

11.4.1 Microprocessor Interface

11.4.1.1 Siemens/Intel Bus Interface Mode

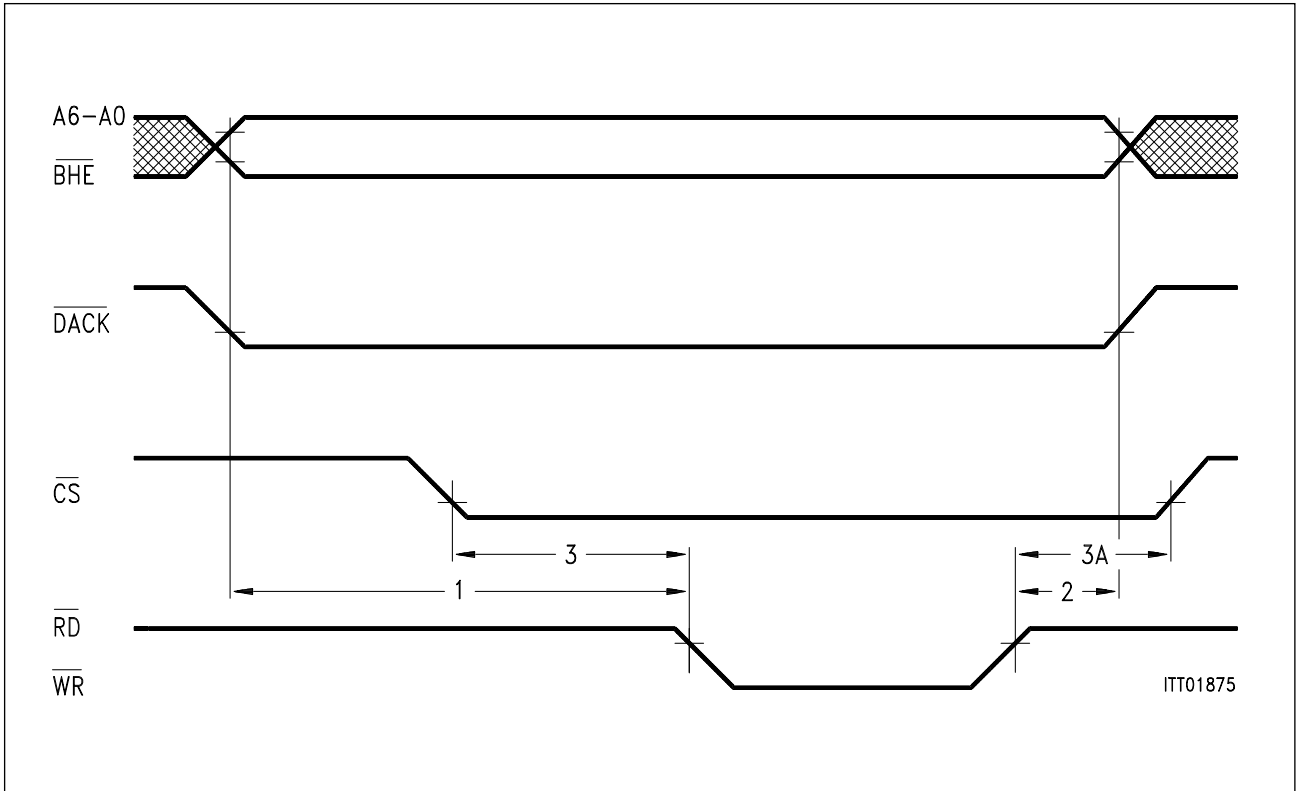

Figure 54
Siemens/Intel Non-Multiplexed Address Timing

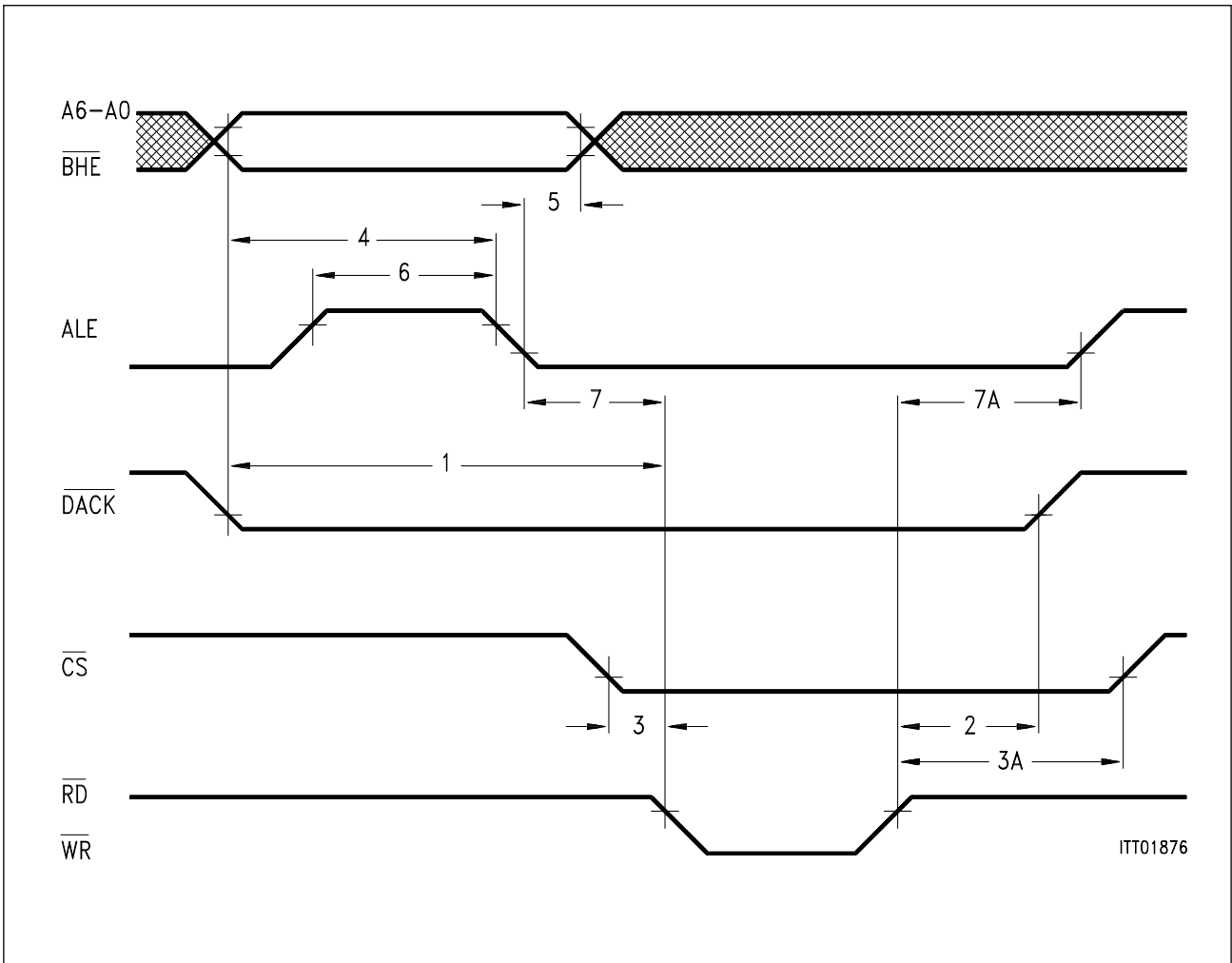

Figure 55
Siemens/Intel Multiplexed Address Timing

Electrical Characteristics

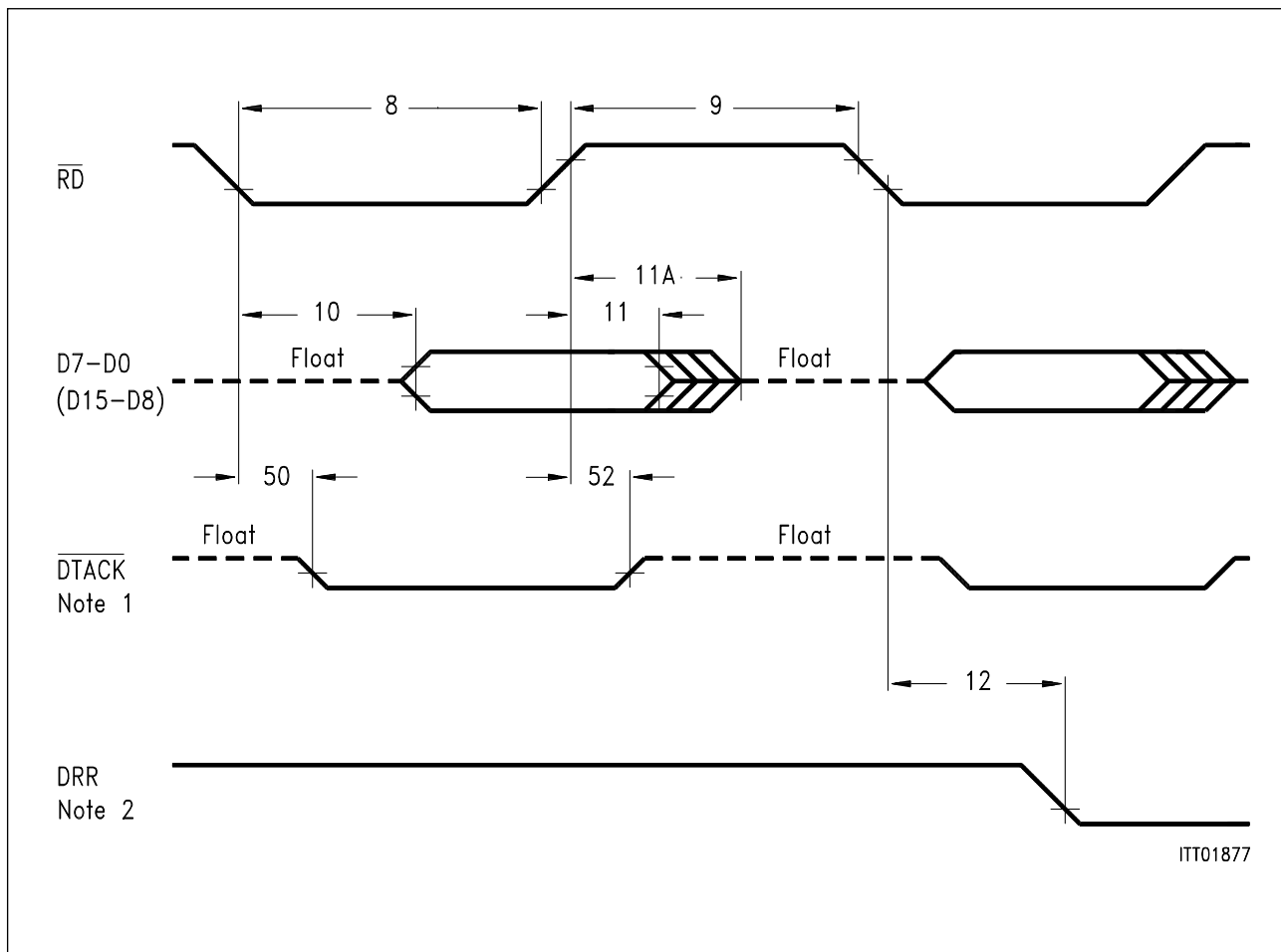

Figure 56
Siemens/Intel Read Cycle Timing

Note 1: Function of DTACK is described logically as:

$$\overline{DTACK} = (\overline{CS} \times \overline{DACKA} \times \overline{DACKB} + \overline{RD} \times \overline{WR}) \times \overline{INTAi}$$
INTAi is an internally generated signal.

Note 2: DRR is reset with the falling edge of \overline{RD} during the last read access to RFIFO.

Electrical Characteristics

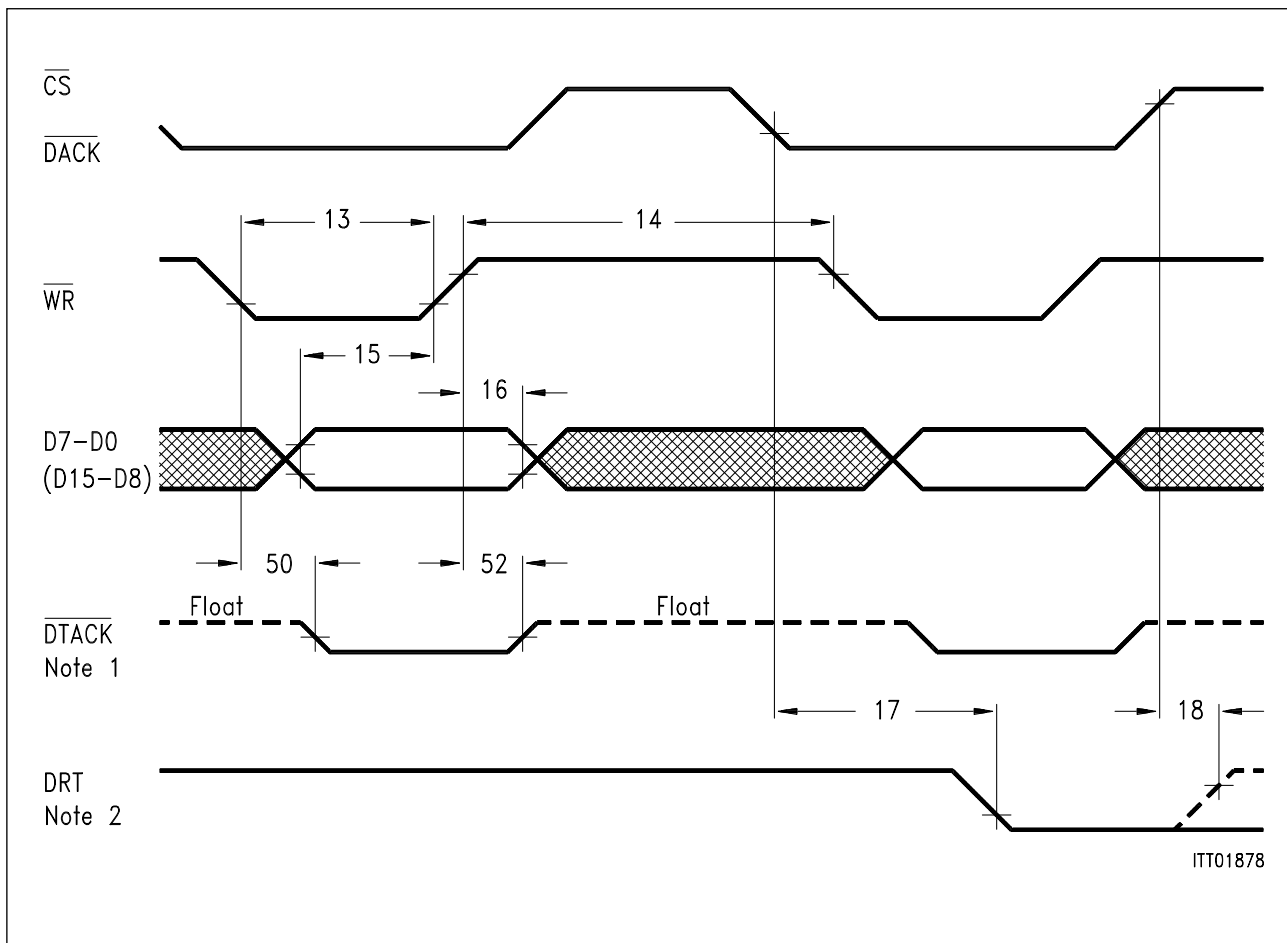

ITT01878

Figure 57
Siemens/Intel Write Cycle Timing

Note 1: Function of \overline{DTACK} is described logically as:

$$\overline{DTACK} = (\overline{CS} \times \overline{DACKA} \times \overline{DACKB} + \overline{RD} \times \overline{WR}) \times \overline{INTAi}$$
INTAi is an internally generated signal.

Note 2: *DRT* is reset with the falling edge of \overline{CS} or \overline{DACK} if the last write access to *XFIFO* is expected. However, *DRT* will be activated again in the case of an access to any other register or *FIFO*.

Electrical Characteristics

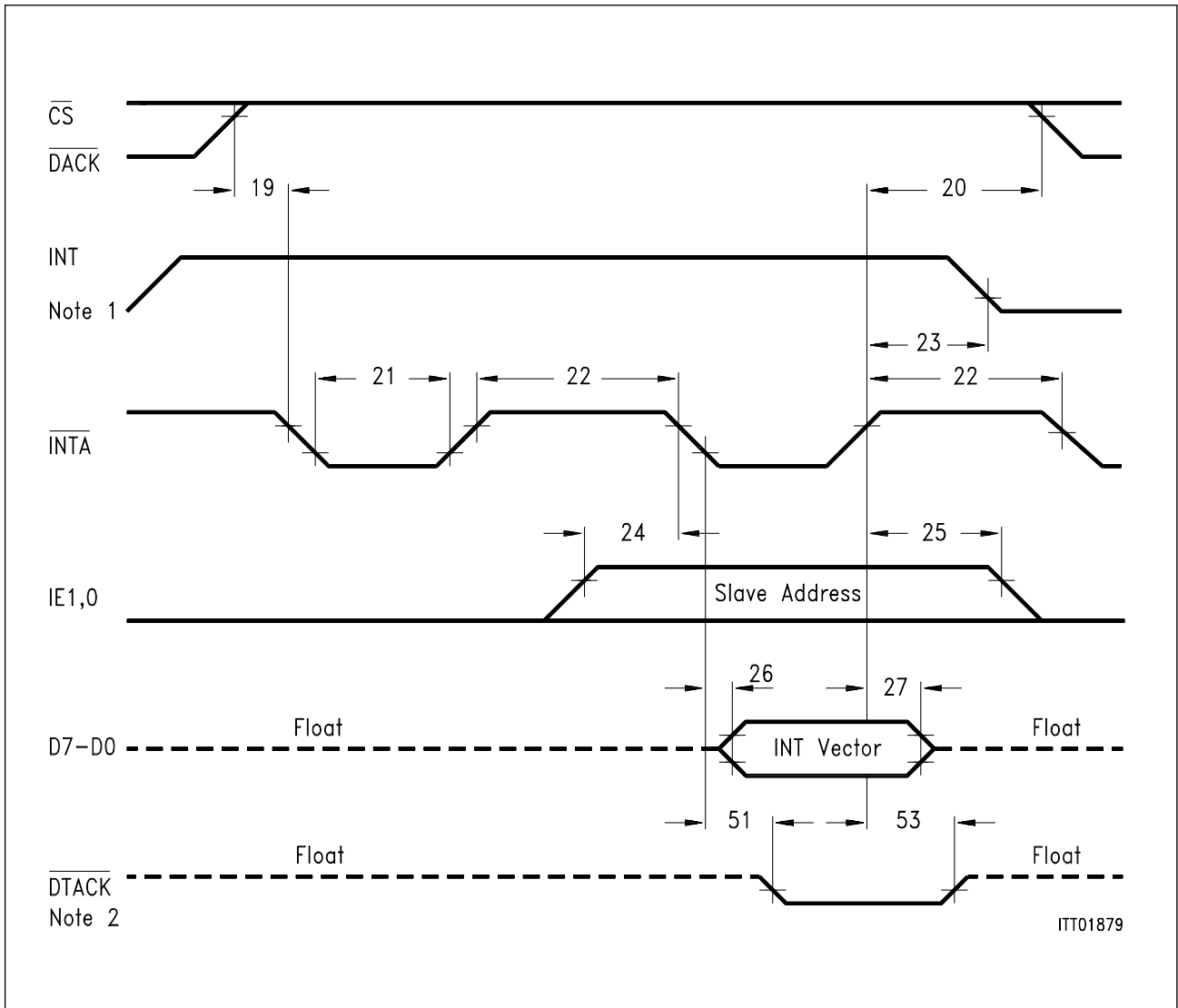

Figure 58
Siemens/Intel Interrupt Timing (slave mode)

*Note 1: Timing valid for active-high push-pull signal, timing for active-low push-pull signal is the same.
 In case of an open drain output, reset time (T23) depends on external devices.*

*Note 2: Function of DTACK is described logically as:
 $DTACK = (\overline{CS} \times \overline{DACKA} \times \overline{DACKB} + RD \times WR) \times \overline{INTAi}$.
 $INTAi$ is an internally generated signal. It is generated if the interrupt acknowledge cycle is considered valid.*

Electrical Characteristics

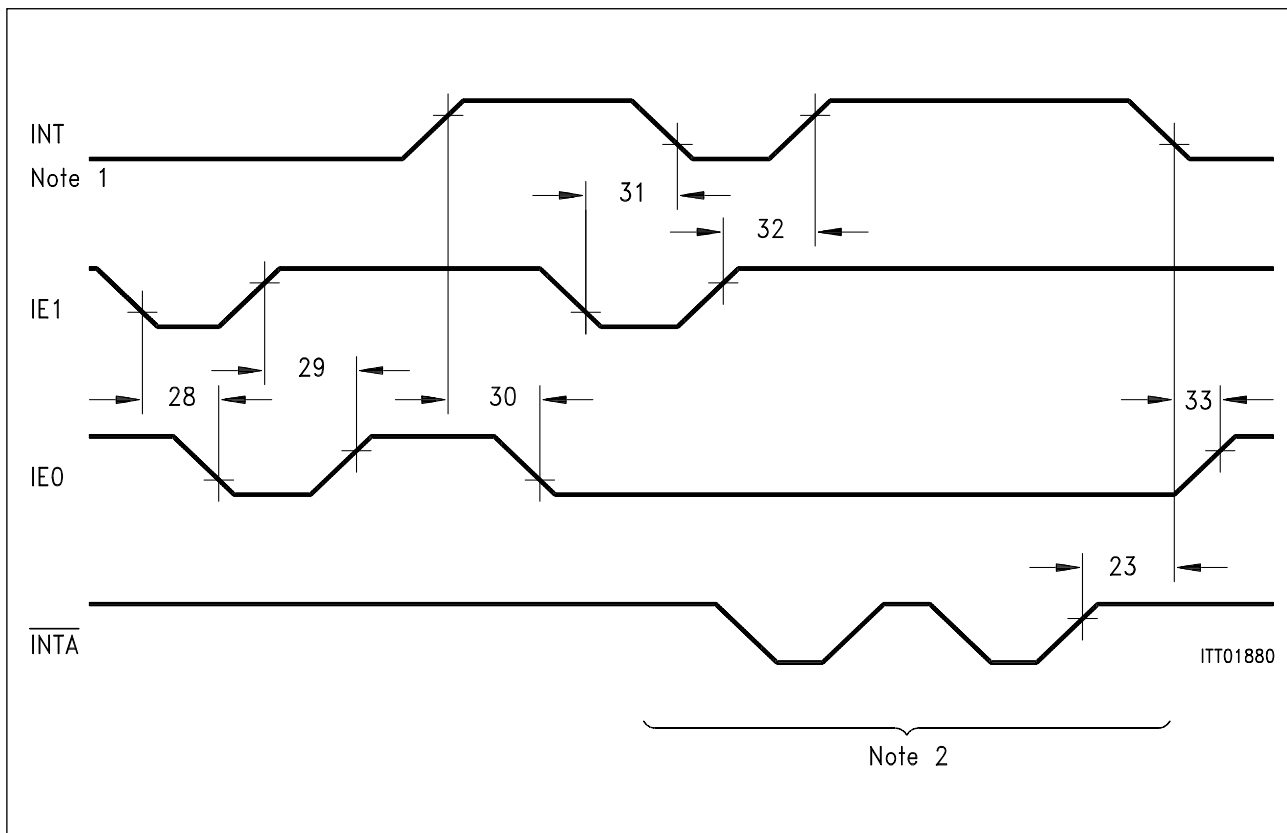

Figure 59
Siemens/Intel Interrupt Timing (Daisy Chaining)

Note 1: Timing valid for active-high push-pull signal. Timing for active-low push-pull signal is the same.

In case of an open-drain output, reset times (T_{23} , T_{31}) depend on external devices.

Note 2: Timing for \overline{CS} , \overline{DACK} , \overline{INT} , \overline{INTA} and $D7 \dots D0$ is similar to slave mode.

Electrical Characteristics

Siemens/Intel Bus Interface Timing and Interrupt Timing

No.	Parameter	Symbol	Limit Values		Unit
			min.	max.	
1	Address, $\overline{\text{BHE}}$, $\overline{\text{DACK}}$ setup time	$t_{\text{su(A)}}$	5		ns
2	Address, $\overline{\text{BHE}}$, $\overline{\text{DACK}}$ hold time	$t_{\text{h(A)}}$	10		ns
3	$\overline{\text{CS}}$ setup time	$t_{\text{su(A)}}$	0		ns
3A	$\overline{\text{CS}}$ hold time	$t_{\text{h(A)}}$	0		ns
4	Address, $\overline{\text{BHE}}$ stable before ALE inactive	$t_{\text{su(A-ALE)}}$	20		ns
5	Address, $\overline{\text{BHE}}$ hold after ALE inactive	$t_{\text{su(ALE-A)}}$	10		ns
6	ALE pulse width	$t_{\text{w(ALE)}}$	30		ns
7	Address latch setup time before command active	$t_{\text{su(ALE)}}$	0		ns
7A	ALE to command inactive delay	$t_{\text{rec(ALE)}}$	20		ns
8	$\overline{\text{RD}}$ pulse width	$t_{\text{w(R)}}$	70		ns
9	$\overline{\text{RD}}$ control interval	$t_{\text{rec(R)}}$	50		ns
10	Data valid after $\overline{\text{RD}}$ active	$t_{\text{a(R)}}$		65	ns
11	Data hold after $\overline{\text{RD}}$ inactive	$t_{\text{v(R)}}$	10		ns
11A	$\overline{\text{RD}}$ inactive to data bus tristate ¹⁾	$t_{\text{dis(R)}}$		40	ns
12	DRR low after $\overline{\text{RD}}$ active	$t_{\text{p(DRR)}}$		45	ns
13	$\overline{\text{WR}}$ pulse width	$t_{\text{w(W)}}$	35		ns
14	$\overline{\text{WR}}$ control interval	$t_{\text{rec(W)}}$	35		ns
15	Data stable before $\overline{\text{WR}}$ inactive	$t_{\text{su(D)}}$	30		ns
16	Data hold after $\overline{\text{WR}}$ inactive	$t_{\text{h(D)}}$	5		ns
17	DRT low after $\overline{\text{CS}}$, $\overline{\text{DACK}}$ active	$t_{\text{dis(DRT)}}$		30	ns
18	DRT return to one after $\overline{\text{CS}}$, $\overline{\text{DACK}}$ inactive	$t_{\text{p(DRT)}}$		30	ns
19	$\overline{\text{CS}}$, $\overline{\text{DACK}}$ inactive setup ($\overline{\text{INTA}}$ cycle)	$t_{\text{dis(S-INT)}}$	0		ns
20	$\overline{\text{CS}}$, $\overline{\text{DACK}}$ inactive hold ($\overline{\text{INTA}}$ cycle)	$t_{\text{INTA-S}}$	0		ns
21	$\overline{\text{INTA}}$ pulse width	$t_{\text{w(INTA)}}$	70		ns
22	$\overline{\text{INTA}}$ control interval	$t_{\text{rec(INTA)}}$	30		ns
23	INT reset after last $\overline{\text{INTA}}$ inactive	$t_{\text{INTA-INT}}$		30	ns
24	Slave address (IE0, IE1) setup time	$t_{\text{su(IE)}}$	10		ns
25	Slave address (IE0, IE1) hold time	$t_{\text{h(IE)}}$	5		ns

¹⁾ Not tested in production

Electrical Characteristics

Siemens/Intel Bus Interface Timing and Interrupt Timing (cont'd)

No.	Parameter	Symbol	Limit Values		Unit
			min.	max.	
26	Interrupt vector (D7 ... D0) valid after $\overline{\text{INTA}}$ active	$t_{a(\text{VEC})}$		50	ns
27	Interrupt vector (D7 ... D0) hold after $\overline{\text{INTA}}$ inactive	$t_{v(\text{VEC})}$	10	40	ns
28	IE0 low after IE1 low	$t_{\text{IE1L-IE0L}}$		20	ns
29	IE0 high after IE1 high	$t_{\text{IE1H-IE0H}}$		20	ns
30	IE0 low after INT active	$t_{\text{INTV-IE0L}}$		10	ns
31	INT inactive after IE1 low	$t_{\text{dis}(\text{INT})}$		25	ns
32	INT reactivated after IE1 high	$t_{\text{IE1H-INTV}}$		25	ns
33	IE0 high after INT reset	$t_{\text{INTV-IE0H}}$		30	ns
50	$\overline{\text{DTACK}}$ active after command active	$t_{p(\text{DTK})}$		30	ns
51	$\overline{\text{DTACK}}$ active after $\overline{\text{INTA}}$ active	$t_{p(\text{INT-DTK})}$		35	ns
28	$\overline{\text{DTACK}}$ hold after command inactive	$t_{v(\text{DTK})}$	10	40	ns
29	$\overline{\text{DTACK}}$ hold after $\overline{\text{INTA}}$ inactive	$t_{v(\text{INT-DTK})}$	10	40	ns

Note: $t_{27 \text{ max}}$ not tested in production

11.4.1.2 Motorola Bus Interface Mode

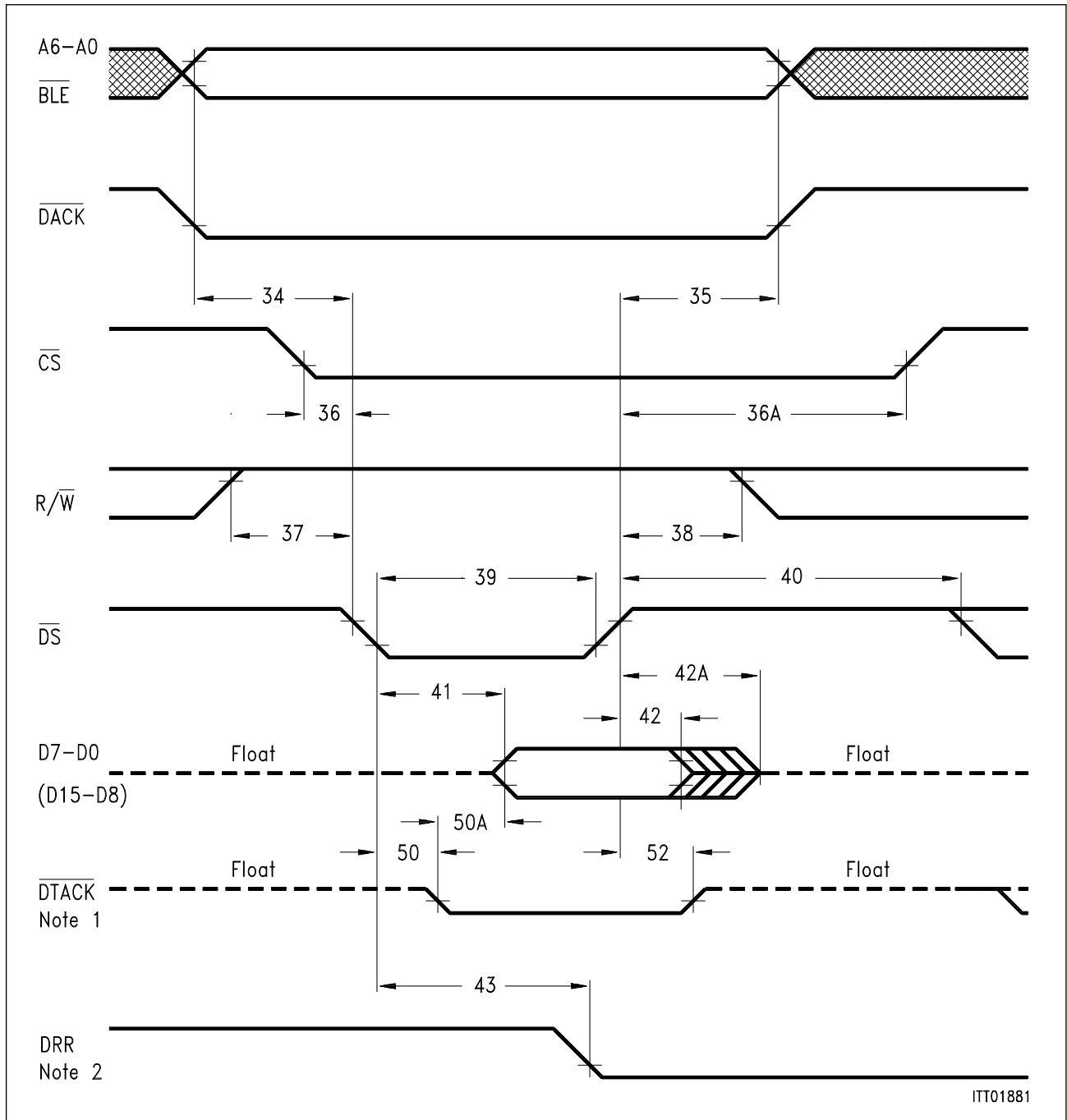

ITT01881

Figure 60
Motorola Read Cycle Timing

*Note 1: Function of \overline{DTACK} is described logically as:
 $\overline{DTACK} = \overline{CS} \times \overline{DACKA} \times \overline{DACKB} \times \overline{INTAi} + \overline{DS} \times \overline{R/W}$ i.e. in accordance with common specifications of Motorola read accesses the timing of \overline{DTACK} is normally determined by \overline{DS} .*

Note 2: DRR is reset with the falling edge of \overline{DS} during the last read access to RFIFO.

Electrical Characteristics

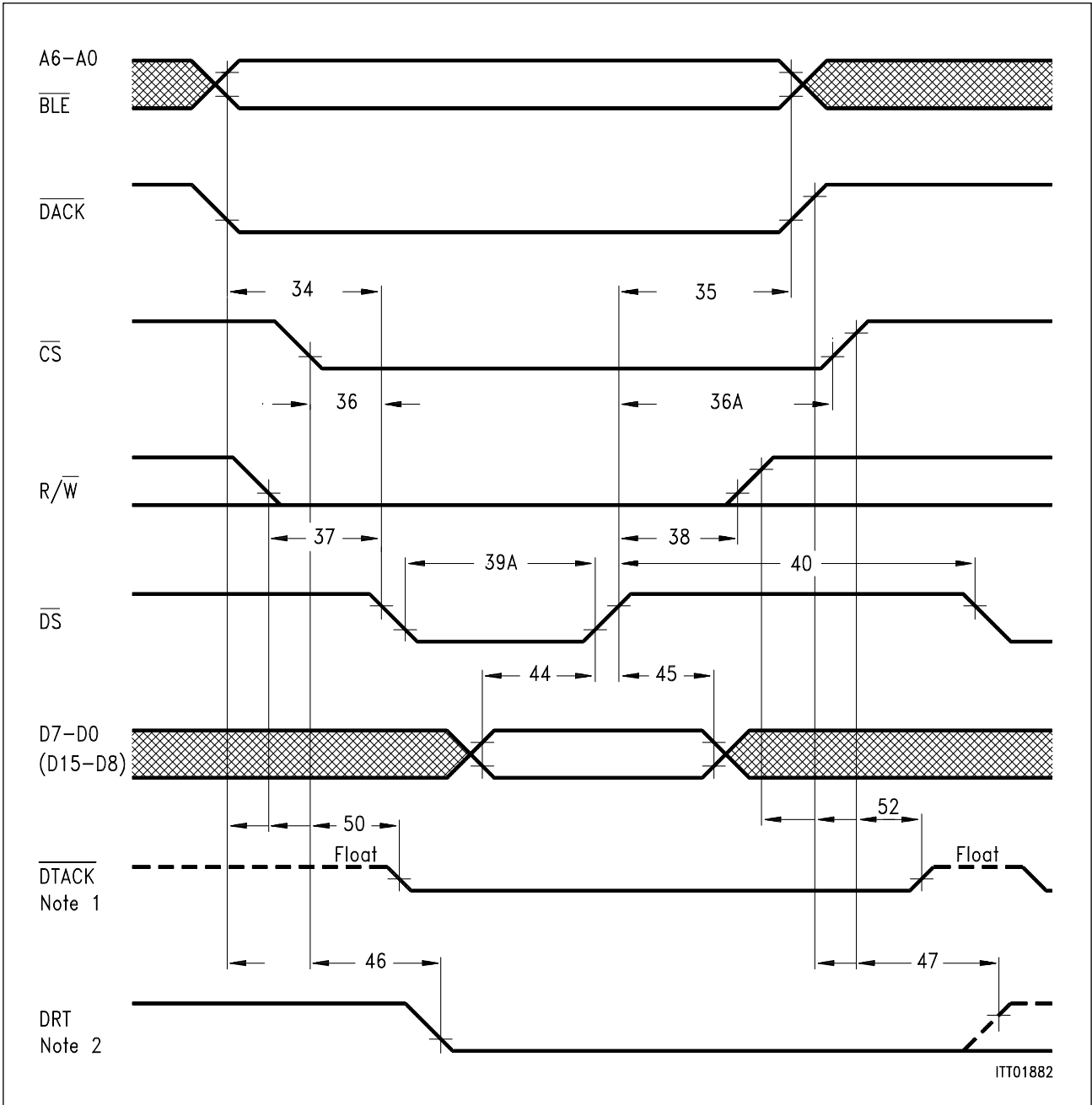

Figure 61
Motorola Write Cycle Timing

Note 1: Function of \overline{DTACK} is described logically as:
 $\overline{DTACK} = \overline{CS} \times \overline{DACKA} \times \overline{DACKB} \times \overline{INTAi} + \overline{DS} \times \overline{R/W}$ i.e. in accordance with common specifications of Motorola accesses.
 \overline{DTACK} goes active if either \overline{CS} or \overline{DACKx} is active and $\overline{R/W}$ goes low.
 \overline{DTACK} goes inactive if \overline{CS} and \overline{DACKx} are inactive or write $\overline{R/W}$ goes high.
 To guarantee correct function in the case of write bursts signals \overline{CS} and \overline{DACKx} have to be inactive after each write access (e.g. by deriving them from the Address Strobe \overline{AS}).

Electrical Characteristics

Note 2: DRT is reset with the falling edge of \overline{CS} or \overline{DACK} if the last write access to XFIFO is expected. However, DRT will be activated again in the case of an access to any other register or FIFO.

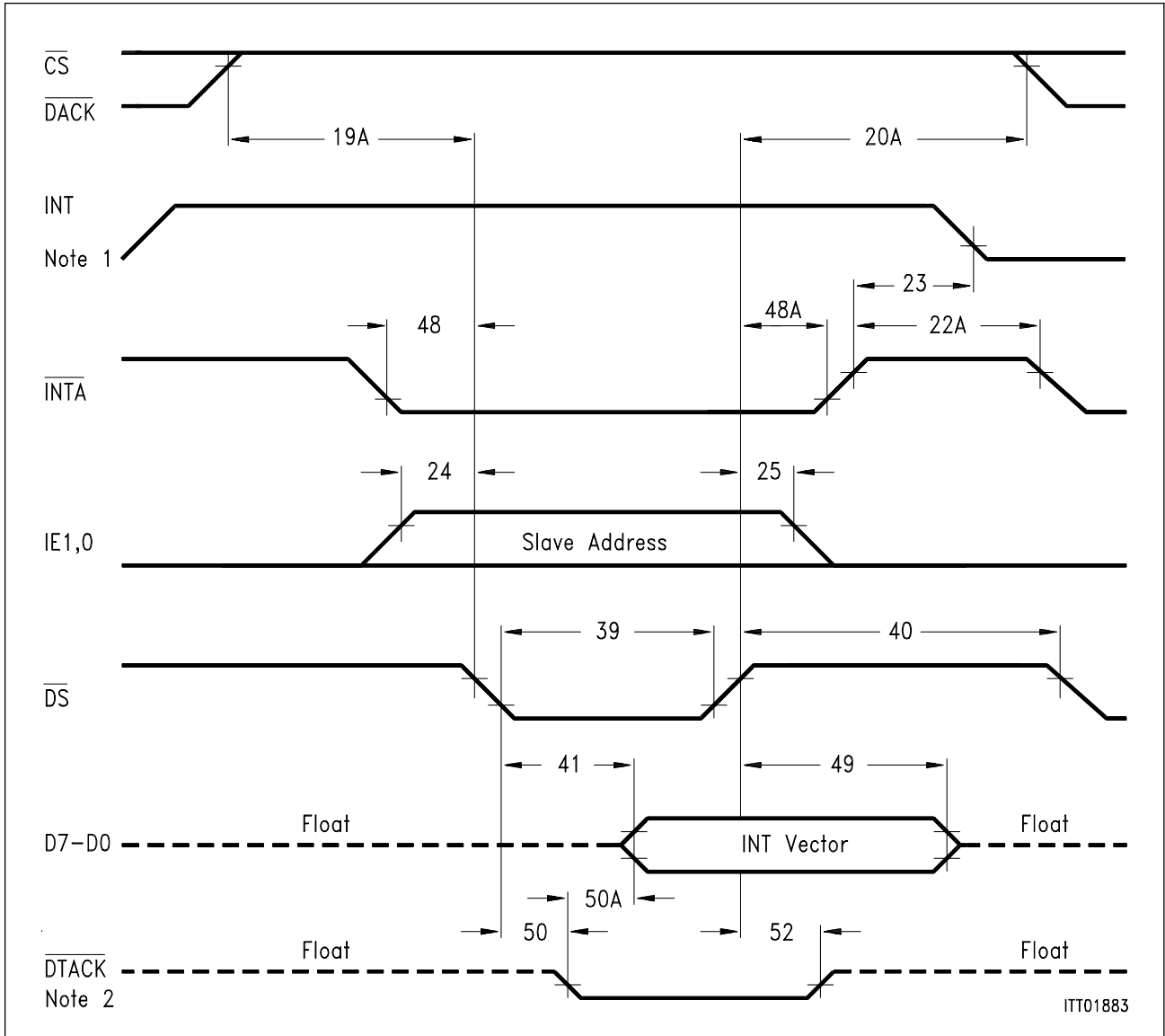

Figure 62
Motorola Interrupt Timing (slave mode)

Note 1: Timing valid for active-high push-pull signal. Timing for active-low push-pull signal is the same.
In the case of an open-drain output, reset times (T_{23} , T_{31}) depend on external devices.

Note 2: Function of \overline{DTACK} is described logically as:
$$\overline{DTACK} = \overline{CS} \times \overline{DACKA} \times \overline{DACKB} \times \overline{INTAi} + \overline{DS} \times R/W .$$

 \overline{INTAi} is an internal signal. It is generated if the interrupt acknowledge cycle is considered valid.

Electrical Characteristics

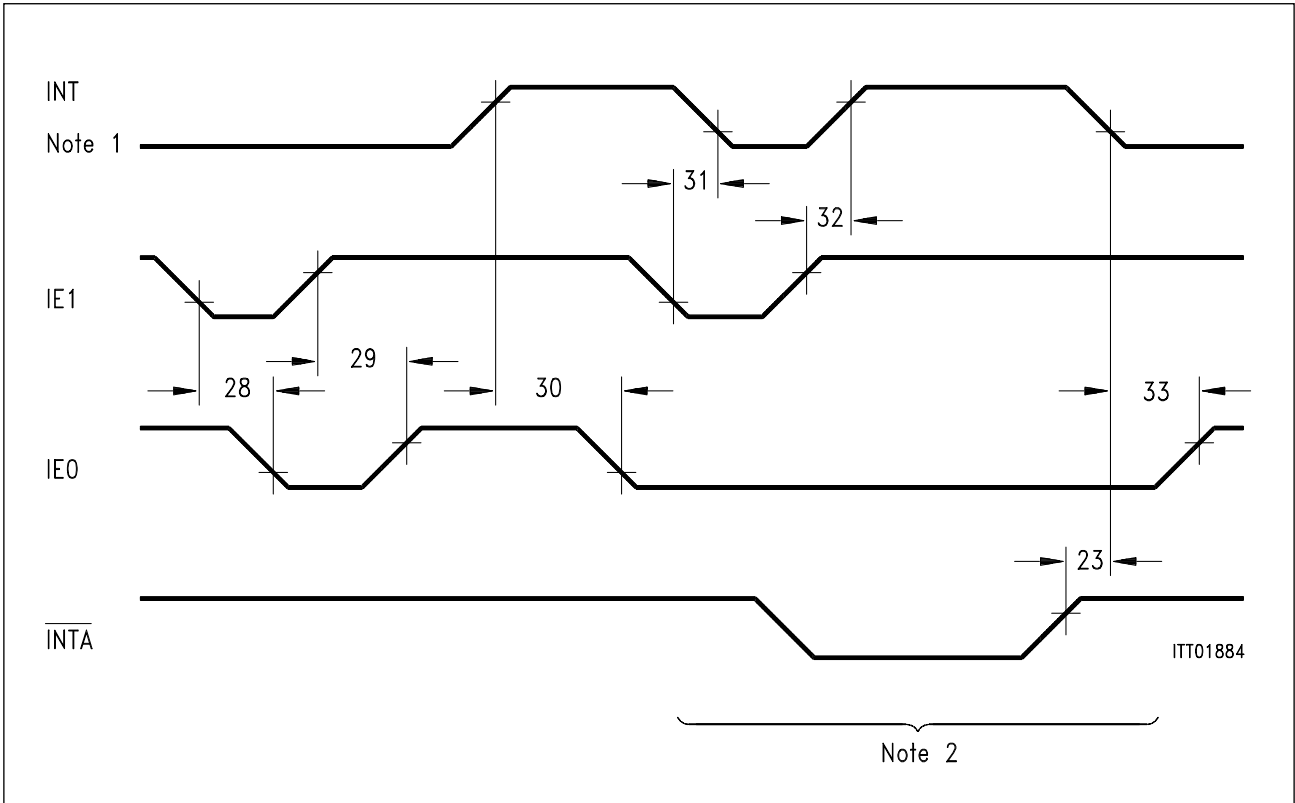

Figure 63
Motorola Interrupt Timing (Daisy Chaining)

Note 1: Timing valid for active-high push-pull signal. Timing for active-low push-pull signal is the same.

In the case of an open-drain output, reset times (T23, T31) depend on external devices.

Note 2: Timing for \overline{CS} , \overline{DACK} , \overline{INT} , \overline{INTA} , \overline{DS} and D7 ... D0 is similar to slave mode.

Motorola Bus Interface Timing and Interrupt Timing

No.	Parameter	Symbol	Limit Values		Unit
			min.	max.	
34	Address, \overline{BLE} , \overline{DACK} setup time before \overline{DS} active	$t_{su(A)}$	5		ns
35	Address, \overline{BLE} , \overline{DACK} hold after \overline{DS} inactive	$t_{h(A)}$	0		ns
36	\overline{CS} active before \overline{DS} active	$t_{su(A)}$	0		ns
36A	\overline{CS} hold after \overline{DS} inactive	$t_{h(A)}$	0		ns
37	R/ \overline{W} stable before \overline{DS} active	$t_{su(RW)}$	5		ns
38	R/ \overline{W} hold after \overline{DS} inactive	$t_{h(RW)}$	0		ns
39	\overline{DS} pulse width (read access)	$t_{w(DS)R}$	70		ns

Electrical Characteristics

Motorola Bus Interface Timing and Interrupt Timing (cont'd)

No.	Parameter	Symbol	Limit Values		Unit
			min.	max.	
39A	\overline{DS} pulse width (write access)	$t_{w(DS)W}$	35		ns
40	\overline{DS} control interval	$t_{rec(DS)}$	50		ns
41	Data valid after \overline{DS} active (read access)	$t_{a(DS)}$		65	ns
42	Data hold after \overline{DS} inactive (read access)	$t_{v(DS)}$	10		ns
42A	\overline{DS} inactive to databus tristate ¹⁾ (read access)	$t_{dis(DS)}$		40	ns
43	DRR low after \overline{DS} active	$t_{p(DRR)}$		45	ns
44	Data stable before \overline{DS} inactive (write access)	$t_{su(D)}$	30		ns
45	Data hold after \overline{DS} inactive (write access)	$t_{h(D)}$	5		ns
46	DRT low after \overline{DS} or \overline{DACK} active	$t_{dis(DRT)}$		30	ns
47	DRT return to one after \overline{CS} or \overline{DACK} inactive	$t_{p(DRT)}$		30	ns
19A	\overline{CS} , \overline{DACK} inactive setup before \overline{DS} (\overline{INTA} cycle)	$t_{dis(S-INTA)}$	20		ns
20A	\overline{CS} , \overline{DACK} inactive hold after \overline{DS} (\overline{INTA} cycle)	$t_{h(INTA-S)}$	20		ns
22A	\overline{INTA} control interval	$t_{rec(INTA)}$	30		ns
23	INT reset after last \overline{INTA} inactive	$t_{INTA-INT}$		30	ns
24	Slave address (IE0, IE1) setup time	$t_{su(IE)}$	10		ns
25	Slave address (IE0, IE1) hold time	$t_{h(IE)}$	5		ns
28	IE0 low after IE1 low	$t_{IE1L-IE0L}$		20	ns
29	IE0 high after IE1 high	$t_{IE1H-IE0H}$		20	ns
30	IE0 low after INT active	$t_{INTV-IE0L}$		10	ns
31	INT inactive after IE1 low	$t_{dis(INT)}$		25	ns
32	INT reactivated after IE1 high	$t_{IE1H-INTV}$		25	ns
33	IE0 high after INT reset	$t_{INT-IE0H}$		20	ns
48	\overline{INTA} setup time	$t_{su(INTA)}$	0		ns
48A	\overline{INTA} hold time	$t_{h(INTA)}$	0		ns
49	Interrupt vector hold after \overline{DS} or \overline{INTA} inactive	$t_{v(VEC)}$	10	40 ¹⁾	ns
50	\overline{DTACK} active delay	$t_{p(DTK)}$		30	ns
50A	\overline{DTACK} active to data valid (read cycle)	t_{DTK-D}		30 ¹⁾	ns
52	\overline{DTACK} hold after command inactive	$t_{v(DTK)}$	10	40 ¹⁾	ns

¹⁾ Not tested in production

11.4.2 Parallel Port Timing

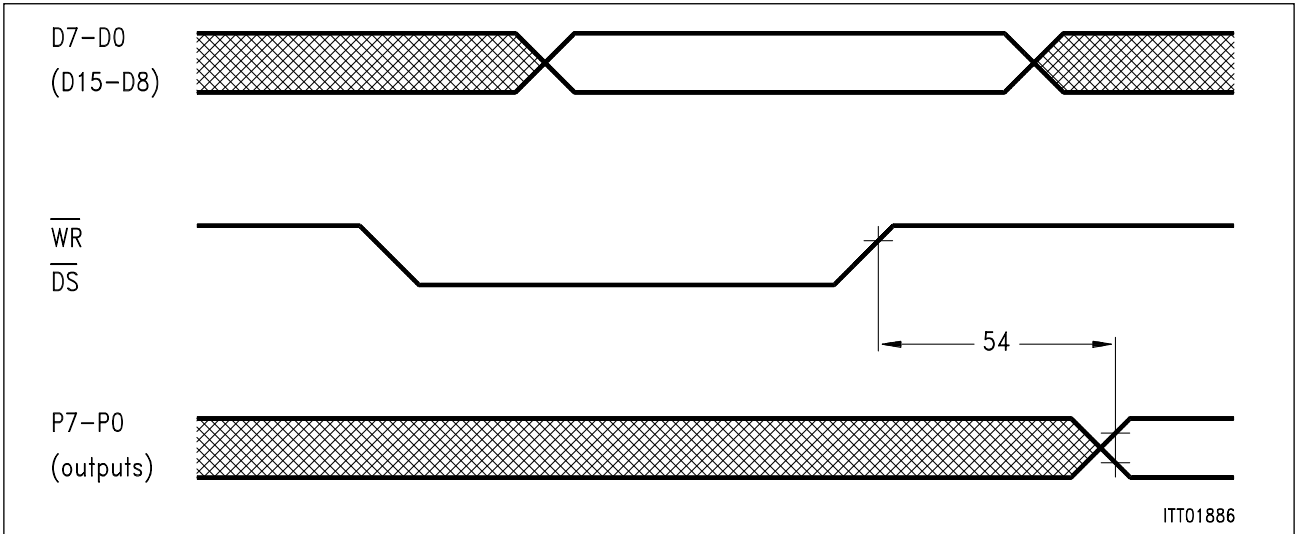

Figure 64
Parallel Port Write Access

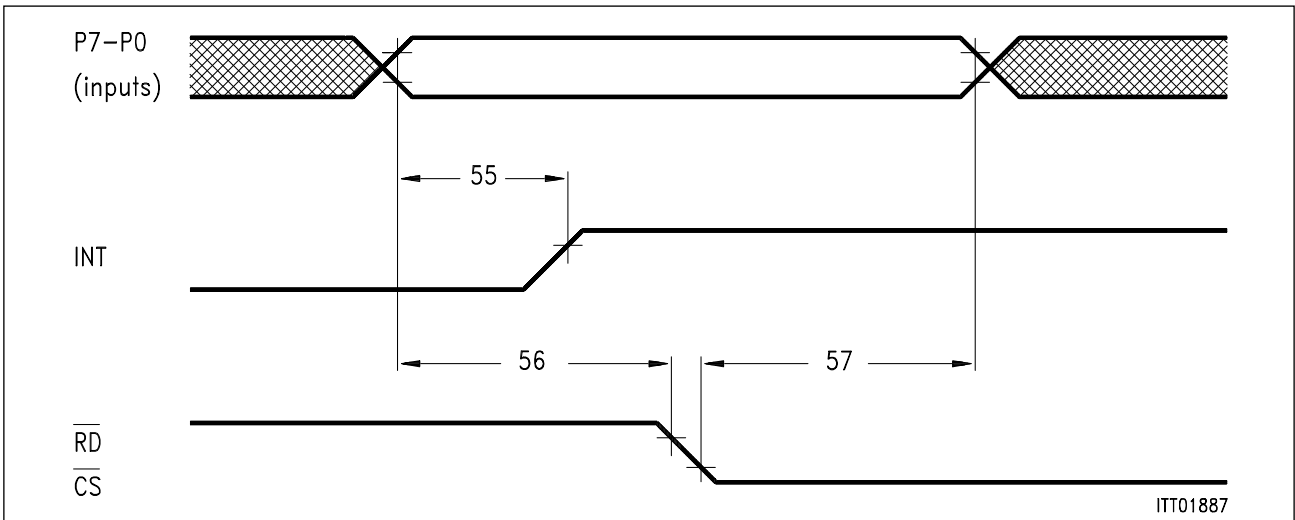

Figure 65
Parallel Port Read Access

Parallel Port Timing

No.	Parameter	Symbol	Limit Values		Unit
			min.	max.	
54	Port output data valid after \overline{WR} , \overline{DS} inactive	t_{QV}		60	ns
55	Port input data change to INT active delay	$t_{p(PV-INT)}$		50	ns
56	Port input data stable before \overline{RD} , \overline{DS} active	$t_{su(P)}$	20		ns
57	Port input data hold after \overline{RD} , \overline{DS} active	$t_{h(P)}$	30		ns

11.4.3 Serial Interface

11.4.3.1 Clock Input Timing

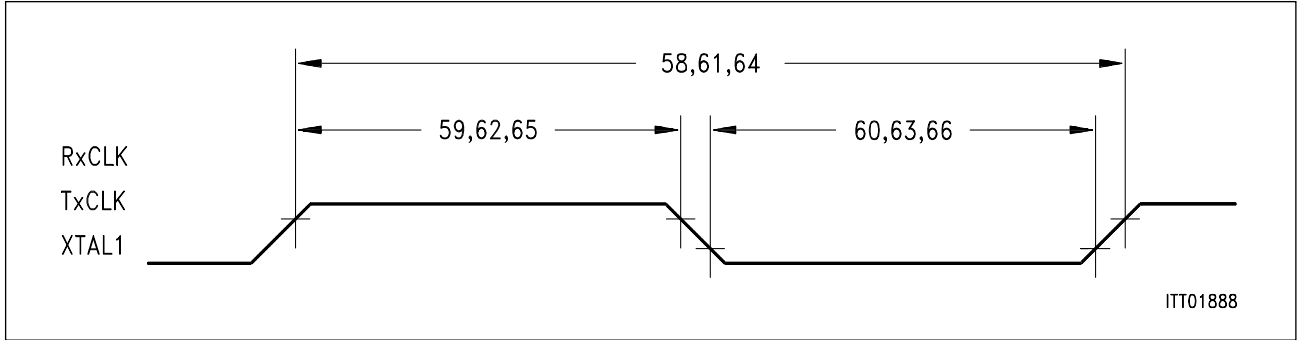

Figure 66

Clock Timing

No.	Parameter	Symbol	Limit Values				Unit
			N		N-10		
			min.	max.	min.	max.	
58	RxCLK clock period	$t_{c(RxC)}$	480 ¹⁾ 30 ³⁾		100 ¹⁾ 30 ³⁾		ns ns
59	RxCLK high time	$t_{w(RxCH)}$	150 ¹⁾ 13 ³⁾		45 ¹⁾ 13 ³⁾		ns ns
60	RxCLK low time	$t_{w(RxCL)}$	150 ¹⁾ 13 ³⁾		45 ¹⁾ 13 ³⁾		ns ns
61	TxCLK clock period	$t_{c(TxC)}$	480		100		ns
62	TxCLK high time	$t_{w(TxCH)}$	150		45		ns
63	TxCLK low time	$t_{w(TxCL)}$	150		45		ns
64	XTAL1 clock period	$t_{c(XTAL1)}$	480 ²⁾ 30 ³⁾		50 ²⁾ 30 ³⁾		ns ns
65	XTAL1 high time	$t_{w(XTAL1H)}$	150 ²⁾ 13 ³⁾		23 ²⁾ 13 ³⁾		ns ns
66	XTAL1 low time	$t_{w(XTAL1L)}$	150 ²⁾ 13 ³⁾		23 ²⁾ 13 ³⁾		ns ns

1) Externally clocked: clock mode 0, 1 except ASYNC, BCR = 16.

2) Externally clocked: clock mode 4 except ASYNC, BCR = 16;
Master clock mode generally.

3) Internally clocked: HDLC, BISYNC: DPLL + baud rate generator used; ASYNC all other clocking modes.

11.4.3.2 Receive Cycle Timing

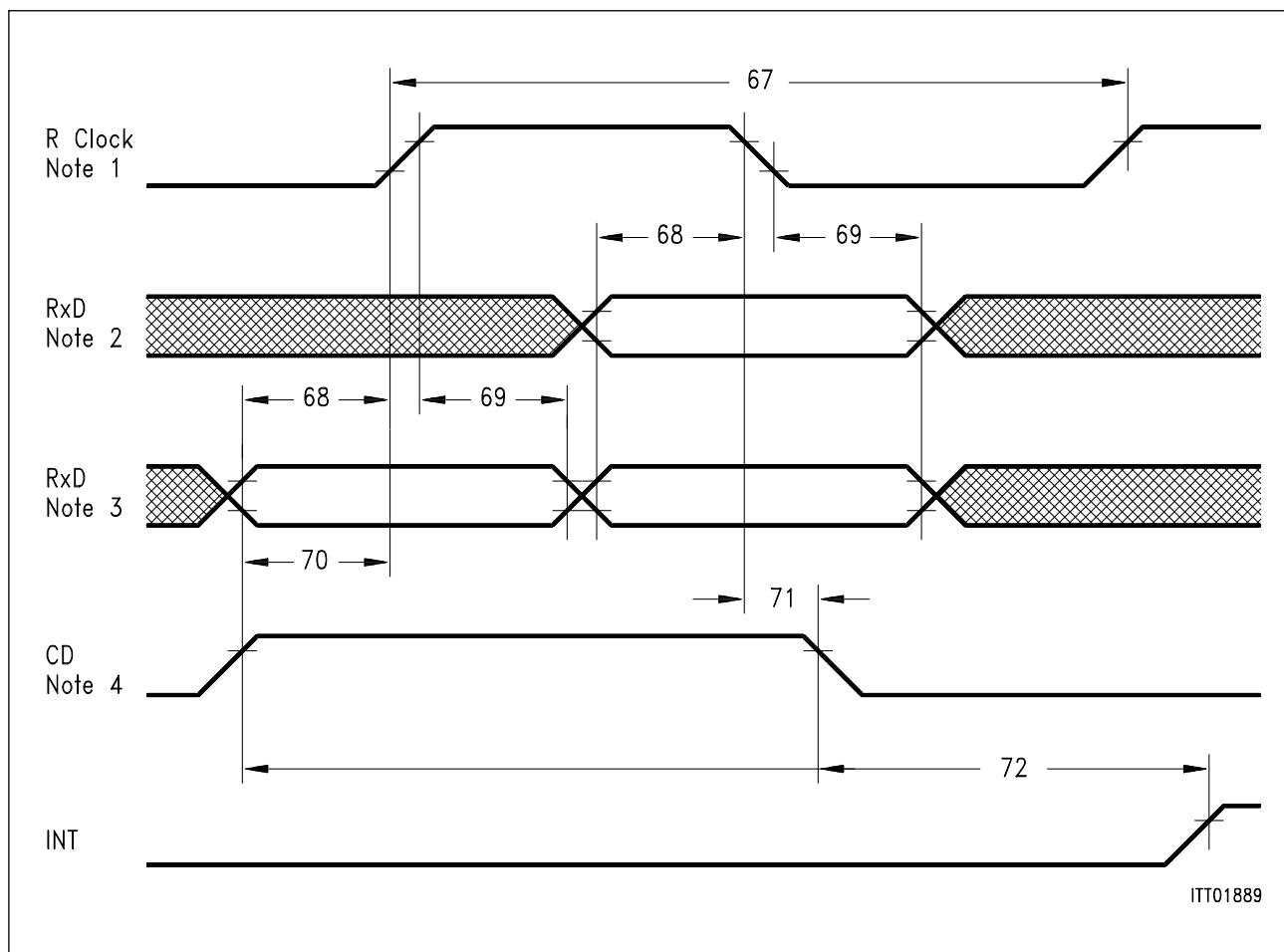

Figure 67
Receive Cycle Timing

Note 1: Whichever supplies the clock: externally clocked by RxCLK or XTAL1, or, internally derived from DPLL, BRG or BCR divider (refer to **table 5**).

Note 2: NRZ, NRZI and Manchester coding.

Note 3: FM0 and FM1 coding.

Note 4: Carrier detect auto start enabled (not for clock modes 1, 5).

Electrical Characteristics

Receive Cycle Timing

No.	Parameter	Symbol	Limit Values				Unit
			N		N-10		
			min.	max.	min.	max.	
	Receive data rate	ext. clocked (except ASYNC, BCR = 16)		2		10	Mbit/s
		int. clocked (HDLC, BISYNC: only DPLL)		2		2	Mbit/s
		int. clocked (all other internal modes)		2		2	Mbit/s
67	Clock period	ext. clocked (except ASYNC, BCR = 16)	$t_{c(RC)}$	480		100	ns
		int. clocked (HDLC, BISYNC: only DPLL)		480		480	ns
		int. clocked (all other internal modes)		480		480	ns
68	Receive data setup		$t_{su(RxD)}$	10		10	ns
69	Receive data hold		$t_{h(RxD)}$	30		30	ns
70	Carrier detect setup		$t_{su(CD)}$	50		50	ns
71	Carrier detect hold		$t_{h(CD)}$	30		30	ns
72	CD status change to INT delay		t_{CD-INT}		T73 + 60	T73 + 60	ns

11.4.3.3 Transmit Cycle Timing

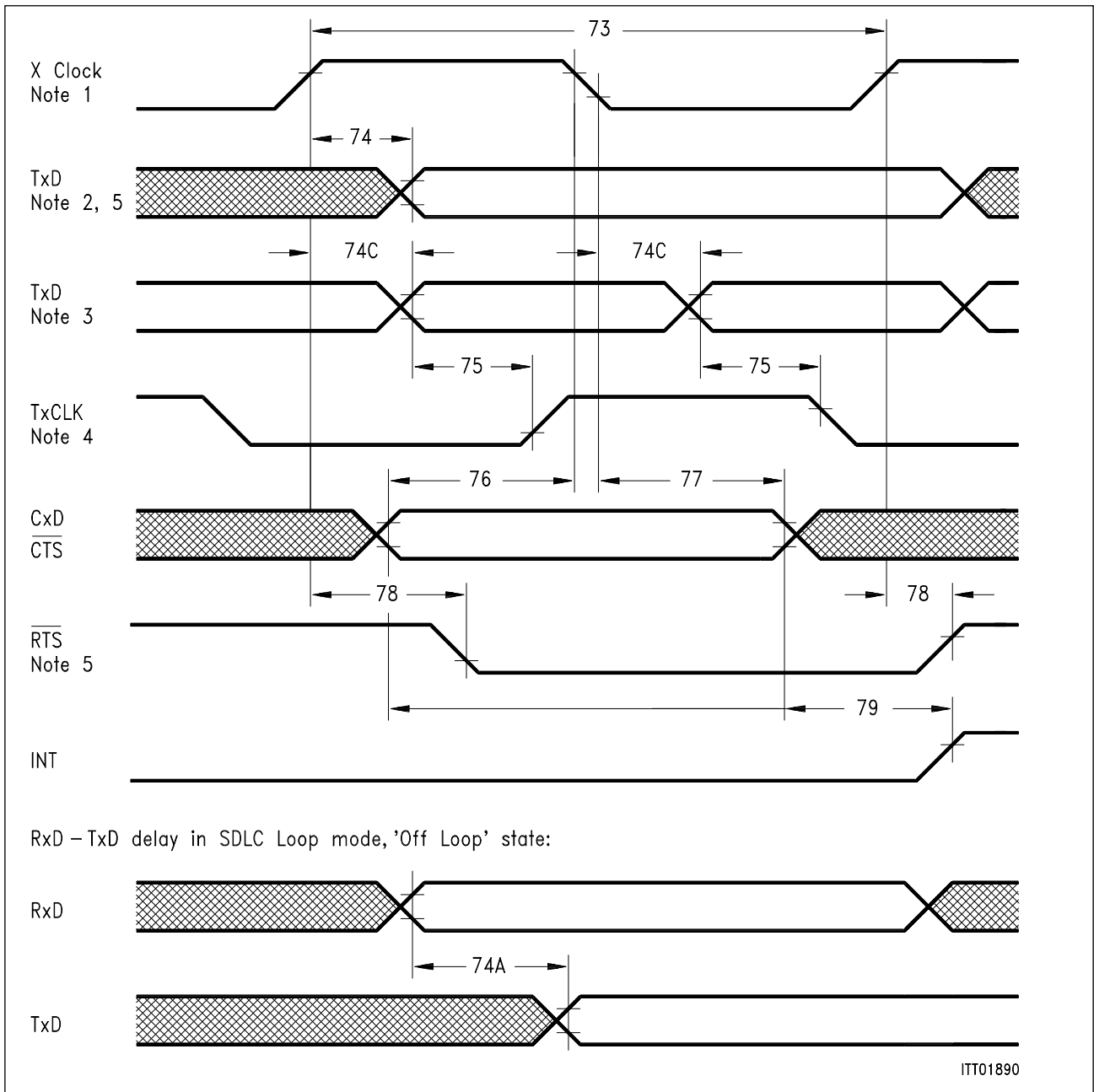

Figure 68
Transmit Cycle Timing

Note 1: Whichever supplies the clock: externally clocked by TxCLK, XTAL1 or RxCLK or, internally derived from DPLL, BRG or BCR divider (refer to table 5).

Note 2: NRZ and NRZI coding.

Note 3: FM0, FM1 and Manchester coding.

Note 4: If output function is enabled (refer to table 5).

Note 5: The timing shown is valid for normal operation and bus configuration mode 1. In bus configuration mode 2, \overline{RTS} and TxD are shifted for $1/2 \times$ clock period.

Electrical Characteristics

Transmit Cycle Timing

No.	Parameter	Symbol	Limit Values				Unit	
			N		N-10			
			min.	max.	min.	max.		
	Transmit data rate	ext. clocked (except ASYNC, BCR = 16)		2		10	Mbit/s	
		int. clocked (HDLC, BISYNC: only DPLL)		2		2	Mbit/s	
		int. clocked (all other internal modes)		2		2	Mbit/s	
73	Clock period	ext. clocked (except ASYNC, BCR = 16)	$t_{c(XC)}$	480		100	ns	
		int. clocked (HDLC, BISYNC: only DPLL)		480		480	ns	
		int. clocked (all other internal modes)		480		480	ns	
74	Transmit data delay		$t_{p(TxD)}$		55		55	ns
74c	Transmit data delay		$t_{p(TxD)}$		75		75	ns
74A	RxD to TxD delay (SDLC loop, 'Off Loop' state)		$t_{p(RxD-TxD)}$		50		50	ns
75	Clock output to transmit data delay		$t_{p(XC-TxD)}$	- 30	20	- 30	20	ns
76	Collision data and \overline{CTS} setup time		$t_{su(CxD)}$	10		10		ns
77	Collision data and \overline{CTS} hold time		$t_{h(CxD)}$	30		30		ns
78	Request to send delay	normal operation	$t_{p(RTS)}$		60		60	ns
		bus configuration			50		50	
79	\overline{CTS} status change to INT delay		$t_{CTS-INT}$		T73 + 60		T73 + 60	ns

11.4.3.4 Strobe Timing (clock mode 1)

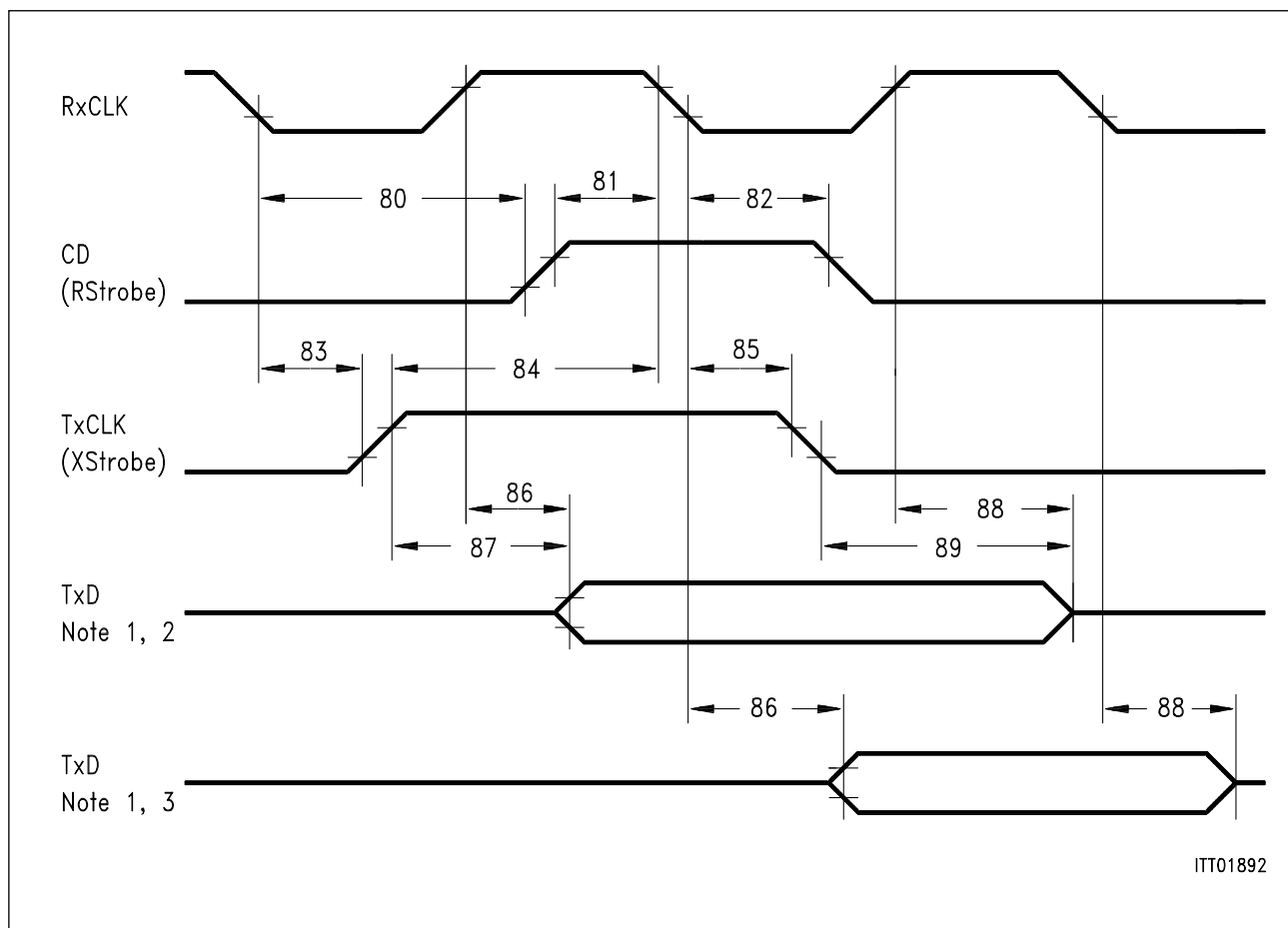

Figure 69
Strobe Timing

Note 1: High impedance if TxD is set to 'open drain' function. Otherwise, active 'high'.

Note 2: Normal operation and bus configuration mode 1.

Note 3: Bus configuration mode 2.

Electrical Characteristics

Strobe Timing

No.	Parameter	Symbol	Limit Values				Unit	
			N		N-10			
			min.	max.	min.	max.		
80	Receive strobe delay	$t_{RxCL-RS}$	30		30		ns	
81	Receive strobe setup	$t_{su(RS)}$	30		30		ns	
82	Receive strobe hold	$t_{h(RS)}$	30		30		ns	
83	Transmit strobe delay	$t_{RxCL-XS}$	30		30		ns	
84	Transmit strobe setup	$t_{su(XS)}$	30		30		ns	
85	Transmit strobe hold	$t_{h(XS)}$	30		30		ns	
86	Transmit data delay	from clock	$t_{p(RxC-TxD)}$		55		55	ns
87	Transmit data delay	from strobe	$t_{p(XS-TxD)}$		50		50	ns
88	High Impedance	from clock	$t_{dis(RxC)}$		50		50	ns
89	High Impedance	from strobe	$t_{dis(XS)}$		50		50	ns

11.4.3.5 Synchronization Timing (clock mode 5)

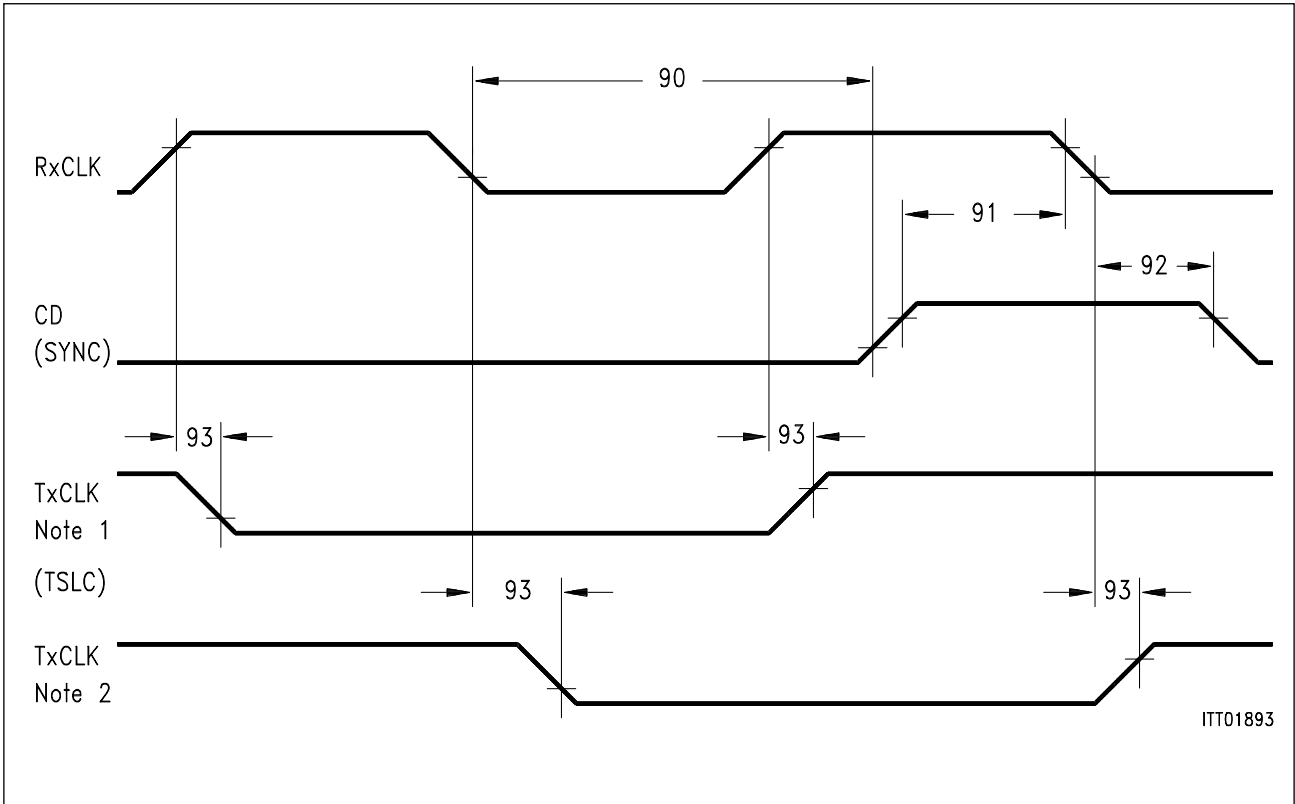

Figure 70
Synchronization Timing

Note 1: Normal operation and bus configuration mode 1.

Note 2: Bus configuration mode 2

Synchronization Timing

No.	Parameter	Symbol	Limit Values				Unit
			N		N-10		
			min.	max.	min.	max.	
90	Sync pulse delay	$t_{R \times C-SYNC}$			30		ns
91	Sync pulse setup	$t_{su(SYNC)}$			30		ns
92	Sync pulse hold	$t_{h(SYNC)}$			25		ns
93	Time-slot control delay	$t_{p(TSLC)}$			20	75	ns

Note 1: Clock mode 5 only specified for versions SAB/SAF 82532 N-10 and SAB/SAF 82532 H-10, but not for versions SAB 82532 N and SAB 82532 H.

Electrical Characteristics

11.4.3.6 Reset Timing

Reset Timing

No.	Parameter	Symbol	Limit Values				Unit
			N		N-10		
			min.	max.	min.	max.	
80	RES pulse width	$t_{w(RES)}$	5000		5000		ns

12 Package Outlines

P-LCC-68
(Plastic Leaded Chip Carrier)

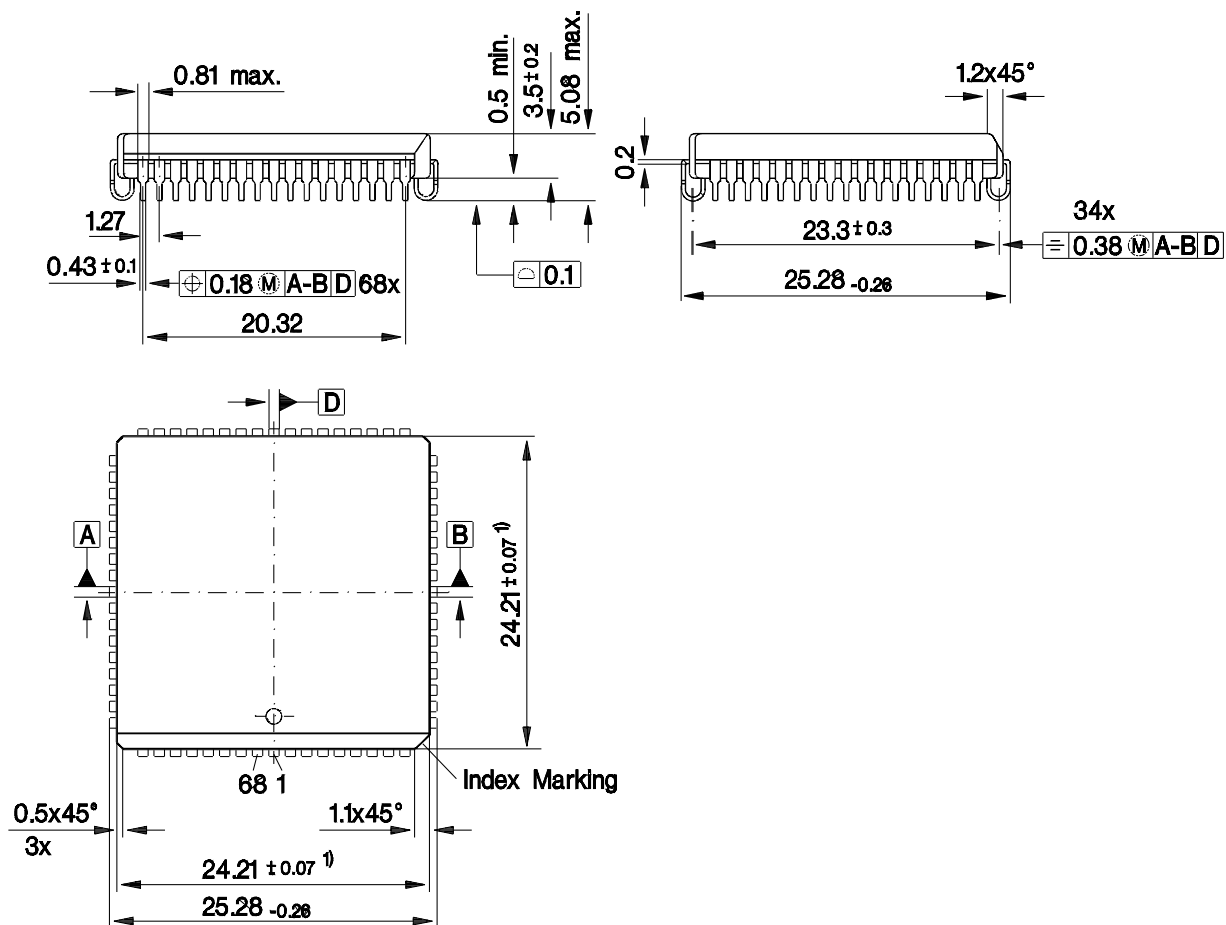

1) Does not include plastic or metal protrusion of 0.15 max. per side

GPL05099

Sorts of Packing

Package outlines for tubes, trays etc. are contained in our Data Book "Package Information".

SMD = Surface Mounted Device

Dimensions in mm

P-MQFP-80
(Plastic Metric Quad Flat Package)

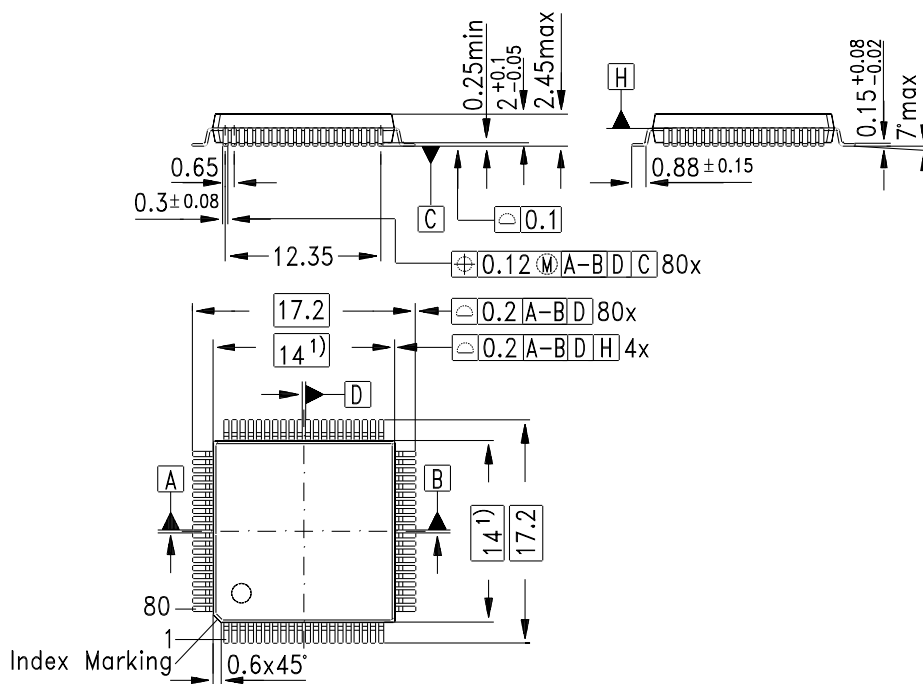

1) Does not include plastic or metal protrusions of 0.25 max per side

GPM05249

Sorts of Packing

Package outlines for tubes, trays etc. are contained in our Data Book "Package Information".

SMD = Surface Mounted Device

Dimensions in mm

13 Appendix

13.1 Baud Rate Generator Tables

Table 9
Standard Baud Rate Generator Selections

Baud Rate	Frequency [MHz]										
	2.048	3.088	6.480	8.000	8.192	9.126	12.00	15.36	16.00	16.384	18.432
300	300.5 (212)	299.7 (321)	300 (674)	200.1 (832)	300.1 (852)	300 (959)					
1200	1207.5 (52)	1206.3 (79)	1198 (168)	1201.9 (207)	1201.9 (212)	1200 (239)	1198.1 (312)	1200.0 (400)	1196.2 (417)	1196.3 (427)	1200 (479)
2400	2370.4 (26)	2412.5 (37)	2410.7 (83)	2403.8 (103)	2392.5 (106)	2400 (119)	2403.8 (155)	2400.0 (200)	2403.8 (207)	2392.5 (213)	2400 (239)
4800		4825 (19)	4821.7 (91)	4807.7 (51)		4800 (59)	4807.7 (77)	4800/0 (100)	4807.8 (103)	4785 (106)	4800 (119)
9600		9650 (9)	9642.9 (20)	9615.4 (25)	9481.5 (26)	9600 (29)	9615.4 (38)	9600.0 (50)	9615.9 (51)	9660.9 (52)	9600 (59)
19.2 K		19.3 K (4)		19.23 K (12)		19.2 K (14)	18.75 K (19)	19.2 K (25)	19.23 K (25)	18.96 K (26)	19.2 K (26)
38.4 K							37.5 K (9)		38.46 K (12)		35.4 K (14)
48.0 K		48.25 K (1)				48 K (5)	46.88 K (7)	48.0 (10)			48 K (11)
64.0 K	64 K (0)			62.5 K (3)	64 K (13)		62.5 K (5)		62.5 K (7)	64 K (7)	64 K (8)
96.0 K		96.5 K (0)				96 K (2)	93.75 (3)	96.0 (5)			96 K (5)
115.2 K											115.2K (4)
144 K						144 K (1)					144 K (3)
192 K							187.5K (1)				192K (2)
288 K						288 K (0)					288 K (1)
384 K											
CK/16 Baud (max.)	128 K	193 K	405 K	500 K	512 K	576 K	750 K	960 K	1000 K	1024 K	1152 K

The value in brackets (N + 1), where N is programmed in BR9 ... BRO.

Maximum tolerance < 2.5 %

$$F \text{ baud} = F \text{ XTAL} / (16 \times (N + 1) \times 2)$$

Table 10
Enhanced Baud Rate Generator Selections

Baud Rate	Frequency [MHz]											
	2.048	3.088	6.480	8.000	8.192	9.126	12.00	15.36	16.00	16.384	18.432	29.491
300	301.9 (53/3)	301.6 (10/6)	301.6 (21/6)	300.5 (26/6)	301.9 (53/5)	300.0 (30/6)	300.5 (39/6)	300.0 (25/7)	300.5 (26/7)	301.9 (53/6)	300.0 (30/7)	300 (48/7)
1200	1207 (53/1)	1206.3 (10/4)	1205.3 (21/4)	1201.9 (26/4)	1207 (53/3)	1200.0 (30/4)	1201.9 (39/4)	1200.0 (25/5)	1201.9 (26/5)	1207 (53/4)	1200.0 (30/5)	1200 (48/5)
2400	2415 (53/0)	2412.5 (10/3)	2410.7 (21/3)	2403.8 (26/3)	2415 (53/2)	2400.0 (30/3)	2403.8 (39/3)	2400.0 (25/4)	2403.8 (26/4)	2415 (53/3)	2400.0 (30/4)	2400 (48/4)
4800	4740.7 (27/0)	4825 (10/2)	4821 (21/2)	4807.6 (26/2)	4830 (53/1)	4800.0 (30/2)	4807.7 (39/2)	4800/0 (25/3)	4807.7 (26/3)	4830 (53/2)	4800.0 (30/3)	4800 (48/3)
9600	9846.2 ²⁾ (13/0)	9650 (10/1)	9642 (21/1)	9615.4 (26/1)	9660.4 (53/0)	9600.0 (30/1)	9615.4 (39/1)	9600.0 (25/2)	9615.4 (26/2)	9660.4 (53/1)	9600.0 (30/2)	9600 (48/2)
19.2 K		19.13 (10/0)	19.29 (21/0)	19.23 (26/0)	18.96 (27/0)	19.2 (30/0)	19.23 (39/0)	19.2 (25/1)	19.23 (26/1)	18.96 (27/1)	19.20 (30/1)	19.20 (48/1)
38.4 K		38.6 (5/0)		38.46 (13/0)	39.38 ²⁾ (13/0)	38.4 (15/0)	37.5 (10/1)	38.4 (25/0 ¹⁾)	38.46 (13/1)	39.38 (13/1)	38.4 (15/1)	38.4 (24/1)
48.0 K		48.25 (4/0)				48.0 (12/0)	46.5 (8/1)	48.0 (10/1)	50 ²⁾ (10/1)	46.54 ²⁾ (11/1)	48.0 (12/1)	48.5 (19/1)
64.0 K	64.0 (2/0)	64.33 (3/0)		62.5 (8/0)	64.0 (8/0)	64.0 (9/0)	62.5 (6/1)	64.0 (15/0 ¹⁾)	62.5 (8/1)	64.0 (8/1)	64.0 (9/1)	65.83 ²⁾ (14/1)
96.0 K		96.5 (2/0)				96.0 (6/0)	93.75 (4/1)	96.0 (5/1)			96.0 (6/1)	92.16 ²⁾ (10/1)
115.2 K						115.2 (5/0)					115.2 (5/1)	115.2 (8/1)
144 K						144.0 (4/0)			142.85 (7/1)	146.29 (7/1)	144.0 (4/1)	141.7 (13/0 ¹⁾)
192 K		193 (1/0)				192 (3/0)	187.5 (2/1)	192.0 (5/0 ¹⁾)			192.0 (3/1)	
288 K						288 (1/1)					288.0 (2/1)	
384 K							375 (1/1)					
768 K												
CK/16 Baud (max.)	128 K	193 K	405 K	500 K	512 K	576 K	750 K	960 K	1000 K	1024 K	1152 K	1843.2 K

The value in brackets is (N + 1, M¹⁾) and is used to determine the baud rate as follows:

$$\text{Baud} = \text{FXTAL}/16 \times (N + 1) \times 2 M.$$

Maximum tolerance < 2.5 % except where indicated by²⁾ when it is < 5 %.

M = 0¹⁾ may not be supported for XTAL frequencies above 10 MHz (to be characterized).

Where 0 < N < 63 and N is programmed in bits BR5 ... BR0 in register BRG

and 0 < M < 15 and M is programmed in bits BR9 ... BR6 in register BRG and CCR2 registers.

Table 11
Enhanced Baud Rate Generator Selections (continued)

Baud Rate	Frequency 29.4912 MHz
50	50 (36/10)
75	75 (48/9)
110	110 (33/9)
134.5	133.3 (54/8)
150	150 (48/8)
200	200 (36/8)
57.6K	57.6K (16/1)
76.8K	76.8 (12/1)
153.6K	153.6K (6/1)
230.4	230.4K (4/1)
307.2K	307.2K (3/1)
460.8K	460.8K (2/1)
614.4K	614.4K (3/0 ¹)
921.6	921.6K (0/1)
CK/16 Baud (max.)	1.8432

The value in brackets is (N + 1, M¹) and is used to determine the baud rate as follows:

$$\text{Baud} = \text{FXTAL}/16 \times (N + 1) \times 2 M.$$

Maximum tolerance < 2.5 % except where indicated by ²) when it is < 5 %.

M = 0¹) may not be supported for XTAL frequencies above 10 MHz (to be characterized).

Where 0 < N < 63 and N is programmed in bits BR5 ... BR0 in register BRG

and 0 < M < 15 and M is programmed in bits BR9 ... BR6 in register BRG and CCR2 registers.

13.2 Development Board EASY532

The ESCC2 datacom user board (EASY532) provides a hardware and software development tool for datacom applications using the PC as an interface to the user. The EASY532 consists of the Enhanced Serial Communication Controller (ESCC2), a microprocessor system based on the 16-bit SAB 80186, 256-Kbyte RAM, 64-Kbyte EPROM and a 2-Kbyte dual-port RAM. The board has a wiring area for small applications or special adapters can be added to connect the EASY532 with a target application outside the PC.

The EASY532 assists an engineer in developing a datacom application and greatly reduces the time spent for hardware and software development. This development kit comes with all the software drivers, board schematics and support documentation that is needed to complete either a synchronous or asynchronous datacom project. Menu driven software allows the designer to access all registers on the board and to test applications.

The EASY532 development system can serve as a reference design with schematics and software drivers. This tested application demonstrates how to build a specific datacom interface. Siemens provides these tools in a effort to shorten the customer's design cycle while assisting them to build high-quality products.

EASY532 Features

- An open hardware design that includes extensive documentation.
- Application software can be tested in advance of (or concurrent with) hardware development.
- Provided C source code drivers can be modified to fit the user's application needs.
- Time to market and design costs are reduced.
- Asynchronous, synchronous or bisync applications can be designed with the same development board.
- A user-friendly PC based interface with pull-down menus and multiple screens.
- Board installation is quick and easy.
- The EASY532 may be used as a reference hardware and software design that includes tested schematics.

Type	Ordering Code
EASY532	Q67100-H6222

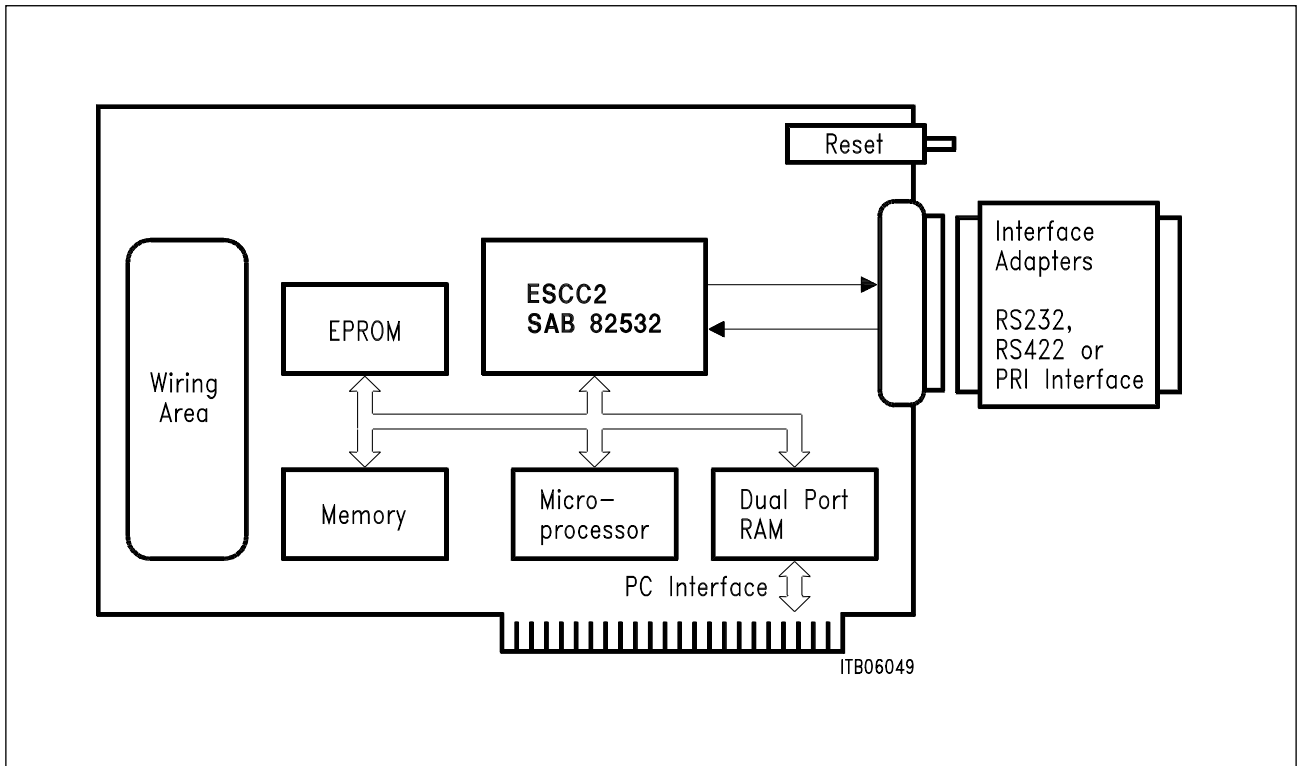

Figure 71
Block Diagram EASY532

