

TOSHIBA Transistor Silicon NPN Epitaxial Type (PCT Process)

RN1101MFV, RN1102MFV, RN1103MFV RN1104MFV, RN1105MFV, RN1106MFV

Switching, Inverter Circuit, Interface Circuit and Driver Circuit Applications

- Ultra-small package, suited to very high density mounting
- Incorporating a bias resistor into the transistor reduces the number of parts, so enabling the manufacture of ever more compact equipment and lowering assembly cost.
- A wide range of resistor values is available for use in various circuits.
- Complementary to the RN2101MFV~RN2106MFV
- Lead (Pb) - free

Equivalent Circuit and Bias Resistor Values

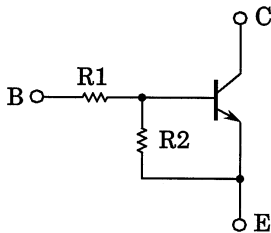

Type No.	R1 (kΩ)	R2 (kΩ)
RN1101MFV	4.7	4.7
RN1102MFV	10	10
RN1103MFV	22	22
RN1104MFV	47	47
RN1105MFV	2.2	47
RN1106MFV	4.7	47

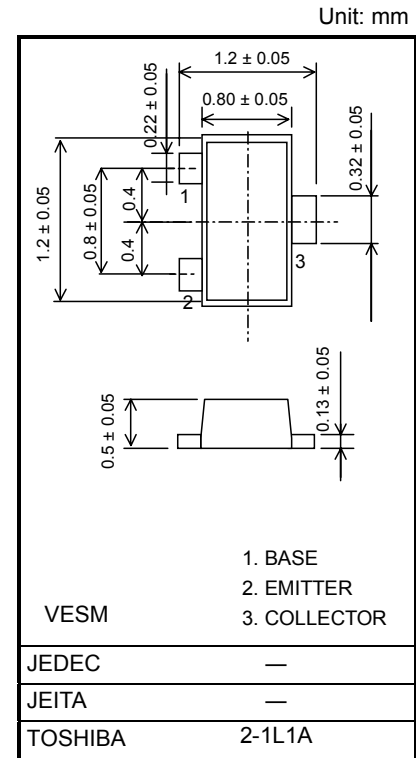

Weight: 0.0015 g (typ.)

Maximum Ratings (Ta = 25°C)

Characteristic		Symbol	Rating	Unit
Collector-base voltage	RN1101MFV~1106MFV	V_{CBO}	50	V
Collector-emitter voltage		V_{CEO}	50	V
Emitter-base voltage	RN1101MFV~1104MFV	V_{EBO}	10	V
	RN1105MFV, 1106MFV		5	
Collector current	RN1101MFV~1106MFV	I_C	100	mA
Collector power dissipation		P_C (Note)	150	mW
Junction temperature		T_j	150	°C
Storage temperature range		T_{stg}	-55~150	°C

Note: Mounted on an FR4 board (25.4 mm × 25.4 mm × 1.6 mm)

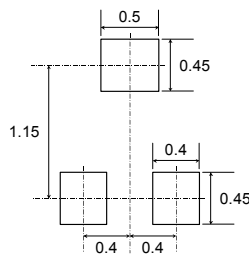

Electrical Characteristics (Ta = 25°C)

Characteristic		Symbol	Test Circuit	Test Condition	Min	Typ.	Max	Unit
Collector cutoff current	RN1101MFV~1106MFV	I_{CBO}	—	$V_{CB} = 50\text{ V}, I_E = 0$	—	—	100	nA
		I_{CEO}	—	$V_{CE} = 50\text{ V}, I_B = 0$	—	—	500	
Emitter cutoff current	RN1101MFV	I_{EBO}	—	$V_{EB} = 10\text{ V}, I_C = 0$	0.82	—	1.52	mA
	RN1102MFV				0.38	—	0.71	
	RN1103MFV				0.17	—	0.33	
	RN1104MFV				0.082	—	0.15	
	RN1105MFV			$V_{EB} = 5\text{ V}, I_C = 0$	0.078	—	0.145	
	RN1106MFV				0.074	—	0.138	
DC current gain	RN1101MFV	h_{FE}	—	$V_{CE} = 5\text{ V}, I_C = 10\text{ mA}$	30	—	—	
	RN1102MFV				50	—	—	
	RN1103MFV				70	—	—	
	RN1104MFV				80	—	—	
	RN1105MFV				80	—	—	
	RN1106MFV				80	—	—	
Collector-emitter saturation voltage	RN1101MFV~1106MFV	$V_{CE(sat)}$	—	$I_C = 5\text{ mA}, I_B = 0.25\text{ mA}$	—	0.1	0.3	V
Input voltage (ON)	RN1101MFV	$V_{I(ON)}$	—	$V_{CE} = 0.2\text{ V}, I_C = 5\text{ mA}$	1.1	—	2.0	V
	RN1102MFV				1.2	—	2.4	
	RN1103MFV				1.3	—	3.0	
	RN1104MFV				1.5	—	5.0	
	RN1105MFV				0.6	—	1.1	
	RN1106MFV				0.7	—	1.3	
Input voltage (OFF)	RN1101MFV~1104MFV	$V_{I(OFF)}$	—	$V_{CE} = 5\text{ V}, I_C = 0.1\text{ mA}$	1.0	—	1.5	V
	RN1105MFV, 1106MFV				0.5	—	0.8	
Collector output capacitance	RN1101MFV~1106MFV	C_{ob}	—	$V_{CB} = 10\text{ V}, I_E = 0, f = 1\text{ MHz}$	—	0.7	—	pF
Input resistor	RN1101MFV	R1	—	—	3.29	4.7	6.11	kΩ
	RN1102MFV				7	10	13	
	RN1103MFV				15.4	22	28.6	
	RN1104MFV				32.9	47	61.1	
	RN1105MFV				1.54	2.2	2.86	
	RN1106MFV				3.29	4.7	6.11	
Resistor ratio	RN1101MFV~1104MFV	R1/R2	—	—	0.8	1.0	1.2	
	RN1105MFV				0.0376	0.0468	0.0562	
	RN1106MFV				0.08	0.1	0.12	

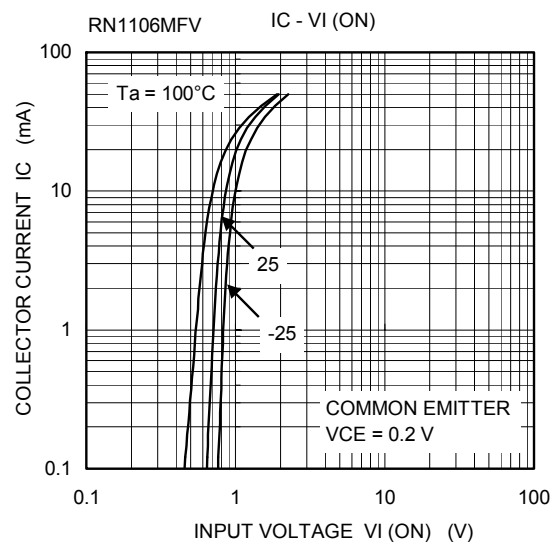
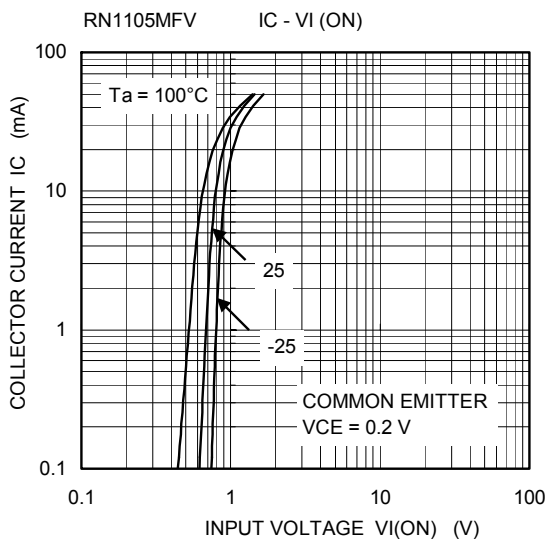
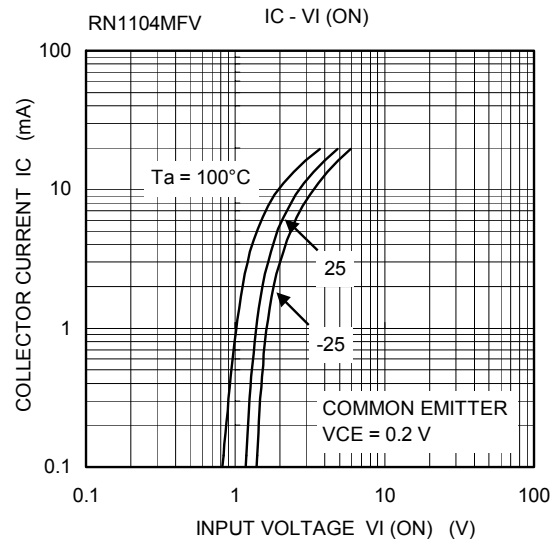
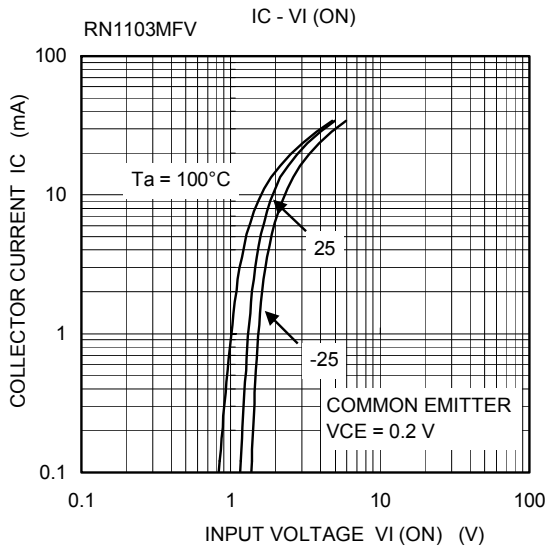
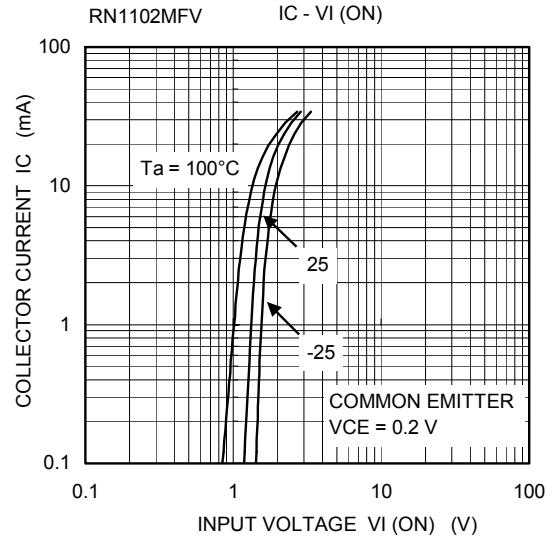
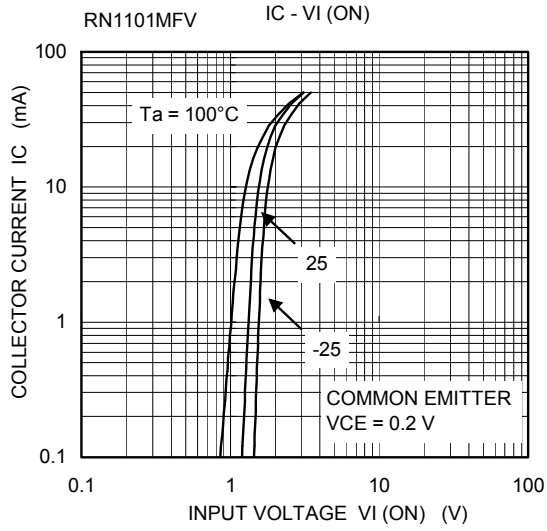

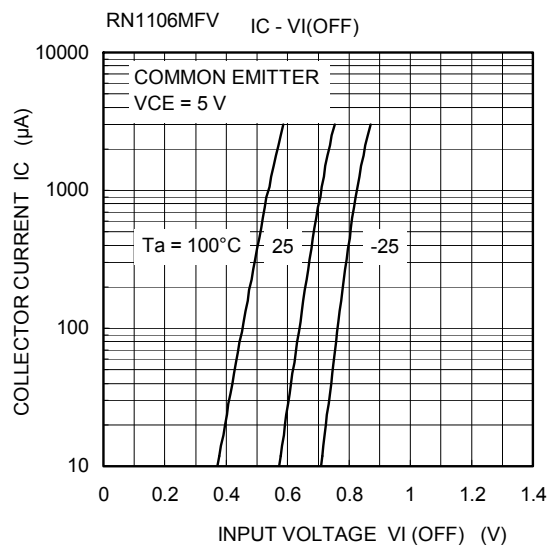
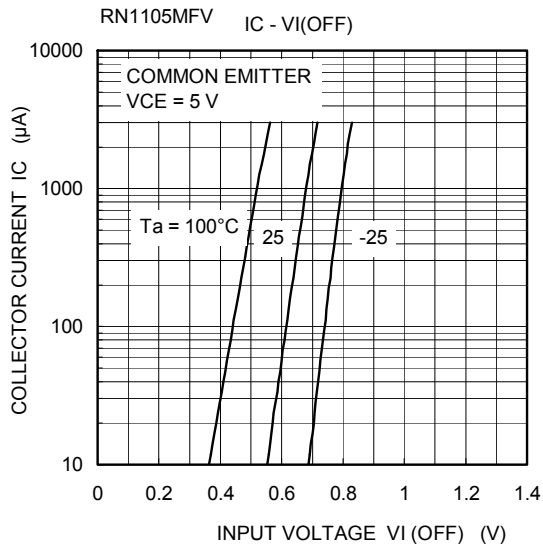
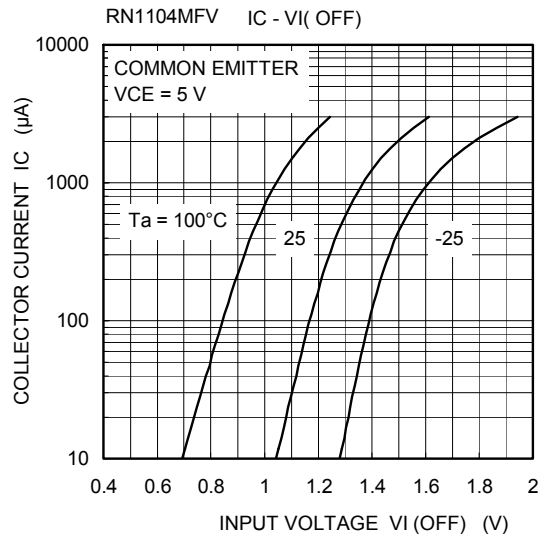
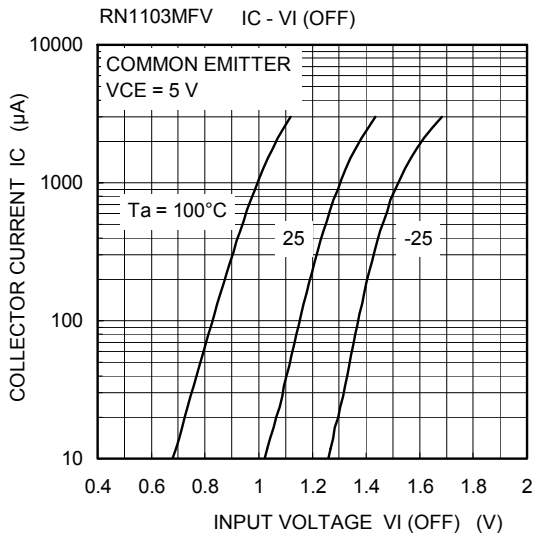
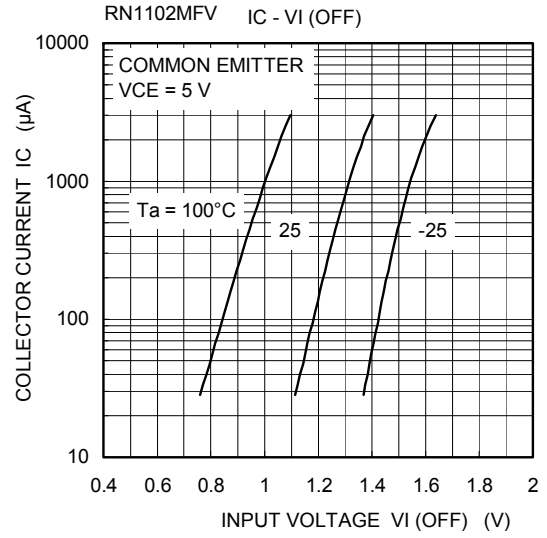
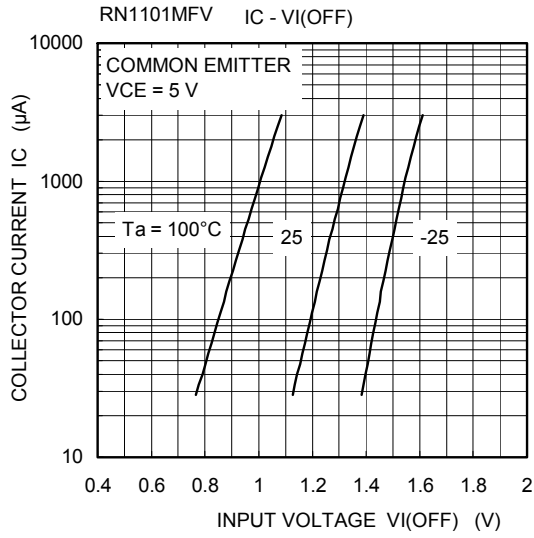

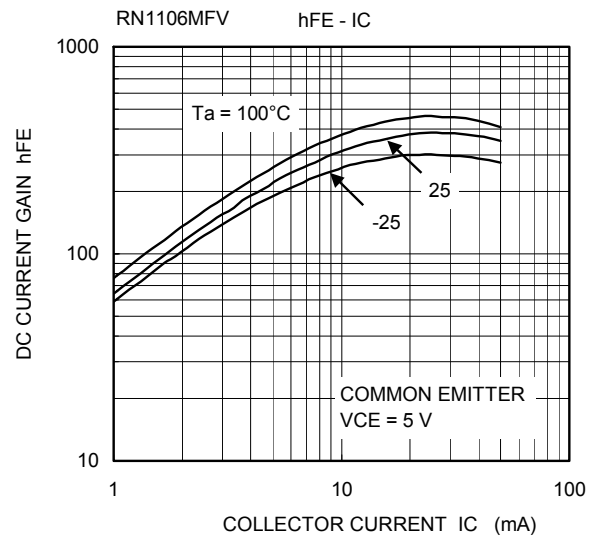
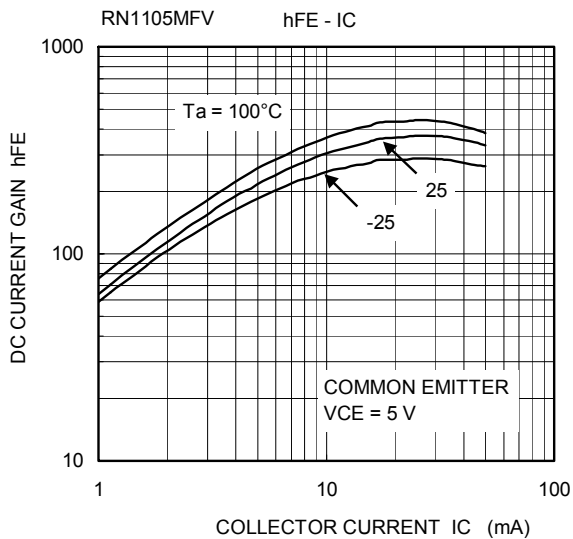
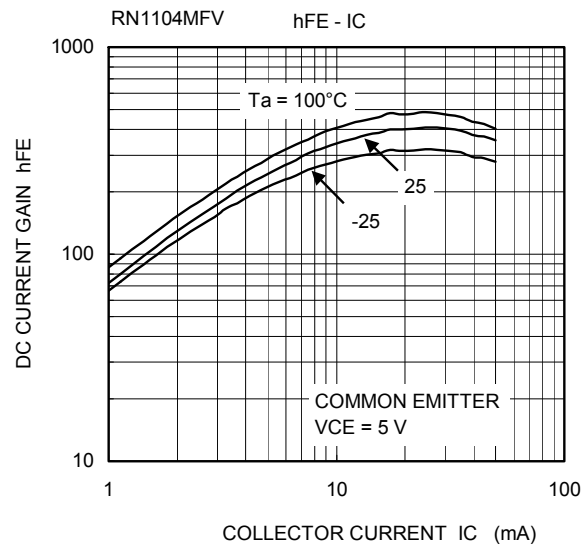
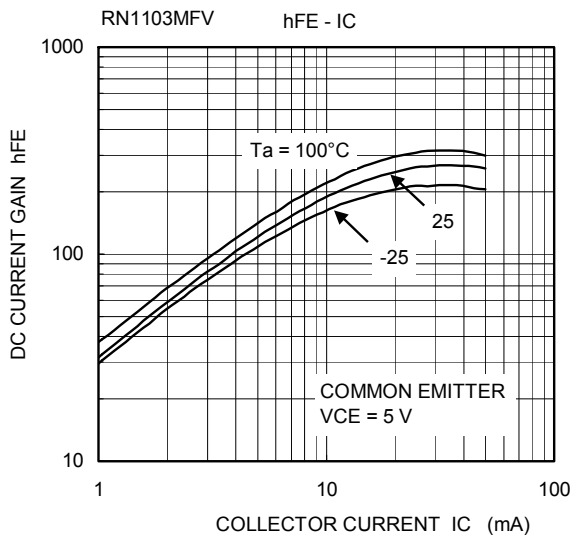
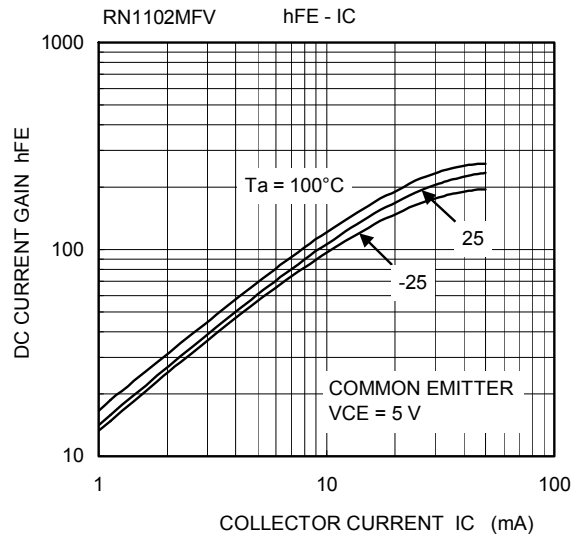
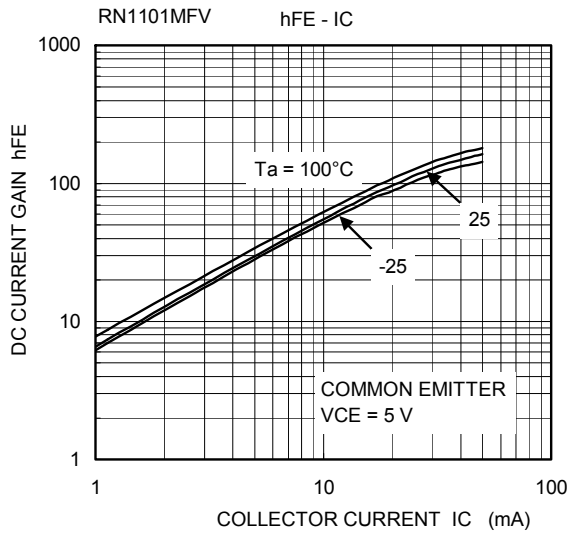

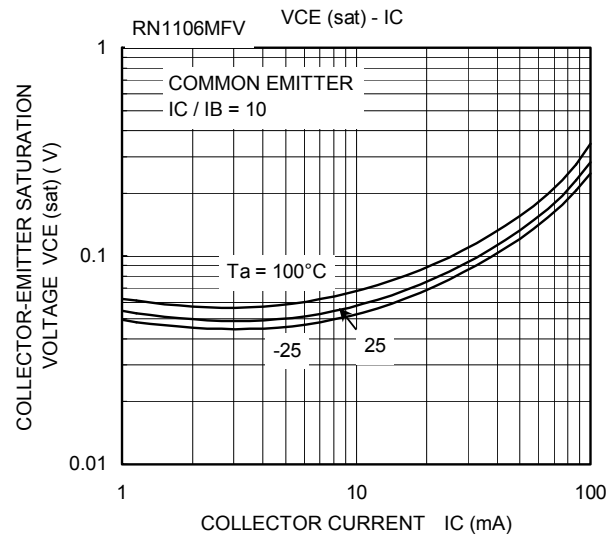
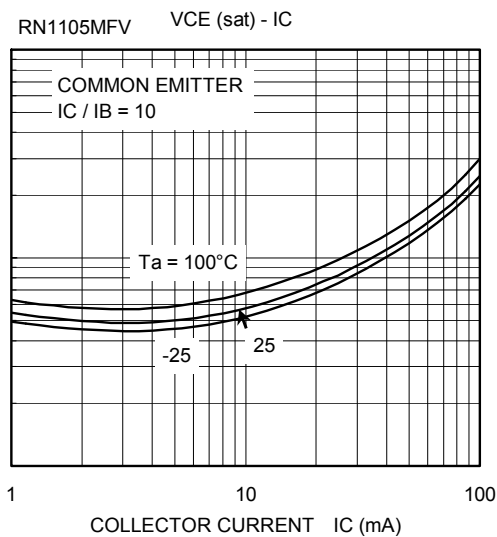
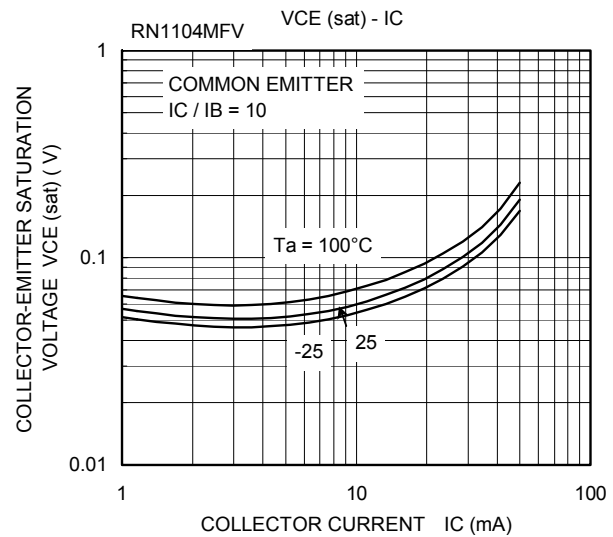
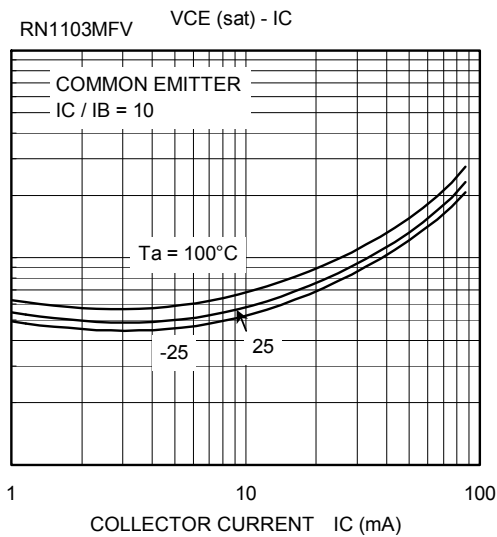
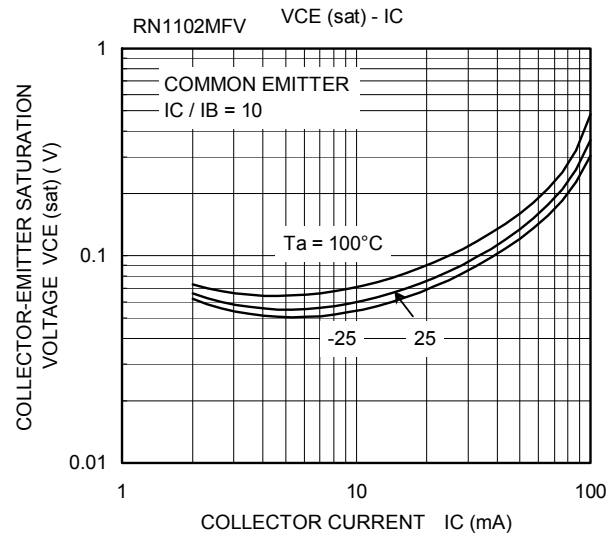
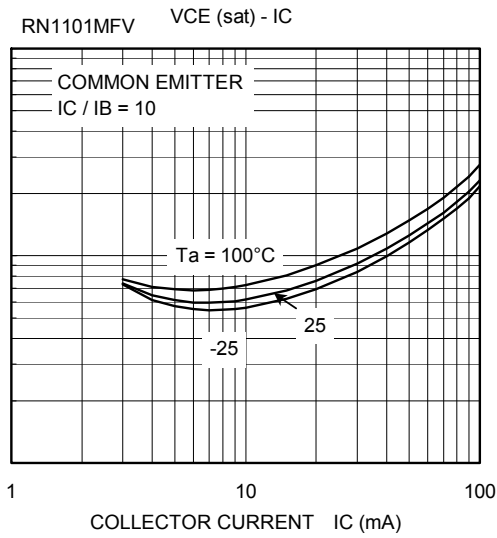

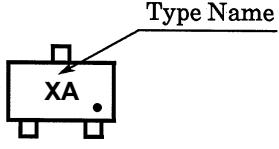
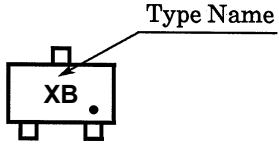
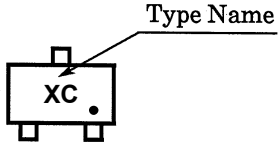
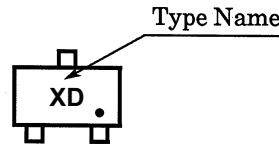
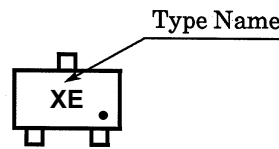
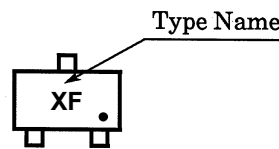
Type Name	Marking
RN1101MFV	
RN1102MFV	
RN1103MFV	
RN1104MFV	
RN1105MFV	
RN1106MFV	

RESTRICTIONS ON PRODUCT USE

030619EAA

- The information contained herein is subject to change without notice.
- The information contained herein is presented only as a guide for the applications of our products. No responsibility is assumed by TOSHIBA for any infringements of patents or other rights of the third parties which may result from its use. No license is granted by implication or otherwise under any patent or patent rights of TOSHIBA or others.
- TOSHIBA is continually working to improve the quality and reliability of its products. Nevertheless, semiconductor devices in general can malfunction or fail due to their inherent electrical sensitivity and vulnerability to physical stress. It is the responsibility of the buyer, when utilizing TOSHIBA products, to comply with the standards of safety in making a safe design for the entire system, and to avoid situations in which a malfunction or failure of such TOSHIBA products could cause loss of human life, bodily injury or damage to property.
In developing your designs, please ensure that TOSHIBA products are used within specified operating ranges as set forth in the most recent TOSHIBA products specifications. Also, please keep in mind the precautions and conditions set forth in the "Handling Guide for Semiconductor Devices," or "TOSHIBA Semiconductor Reliability Handbook" etc..
- The TOSHIBA products listed in this document are intended for usage in general electronics applications (computer, personal equipment, office equipment, measuring equipment, industrial robotics, domestic appliances, etc.). These TOSHIBA products are neither intended nor warranted for usage in equipment that requires extraordinarily high quality and/or reliability or a malfunction or failure of which may cause loss of human life or bodily injury ("Unintended Usage"). Unintended Usage include atomic energy control instruments, airplane or spaceship instruments, transportation instruments, traffic signal instruments, combustion control instruments, medical instruments, all types of safety devices, etc.. Unintended Usage of TOSHIBA products listed in this document shall be made at the customer's own risk.
- TOSHIBA products should not be embedded to the downstream products which are prohibited to be produced and sold, under any law and regulations.