



BOURNS®

Features

- Carbon element
- Insulated shaft
- Snap-in clip
- Center detent
- Center tap option
- Assorted pin layouts

Applications

- Audio/TV sets
- Car radio
- Amplifiers/mixers/drum machines/synthesizers
- PCs/monitors
- Appliances

PTV111/PTT111 - 11mm Potentiometer

Electrical Characteristics

TaperA, B
 Standard Resistance Range1K ohms to 1M ohms
 Standard Resistance Tolerance±20%
 Standard Nominal Resistance ValueSee standard resistance table
 Residual ResistanceMaximum 1%

Environmental Characteristics

Power Rating0.05 Watt
 Maximum Operating Voltage50V AC, 20V DC
 Sliding Noise100mV maximum

Physical Characteristics

Mechanical Angle300° ±5°
 Rotational Torque20 to 200 gcm
 Click Torque30 to 300 gcm
 Stop- End Strength
 no bushing5 kgcm minimum
 with bushing6 kgcm minimum
 Rotational Life10,000 cycles minimum
 Soldering Condition300°C max. within 3 seconds

Electrical Diagrams

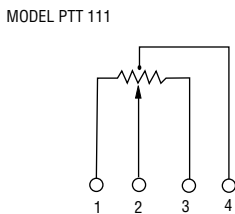
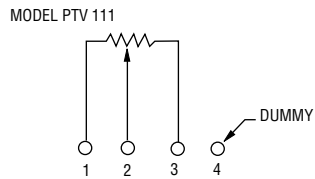

Product Dimensions

PTV111-2

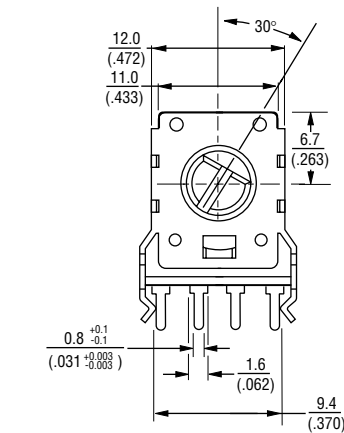
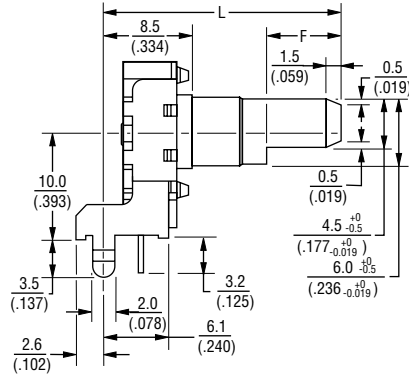

RECOMMENDED PCB LAYOUT

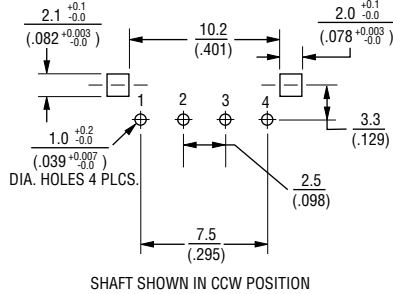

PTV111-4

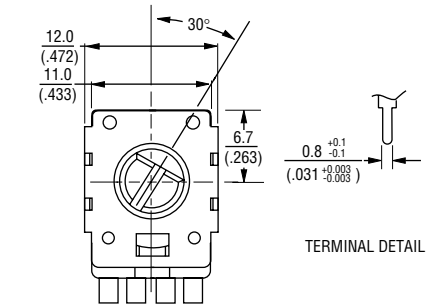
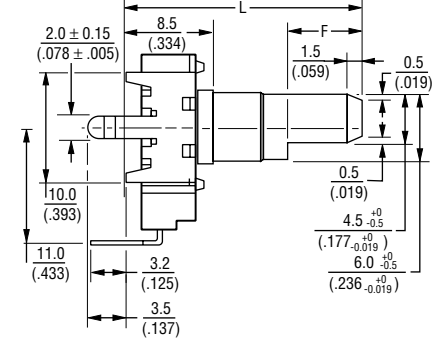

RECOMMENDED PCB LAYOUT

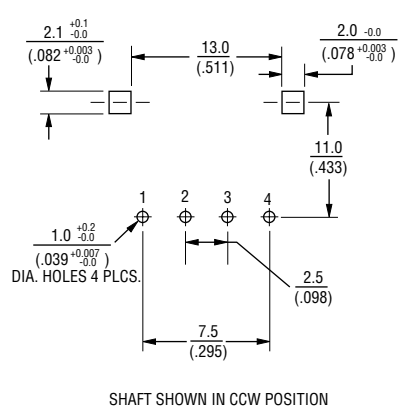

Dimensions Without Bushing

L	20	25
	(.787)	(.984)
F	7	12
	(.275)	(.472)

DIMENSIONS ARE: METRIC
 (INCHES)

PTV111/PTT111 - 11mm Potentiometer



Product Dimensions

PTV111-1

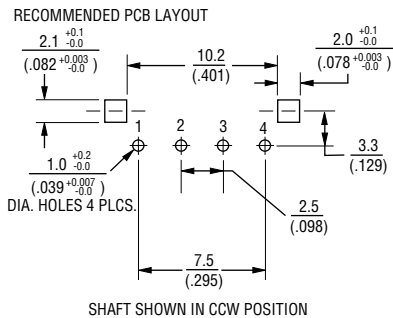
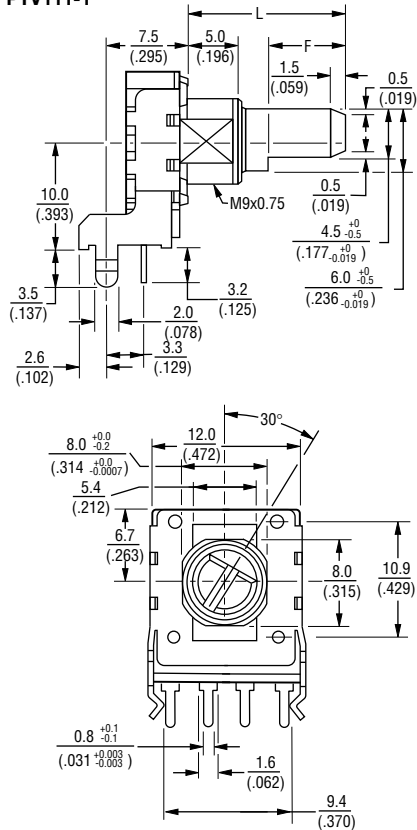

PTV111-3

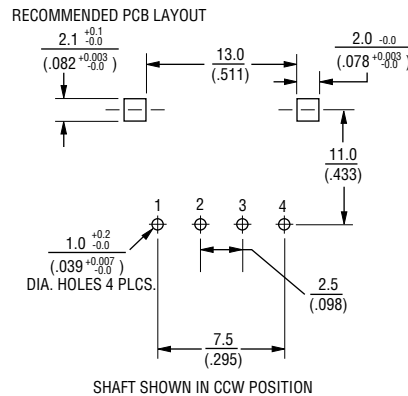
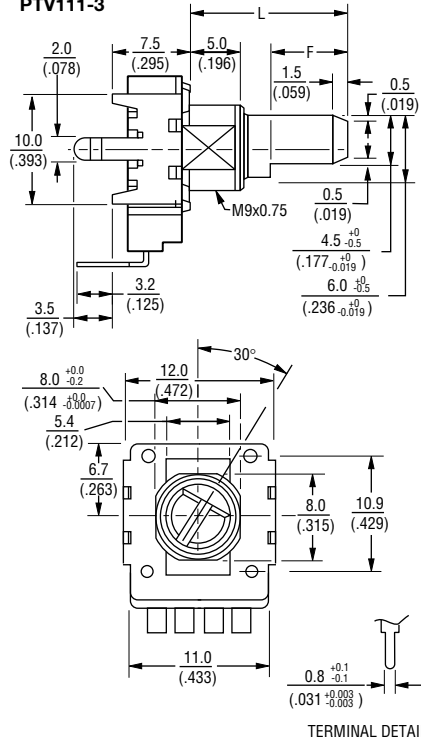

How To Order

PTV111 - 2 4 20 A - B 104

- Model (See Diagrams)
- PTV111 Standard
 - PTT111 With Tap
- Pin Style
- PC Pins vertical/Down Facing:
- 1 = With Bushing
 - 2 = No Bushing
- PC Pins horizontal/Rear Facing:
- 3 = With Bushing
 - 4 = No Bushing
- Center Detent Option
- 4 = No Detent
 - 2 = Center Detent
- Standard Shaft Length
- 15 = 15mm
 - 20 = 20mm
 - 25 = 25mm
- Shaft Styles
- A = Flat Type Insulated Shaft
- Resistance Taper
- A = Audio Taper
 - B = Linear Taper
- Resistance Code (See Table)
- Other styles available.

Standard Resistance Table

Resistance (Ohms)	Resistance Code
1,000	102
2,000	202
5,000	502
10,000	103
20,000	203
50,000	503
100,000	104
200,000	204
500,000	504
1,000,000	105

Dimensions With Bushing

L	15	20
	(.590)	(.787)
F	7	12
	(.275)	(.472)