



PSD4235G2

Flash In-System Programmable (ISP) Peripherals For 16-bit MCUs (5V Supply)

PRELIMINARY DATA

FEATURES SUMMARY

PSD provides an integrated solution to 16-bit MCU based applications that includes configurable memories, PLD logic and I/O:

- Dual Bank Flash Memories
 - 4 Mbit of Primary Flash Memory (8 uniform sectors, 32K x 16)
 - 256 Kbit Secondary Flash Memory with 4 sectors
 - Concurrent operation: read from one memory while erasing and writing the other
- 64 Kbit SRAM (Battery Backed)
- PLD with macrocells
 - Over 3000 Gates of PLD: CPLD and DPLD
 - CPLD with 16 Output Macrocells (OMCs) and 24 Input Macrocells (IMCs)
 - DPLD – user defined internal chip select decoding
- Seven I/O Ports with 52 I/O pins
 - 52 individually configurable I/O port pins that can be used for the following functions:
 - MCU I/Os
 - PLD I/Os
 - Latched MCU address output
 - Special function I/Os
 - I/O ports may be configured as open-drain outputs
- In-System Programming (ISP) with JTAG
 - Built-in JTAG compliant serial port allows full-chip In-System Programmability
 - Efficient manufacturing allow easy product testing and programming
 - Use low cost FlashLINK cable with PC
- Page Register
 - Internal page register that can be used to expand the microcontroller address space by a factor of 256
- Programmable power management
- High Endurance:
 - 100,000 Erase/Write Cycles of Flash Memory
 - 1,000 EraseWrite Cycles of PLD
 - 15 Year Data Retention
- Single Supply Voltage
 - 5V \pm 10%
- Memory Speed
 - 70ns Flash memory and SRAM access time

Figure 1. Packages

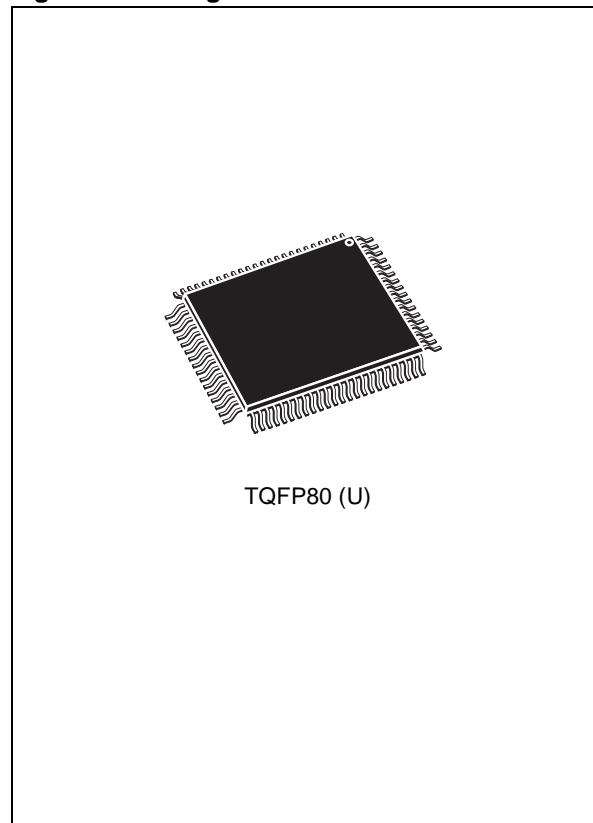

TABLE OF CONTENTS

Summary Description 5

- In-System Programming (ISP) via JTAG 5
- In-Application Programming (IAP) 6
- PSDsoft Express 7

PSD Architectural Overview 8

- Memory 8
- PLDs 8
- I/O Ports 8
- MCU Bus Interface 8
- ISP via JTAG Port 8
- In-System Programming (ISP) 8
- In-Application Programming (IAP) 8
- Page Register 9
- Power Management Unit (PMU) 9

Development System 10

Pin Description 11

PSD Register Description and Address Offsets 14

Register Bit Definition 15

Detailed Operation 20

- Memory Blocks 20
- Instructions 23
- Reading Flash Memory 23
- Programming Flash Memory 25
- Erasing Flash Memory 26
- Flash Memory Sector Protect 27
- Reset 28
- SRAM 28
- Memory Select Signals 28
- Page Register 30

Memory ID Registers	31
PLDs	31
Decode PLD (DPLD)	33
Complex PLD (CPLD)	34
MCU Bus Interface	40
I/O Ports	50
Port Operating Modes	51
Ports A, B and C – Functionality and Structure	56
Port D – Functionality and Structure	57
Port E – Functionality and Structure	57
Port F – Functionality and Structure	58
Port G – Functionality and Structure	58
Power Management	59
PLD Power Management	61
PSD Chip Select Input (CSI, PD2)	61
Power On Reset, Warm Reset and Power-down	62
Programming In-Circuit using the JTAG Serial Interface	63
Initial Delivery State	64
AC/DC Parameters	65
Table. Absolute Maximum Ratings	68
Table. Operating Conditions	69
Table. DC Characteristics	71
Table. CPLD Combinatorial Timing	72
Table. CPLD Macrocell Synchronous Clock Mode Timing	72
Table. CPLD Macrocell Asynchronous Clock Mode Timing	73
Table. Input Macrocell Timing	75
Table. Read Timing	76
Table. Write Timing	78
Table. Port F Peripheral Data Mode Read Timing	80
Table. Port F Peripheral Data Mode Write Timing	81
Table. Reset (Reset)Timing	82
Table. VSTBYON Timing	82
Table. Program, Write and Erase Times	82
Table. ISC Timing	83
Table. Power-down Timing	84

Package Mechanical	85
Table. TQFP80 - 80 lead Plastic Quad Flatpack	85
Table. Pin Assignments – TQFP80	86
Table. Ordering Information Scheme	87

SUMMARY DESCRIPTION

The PSD family of memory systems for microcontrollers (MCUs) brings In-System-Programmability (ISP) to Flash memory and programmable logic. The result is a simple and flexible solution for embedded designs. PSD devices combine many of the peripheral functions found in MCU based applications.

PSD devices integrate an optimized Macrocell logic architecture. The Macrocell was created to address the unique requirements of embedded system designs. It allows direct connection between the system address/data bus, and the internal PSD registers, to simplify communication between the MCU and other supporting devices.

Table 1. Pin Names

PA0-PA7	Port-A
PB0-PB7	Port-B
PC0-PC7	Port-C
PD0-PD3	Port-D
PE0-PE7	Port-E
PF0-PF7	Port-F
PG0-PG7	Port-G
AD0-AD15	Address/Data
CNTL0-CNTL2	Control
RESET	Reset
V _{cc}	Supply Voltage
V _{ss}	Ground

The PSD family offers two methods to program the PSD Flash memory while the PSD is soldered to the circuit board: In-System Programming (ISP) via JTAG, and In-Application Programming (IAP).

In-System Programming (ISP) via JTAG

An IEEE 1149.1 compliant JTAG In-System Programming (ISP) interface is included on the PSD enabling the entire device (Flash memories, PLD, configuration) to be rapidly programmed while soldered to the circuit board. This requires no MCU participation, which means the PSD can be programmed anytime, even when completely blank.

The innovative JTAG interface to Flash memories is an industry first, solving key problems faced by designers and manufacturing houses, such as:

Figure 2. Logic Diagram

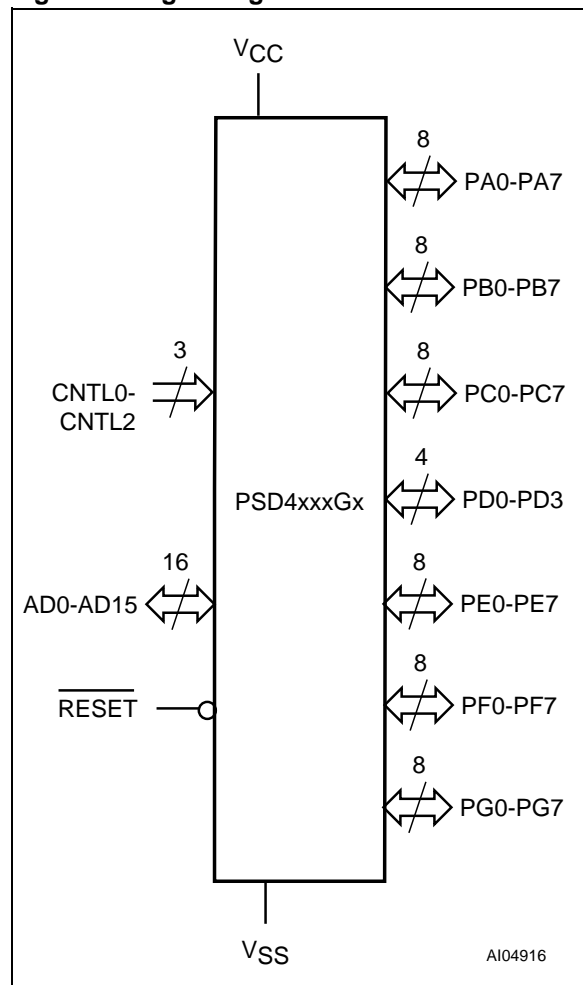

First time programming. How do I get firmware into the Flash memory the very first time? JTAG is the answer. Program the blank PSD with no MCU involvement.

Inventory build-up of pre-programmed devices. How do I maintain an accurate count of pre-programmed Flash memory and PLD devices based on customer demand? How many and what version? JTAG is the answer. Build your hardware with blank PSDs soldered directly to the board and then custom program just before they are shipped to the customer. No more labels on chips, and no more wasted inventory.

Expensive sockets. How do I eliminate the need for expensive and unreliable sockets? JTAG is the answer. Solder the PSD directly to the circuit board. Program first time and subsequent times with JTAG. No need to handle devices and bend the fragile leads.

Figure 3. TQFP Connections

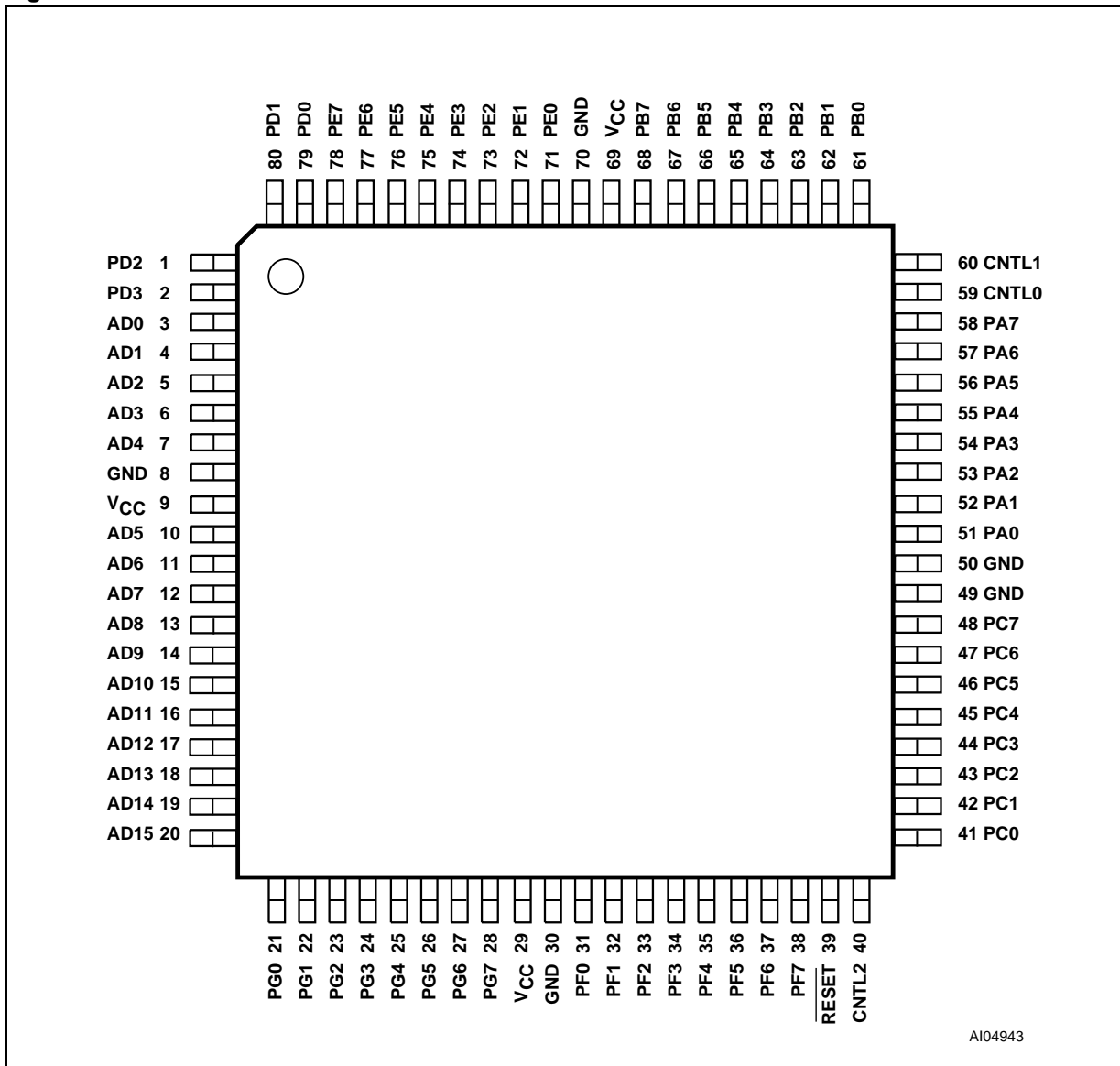

AI04943

In-Application Programming (IAP)

Two independent Flash memory arrays are included so that the MCU can execute code from one while erasing and programming the other. Robust product firmware updates in the field are possible over any communication channel (CAN, Ethernet, UART, J1850, etc) using this unique architecture. Designers are relieved of these problems:

Simultaneous read and write to Flash memory. How can the MCU program the same memory from which it is executing code? It cannot. The PSD allows the MCU to operate the two Flash memory blocks concurrently, reading code from one while erasing and programming the other during IAP.

Complex memory mapping. How can I map these two memories efficiently? A programmable

Decode PLD (DPLD) is embedded in the PSD. The concurrent PSD memories can be mapped anywhere in MCU address space, segment by segment with extremely high address resolution. As an option, the secondary Flash memory can be swapped out of the system memory map when IAP is complete. A built-in page register breaks the MCU address limit.

Separate Program and Data space. How can I write to Flash memory while it resides in Program space during field firmware updates? My 80C51XA will not allow it. The PSD provides a means to reclassify Flash memory as Data space during IAP, then back to Program space when complete.



PSDsoft Express

PSDsoft Express, a software development tool from ST, guides you through the design process step-by-step making it possible to complete an embedded MCU design capable of ISP/IAP in just hours. Select your MCU and PSDsoft Express takes you through the remainder of the design with point and click entry, covering PSD selection, pin

definitions, programmable logic inputs and output, MCU memory map definition, ANSI-C code generation for your MCU, and merging your MCU firmware with the PSD design. When complete, two different device programmers are supported directly from PSDsoft Express: FlashLINK (JTAG) and PSDpro.

Figure 4. PSD Block Diagram

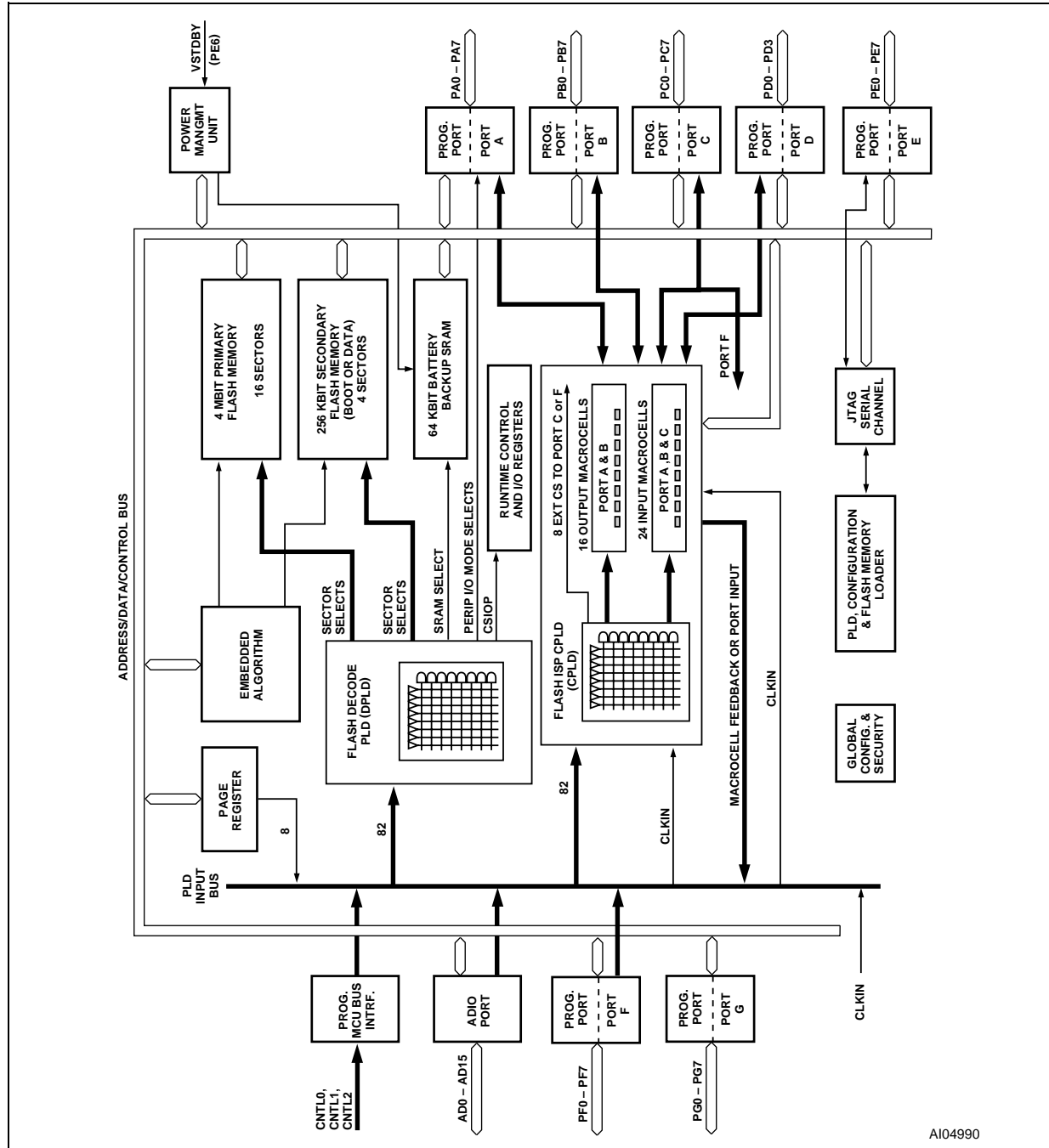

Note: Additional address lines can be brought in to the device via Port A, B, C, D or F.

PSD ARCHITECTURAL OVERVIEW

PSD devices contain several major functional blocks. Figure 4 shows the architecture of the PSD device family. The functions of each block are described briefly in the following sections. Many of the blocks perform multiple functions and are user configurable.

Memory

Each of the memory blocks is briefly discussed in the following paragraphs. A more detailed discussion can be found in the section entitled “Memory Blocks” on page 20.

The 4 Mbit primary Flash memory is the main memory of the PSD. It is divided into 8 equally-sized sectors that are individually selectable.

The 256 Kbit secondary Flash memory is divided into 4 equally-sized sectors. Each sector is individually selectable.

The 64 Kbit SRAM is intended for use as a scratch-pad memory or as an extension to the MCU SRAM. If an external battery is connected to the PSD’s Voltage Stand-by (VSTBY, PE6) signal, data is retained in the event of power failure.

Each memory block can be located in a different address space as defined by the user. The access times for all memory types includes the address latching and DPLD decoding time.

PLDs

The device contains two PLD blocks, the Decode PLD (DPLD) and the Complex PLD (CPLD), as shown in Table 2, each optimized for a different function. The functional partitioning of the PLDs reduces power consumption, optimizes cost/performance, and eases design entry.

The DPLD is used to decode addresses and to generate Sector Select signals for the PSD internal memory and registers. The DPLD has combinatorial outputs, while the CPLD can implement more general user-defined logic functions. The CPLD has 16 Output Macrocells (OMC) and 8 combinatorial outputs. The PSD also has 24 Input Macrocells (IMC) that can be configured as inputs to the PLDs. The PLDs receive their inputs from the PLD Input Bus and are differentiated by their output destinations, number of product terms, and Macrocells.

The PLDs consume minimal power. The speed and power consumption of the PLD is controlled by the Turbo bit in PMMR0 and other bits in PMMR2. These registers are set by the MCU at run-time. There is a slight penalty to PLD propagation time when not in the Turbo mode.

I/O Ports

The PSD has 52 I/O pins divided among seven ports (Port A, B, C, D, E, F and G). Each I/O pin can be individually configured for different func-

tions. Ports can be configured as standard MCU I/O ports, PLD I/O, or latched address outputs for MCUs using multiplexed address/data buses

The JTAG pins can be enabled on Port E for In-System Programming (ISP).

Table 2. PLD I/O

Name	Inputs	Outputs	Product Terms
Decode PLD (DPLD)	82	17	43
Complex PLD (CPLD)	82	24	150

MCU Bus Interface

The PSD easily interfaces easily with most 16-bit MCUs, either with multiplexed or non-multiplexed address/data buses. The device is configured to respond to the MCU’s control pins, which are also used as inputs to the PLDs.

ISP via JTAG Port

In-System Programming (ISP) can be performed through the JTAG signals on Port E. This serial interface allows complete programming of the entire PSD device. A blank device can be completely programmed. The JTAG signals (TMS, TCK, TSTAT, \overline{TERR} , TDI, TDO) can be multiplexed with other functions on Port E. Table 3 indicates the JTAG pin assignments.

In-System Programming (ISP)

Using the JTAG signals on Port E, the entire PSD device (memory, logic, configuration) can be programmed or erased without the use of the MCU.

Table 3. JTAG Signals on Port E

Port E Pins	JTAG Signal
PE0	TMS
PE1	TCK
PE2	TDI
PE3	TDO
PE4	TSTAT
PE5	\overline{TERR}

In-Application Programming (IAP)

The primary Flash memory can also be programmed, or re-programmed, in-system by the MCU executing the programming algorithms out of the secondary Flash memory, or SRAM. The secondary Flash memory can be programmed the same way by executing out of the primary Flash memory. Table 4 indicates which programming methods can program different functional blocks of the PSD.



Page Register

The 8-bit Page Register expands the address range of the MCU by up to 256 times. The paged address can be used as part of the address space to access external memory and peripherals, or internal memory and I/O. The Page Register can also be used to change the address mapping of the Flash memory blocks into different memory spaces for IAP.

Power Management Unit (PMU)

The Power Management Unit (PMU) gives the user control of the power consumption on selected functional blocks based on system requirements. The PMU includes an Automatic Power-down

(APD) Unit that turns off device functions during MCU inactivity. The APD Unit has a Power-down mode that helps reduce power consumption.

The PSD also has some bits that are configured at run-time by the MCU to reduce power consumption of the CPLD. The Turbo bit in PMMR0 can be reset to 0 and the CPLD latches its outputs and goes to Stand-by mode until the next transition on its inputs.

Additionally, bits in PMMR2 can be set by the MCU to block signals from entering the CPLD to reduce power consumption. See the section entitled "Power Management" on page 59 for more details.

Table 4. Methods of Programming Different Functional Blocks of the PSD

Functional Block	JTAG-ISP	Device Programmer	IAP
Primary Flash Memory	Yes	Yes	Yes
Secondary Flash memory	Yes	Yes	Yes
PLD Array (DPLD and CPLD)	Yes	Yes	No
PSD Configuration	Yes	Yes	No

DEVELOPMENT SYSTEM

The PSD family is supported by PSDsoft Express, a Windows-based software development tool (Windows-95, Windows-98, Windows-2000, Windows-NT). A PSD design is quickly and easily produced in a point and click environment. The designer does not need to enter Hardware Description Language (HDL) equations, unless desired, to define PSD pin functions and memory map information. The general design flow is shown in Figure 5. PSDsoft Express is available from our web site (the address is given on the back

page of this data sheet) or other distribution channels.

PSDsoft Express directly supports two low cost device programmers from ST: PSDpro and FlashLINK (JTAG). Both of these programmers may be purchased through your local distributor/representative, or directly from our web site using a credit card. The PSD is also supported by third party device programmers. See our web site for the current list.

Figure 5. PSDsoft Express Development Tool

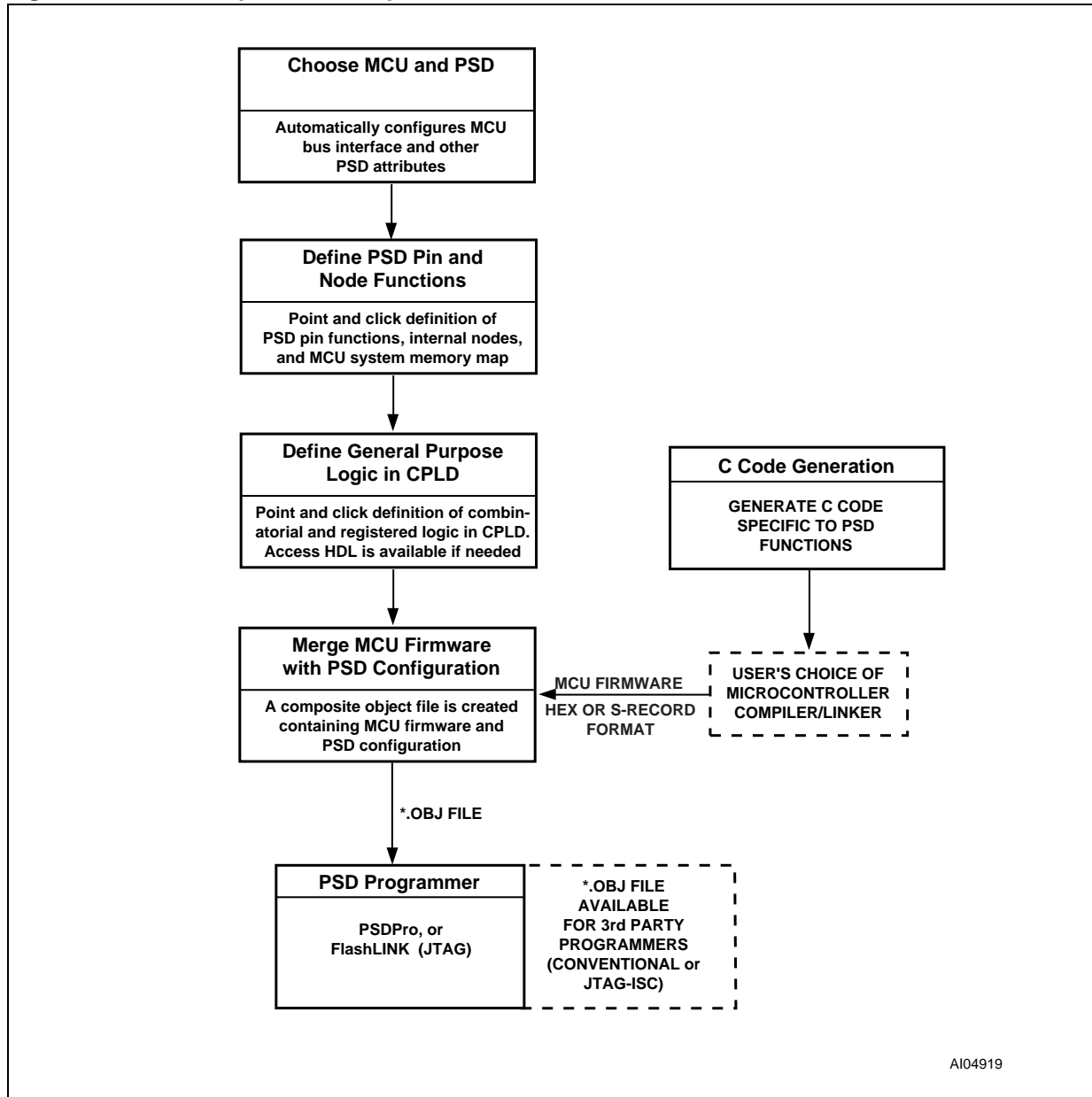

AI04919

PIN DESCRIPTION

Table 5 describes the signal names and signal functions of the PSD. Those that have multiple names or functions are defined using PSDsoft Express.

Table 5. Pin Description (for the TQFP package)

Pin Name	Pin	Type	Description
ADIO0-ADIO7	3-7 10-12	I/O	This is the lower Address/Data port. Connect your MCU address or address/data bus according to the following rules: 1. If your MCU has a multiplexed address/data bus where the data is multiplexed with the lower address bits, connect AD0-AD7 to this port. 2. If your MCU does not have a multiplexed address/data bus, connect A0-A7 to this port. 3. If you are using an 80C51XA in burst mode, connect A4/D0 through A11/D7 to this port. ALE or AS latches the address. The PSD drives data out only if the read signal is active and one of the PSD functional blocks has been selected. The addresses on this port are passed to the PLDs.
ADIO8-ADIO15	13-20	I/O	This is the upper Address/Data port. Connect your MCU address or address/data bus according to the following rules: 1. If your MCU has a multiplexed address/data bus where the data is multiplexed with the upper address bits, connect A8-A15 to this port. 2. If your MCU does not have a multiplexed address/data bus, connect A8-A15 to this port. 3. If you are using an 80C51XA in burst mode, connect A12/D8 through A19/D15 to this port. ALE or AS latches the address. The PSD drives data out only if the read signal is active and one of the PSD functional blocks has been selected. The addresses on this port are passed to the PLDs.
CNTL0	59	I	The following control signals can be connected to this pin, based on your MCU: 1. \overline{WR} – active Low, Write Strobe input. 2. R_W – active High, read/active Low write input. 3. \overline{WRL} – active Low, Write to Low-byte. This pin is connected to the PLDs. Therefore, these signals can be used in decode and other logic equations.
CNTL1	60	I	The following control signals can be connected to this pin, based on your MCU: 1. \overline{RD} – active Low, Read Strobe input. 2. E – E clock input. 3. \overline{DS} – active Low, Data Strobe input. 4. \overline{LDS} – active Low, Strobe for low data byte. This pin is connected to the PLDs. Therefore, these signals can be used in decode and other logic equations.
CNTL2	40	I	Read or other Control input pin, with multiple configurations. Depending on the MCU interface selected, this pin can be: 1. \overline{PSEN} – Program Select Enable, active Low in code fetch bus cycle (80C51XA mode). 2. \overline{BHE} – High-byte enable, 16-bit data bus. 3. \overline{UDS} – active Low, Strobe for high data byte, 16-bit data bus mode. 4. $\overline{SIZ0}$ – Byte enable input. 5. \overline{LSTRB} – Low Strobe input. This pin is also connected to the PLDs.
\overline{Reset}	39	I	Active Low input. Resets I/O Ports, PLD Macrocells and some of the Configuration Registers and JTAG registers. Must be Low at Power-up. Reset also aborts any Flash memory Program or Erase cycle that is currently in progress.

Pin Name	Pin	Type	Description
PA0-PA7	51-58	I/O CMOS or Open Drain	These pins make up Port A. These port pins are configurable and can have the following functions: 1. MCU I/O – standard output or input port. 2. CPLD Macrocell (McellA0-McellA7) outputs. 3. Latched, transparent or registered PLD inputs (can also be PLD input for address A16 and above).
PB0-PB7	61-68	I/O CMOS or Open Drain	These pins make up Port B. These port pins are configurable and can have the following functions: 1. MCU I/O – standard output or input port. 2. CPLD Macrocell (McellB0-McellB7) outputs. 3. Latched, transparent or registered PLD inputs (can also be PLD input for address A16 and above).
PC0-PC7	41-48	I/O CMOS or Slew Rate	These pins make up Port C. These port pins are configurable and can have the following functions: 1. MCU I/O – standard output or input port. 2. External Chip Select (ECS0-ECS7) outputs. 3. Latched, transparent or registered PLD inputs (can also be PLD input for address A16 and above).
PD0	79	I/O CMOS or Open Drain	PD0 pin of Port D. This port pin can be configured to have the following functions: 1. ALE/AS input – latches address on ADIO0-ADIO15. 2. \overline{AS} input – latches address on ADIO0-ADIO15 on the rising edge. 3. MCU I/O – standard output or input port. 4. Transparent PLD input (can also be PLD input for address A16 and above).
PD1	80	I/O CMOS or Open Drain	PD1 pin of Port D. This port pin can be configured to have the following functions: 1. MCU I/O – standard output or input port. 2. Transparent PLD input (can also be PLD input for address A16 and above). 3. CLKIN – clock input to the CPLD Macrocells, the APD Unit's Power-down counter, and the CPLD AND Array.
PD2	1	I/O CMOS or Open Drain	PD2 pin of Port D. This port pin can be configured to have the following functions: 1. MCU I/O – standard output or input port. 2. Transparent PLD input (can also be PLD input for address A16 and above). 3. PSD Chip Select Input (CSI). When Low, the MCU can access the PSD memory and I/O. When High, the PSD memory blocks are disabled to conserve power. The falling edge of this signal can be used to get the device out of Power-down mode.
PD3	2	I/O CMOS or Open Drain	PD3 pin of Port D. This port pin can be configured to have the following functions: 1. MCU I/O – standard output or input port. 2. Transparent PLD input (can also be PLD input for address A16 and above). 3. WRH – for 16-bit data bus, write to high byte, active low.
PE0	71	I/O CMOS or Open Drain	PE0 pin of Port E. This port pin can be configured to have the following functions: 1. MCU I/O – standard output or input port. 2. Latched address output. 3. TMS Input for the JTAG Serial Interface.
PE1	72	I/O CMOS or Open Drain	PE1 pin of Port E. This port pin can be configured to have the following functions: 1. MCU I/O – standard output or input port. 2. Latched address output. 3. TCK Input for the JTAG Serial Interface.
PE2	73	I/O CMOS or Open Drain	PE2 pin of Port E. This port pin can be configured to have the following functions: 1. MCU I/O – standard output or input port. 2. Latched address output. 3. TDI input for the JTAG Serial Interface.

Pin Name	Pin	Type	Description
PE3	74	I/O CMOS or Open Drain	PE3 pin of Port E. This port pin can be configured to have the following functions: 1. MCU I/O – standard output or input port. 2. Latched address output. 3. TDO output for the JTAG Serial Interface.
PE4	75	I/O CMOS or Open Drain	PE4 pin of Port E. This port pin can be configured to have the following functions: 1. MCU I/O – standard output or input port. 2. Latched address output. 3. TSTAT output for the JTAG Serial Interface. 4. Ready/Busy output for parallel In-System Programming (ISP).
PE5	76	I/O CMOS or Open Drain	PE5 pin of Port E. This port pin can be configured to have the following functions: 1. MCU I/O – standard output or input port. 2. Latched address output. 3. $\overline{\text{TERR}}$ active Low output for the JTAG Serial Interface.
PE6	77	I/O CMOS or Open Drain	PE6 pin of Port E. This port pin can be configured to have the following functions: 1. MCU I/O – standard output or input port. 2. Latched address output. 3. VSTBY – SRAM stand-by voltage input for SRAM battery backup.
PE7	78	I/O CMOS or Open Drain	PE7 pin of Port E. This port pin can be configured to have the following functions: 1. MCU I/O – standard output or input port. 2. Latched address output. 3. Battery-on Indicator (VBATON). Goes High when power is being drawn from the external battery.
PF0-PF7	31-38	I/O CMOS or Open Drain	These pins make up Port F. These port pins are configurable and can have the following functions: 1. MCU I/O – standard output or input port. 2. External Chip Select (ECS0-ECS7) outputs, or inputs to CPLD. 3. Latched address outputs. 4. Address A1-A3 inputs in 80C51XA mode (PF0 is grounded) 5. Data bus port (D0-D7) in a non-multiplexed bus configuration. 6. Peripheral I/O mode. 7. MCU reset mode.
PG0-PG7	21-28	I/O CMOS or Open Drain	These pins make up Port G. These port pins are configurable and can have the following functions: 1. MCU I/O – standard output or input port. 2. Latched address outputs. 3. Data bus port (D8-D15) in a non-multiplexed bus configuration. 4. MCU reset mode.
VCC	9, 29, 69		Supply Voltage
GND	8, 30, 49, 50, 70		Ground pins

PSD REGISTER DESCRIPTION AND ADDRESS OFFSETS

Table 6 shows the offset addresses to the PSD registers relative to the CSIOP base address. The CSIOP space is the 256 bytes of address that is allocated by the user to the internal PSD registers.

Table 6 provides brief descriptions of the registers in CSIOP space. The following sections give a more detailed description.

Table 6. Register Address Offset

Register Name	Port A	Port B	Port C	Port D	Port E	Port F	Port G	Other ¹	Description
Data In	00	01	10	11	30	40	41		Reads Port pin as input, MCU I/O input mode
Control					32	42	43		Selects mode between MCU I/O or Address Out
Data Out	04	05	14	15	34	44	45		Stores data for output to Port pins, MCU I/O output mode
Direction	06	07	16	17	36	46	47		Configures Port pin as input or output
Drive Select	08	09	18	19	38	48	49		Configures Port pins as either CMOS or Open Drain on some pins, while selecting high slew rate on other pins.
Input Macrocell	0A	0B		1A					Reads Input Macrocells
Enable Out	0C	0D	1C				4C		Reads the status of the output enable to the I/O Port driver
Output Macrocells A	20								Read – reads output of Macrocells A Write – loads Macrocell Flip-flops
Output Macrocells B		21							Read – reads output of Macrocells B Write – loads Macrocell Flip-flops
Mask Macrocells A	22								Blocks writing to the Output Macrocells A
Mask Macrocells B		23							Blocks writing to the Output Macrocells B
Flash Memory Protection								C0	Read only – Primary Flash Sector Protection
Flash Boot Protection								C2	Read only – PSD Security and Secondary Flash memory Sector Protection
JTAG Enable								C7	Enables JTAG Port
PMMR0								B0	Power Management Register 0
PMMR2								B4	Power Management Register 2
Page								E0	Page Register
VM								E2	Places PSD memory areas in Program and/or Data space on an individual basis.
Memory_ID0								F0	Read only – SRAM and Primary memory size
Memory_ID1								F1	Read only – Secondary memory type and size

Note: 1. Other registers that are not part of the I/O ports.

REGISTER BIT DEFINITION

All the registers of the PSD are included here, for reference. Detailed descriptions of these registers can be found in the following sections.

Table 7. Data-In Registers – Ports A, B, C, D, E, F, G

Bit 7	Bit 6	Bit 5	Bit 4	Bit 3	Bit 2	Bit 1	Bit 0
Port pin 7	Port pin 6	Port pin 5	Port pin 4	Port pin 3	Port pin 2	Port pin 1	Port pin 0

Note: Bit Definitions (Read-only registers):
Read Port pin status when Port is in MCU I/O input mode.

Table 8. Data-Out Registers – Ports A, B, C, D, E, F, G

Bit 7	Bit 6	Bit 5	Bit 4	Bit 3	Bit 2	Bit 1	Bit 0
Port pin 7	Port pin 6	Port pin 5	Port pin 4	Port pin 3	Port pin 2	Port pin 1	Port pin 0

Note: Bit Definitions:
Latched data for output to Port pin when pin is configured in MCU I/O output mode.

Table 9. Direction Registers – Ports A, B, C, D, E, F, G

Bit 7	Bit 6	Bit 5	Bit 4	Bit 3	Bit 2	Bit 1	Bit 0
Port pin 7	Port pin 6	Port pin 5	Port pin 4	Port pin 3	Port pin 2	Port pin 1	Port pin 0

Note: Bit Definitions:
Port pin <i>0</i> = Port pin <i>0</i> is configured in Input mode (default).
Port pin <i>1</i> = Port pin <i>1</i> is configured in Output mode.

Table 10. Control Registers – Ports E, F, G

Bit 7	Bit 6	Bit 5	Bit 4	Bit 3	Bit 2	Bit 1	Bit 0
Port pin 7	Port pin 6	Port pin 5	Port pin 4	Port pin 3	Port pin 2	Port pin 1	Port pin 0

Note: Bit Definitions:
Port pin <i>0</i> = Port pin <i>0</i> is configured in MCU I/O mode (default).
Port pin <i>1</i> = Port pin <i>1</i> is configured in Latched Address Out mode.

Table 11. Drive Registers – Ports A, B, D, E, G

Bit 7	Bit 6	Bit 5	Bit 4	Bit 3	Bit 2	Bit 1	Bit 0
Port pin 7	Port pin 6	Port pin 5	Port pin 4	Port pin 3	Port pin 2	Port pin 1	Port pin 0

Note: Bit Definitions:
Port pin <i>0</i> = Port pin <i>0</i> is configured for CMOS Output driver (default).
Port pin <i>1</i> = Port pin <i>1</i> is configured for Open Drain output driver.

Table 12. Drive Registers – Ports C, F

Bit 7	Bit 6	Bit 5	Bit 4	Bit 3	Bit 2	Bit 1	Bit 0
Port pin 7	Port pin 6	Port pin 5	Port pin 4	Port pin 3	Port pin 2	Port pin 1	Port pin 0

Note: Bit Definitions:
Port pin <i>0</i> = Port pin <i>0</i> is configured for CMOS Output driver (default).
Port pin <i>1</i> = Port pin <i>1</i> is configured in Slew Rate mode.

Table 13. Enable-Out Registers – Ports A, B, C, F

Bit 7	Bit 6	Bit 5	Bit 4	Bit 3	Bit 2	Bit 1	Bit 0
Port pin 7	Port pin 6	Port pin 5	Port pin 4	Port pin 3	Port pin 2	Port pin 1	Port pin 0

Note: Bit Definitions (Read-only registers):
Port pin <i> 0 = Port pin <i> is in tri-state driver (default).
Port pin <i> 1 = Port pin <i> is enabled.

Table 14. Input Macrocells – Ports A, B, C

Bit 7	Bit 6	Bit 5	Bit 4	Bit 3	Bit 2	Bit 1	Bit 0
IMcell 7	IMcell 6	IMcell 5	IMcell 4	IMcell 3	IMcell 2	IMcell 1	IMcell 0

Note: Bit Definitions (Read-only registers):
 Read Input Macrocell (IMC7-IMC0) status on Ports A, B and C.

Table 15. Output Macrocells A Register

Bit 7	Bit 6	Bit 5	Bit 4	Bit 3	Bit 2	Bit 1	Bit 0
Mcella 7	Mcella 6	Mcella 5	Mcella 4	Mcella 3	Mcella 2	Mcella 1	Mcella 0

Note: Bit Definitions:
Write Register: Load MCellA7-MCellA0 with 0 or 1.
Read Register: Read MCellA7-MCellA0 output status.

Table 16. Output Macrocells B Register

Bit 7	Bit 6	Bit 5	Bit 4	Bit 3	Bit 2	Bit 1	Bit 0
Mcellb 7	Mcellb 6	Mcellb 5	Mcellb 4	Mcellb 3	Mcellb 2	Mcellb 1	Mcellb 0

Note: Bit Definitions:
Write Register: Load MCellB7-MCellB0 with 0 or 1.
Read Register: Read MCellB7-MCellB0 output status.

Table 17. Mask Macrocells A Register

Bit 7	Bit 6	Bit 5	Bit 4	Bit 3	Bit 2	Bit 1	Bit 0
Mcella 7	Mcella 6	Mcella 5	Mcella 4	Mcella 3	Mcella 2	Mcella 1	Mcella 0

Note: Bit Definitions:
McellA<i>_Prot 0 = Allow MCellA<i> flip-flop to be loaded by MCU (default).
McellA<i>_Prot 1 = Prevent MCellA<i> flip-flop from being loaded by MCU.

Table 18. Mask Macrocells B Register

Bit 7	Bit 6	Bit 5	Bit 4	Bit 3	Bit 2	Bit 1	Bit 0
Mcellb 7	Mcellb 6	Mcellb 5	Mcellb 4	Mcellb 3	Mcellb 2	Mcellb 1	Mcellb 0

Note: Bit Definitions:
McellB<i>_Prot 0 = Allow MCellB<i> flip-flop to be loaded by MCU (default).
McellB<i>_Prot 1 = Prevent MCellB<i> flip-flop from being loaded by MCU.

Table 19. Flash Memory Protection Register

Bit 7	Bit 6	Bit 5	Bit 4	Bit 3	Bit 2	Bit 1	Bit 0
Sec7_Prot	Sec6_Prot	Sec5_Prot	Sec4_Prot	Sec3_Prot	Sec2_Prot	Sec1_Prot	Sec0_Prot

Note: Bit Definitions (Read-only register):
Sec<i>_Prot 1 = Primary Flash memory Sector <i> is write protected.
Sec<i>_Prot 0 = Primary Flash memory Sector <i> is not write protected.

Table 20. Flash Boot Protection Register

Bit 7	Bit 6	Bit 5	Bit 4	Bit 3	Bit 2	Bit 1	Bit 0
Security_Bit	not used	not used	not used	Sec3_Prot	Sec2_Prot	Sec1_Prot	Sec0_Prot

Note: Bit Definitions:

Sec<i>_Prot 1 = Secondary Flash memory Sector <i> is write protected.

Sec<i>_Prot 0 = Secondary Flash memory Sector <i> is not write protected.

Security_Bit 0 = Security Bit in device has not been set.

Security_Bit 1 = Security Bit in device has been set.

Table 21. JTAG Enable Register

Bit 7	Bit 6	Bit 5	Bit 4	Bit 3	Bit 2	Bit 1	Bit 0
not used	not used	not used	not used	not used	not used	not used	JTAGEnable

Note: Bit Definitions:

JTAGEnable 1 = JTAG Port is enabled.

JTAGEnable 0 = JTAG Port is disabled.

Table 22. Page Register

Bit 7	Bit 6	Bit 5	Bit 4	Bit 3	Bit 2	Bit 1	Bit 0
PGR 7	PGR 6	PGR 5	PGR 4	PGR 3	PGR 2	PGR 1	PGR 0

Note: Bit Definitions:

Configure Page input to PLD. Default is PGR7-PGR0=0.

Table 23. PMMR0 Register

Bit 7	Bit 6	Bit 5	Bit 4	Bit 3	Bit 2	Bit 1	Bit 0
not used (set to 0)	not used (set to 0)	PLD MCells CLK	PLD Array CLK	PLD Turbo	not used (set to 0)	APD Enable	not used (set to 0)

Note: The bits of this register are cleared to zero following Power-up. Subsequent Reset (Reset) pulses do not clear the registers.

Note: Bit Definitions:

- APD Enable** 0 = Automatic Power-down (APD) is disabled.
1 = Automatic Power-down (APD) is enabled.
- PLD Turbo** 0 = PLD Turbo is on.
1 = PLD Turbo is off, saving power.
- PLD Array CLK** 0 = CLKIN to the PLD AND array is connected. Every CLKIN change powers up the PLD when Turbo bit is off.
1 = CLKIN to the PLD AND array is disconnected, saving power.
- PLD MCells CLK** 0 = CLKIN to the PLD Macrocells is connected.
1 = CLKIN to the PLD Macrocells is disconnected, saving power.

Table 24. PMMR2 Register

Bit 7	Bit 6	Bit 5	Bit 4	Bit 3	Bit 2	Bit 1	Bit 0
not used (set to 0)	PLD Array WRH	PLD Array ALE	PLD Array CNTL2	PLD Array CNTL1	PLD Array CNTL0	not used (set to 0)	PLD Array Addr

Note: For Bit 4, Bit 3, Bit 2: See Table 34 for the signals that are blocked on pins CNTL0-CNTL2.

Note: Bit Definitions:

- PLD Array Addr** 0 = Address A7-A0 are connected to the PLD array.
1 = Address A7-A0 are blocked from the PLD array, saving power.
(Note: in XA mode, A3-A0 come from PF3-PF0, and A7-A4 come from ADIO7-ADIO4)
- PLD Array CNTL2** 0 = CNTL2 input to the PLD AND array is connected.
1 = CNTL2 input to the PLD AND array is disconnected, saving power.
- PLD Array CNTL1** 0 = CNTL1 input to the PLD AND array is connected.
1 = CNTL1 input to the PLD AND array is disconnected, saving power.
- PLD Array CNTL0** 0 = CNTL0 input to the PLD AND array is connected.
1 = CNTL0 input to the PLD AND array is disconnected, saving power.
- PLD Array ALE** 0 = ALE input to the PLD AND array is connected.
1 = ALE input to the PLD AND array is disconnected, saving power.
- PLD Array WRH** 0 = WRH/DBE input to the PLD AND array is connected.
1 = WRH/DBE input to the PLD AND array is disconnected, saving power.

Table 25. VM Register

Bit 7	Bit 6	Bit 5	Bit 4	Bit 3	Bit 2	Bit 1	Bit 0
Peripheral mode	not used (set to 0)	not used (set to 0)	FL_data	Boot_data	FL_code	Boot_code	SR_code

Note: On reset, Bit1-Bit4 are loaded to configurations that are selected by the user in PSDsoft Express. Bit0 and Bit7 are always cleared on reset. Bit0-Bit4 are active only when the device is configured in Philips 80C51XA mode.

Note: Bit Definitions:

- SR_code** 0 = \overline{PSEN} cannot access SRAM in 80C51XA modes.
1 = \overline{PSEN} can access SRAM in 80C51XA modes.
- Boot_code** 0 = \overline{PSEN} cannot access Secondary NVM in 80C51XA modes.
1 = \overline{PSEN} can access Secondary NVM in 80C51XA modes.
- FL_code** 0 = \overline{PSEN} cannot access Primary Flash memory in 80C51XA modes.
1 = \overline{PSEN} can access Primary Flash memory in 80C51XA modes.
- Boot_data** 0 = \overline{RD} cannot access Secondary NVM in 80C51XA modes.
1 = \overline{RD} can access Secondary NVM in 80C51XA modes.
- FL_data** 0 = \overline{RD} cannot access Primary Flash memory in 80C51XA modes.
1 = \overline{RD} can access Primary Flash memory in 80C51XA modes.
- Peripheral mode** 0 = Peripheral mode of Port F is disabled.
1 = Peripheral mode of Port F is enabled.

Table 26. Memory_ID0 Register

Bit 7	Bit 6	Bit 5	Bit 4	Bit 3	Bit 2	Bit 1	Bit 0
S_size 3	S_size 2	S_size 1	S_size 0	F_size 3	F_size 2	F_size 1	F_size 0

Note: Bit Definitions:

F_size[3:0]	0h = There is no Primary Flash memory 1h = Primary Flash memory size is 256 Kbit 2h = Primary Flash memory size is 512 Kbit 3h = Primary Flash memory size is 1 Mbit 4h = Primary Flash memory size is 2 Mbit 5h = Primary Flash memory size is 4 Mbit 6h = Primary Flash memory size is 8 Mbit
S_size[3:0]	0h = There is no SRAM 1h = SRAM size is 16 Kbit 2h = SRAM size is 32 Kbit 3h = SRAM size is 64 Kbit 4h = SRAM size is 128 Kbit 5h = SRAM size is 256 Kbit

Table 27. Memory_ID1 Register

Bit 7	Bit 6	Bit 5	Bit 4	Bit 3	Bit 2	Bit 1	Bit 0
not used (set to 0)	not used (set to 0)	B_type 1	B_type 0	B_size 3	B_size 2	B_size 1	B_size 0

Note: Bit Definitions:

B_size[3:0]	0h = There is no Secondary NVM 1h = Secondary NVM size is 128 Kbit 2h = Secondary NVM size is 256 Kbit 3h = Secondary NVM size is 512 Kbit
B_type[1:0]	0h = Secondary NVM is Flash memory 1h = Secondary NVM is EEPROM

DETAILED OPERATION

As shown in Figure 4, the PSD consists of six major types of functional blocks:

- Memory Blocks
- PLD Blocks
- MCU Bus Interface
- I/O Ports
- Power Management Unit (PMU)
- JTAG-ISP Interface

The functions of each block are described in the following sections. Many of the blocks perform multiple functions, and are user configurable.

Memory Blocks

The PSD has the following memory blocks:

- Primary Flash memory
- Secondary Flash memory
- SRAM

The Memory Select signals for these blocks originate from the Decode PLD (DPLD) and are user-defined in PSDsoft Express.

Table 28 summarizes the sizes and organizations of the memory blocks.

Table 28. Memory Block Size and Organization

Sector Number	Primary Flash Memory		Secondary Flash Memory		SRAM	
	Sector Size (x16)	Sector Select Signal	Sector Size (x16)	Sector Select Signal	SRAM Size (x16)	SRAM Select Signal
0	32K	FS0	4K	CSBOOT0	4K	RS0
1	32K	FS1	4K	CSBOOT1		
2	32K	FS2	4K	CSBOOT2		
3	32K	FS3	4K	CSBOOT3		
4	32K	FS4				
5	32K	FS5				
6	32K	FS6				
7	32K	FS7				
Totals	512KByte	8 Sectors	32KByte	4 Sectors	8KByte	

Primary Flash Memory and Secondary Flash memory Description. The primary Flash memory is divided evenly into 8 sectors. The secondary Flash memory is divided evenly into 4 sectors. Each sector of either memory block can be separately protected from Program and Erase cycles.

Flash memory may be erased on a sector-by-sector basis, and programmed word-by-word. Flash sector erasure may be suspended while data is read from other sectors of the block and then resumed after reading.

During a Program or Erase cycle in Flash memory, the status can be output on the Ready/Busy pin (PE4). This pin is set up using PSDsoft Express.

Memory Block Select Signals. The DPLD generates the Select signals for all the internal memory blocks (see the section entitled “PLDs”, on page 31). Each of the sectors of the primary Flash memory has a Select signal (FS0-FS7) which can contain up to three product terms. Each of the sectors of the secondary Flash memory has a Select signal (CSBOOT0-CSBOOT3) which can contain up to three product terms. Having three product terms for each Select signal allows a given sector to be mapped in different areas of system memory. When using a MCU with separate Program and Data space (80C51XA), these flexible Select signals allow dynamic re-mapping of sectors from one memory space to the other before and after IAP. The SRAM block has a single Select signal (RS0).

Ready/Busy (PE4). This signal can be used to output the Ready/Busy status of the PSD. The out-

put is a 0 (Busy) when a Flash memory block is being written to, *or* when a Flash memory block is being erased. The output is a 1 (Ready) when no Write or Erase cycle is in progress.

Memory Operation. The primary Flash memory and secondary Flash memory are addressed through the MCU Bus Interface. The MCU can access these memories in one of two ways:

- The MCU can execute a typical bus Write or Read *operation* just as it would if accessing a RAM or ROM device using standard bus cycles.
- The MCU can execute a specific instruction that consists of several Write and Read operations. This involves writing specific data patterns to special addresses within the Flash memory to invoke an embedded algorithm. These instructions are summarized in Table 29.

Typically, the MCU can read Flash memory using Read operations, just as it would read a ROM device. However, Flash memory can only be erased and programmed using specific instructions. For example, the MCU cannot write a single byte directly to Flash memory as one would write a byte to RAM. To program a word into Flash memory, the MCU must execute a Program instruction, then test the status of the Programming event. This status test is achieved by a Read operation or polling Ready/Busy (PE4).

Flash memory can also be read by using special instructions to retrieve particular Flash device information (sector protect status and ID).

Table 29. Instructions

Instruction ¹⁴	FS0-FS7 or CSBOOT0-CSBOOT3	Cycle 1	Cycle 2	Cycle 3	Cycle 4	Cycle 5	Cycle 6	Cycle 7
Read ⁵	1	“Read” RD @ RA						
Read Main Flash ID ⁶	1	AAh@ XAAAh	55h@ X554h	90h@ XAAAh	Read ID @ XX02h			
Read Sector Protection ^{6,8,13}	1	AAh@ XAAAh	55h@ X554h	90h@ XAAAh	Read 00h or 01h @ XX04h			
Program a Flash Word ¹³	1	AAh@ XAAAh	55h@ X554h	A0h@ XAAAh	PD@ PA			
Flash Sector Erase ^{7,13}	1	AAh@ XAAAh	55h@ X554h	80h@ XAAAh	AAh@ XAAAh	55h@ X554h	30h@ SA	30h ⁷ @ next SA
Flash Bulk Erase ¹³	1	AAh@ XAAAh	55h@ X554h	80h@ XAAAh	AAh@ XAAAh	55h@ X554h	10h@ XAAAh	
Suspend Sector Erase ¹¹	1	B0h@ XXXXh						
Resume Sector Erase ¹²	1	30h@ XXXXh						
Reset ⁶	1	F0h@ XXXXh						
Unlock Bypass	1	AAh@ XAAAh	55h@ X554h	20h@ XAAAh				
Unlock Bypass Program ⁹	1	A0h@ XXXXh	PD@ PA					
Unlock Bypass Reset ¹⁰	1	90h@ XXXXh	00h@ XXXXh					

- Note: 1. All bus cycles are write bus cycles, except the ones with the “Read” label
 2. All values are in hexadecimal:
 X = Don’t Care. Addresses of the form XXXXh, in this table, must be even addresses
 RA = Address of the memory location to be read
 RD = Data read from location RA during the Read cycle
 PA = Address of the memory location to be programmed. Addresses are latched on the falling edge of Write Strobe (\overline{WR} , CNTL0). PA is an even address for PSD in word programming mode.
 PD = Data word to be programmed at location PA. Data is latched on the rising edge of Write Strobe (\overline{WR} , CNTL0)
 SA = Address of the sector to be erased or verified. The Sector Select (FS0-FS7 or CSBOOT0-CSBOOT3) of the sector to be erased, or verified, must be Active (High).
 3. Sector Select (FS0 to FS7 or CSBOOT0 to CSBOOT3) signals are active High, and are defined in PSDsoft Express.
 4. Only address bits A11-A0 are used in instruction decoding.
 5. No Unlock or instruction cycles are required when the device is in the Read mode
 6. The Reset instruction is required to return to the Read mode after reading the Flash ID, or after reading the Sector Protection Status, or if the Error Flag (DQ5/DQ13) bit goes High.
 7. Additional sectors to be erased must be written at the end of the Sector Erase instruction within 80 μ s.
 8. The data is 00h for an unprotected sector, and 01h for a protected sector. In the fourth cycle, the Sector Select is active, and (A1,A0)=(1,0)
 9. The Unlock Bypass instruction is required prior to the Unlock Bypass Program instruction.
 10. The Unlock Bypass Reset Flash instruction is required to return to reading memory data when the device is in the Unlock Bypass mode.
 11. The system may perform Read and Program cycles in non-erasing sectors, read the Flash ID or read the Sector Protection Status when in the Suspend Sector Erase mode. The Suspend Sector Erase instruction is valid only during a Sector Erase cycle.
 12. The Resume Sector Erase instruction is valid only during the Suspend Sector Erase mode.
 13. The MCU cannot invoke these instructions while executing code from the same Flash memory as that for which the instruction is intended. The MCU must fetch, for example, the code from the secondary Flash memory when reading the Sector Protection Status of the primary Flash memory.
 14. All write bus cycles in an instruction are byte write to an even address (XA4Ah or X554h). A Flash memory Program bus cycle writes a word to an even address.



Instructions

An instruction consists of a sequence of specific operations. Each received byte is sequentially decoded by the PSD and not executed as a standard Write operation. The instruction is executed when the correct number of bytes are properly received and the time between two consecutive bytes is shorter than the time-out period. Some instructions are structured to include Read operations after the initial Write operations.

The instruction must be followed exactly. Any invalid combination of instruction bytes or time-out between two consecutive bytes while addressing Flash memory resets the device logic into Read mode (Flash memory is read like a ROM device).

The PSD supports the instructions summarized in Table 29:

- Erase memory by chip or sector
- Suspend or resume sector erase
- Program a Word
- Reset to Read mode
- Read primary Flash Identifier value
- Read Sector Protection Status
- Bypass

These instructions are detailed in Table 29. For efficient decoding of the instructions, the first two bytes of an instruction are the coded cycles and are followed by an instruction byte or confirmation byte. The coded cycles consist of writing the data AAh to address XAAAh during the first cycle and data 55h to address X554h during the second cycle (unless the Bypass instruction feature is used, as described later). Address signals A15-A12 are Don't Care during the instruction Write cycles. However, the appropriate Sector Select signal (FS0-FS7, or CSBOOT0-CSBOOT3) must be selected.

The primary and secondary Flash memories have the same instruction set (except for Read Primary Flash Identifier). The Sector Select signals determine which Flash memory is to receive and execute the instruction. The primary Flash memory is selected if any one of its Sector Select signals (FS0-FS7) is High, and the secondary Flash memory is selected if any one of its Sector Select signals (CSBOOT0-CSBOOT3) is High.

Power-up Condition. The PSD internal logic is reset upon Power-up to the Read mode. Sector Select (FS0-FS7 and CSBOOT0-CSBOOT3) must be held Low, and Write Strobe ($\overline{WR/WRL}$, CNTL0) High, during Power-up for maximum security of the data contents and to remove the possibility of data being written on the first edge of

Write Strobe ($\overline{WR/WRL}$, CNTL0). Any Write cycle initiation is locked when V_{CC} is below V_{LKO} .

Reading Flash Memory

Under typical conditions, the MCU may read the primary Flash memory, or secondary Flash memory, using Read operations just as it would a ROM or RAM device. Alternately, the MCU may use Read operations to obtain status information about a Program or Erase cycle that is currently in progress. Lastly, the MCU may use instructions to read special data from these memory blocks. The following sections describe these Read functions.

Read Memory Contents. Primary Flash memory and secondary Flash memory are placed in the Read mode after Power-up, chip reset, or a Reset Flash instruction (see Table 29). The MCU can read the memory contents of the primary Flash memory, or the secondary Flash memory by using Read operations any time the Read operation is not part of an instruction.

Read Primary Flash Identifier. The primary Flash memory identifier is read with an instruction composed of 4 operations: 3 specific Write operations and a Read operation (see Table 29). The identifier for the primary Flash memory is E8h. The secondary Flash memory does not support this instruction.

Read Memory Sector Protection Status. The Flash memory Sector Protection Status is read with an instruction composed of four operations: three specific Write operations and a Read operation (see Table 29). The Read operation produces 01h if the Flash memory sector is protected, or 00h if the sector is not protected.

The sector protection status for all NVM blocks (primary Flash memory, or secondary Flash memory) can be read by the MCU accessing the Flash Protection and Flash Boot Protection registers in PSD I/O space. See the section entitled "Flash Memory Sector Protect", on page 27, for register definitions.

Reading the Erase/Program Status Bits. The PSD provides several status bits to be used by the MCU to confirm the completion of an Erase or Program cycle of Flash memory. These status bits minimize the time that the MCU spends performing these tasks and are defined in Table 30. The status byte resides in an even location, and can be read as many times as needed. Also note that DQ15-DQ8 is an even byte for Motorola MCUs with a 16-bit data bus.

For Flash memory, the MCU can perform a Read operation to obtain these status bits while an Erase or Program instruction is being executed by the embedded algorithm. See the section entitled "Programming Flash Memory", on page 25, for details.

Table 30. Status Bits

DQ7	DQ6	DQ5	DQ4	DQ3	DQ2	DQ1	DQ0
Data Polling	Toggle Flag	Error Flag	X	Erase Time-out	X	X	X

Table 31. Status Bits for Motorola

DQ15	DQ14	DQ13	DQ12	DQ11	DQ10	DQ9	DQ8
Data Polling	Toggle Flag	Error Flag	X	Erase Time-out	X	X	X

Note: 1. X = Not guaranteed value, can be read either 1 or 0.
 2. DQ15-DQ0 represent the Data Bus bits, D15-D0.
 3. FS0-FS7/CSBOOT0-CSBOOT3 are active High.

Data Polling (DQ7) – DQ15 for Motorola.

When erasing or programming in Flash memory, the Data Polling (DQ7/DQ15) bit outputs the complement of the bit being entered for programming/writing on the DQ7/DQ15 bit. Once the Program instruction or the Write operation is completed, the true logic value is read on the Data Polling (DQ7/DQ15) bit (in a Read operation).

- Data Polling is effective after the fourth Write pulse (for a Program instruction) or after the sixth Write pulse (for an Erase instruction). It must be performed at the address being programmed or at an address within the Flash memory sector being erased.
- During an Erase cycle, the Data Polling (DQ7/DQ15) bit outputs a 0. After completion of the cycle, the Data Polling (DQ7/DQ15) bit outputs the last bit programmed (it is a 1 after erasing).
- If the location to be programmed is in a protected Flash memory sector, the instruction is ignored.
- If all the Flash memory sectors to be erased are protected, the Data Polling (DQ7/DQ15) bit is reset to 0 for about 100 μs, and then returns to the value from the previously addressed location. No erasure is performed.

Toggle Flag (DQ6) – DQ14 for Motorola. The PSD offers another way for determining when the Flash memory Program cycle is completed. During the internal Write operation and when either FS0-FS7 or CSBOOT0-CSBOOT3 is true, the Toggle Flag (DQ6/DQ14) bit toggles from 0 to 1 and 1 to 0 on subsequent attempts to read any word of the memory.

When the internal cycle is complete, the toggling stops and the data read on the Data Bus D0-D7 is the value from the addressed memory location. The device is now accessible for a new Read or

Write operation. The cycle is finished when two successive Reads yield the same output data.

- The Toggle Flag (DQ6/DQ14) bit is effective after the fourth Write pulse (for a Program instruction) or after the sixth Write pulse (for an Erase instruction).
- If the location to be programmed belongs to a protected Flash memory sector, the instruction is ignored.
- If all the Flash memory sectors selected for erasure are protected, the Toggle Flag (DQ6/DQ14) bit toggles to 0 for about 100 μs and then returns to the value from the previously addressed location.

Error Flag (DQ5) – DQ13 for Motorola. During a normal Program or Erase cycle, the Error Flag (DQ5/DQ13) bit is reset to 0. This bit is set to 1 when there is a failure during a Flash memory Program, Sector Erase, or Bulk Erase cycle.

In the case of Flash memory programming, the Error Flag (DQ5/DQ13) bit indicates the attempt to program a Flash memory bit, or bits, from the programmed state, 0, to the erased state, 1, which is not a valid operation. The Error Flag (DQ5/DQ13) bit may also indicate a Time-out condition while attempting to program a word.

In case of an error in a Flash memory Sector Erase or Word Program cycle, the Flash memory sector in which the error occurred or to which the programmed location belongs must no longer be used. Other Flash memory sectors may still be used. The Error Flag (DQ5/DQ13) bit is reset after a Reset instruction. A Reset instruction is required after detecting an error on the Error Flag (DQ5/DQ13) bit.

Erase Time-out Flag (DQ3) – DQ11 for Motorola. The Erase Time-out Flag (DQ3/DQ11) bit reflects the time-out period allowed between two consecutive Sector Erase instructions. The Erase Time-out Flag (DQ3/DQ11) bit is reset to 0 after a

Sector Erase cycle for a period of 100 μ s + 20% unless an additional Sector Erase instruction is decoded. After this period, or when the additional Sector Erase instruction is decoded, the Erase Time-out Flag (DQ3/DQ11) bit is set to 1.

Programming Flash Memory

Flash memory must be erased prior to being programmed. The MCU may erase Flash memory all at once or by-sector. Although erasing Flash memory occurs on a sector or device basis, programming Flash memory occurs on a word basis.

The primary and secondary Flash memories require the MCU to send an instruction to program a word or to erase sectors (see Table 29).

Once the MCU issues a Flash memory Program or Erase instruction, it must check the status bits for completion. The embedded algorithms that are invoked inside the PSD support several means to provide status to the MCU. Status may be checked using any of three methods: Data Polling, Data Toggle, or Ready/Busy (PE4) signal.

Data Polling. Polling on the Data Polling (DQ7/DQ15) bit is a method of checking whether a Program or Erase cycle is in progress or has completed. Figure 6 shows the Data Polling algorithm.

When the MCU issues a Program instruction, the embedded algorithm within the PSD begins. The MCU then reads the location of the word to be programmed in Flash memory to check the status. The Data Polling (DQ7/DQ15) bit becomes the complement of the corresponding bit of the original data word to be programmed. The MCU continues to poll this location, comparing data and monitoring the Error Flag (DQ5/DQ13) bit. When the Data Polling (DQ7/DQ15) bit matches the corresponding bit of the original data, and the Error Flag (DQ5/DQ13) bit remains 0, the embedded algorithm is complete. If the Error Flag (DQ5/DQ13) bit is 1, the MCU should test the Data Polling (DQ7/DQ15) bit again since the Data Polling (DQ7/DQ15) bit may have changed simultaneously with the Error Flag (DQ5/DQ13) bit (see Figure 6).

The Error Flag (DQ5/DQ13) bit is set if either an internal time-out occurred while the embedded algorithm attempted to program the location or if the MCU attempted to program a 1 to a bit that was not erased (not erased is logic 0).

It is suggested (as with all Flash memories) to read the location again after the embedded programming algorithm has completed, to compare the word that was written to the Flash memory with the word that was intended to be written.

When using the Data Polling method during an Erase cycle, Figure 6 still applies. However, the Data Polling (DQ7/DQ15) bit is 0 until the Erase cycle is complete. A 1 on the Error Flag (DQ5/DQ13) bit indicates a time-out condition on the

Erase cycle, a 0 indicates no error. The MCU can read any even location within the sector being erased to get the Data Polling (DQ7/DQ15) bit and the Error Flag (DQ5/DQ13) bit.

PSDsoft Express generates ANSI C code functions that implement these Data Polling algorithms.

Figure 6. Data Polling Flowchart

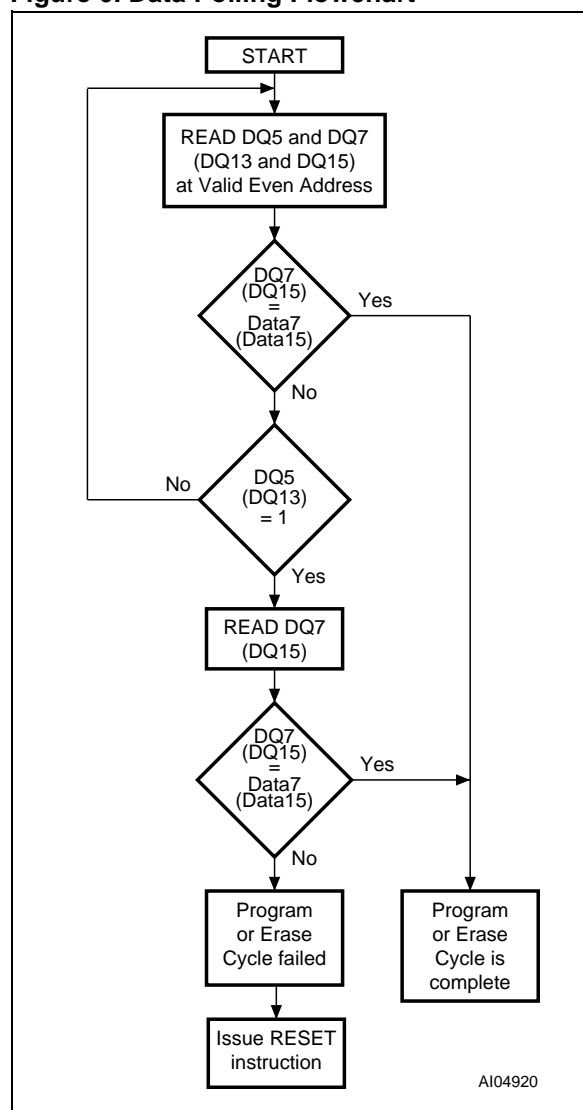

Data Toggle. Checking the Toggle Flag (DQ6/DQ14) bit is another method of determining whether a Program or Erase cycle is in progress or has completed. Figure 7 shows the Data Toggle algorithm.

When the MCU issues a Program instruction, the embedded algorithm within the PSD begins. The MCU then reads the location to be programmed in Flash memory to check the status. The Toggle Flag (DQ6/DQ14) bit toggles each time the MCU

reads this location until the embedded algorithm is complete. The MCU continues to read this location, checking the Toggle Flag (DQ6/DQ14) bit and monitoring the Error Flag (DQ5/DQ13) bit. When the Toggle Flag (DQ6/DQ14) bit stops toggling (two consecutive reads yield the same value), and the Error Flag (DQ5/DQ13) bit remains 0, the embedded algorithm is complete. If the Error Flag (DQ5/DQ13) bit is 1, the MCU should test the Toggle Flag (DQ6/DQ14) bit again, since the Toggle Flag (DQ6/DQ14) bit may have changed simultaneously with the Error Flag (DQ5/DQ13) bit (see Figure 7).

Figure 7. Data Toggle Flowchart

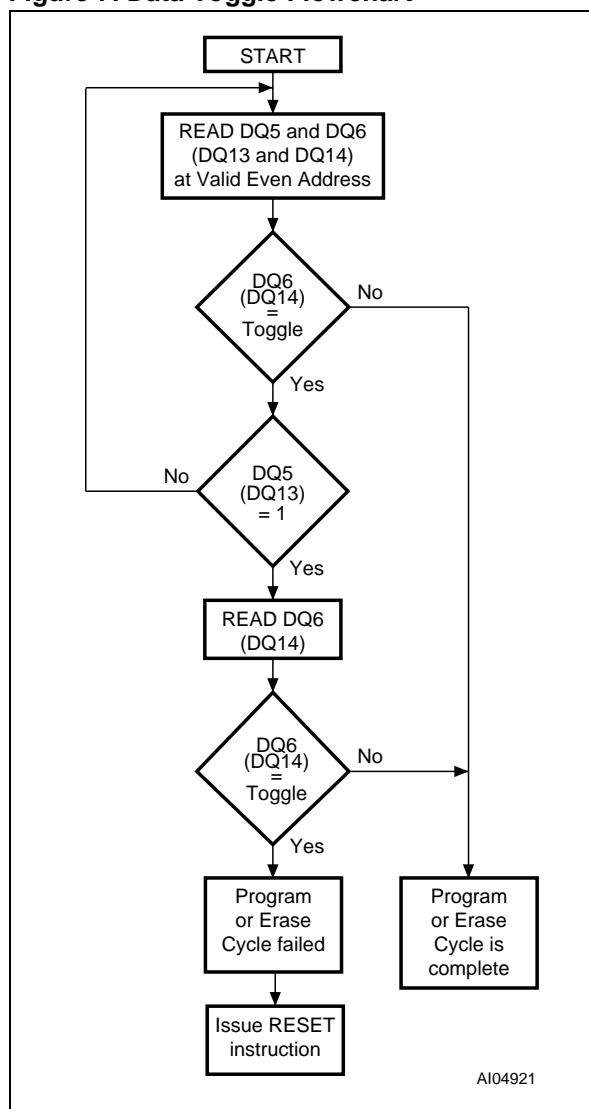

The Error Flag (DQ5/DQ13) bit is set if either an internal time-out occurred while the embedded algorithm attempted to program, or if the MCU

attempted to program a 1 to a bit that was not erased (not erased is logic 0).

It is suggested (as with all Flash memories) to read the location again after the embedded programming algorithm has completed, to compare the word that was written to Flash memory with the word that was intended to be written.

When using the Data Toggle method after an Erase cycle, Figure 7 still applies. the Toggle Flag (DQ6/DQ14) bit toggles until the Erase cycle is complete. A 1 on the Error Flag (DQ5/DQ13) bit indicates a time-out condition on the Erase cycle, a 0 indicates no error. The MCU can read any even location within the sector being erased to get the Toggle Flag (DQ6/DQ14) bit and the Error Flag (DQ5/DQ13) bit.

PSDsoft Express generates ANSI C code functions which implement these Data Toggling algorithms.

Unlock Bypass. The Unlock Bypass instruction allows the system to program words to the Flash memories faster than using the standard Program instruction. The Unlock Bypass mode is entered by first initiating two Unlock cycles. This is followed by a third Write cycle containing the Unlock Bypass command, 20h (as shown in Table 29). The Flash memory then enters the Unlock Bypass mode.

A two-cycle Unlock Bypass Program instruction is all that is required to program in this mode. The first cycle in this instruction contains the Unlock Bypass Program command, A0h. The second cycle contains the program address and data. Additional data is programmed in the same manner. This mode dispense with the initial two Unlock cycles required in the standard Program instruction, resulting in faster total programming time.

During the unlock bypass mode, only the Unlock Bypass Program and Unlock Bypass Reset instructions are valid.

To exit the Unlock Bypass mode, the system must issue the two-cycle Unlock Bypass Reset instruction. The first cycle must contain the data 90h; the second cycle the data 00h. Addresses are Don't Care for both cycles. The Flash memory then returns to Read mode.

Erasing Flash Memory

Flash Bulk Erase. The Flash Bulk Erase instruction uses six Write operations followed by a Read operation of the status register, as described in Table 29. If any byte of the Bulk Erase instruction is wrong, the Bulk Erase instruction aborts and the device is reset to the Read Memory mode.

During a Bulk Erase, the memory status may be checked by reading the Error Flag (DQ5/DQ13) bit, the Toggle Flag (DQ6/DQ14) bit, and the Data Polling (DQ7/DQ15) bit, as detailed in the section



entitled “Programming Flash Memory”, on page 25. The Error Flag (DQ5/DQ13) bit returns a 1 if there has been an Erase Failure (maximum number of Erase cycles have been executed).

It is not necessary to program the memory with 00h because the PSD automatically does this before erasing to 0FFh.

During execution of the Bulk Erase instruction, the Flash memory does not accept any instructions.

Flash Sector Erase. The Sector Erase instruction uses six Write operations, as described in Table 29. Additional Flash Sector Erase confirm commands and Flash memory sector addresses can be written subsequently to erase other Flash memory sectors in parallel, without further coded cycles, if the additional commands are transmitted in a shorter time than the time-out period of about 100 μ s. The input of a new Sector Erase command restarts the time-out period.

The status of the internal timer can be monitored through the level of the Erase Time-out Flag (DQ3/DQ11) bit. If the Erase Time-out Flag (DQ3/DQ11) bit is 0, the Sector Erase instruction has been received and the time-out period is counting. If the Erase Time-out Flag (DQ3/DQ11) bit is 1, the time-out period has expired and the PSD is busy erasing the Flash memory sector(s). Before and during Erase time-out, any instruction other than Suspend Sector Erase and Resume Sector Erase, abort the cycle that is currently in progress, and reset the device to Read mode. It is not necessary to program the Flash memory sector with 00h as the PSD does this automatically before erasing.

During a Sector Erase, the memory status may be checked by reading the Error Flag (DQ5/DQ13) bit, the Toggle Flag (DQ6/DQ14) bit, and the Data Polling (DQ7/DQ15) bit, as detailed in the section entitled “Programming Flash Memory”, on page 25.

During execution of the Erase cycle, the Flash memory accepts only Reset and Suspend Sector Erase instructions. Erasure of one Flash memory sector may be suspended, in order to read data from another Flash memory sector, and then resumed.

Suspend Sector Erase. When a Sector Erase cycle is in progress, the Suspend Sector Erase instruction can be used to suspend the cycle by writing 0B0h to any even address when an appropriate Sector Select (FS0-FS7 or CSBOOT0-CSBOOT3) is High. (See Table 29). This allows reading of data from another Flash memory sector after the Erase cycle has been suspended. Suspend Sector Erase is accepted only during the Flash Sector Erase instruction execution and defaults to Read mode. A Suspend Sector Erase instruction executed during an Erase

time-out period, in addition to suspending the Erase cycle, terminates the time out period.

The Toggle Flag (DQ6/DQ14) bit stops toggling when the PSD internal logic is suspended. The status of this bit must be monitored at an address within the Flash memory sector being erased. The Toggle Flag (DQ6/DQ14) bit stops toggling between 0.1 μ s and 15 μ s after the Suspend Sector Erase instruction has been executed. The PSD is then automatically set to Read mode.

If an Suspend Sector Erase instruction was executed, the following rules apply:

- Attempting to read from a Flash memory sector that was being erased outputs invalid data.
- Reading from a Flash memory sector that was *not* being erased is valid.
- The Flash memory *cannot* be programmed, and only responds to Resume Sector Erase and Reset instructions (Read is an operation and is allowed).
- If a Reset instruction is received, data in the Flash memory sector that was being erased is invalid.

Resume Sector Erase. If a Suspend Sector Erase instruction was previously executed, the Erase cycle may be resumed with this instruction. The Resume Sector Erase instruction consists of writing 030h to any even address while an appropriate Sector Select (FS0-FS7 or CSBOOT0-CSBOOT3) is High. (See Table 29.)

Flash Memory Sector Protect

Each sector of Primary or Secondary Flash memory can be separately protected against Program and Erase cycles. Sector Protection provides additional data security because it disables all Program or Erase cycles. This mode can be activated (or deactivated) through the JTAG-ISP Port or a Device Programmer.

Sector protection can be selected for each sector using the PSDsoft Express program. This automatically protects selected sectors when the device is programmed through the JTAG Port or a Device Programmer. Flash memory sectors can be unprotected to allow updating of their contents using the JTAG Port or a Device Programmer. The MCU can read (but cannot change) the sector protection bits.

Any attempt to program or erase a protected Flash memory sector is ignored by the device. The Verify operation results in a read of the protected data. This allows a guarantee of the retention of the Protection status.

The sector protection status can be read by the MCU through the Flash memory protection and Secondary Flash memory protection registers (in

the CSIOP block) or use the Read Sector Protection instruction. See Table 19 to Table 20.

Reset

The Reset instruction consists of one Write cycle (see Table 29). It can also be optionally preceded by the standard two write decoding cycles (writing AAh to AAAh, and 55h to 554h).

The Reset instruction must be executed after:

- Reading the Flash Protection Status or Flash ID
- An Error condition has occurred (and the device has set the Error Flag (DQ5/DQ13) bit to 1) during a Flash memory Program or Erase cycle.

The Reset instruction immediately puts the Flash memory back into normal Read mode. However, if there is an error condition (with the Error Flag (DQ5/DQ13) bit set to 1) the Flash memory will return to the Read mode in 25 μs after the Reset instruction is issued.

The Reset instruction is ignored when it is issued during a Program or Bulk Erase cycle of the Flash memory. The Reset instruction aborts any on-going Sector Erase cycle, and returns the Flash memory to the normal Read mode in 25 μs.

Reset (RESET) Pin. A pulse on the Reset (RESET) pin aborts any cycle that is in progress, and resets the Flash memory to the Read mode. When the reset occurs during a Program or Erase cycle, the Flash memory takes up to 25 μs to return to the Read mode. It is recommended that the Reset (RESET) pulse (except for Power On Reset, as described on page 62) be at least 25 μs so that the Flash memory is always ready for the MCU to fetch the bootstrap instructions after the Reset cycle is complete.

SRAM

The SRAM is enabled when SRAM Select (RS0) from the DPLD is High. SRAM Select (RS0) can contain up to three product terms, allowing flexible memory mapping.

The SRAM can be backed up using an external battery. The external battery should be connected to the Voltage Stand-by (VSTBY, PE6) line. If you have an external battery connected to the PSD, the contents of the SRAM are retained in the event of a power loss. The contents of the SRAM are retained so long as the battery voltage remains at 2 V or greater. If the supply voltage falls below the battery voltage, an internal power switch-over to the battery occurs.

PE7 can be configured as an output that indicates when power is being drawn from the external battery. This Battery-on Indicator (VBATON, PE7) signal is High when the supply voltage falls below the battery voltage and the battery on Voltage Stand-by (VSTBY, PE6) is supplying power to the internal SRAM.

SRAM Select (RS0), Voltage Stand-by (VSTBY, PE6) and Battery-on Indicator (VBATON, PE7) are all configured using PSDsoft Express.

Memory Select Signals

The Primary Flash Memory Sector Select (FS0-FS7), Secondary Flash Memory Sector Select (CSBOOT0-CSBOOT3) and SRAM Select (RS0) signals are all outputs of the DPLD. They are defined using PSDsoft Express. The following rules apply to the equations for these signals:

1. Primary Flash memory and secondary Flash memory Sector Select signals must *not* be larger than the physical sector size.
2. Any primary Flash memory sector must *not* be mapped in the same memory space as another Flash memory sector.
3. A secondary Flash memory sector must *not* be mapped in the same memory space as another secondary Flash memory sector.
4. SRAM, I/O, and Peripheral I/O spaces must *not* overlap.
5. A secondary Flash memory sector *may* overlap a primary Flash memory sector. In case of overlap, priority is given to the secondary Flash memory sector.
6. SRAM, I/O, and Peripheral I/O spaces *may* overlap any other memory sector. Priority is given to the SRAM, I/O, or Peripheral I/O.

Figure 8. Priority Level of Memory and I/O Components

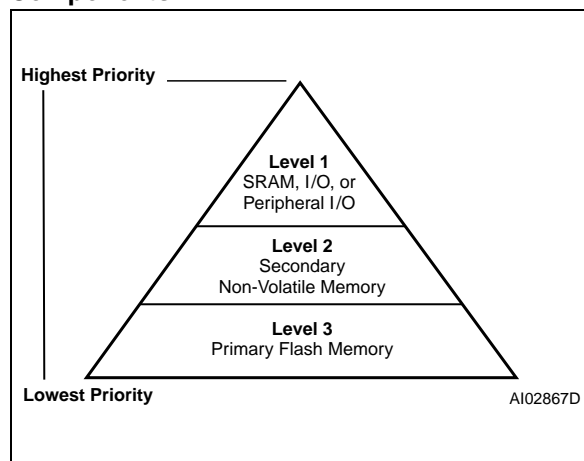

Example. FS0 is valid when the address is in the range of 8000h to BFFFh, CSBOOT0 is valid from 8000h to 9FFFh, and RS0 is valid from 8000h to 87FFh. Any address in the range of RS0 always accesses the SRAM. Any address in the range of CSBOOT0 greater than 87FFh (and less than 9FFFh) automatically addresses secondary Flash memory segment 0. Any address greater than 9FFFh accesses the primary Flash memory seg-



ment 0. You can see that half of the primary Flash memory segment 0 and one-fourth of secondary Flash memory segment 0 cannot be accessed in this example. Also note that an equation that defined FS1 to anywhere in the range of 8000h to BFFFh would *not* be valid.

Figure 8 shows the priority levels for all memory components. Any component on a higher level can overlap and has priority over any component on a lower level. Components on the same level must *not* overlap. Level 1 has the highest priority and level 3 has the lowest.

Memory Select Configuration for MCUs with Separate Program and Data Spaces. The 80C51XA and compatible family of MCUs, can be configured to have separate address spaces for Program memory (selected using Program Select Enable ($\overline{\text{PSEN}}$, CNTL2)) and Data memory (selected using Read Strobe ($\overline{\text{RD}}$, CNTL1)). Any of the memories within the PSD can reside in either space or both spaces. This is controlled through manipulation of the VM register that resides in the CSIOP space.

The VM register is set using PSDsoft Express to have an initial value. It can subsequently be changed by the MCU so that memory mapping can be changed on-the-fly.

For example, you may wish to have SRAM and primary Flash memory in the Data space at Boot-up, and secondary Flash memory in the Program space at Boot-up, and later swap the secondary Flash memory and primary Flash memory. This is easily done with the VM register by using PSDsoft Express to configure it for Boot-up and having the MCU change it when desired.

Table 25 describes the VM Register.

Separate Space Modes. Program space is separated from Data space. For example, Program Select Enable ($\overline{\text{PSEN}}$, CNTL2) is used to access the program code from the primary Flash memory, while Read Strobe ($\overline{\text{RD}}$, CNTL1) is used to access data from the secondary Flash memory, SRAM and I/O Port blocks. This configuration requires the VM register to be set to 0Ch (see Figure 9).

Figure 9. 8031 Memory Modules – Separate Space

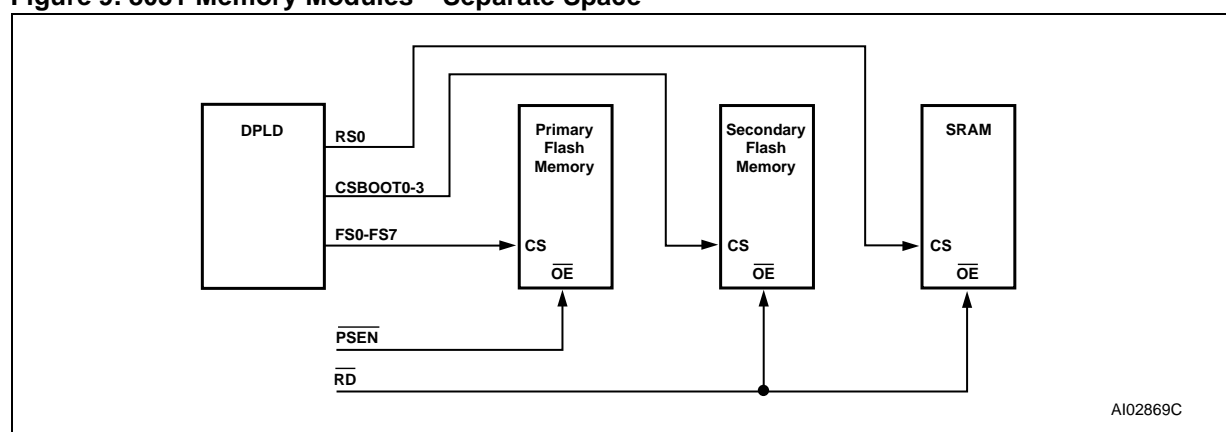

Combined Space Modes. The Program and Data spaces are combined into one memory space that allows the primary Flash memory, secondary Flash memory, and SRAM to be accessed by either Program Select Enable ($\overline{\text{PSEN}}$, CNTL2) or Read Strobe ($\overline{\text{RD}}$, CNTL1). For example, to

configure the primary Flash memory in Combined space, bits 2 and 4 of the VM register are set to 1 (see Figure 10).

80C51XA Memory Map Example. See the Application Notes for examples.

Figure 10. 8031 Memory Modules – Combined Space

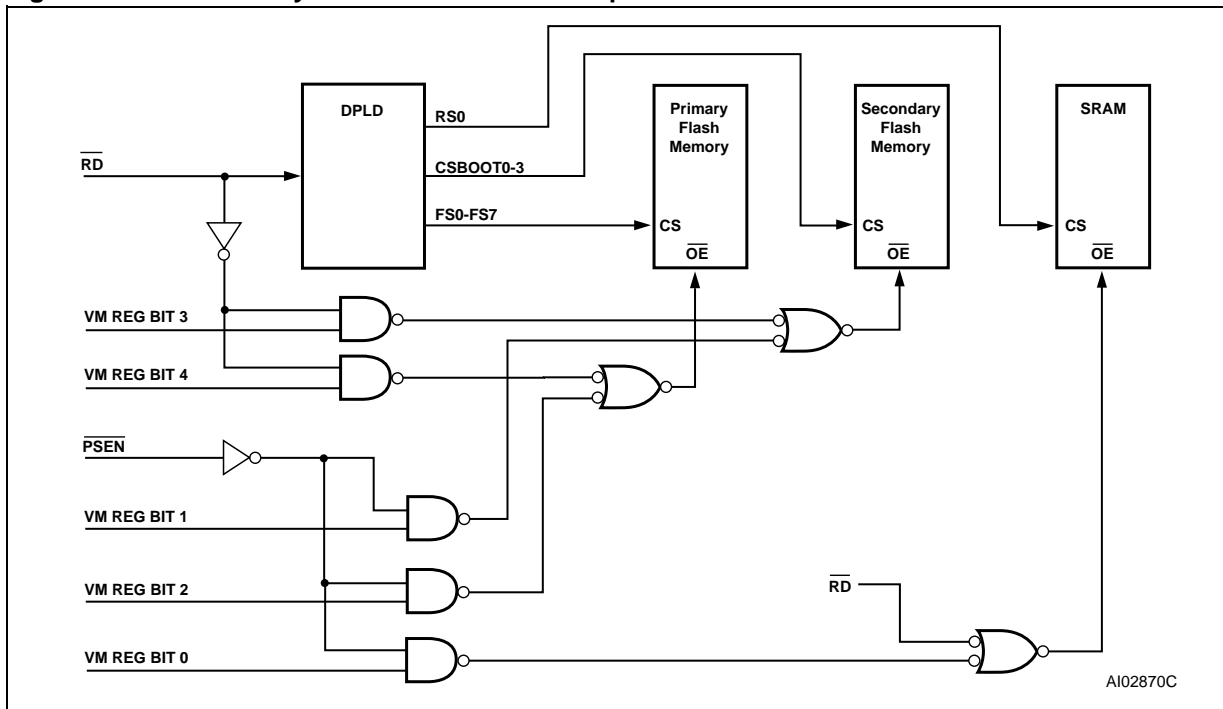

Page Register

The 8-bit Page Register increases the addressing capability of the MCU by a factor of up to 256. The contents of the register can also be read by the MCU. The outputs of the Page Register (PGR0-PGR7) are inputs to the DPLD decoder and can be included in the Sector Select (FS0-FS7, CSBOOT0-CSBOOT3), and SRAM Select (RS0) equations.

If memory paging is not needed, or if not all eight page register bits are needed for memory paging, these bits may be used in the CPLD for general logic. See Application Note AN1154.

Table 22 and Figure 11 show the Page Register. The eight flip-flops in the register are connected to the internal data bus (D0-D7). The MCU can write to or read from the Page Register. The Page Register can be accessed at address location CSIOP + E0h.

Figure 11. Page Register

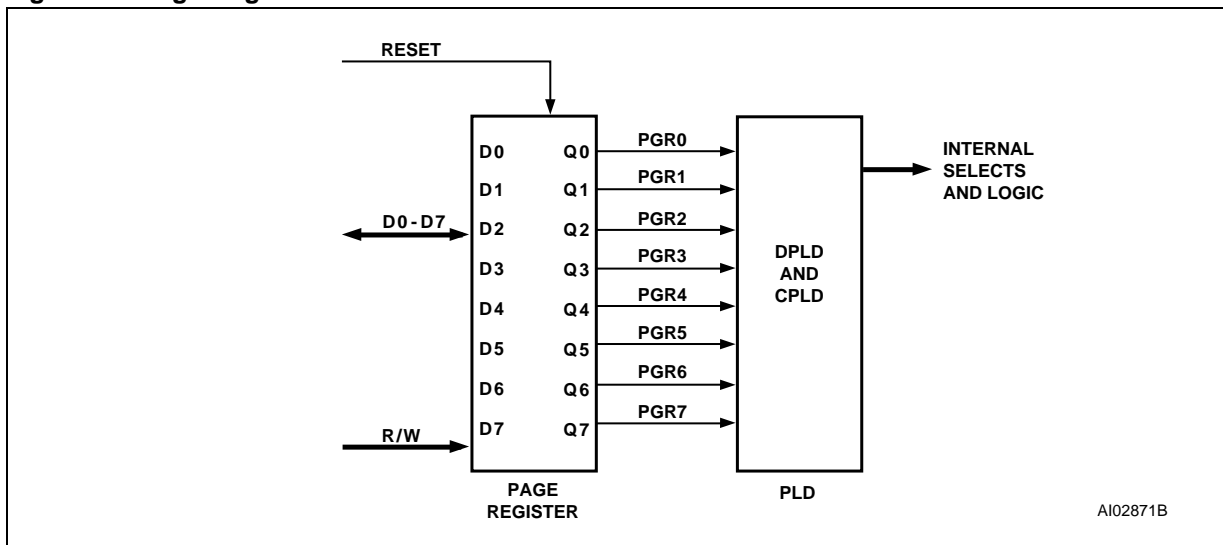

Memory ID Registers

The 8-bit read-only Memory Status Registers are included in the CSIOP space. The user can determine the memory configuration of the PSD device by reading the Memory ID0 and Memory ID1 registers. The content of the registers is defined as shown in Table 26 and Table 27.

PLDs

The PLDs bring programmable logic functionality to the PSD. After specifying the logic for the PLDs using PSDsoft Express, the logic is programmed into the device and available upon Power-up.

Table 32. DPLD and CPLD Inputs

Input Source	Input Name	Number of Signals
MCU Address Bus ¹	A15-A0	16
MCU Control Signals	CNTL0-CNTL2	3
Reset	$\overline{\text{RST}}$	1
Power-down	PDN	1
Port A Input Macrocells	PA7-PA0	8
Port B Input Macrocells	PB7-PB0	8
Port C Input Macrocells	PC7-PC0	8
Port D Inputs	PD3-PD0	4
Port F Inputs	PF7-PF0	8
Page Register	PGR7-PGR0	8
Macrocell A Feedback	MCELLA.FB7-FB0	8
Macrocell B Feedback	MCELLB.FB7-FB0	8
Flash memory Program Status Bit	Ready/ $\overline{\text{Busy}}$	1

Note: 1. The address inputs are A19-A4 in 80C51XA mode.

The PSD contains two PLDs: the Decode PLD (DPLD), and the Complex PLD (CPLD). The PLDs are briefly discussed in the next few paragraphs, and in more detail in the following sections. Figure 12 shows the configuration of the PLDs.

The DPLD performs address decoding for internal components, such as memory, registers, and I/O ports Select signals.

The CPLD can be used for logic functions, such as loadable counters and shift registers, state machines, and encoding and decoding logic. These logic functions can be constructed using the 16 Output Macrocells (OMC), 24 Input Macrocells (IMC), and the AND Array. The CPLD can also be used to generate External Chip Select (ECS0-ECS2) signals.

The AND Array is used to form product terms. These product terms are specified using PSDsoft Express. An Input Bus consisting of 82 signals is connected to the PLDs. The signals are shown in Table 32.

The Turbo Bit in PSD. The PLDs in the PSD4235G2 can minimize power consumption by switching to standby when inputs remain unchanged for an extended time of about 70 ns. Resetting the Turbo bit to 0 (Bit 3 of the PMMR0 register) automatically places the PLDs into standby if no inputs are changing. Turning the Turbo mode off increases propagation delays while reducing power consumption. See the section entitled "Power Management", on page 59, on how to set the Turbo bit.

Additionally, five bits are available in the PMMR2 register to block MCU control signals from entering the PLDs. This reduces power consumption and can be used only when these MCU control signals are not used in PLD logic equations.

Each of the two PLDs has unique characteristics suited for its applications. They are described in the following sections.

Figure 12. PLD Diagram

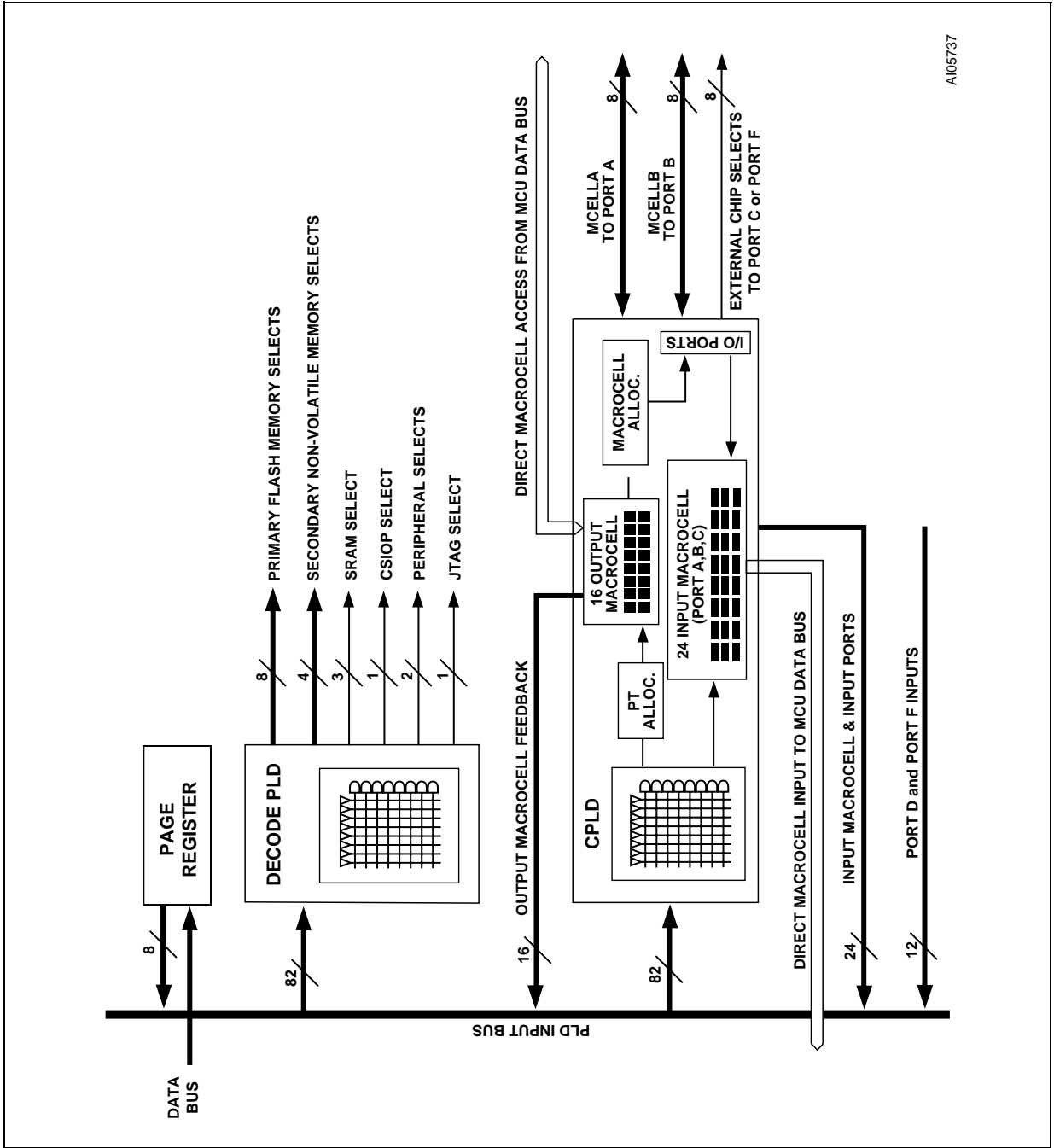

A105737

DECODE PLD (DPLD)

The DPLD, shown in Figure 13, is used for decoding the address for internal and external components. The DPLD can be used to generate the following decode signals:

- 8 Sector Select (FS0-FS7) signals for the primary Flash memory (three product terms each)
- 4 Sector Select (CSBOOT0-CSBOOT3) signals for the secondary Flash memory (three product terms each)
- 1 internal SRAM Select (RS0) signal (three product terms)
- 1 internal CSIOP Select (PSD Configuration Register) signal
- 1 JTAG Select signal (enables JTAG-ISP on Port E)
- 2 internal Peripheral Select signals (Peripheral I/O mode).

Figure 13. DPLD Logic Array

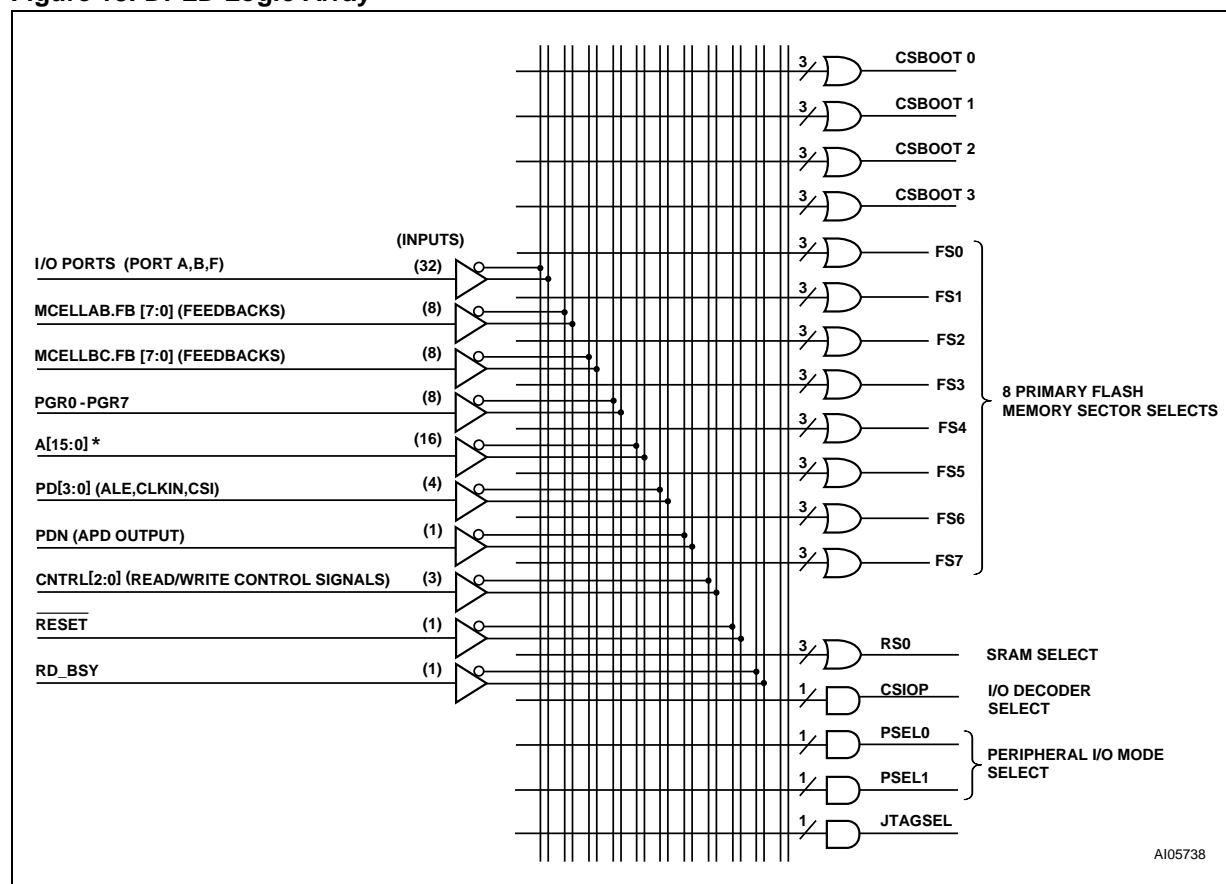

- Note: 1. The address inputs are A19-A4 when in 80C51XA mode
 2. Additional address lines can be brought into the PSD via Port A, B, C, D, or F.

COMPLEX PLD (CPLD)

The CPLD can be used to implement system logic functions, such as loadable counters and shift registers, system mailboxes, handshaking protocols, state machines, and random logic. The CPLD can also be used to generate eight External Chip Select (ECS0-ECS7), routed to Port C or Port F.

Although External Chip Select (ECS0-ECS7) can be produced by any Output Macrocell (OMC), these eight External Chip Select (ECS0-ECS7) on Port C or Port F do not consume any Output Macrocells (OMC).

As shown in Figure 12, the CPLD has the following blocks:

- 24 Input Macrocells (IMC)
- 16 Output Macrocells (OMC)
- Product Term Allocator

- AND Array capable of generating up to 196 product terms
- Four I/O Ports.

Each of the blocks are described in the sections that follow.

The Input Macrocells (IMC) and Output Macrocells (OMC) are connected to the PSD internal data bus and can be directly accessed by the MCU. This enables the MCU software to load data into the Output Macrocells (OMC) or read data from both the Input and Output Macrocells (IMC and OMC).

This feature allows efficient implementation of system logic and eliminates the need to connect the data bus to the AND Array as required in most standard PLD macrocell architectures.

Figure 14. Macrocell and I/O Port

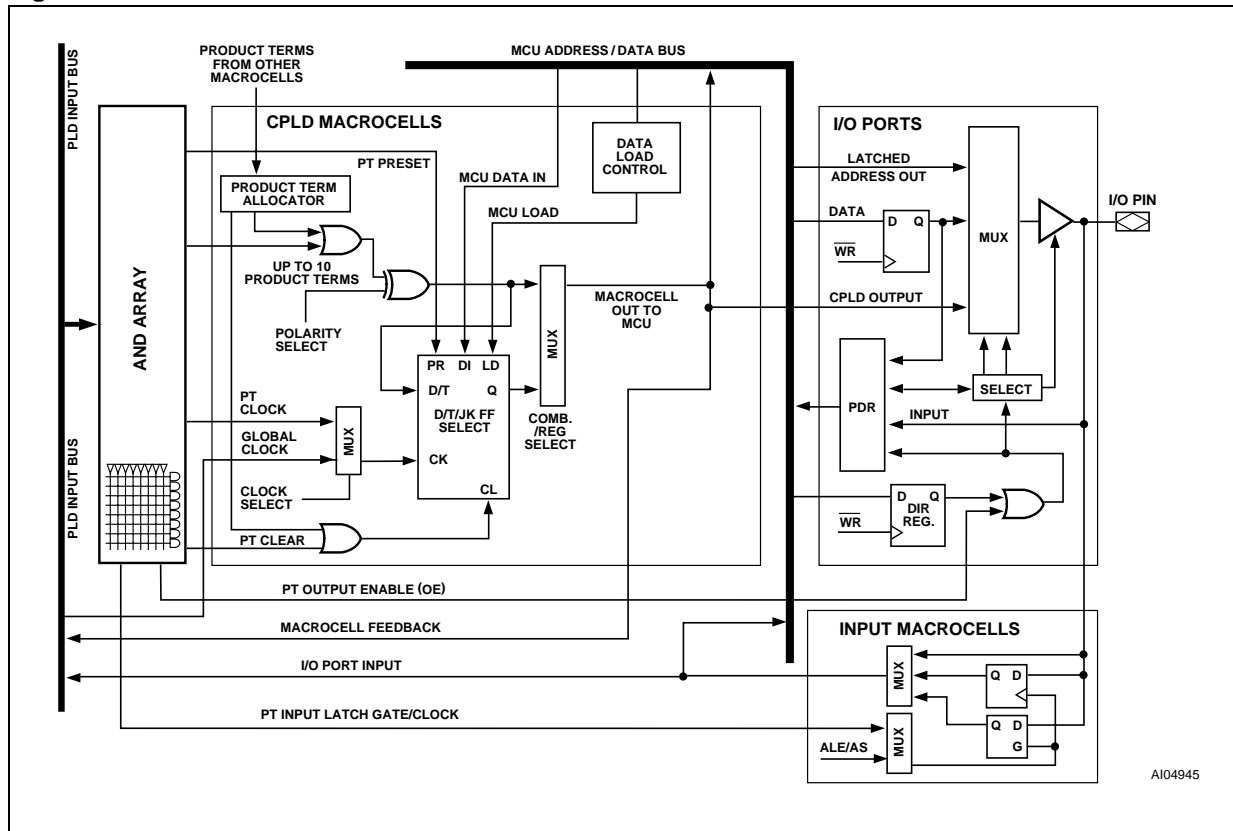

Output Macrocell (OMC). Eight of the Output Macrocells (OMC) are connected to Ports A pins and are named as McellA0-McellA7. The other eight Macrocells are connected to Ports B pins and are named as McellB0-McellB7.

The Output Macrocell (OMC) architecture is shown in Figure 15. As shown in the figure, there are native product terms available from the AND Array, and borrowed product terms available (if unused) from other Output Macrocells (OMC). The polarity of the product term is controlled by the XOR gate. The Output Macrocell (OMC) can implement either sequential logic, using the flip-flop element, or combinatorial logic. The multiplexer selects between the sequential or combinatorial logic outputs. The multiplexer output can drive a

port pin and has a feedback path to the AND Array inputs.

The flip-flop in the Output Macrocell (OMC) block can be configured as a D, T, JK, or SR type in the PSDsoft Express program. The flip-flop's clock, preset, and clear inputs may be driven from a product term of the AND Array. Alternatively, the external CLKIN (PD1) signal can be used for the clock input to the flip-flop. The flip-flop is clocked on the rising edge of CLKIN (PD1). The preset and clear are active High inputs. Each clear input can use up to two product terms.

Table 33. Output Macrocell Port and Data Bit Assignments

Output Macrocell	Port Assignment	Native Product Terms	Maximum Borrowed Product Terms	Data Bit for Loading or Reading	Motorola 16-Bit MCU for Loading or Reading
McellA0	Port A0	3	6	D0	D8
McellA1	Port A1	3	6	D1	D9
McellA2	Port A2	3	6	D2	D10
McellA3	Port A3	3	6	D3	D11
McellA4	Port A4	3	6	D4	D12
McellA5	Port A5	3	6	D5	D13
McellA6	Port A6	3	6	D6	D14
McellA7	Port A7	3	6	D7	D15
McellB0	Port B0	4	5	D8	D0
McellB1	Port B1	4	5	D9	D1
McellB2	Port B2	4	5	D10	D2
McellB3	Port B3	4	5	D11	D3
McellB4	Port B4	4	6	D12	D4
McellB5	Port B5	4	6	D13	D5
McellB6	Port B6	4	6	D14	D6
McellB7	Port B7	4	6	D15	D7

Figure 15. CPLD Output Macrocell

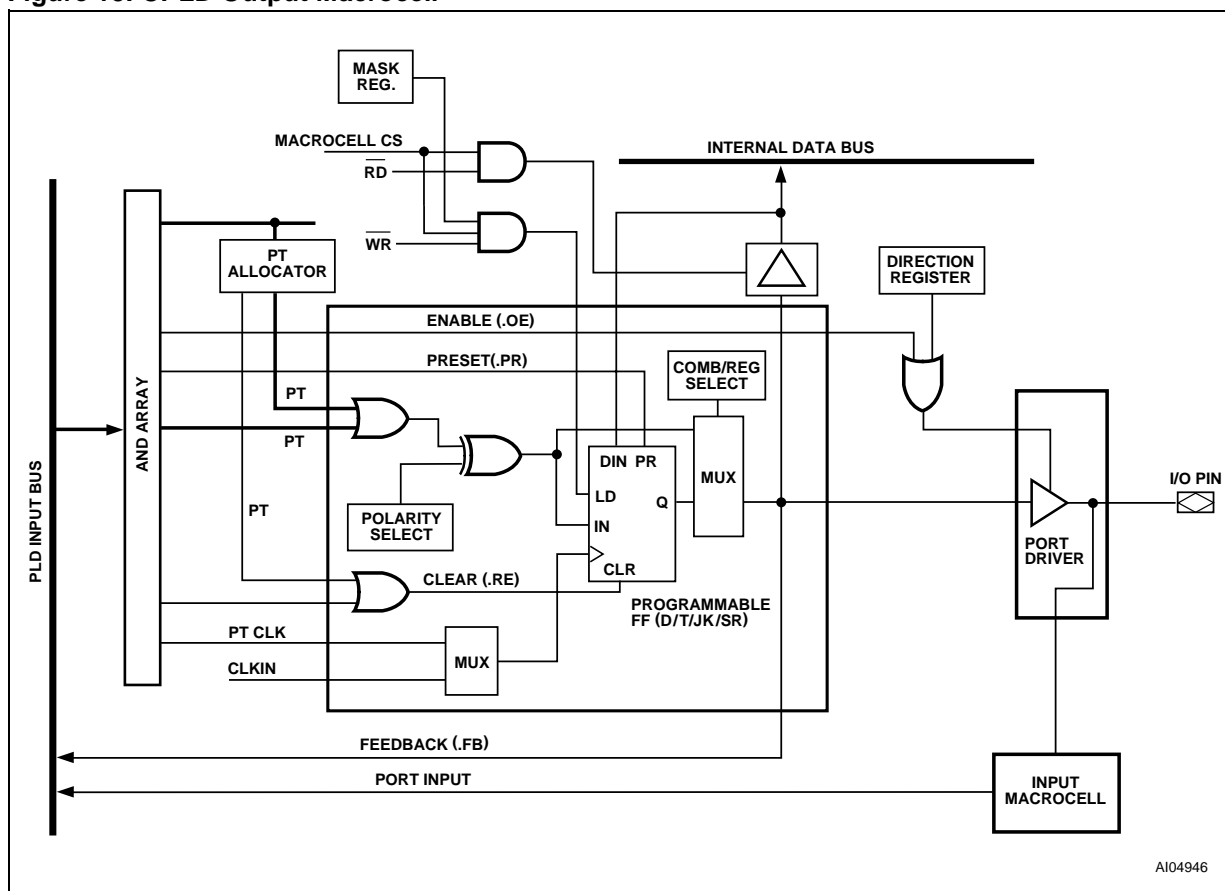

AI04946

Product Term Allocator. The CPLD has a Product Term Allocator. PSDsoft Express, uses the Product Term Allocator to borrow and place product terms from one Macrocell to another. The following list summarizes how product terms are allocated:

- McellA0-McellA7 all have three native product terms and may borrow up to six more
- McellB0-McellB3 all have four native product terms and may borrow up to five more
- McellB4-McellB7 all have four native product terms and may borrow up to six more.

Each Macrocell may only borrow product terms from certain other Macrocells. Product terms already in use by one Macrocell are not available for another Macrocell.

If an equation requires more product terms than are available to it, then “external” product terms are required, which consume other Output Macrocells (OMC). If external product terms are used, extra delay is added for the equation that required the extra product terms. This is called product term expansion. PSDsoft Express performs this expansion as needed.

Loading and Reading the Output Macrocells (OMC). The Output Macrocells (OMC) block occupies a memory location in the MCU address space, as defined by the CSIOP (see the section entitled “I/O Ports”, on page 50). The flip-flops in each of the 16 Output Macrocells (OMC) can be loaded from the data bus by a MCU. Loading the Output Macrocells (OMC) with data from the MCU takes priority over internal functions. As such, the preset, clear, and clock inputs to the flip-flop can be overridden by the MCU. The ability to load the flip-flops and read them back is useful in such applications as loadable counters and shift registers, mailboxes, and handshaking protocols.

Data is loaded to the Output Macrocells (OMC) on the trailing edge of Write Strobe (WR/WRL, CNTL0).

The OMC Mask Register. There is one Mask Register for each of the two groups of eight Output Macrocells (OMC). The Mask Registers can be used to block the loading of data to individual Output Macrocells (OMC). The default value for the Mask Registers is 00h, which allows loading of the Output Macrocells (OMC). When a given bit in a Mask Register is set to a 1, the MCU is blocked from writing to the associated Output Macrocells

(OMC). For example, suppose McellA0-McellA3 are being used for a state machine. You would not want a MCU write to McellA to overwrite the state machine registers. Therefore, you would want to load the Mask Register for McellA (Mask Macrocell A) with the value 0Fh.

The Output Enable of the OMC. The Output Macrocells (OMC) can be connected to an I/O port pin as a PLD output. The output enable of each port pin driver is controlled by a single product term from the AND Array, ORed with the Direction Register output. The pin is enabled upon Power-up if no output enable equation is defined and if the pin is declared as a PLD output in PSDsoft Express.

If the Output Macrocell (OMC) output is declared as an internal node and not as a port pin output in the PSDabel file, then the port pin can be used for other I/O functions. The internal node feedback can be routed as an input to the AND Array.

Input Macrocells (IMC). The CPLD has 24 Input Macrocells (IMC), one for each pin on Ports A, B, and C. The architecture of the Input Macrocells (IMC) is shown in Figure 16. The Input Macrocells (IMC) are individually configurable, and can be used as a latch, register, or to pass incoming Port signals prior to driving them onto the PLD input bus. The outputs of the Input Macrocells (IMC) can be read by the MCU through the internal data bus. The enable for the latch and clock for the register are driven by a multiplexer whose inputs are a

product term from the CPLD AND Array or the MCU Address Strobe (ALE/AS). Each product term output is used to latch or clock four Input Macrocells (IMC). Port inputs 3-0 can be controlled by one product term and 7-4 by another.

Configurations for the Input Macrocells (IMC) are specified by PSDsoft Express (see Application Note AN1171). Outputs of the Input Macrocells (IMC) can be read by the MCU via the IMC buffer. See the section entitled "I/O Ports", on page 50.

Input Macrocells (IMC) can use Address Strobe (ALE/AS, PD0) to latch address bits higher than A15. Any latched addresses are routed to the PLDs as inputs.

Input Macrocells (IMC) are particularly useful with handshaking communication applications where two processors pass data back and forth through a common mailbox. Figure 18 shows a typical configuration where the Master MCU writes to the Port A Data Out Register. This, in turn, can be read by the Slave MCU via the activation of the "Slave-Read" output enable product term.

The Slave can also write to the Port A Input Macrocells (IMC) and the Master can then read the Input Macrocells (IMC) directly.

Note that the "Slave-Read" and "Slave-Wr" signals are product terms that are derived from the Slave MCU inputs Read Strobe (RD, CNTL1), Write Strobe (WR/WRL, CNTL0), and Slave_CS.

Figure 16. Input Macrocell

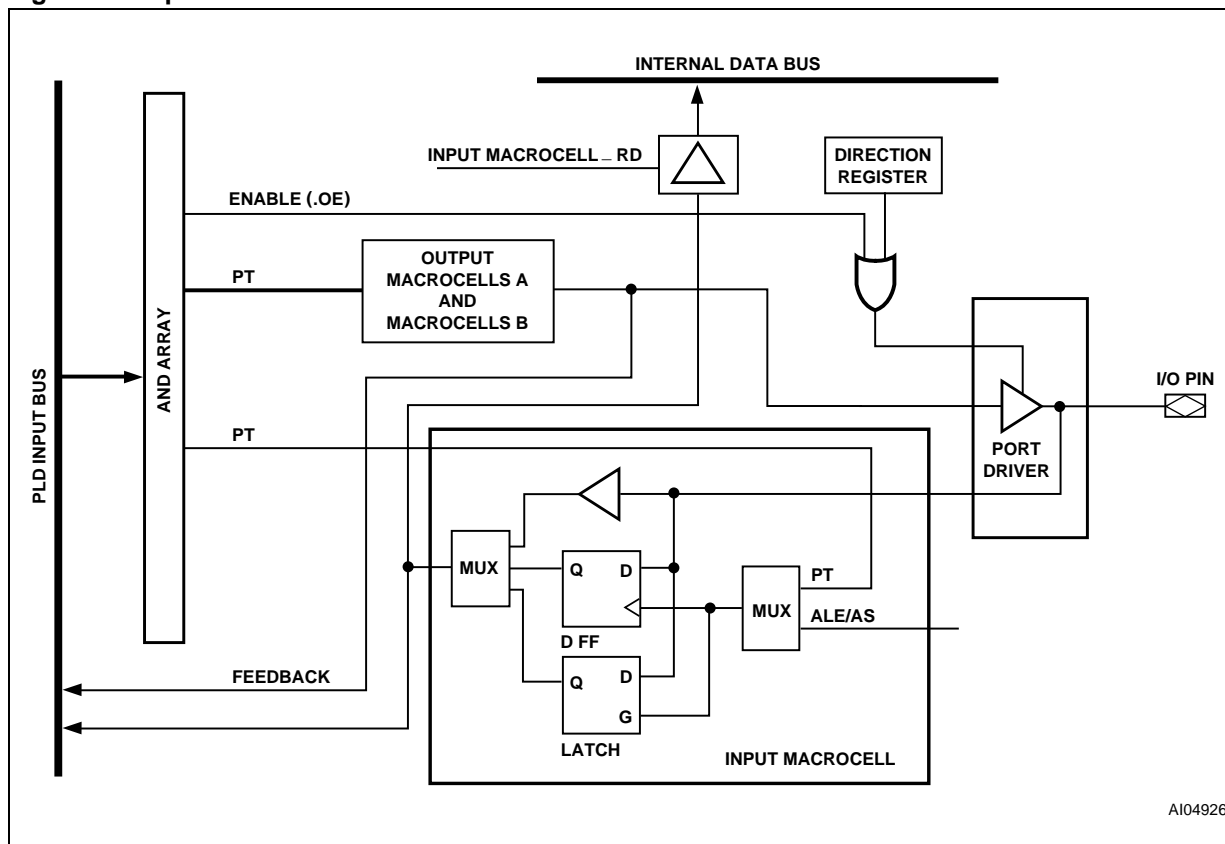

AI04926

External Chip Select. The CPLD also provides eight External Chip Select (ECS0-ECS7) outputs that can be used to select external devices. Each External Chip Select (ECS0-ECS7) consists of

one product term that can be configured active High or Low.

The output enable of the pin is controlled by either the output enable product term or the Direction Register. (See Figure 17.)

Figure 17. External Chip Select Signal

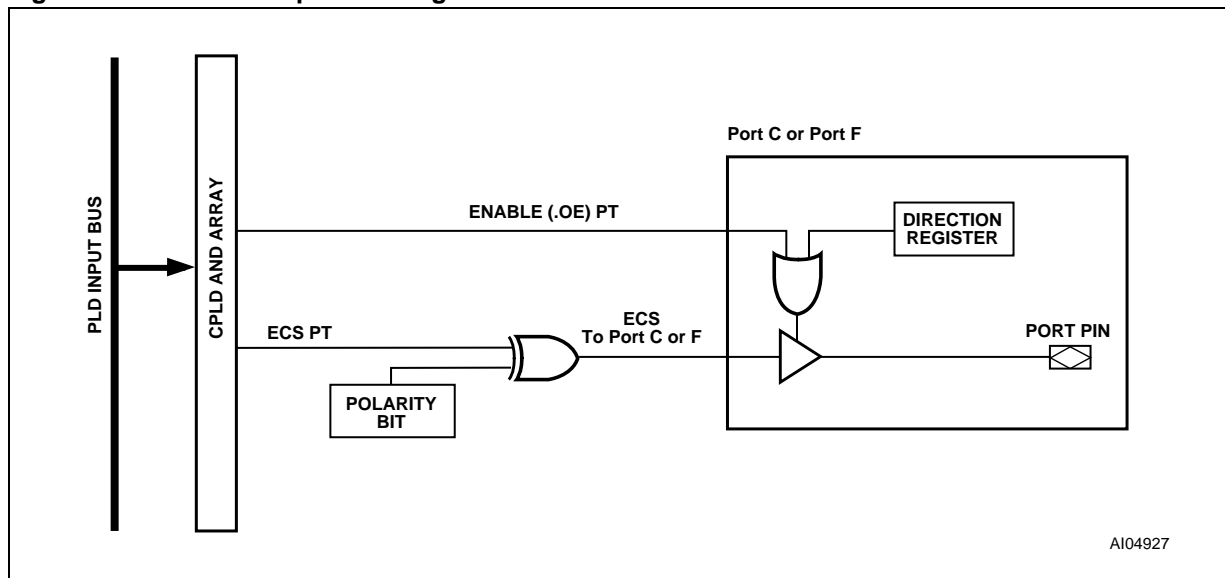

AI04927

Figure 18. Handshaking Communication Using Input Macrocells

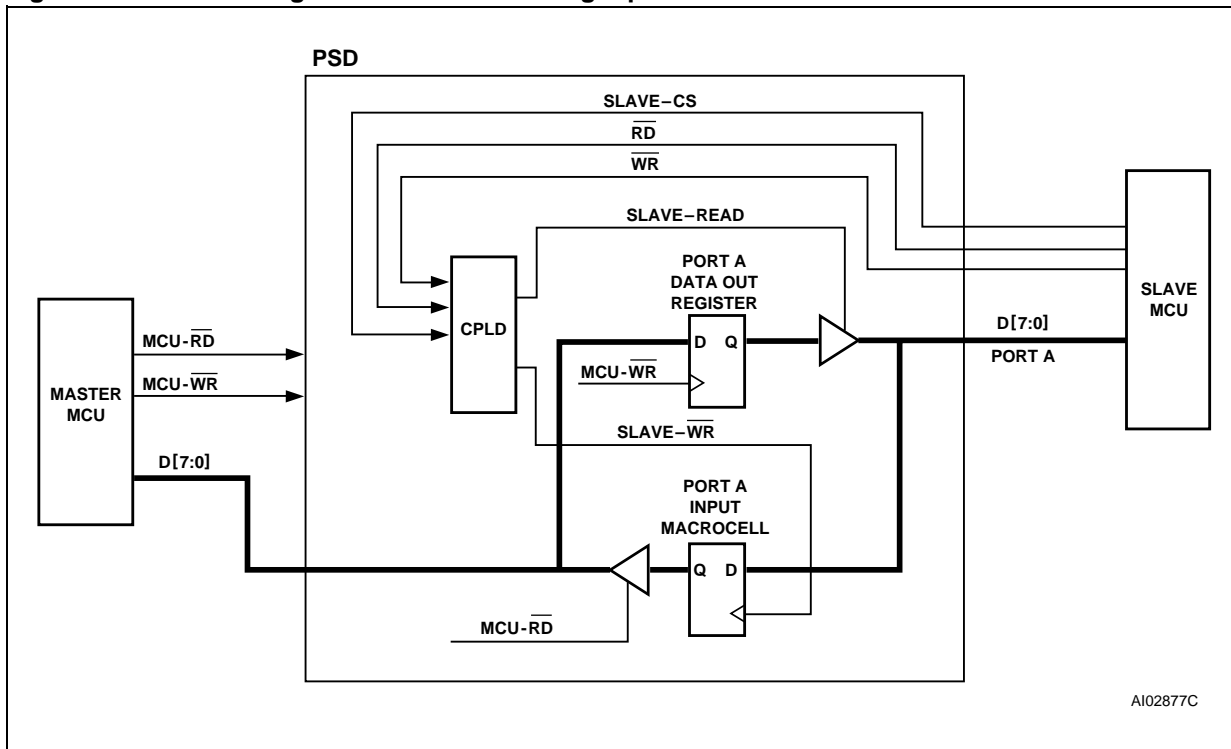

AI02877C

MCU BUS INTERFACE

The “no-glue logic” MCU Bus Interface block can be directly connected to most popular MCUs and their control signals. Key 16-bit MCUs, with their bus types and control signals, are shown in Table 34. The MCU interface type is specified using the PSDsoft Express.

PSD Interface to a Multiplexed Bus. Figure 19 shows an example of a system using a MCU with a 16-bit multiplexed bus and a PSD4235G2. The ADIO port on the PSD is connected directly to the MCU address/data bus. Address Strobe (ALE/AS, PD0) latches the address signals internally. Latched addresses can be brought out to Port E, F or G. The PSD drives the ADIO data bus only when one of its internal resources is accessed and

Read Strobe (\overline{RD} , CNTL1) is active. Should the system address bus exceed sixteen bits, Ports A, B, C, or F may be used as additional address inputs.

PSD Interface to a Non-Multiplexed 8-Bit Bus.

Figure 20 shows an example of a system using a MCU with a 16-bit non-multiplexed bus and a PSD4235G2. The address bus is connected to the ADIO Port, and the data bus is connected to Ports F and G. Ports F and G are in tri-state mode when the PSD is not accessed by the MCU. Should the system address bus exceed sixteen bits, Ports A, B, or C may be used for additional address inputs.

Table 34. MCUs and their Control Signals

MCU	CNTL0	CNTL1	CNTL2	PD3	PD0 ²	ADIO0	PF3-PF0
68302, 68306, MMC2001	$R\overline{W}$	\overline{LDS}	\overline{UDS}	(Note 1)	AS	—	(Note 1)
68330, 68331, 68332, 68340	$R\overline{W}$	\overline{DS}	SIZ0	(Note 1)	AS	A0	(Note 1)
68LC302, MMC2001	\overline{WEL}	\overline{OE}	—	\overline{WEH}	AS	—	(Note 1)
68HC16	$R\overline{W}$	\overline{DS}	SIZ0	(Note 1)	AS	A0	(Note 1)
68HC912	$R\overline{W}$	E	\overline{LSTRB}	\overline{DBE}	E	A0	(Note 1)
68HC812 ³	$R\overline{W}$	E	\overline{LSTRB}	(Note 1)	(Note 1)	A0	(Note 1)
80196	\overline{WR}	\overline{RD}	\overline{BHE}	(Note 1)	ALE	A0	(Note 1)
80196SP	\overline{WRL}	\overline{RD}	(Note 1)	\overline{WRH}	ALE	A0	(Note 1)
80186	\overline{WR}	\overline{RD}	\overline{BHE}	(Note 1)	ALE	A0	(Note 1)
80C161, 80C164-80C167	\overline{WR}	\overline{RD}	\overline{BHE}	(Note 1)	ALE	A0	(Note 1)
80C51XA	\overline{WRL}	\overline{RD}	\overline{PSEN}	\overline{WRH}	ALE	A4/D0	A3-A1
H8/300	\overline{WRL}	\overline{RD}	(Note 1)	\overline{WRH}	AS	A0	—
M37702M2	$R\overline{W}$	\overline{E}	\overline{BHE}	(Note 1)	ALE	A0	(Note 1)

Note: 1. Unused CNTL2 pin can be configured as CPLD input. Other unused pins (PD3-PD0, PF3-PF0) can be configured for other I/O functions.

2. ALE/AS input is optional for MCUs with a non-multiplexed bus

Figure 19. An Example of a Typical 16-bit Multiplexed Bus Interface

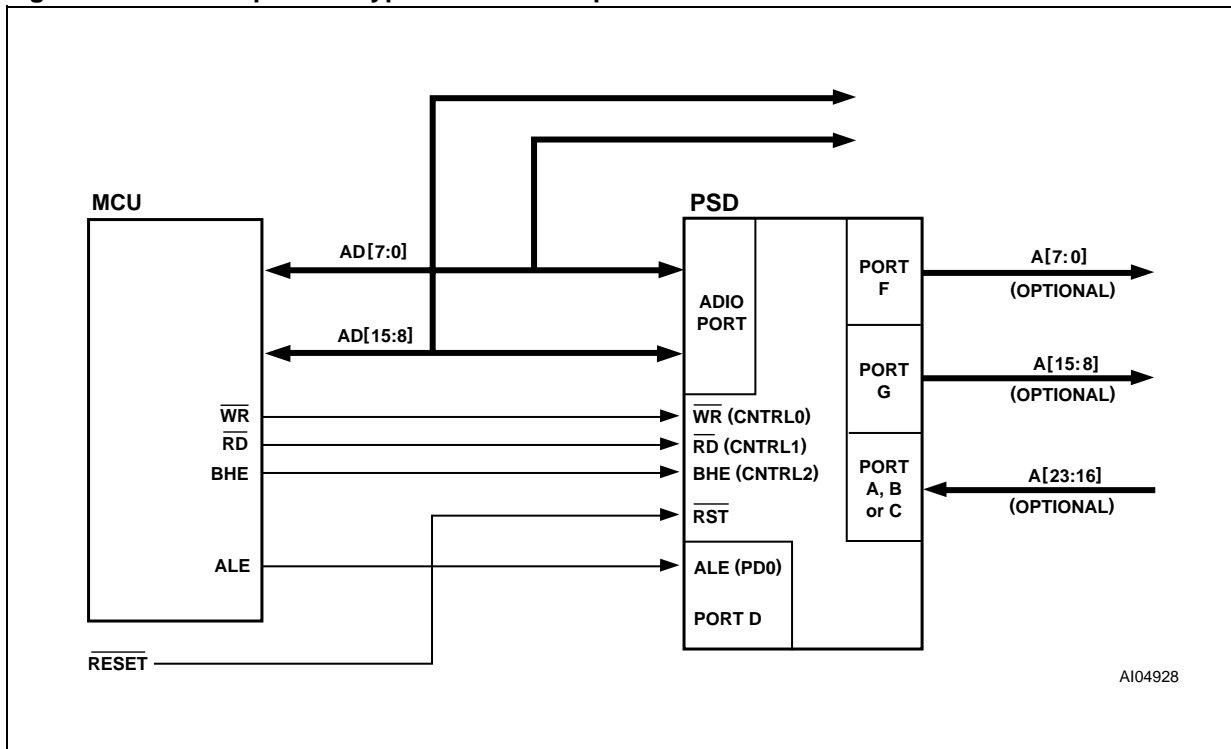
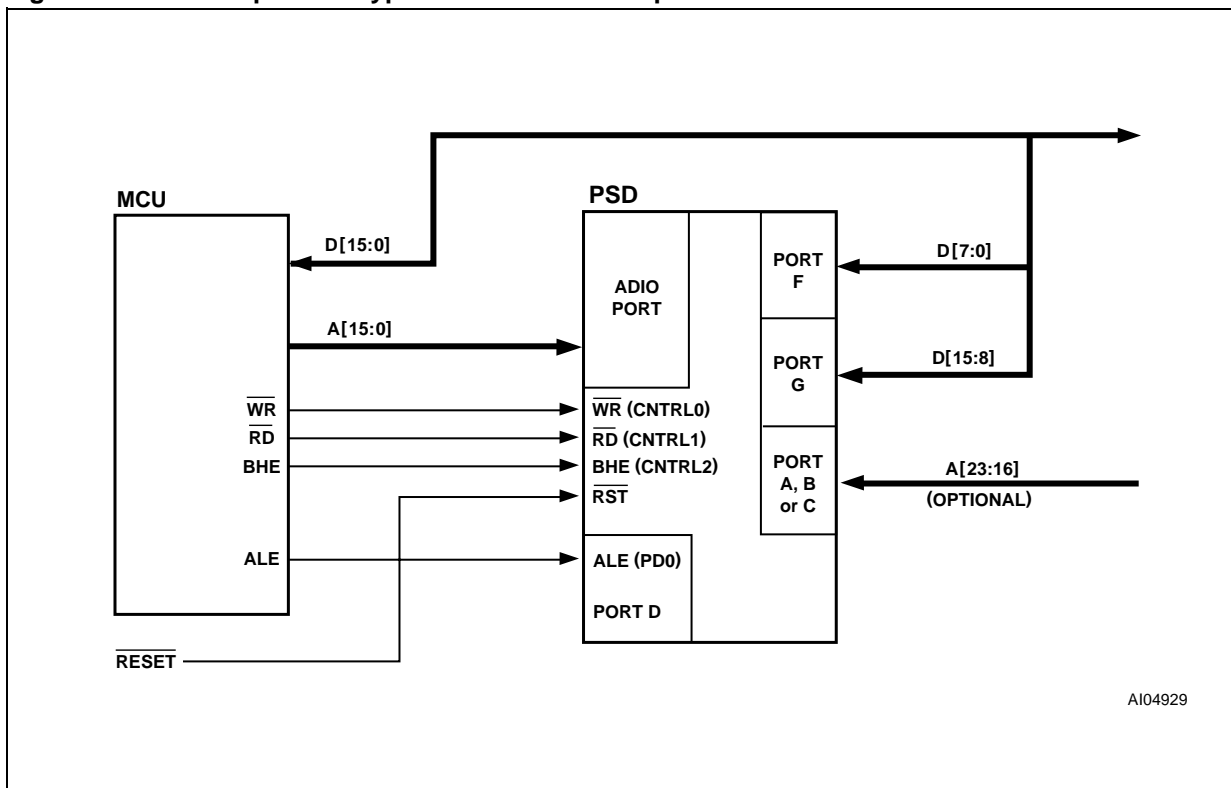

Figure 20. An Example of a Typical 16-bit Non-Multiplexed Bus Interface



Data Byte Enable Reference. MCUs have different data byte orientations. Table 35 to Table 38 show how the PSD4235G2 interprets byte/word operations in different bus write configurations. Even-byte refers to locations with address A0 equal to 0, and odd byte as locations with A0 equal to 1.

Table 35. 16-Bit Data Bus with BHE

BHE	A0	D15-D8	D7-D0
0	0	Odd Byte	Even Byte
0	1	Odd Byte	—
1	0	—	Even Byte

MCU Bus Interface Examples. Figure 21 to Figure 26 show examples of the basic connections between the PSD4235G2 and some popular MCUs. The PSD4235G2 Control input pins are labeled as to the MCU function for which they are configured. The MCU bus interface is specified using PSDsoft Express. The Voltage Stand-by (VST-BY, PE6) line should be held at Ground if not in use.

Table 36. 16-Bit Data Bus with WRH and WRL

WRH	WRL	D15-D8	D7-D0
0	0	Odd Byte	Even Byte
0	1	Odd Byte	—
1	0	—	Even Byte

Table 37. 16-Bit Data Bus with SIZ0, A0 (Motorola MCU)

SIZ0	A0	D15-D8	D7-D0
0	0	Even Byte	Odd Byte
1	0	Even Byte	—
1	1	—	Odd Byte

Table 38. 16-Bit Data Bus with LDS, UDS (Motorola MCU)

WRH	WRL	D15-D8	D7-D0
0	0	Even Byte	Odd Byte
1	0	Even Byte	—
0	1	—	Odd Byte

Figure 21. Interfacing the PSD with an 80C196

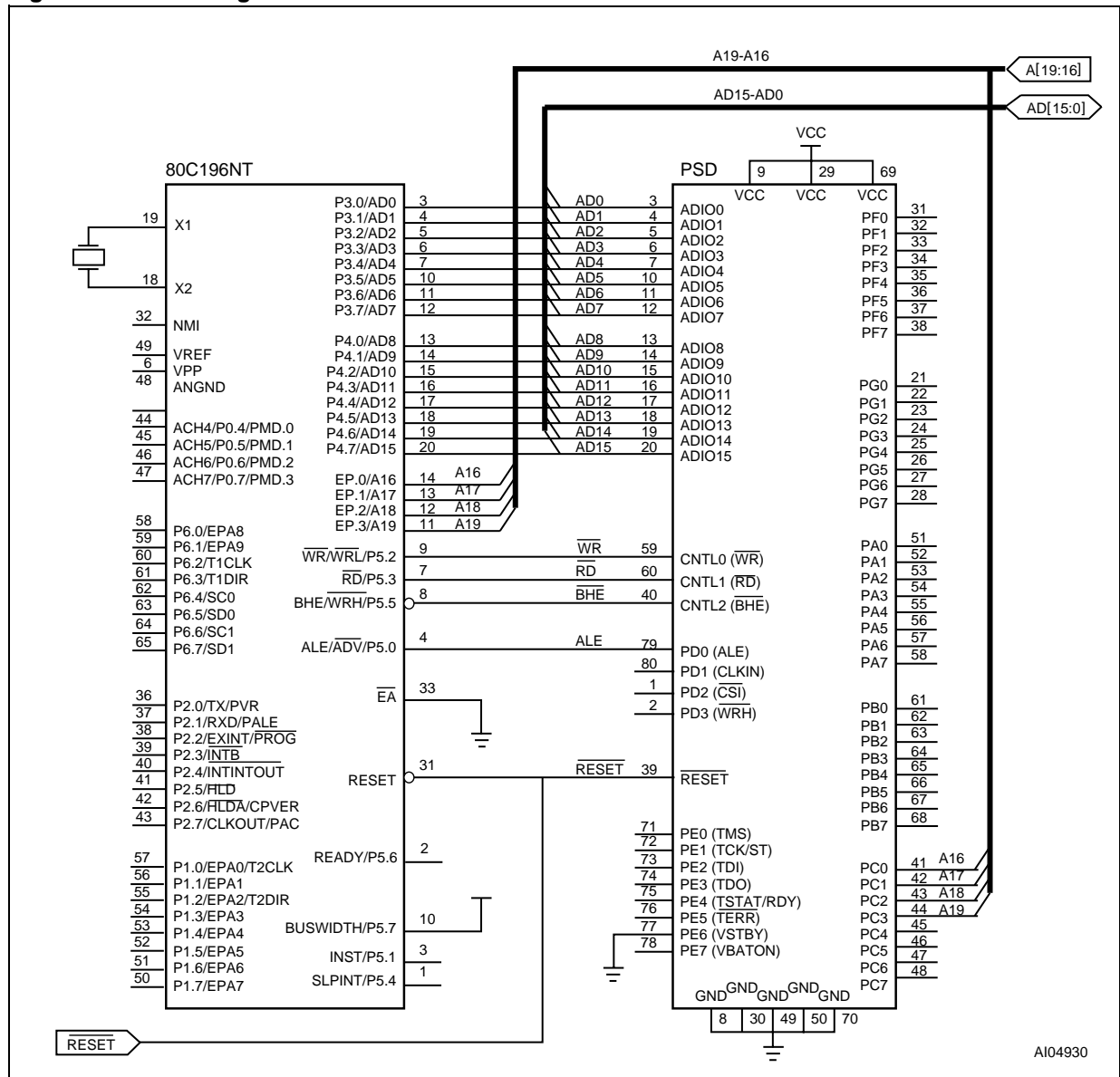

80C196 and 80C186. In Figure 21, the Intel 80C196 MCU, which has a 16-bit multiplexed address/data bus, is shown connected to a PSD4235G2. The Read Strobe (\overline{RD} , CNTL1), and Write Strobe ($\overline{WR}/\overline{WRL}$, CNTL0) signals are connected to the CNTL pins. When BHE is not used, the PSD can be configured to receive WRL and

Write Enable High-byte ($\overline{WRH}/\overline{DBE}$, PD3) from the MCU. Higher address inputs (A16-A19) can be routed to Ports A, B, or C as input of the PLD. The AMD 80186 family has the same bus connection to the PSD as the 80C196.



Figure 22. Interfacing the PSD with an MC68331

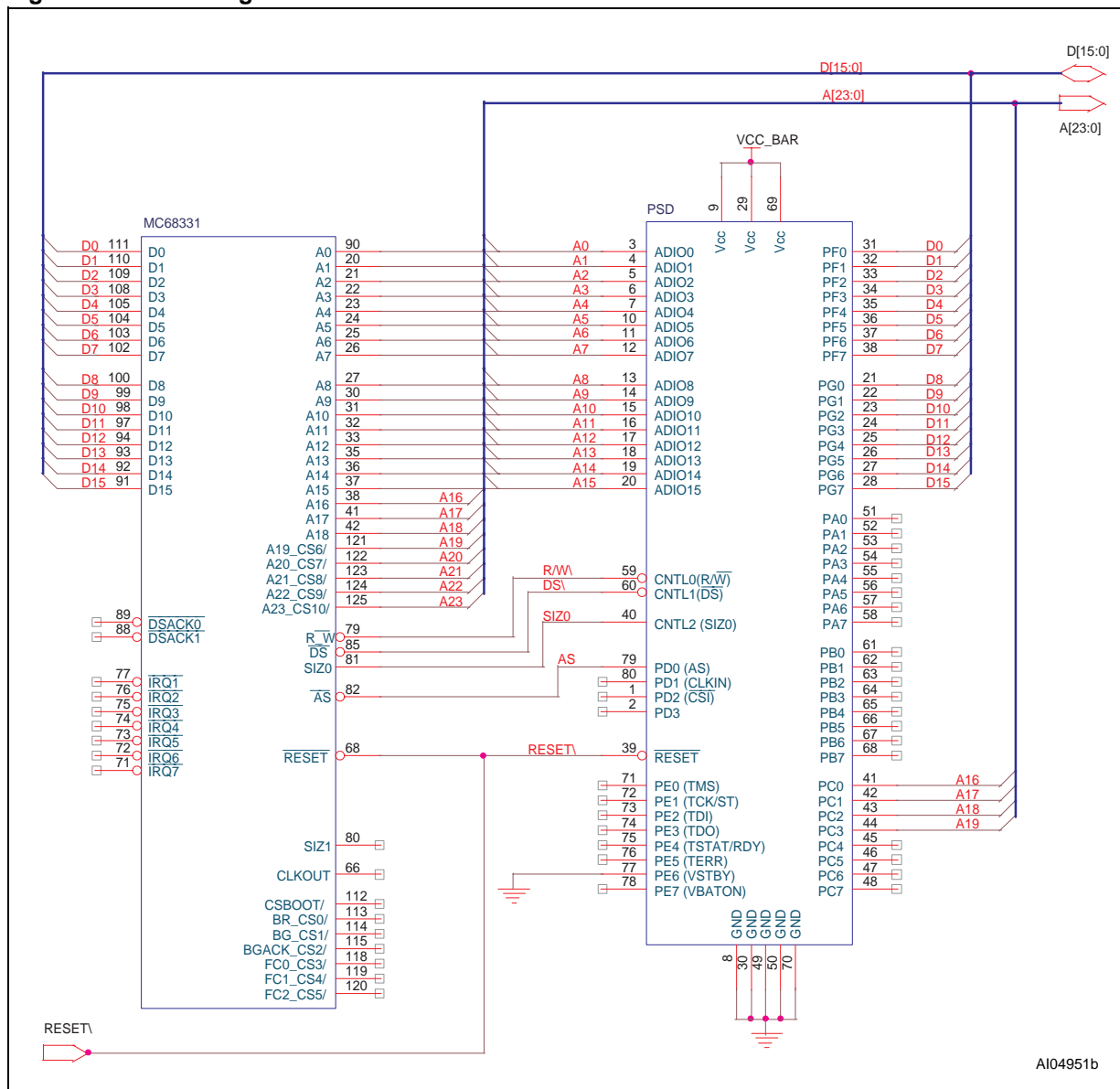

MC683xx and MC68HC16. Figure 22 shows a MC68331 with a 16-bit non-multiplexed data bus and 24-bit address bus. The data bus from the MC68331 is connected to Port F (D0-D7) and Port G (D8-D15). The SIZ0 and A0 inputs determine

the high/low byte selection. The R/W, DS and SIZ0 signals are connected to the CNTL0-CNTL2 pins. The MC68HC16, and other members of the MC683xx family, has the same bus connection to the PSD as the MC68331 shown in Figure 22.

Figure 23. Interfacing the PSD with an 80C51XA-G3

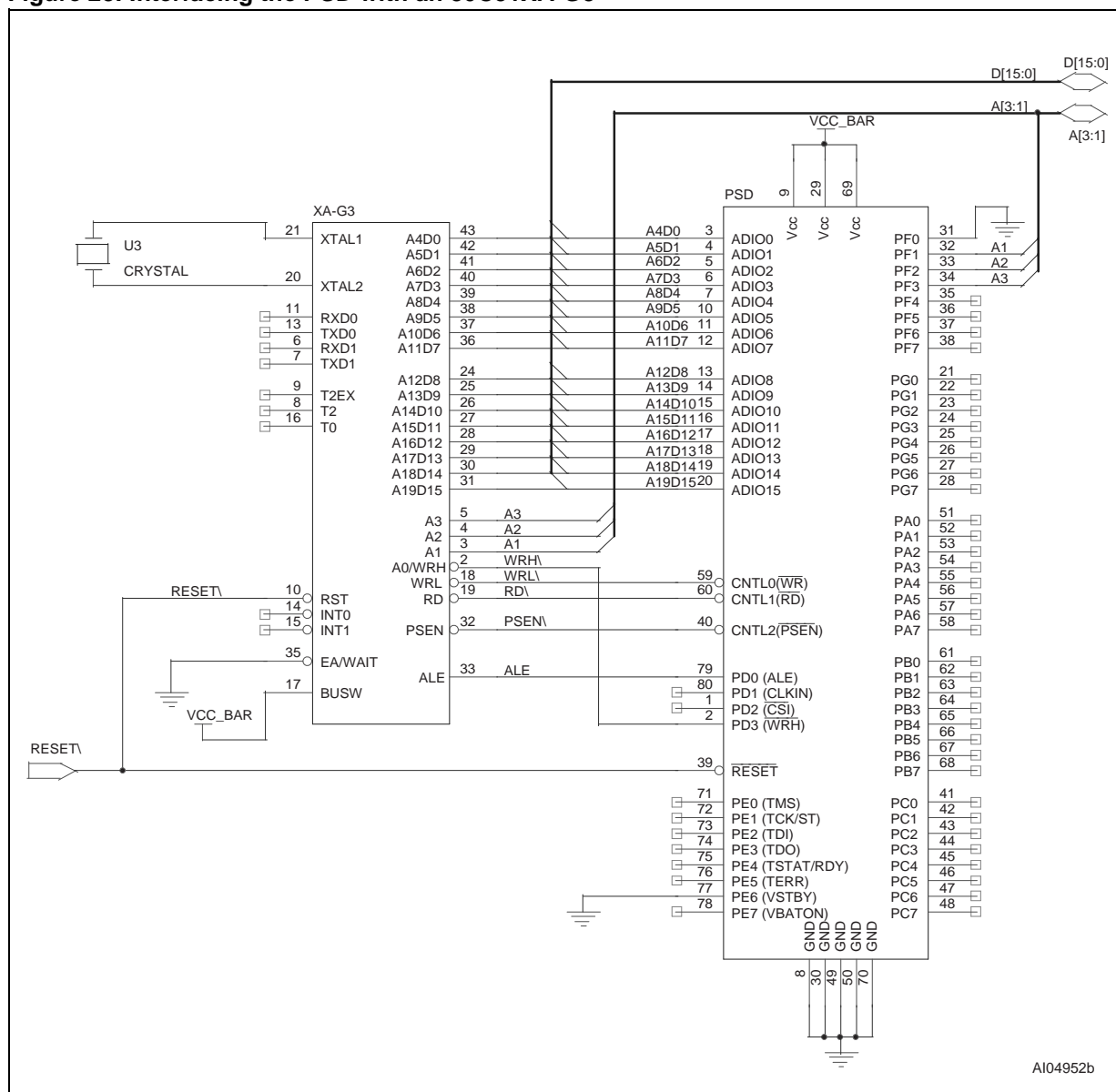

80C51XA. The Philips 80C51XA MCU has a 16-bit multiplexed bus with burst cycles. Address bits (A3-A1) are not multiplexed, while (A19-A4) are multiplexed with data bits (D15-D0).

The PSD4235G2 supports the 80C51XA burst mode. The \overline{WRH} signal is connected to PD3, and \overline{WRL} is connected to CNTL0. The \overline{RD} and \overline{PSEN} signals are connected to the CNTL1 and CNTL2 pins. Figure 23 shows the schematic diagram.

The 80C51XA improves bus throughput and performance by issuing burst cycles to fetch codes from memory. In burst cycles, address A19-A4 are latched internally by the PSD, while the 80C51XA drives the A3-A1 signals to fetch sequentially up to 16 bytes of code. The PSD access time is then measured from address A3-A1 valid to data in valid. The PSD bus timing requirement in a burst cycle is identical to the normal bus cycle, except the address setup and hold time with respect to Address Strobe (ALE/AS, PD0) is not required.

Figure 24. Interfacing the PSD with an H83/2350

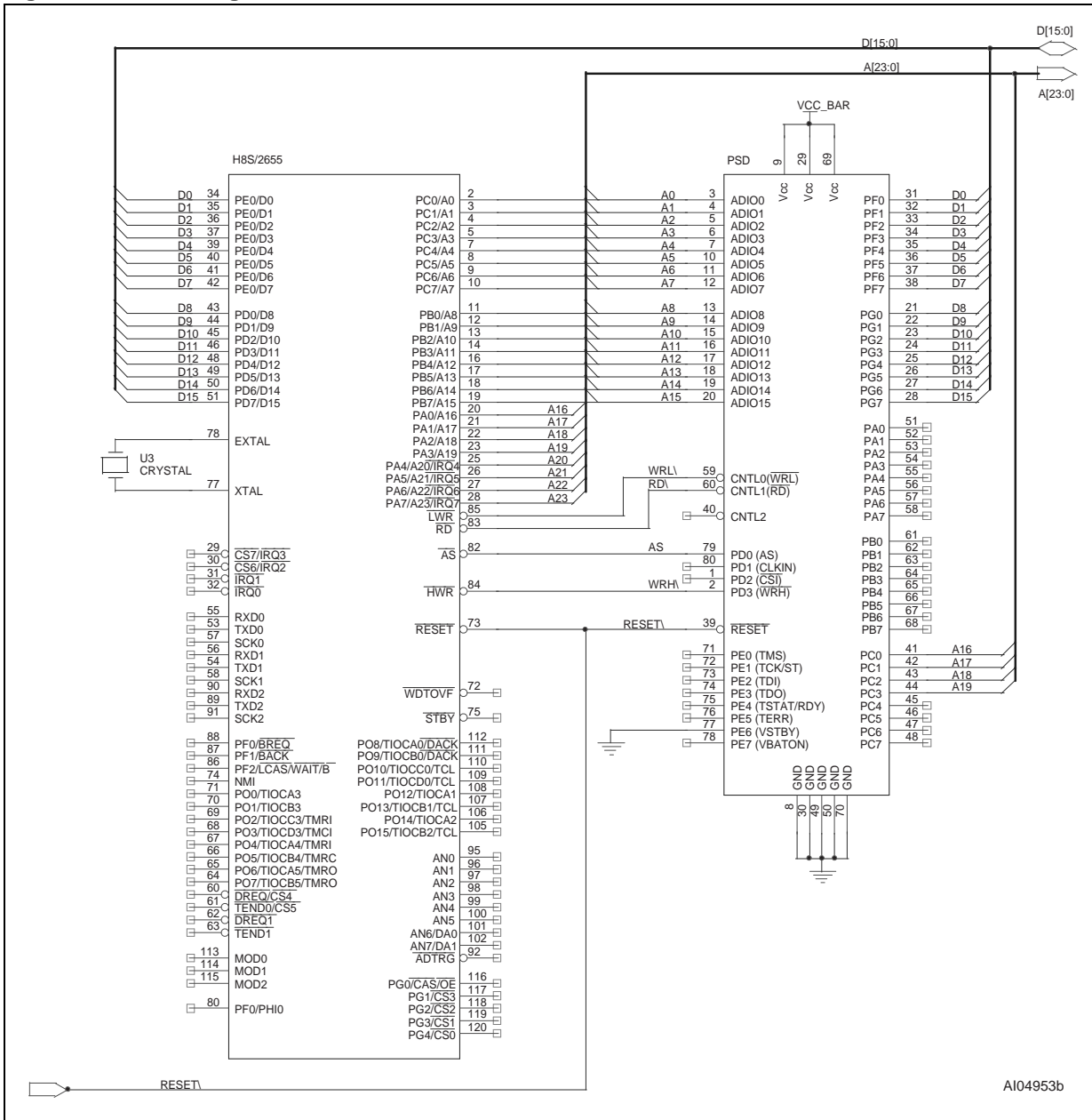

H8/300. Figure 24 shows an Hitachi H8/2350 with a 16-bit non-multiplexed data bus, and a 24-bit address bus. The H8 data bus is connected to Port F (D0-D7) and Port G (D8-D15).

The \overline{WRH} signal is connected to PD3, and \overline{WHL} is connected to CNTL0. The \overline{RD} signal is connected to CNTL1. The connection to the Address Strobe (AS) signal is optional, and is required if the addresses are to be latched.

Figure 25. Interfacing the PSD with an MMC2001

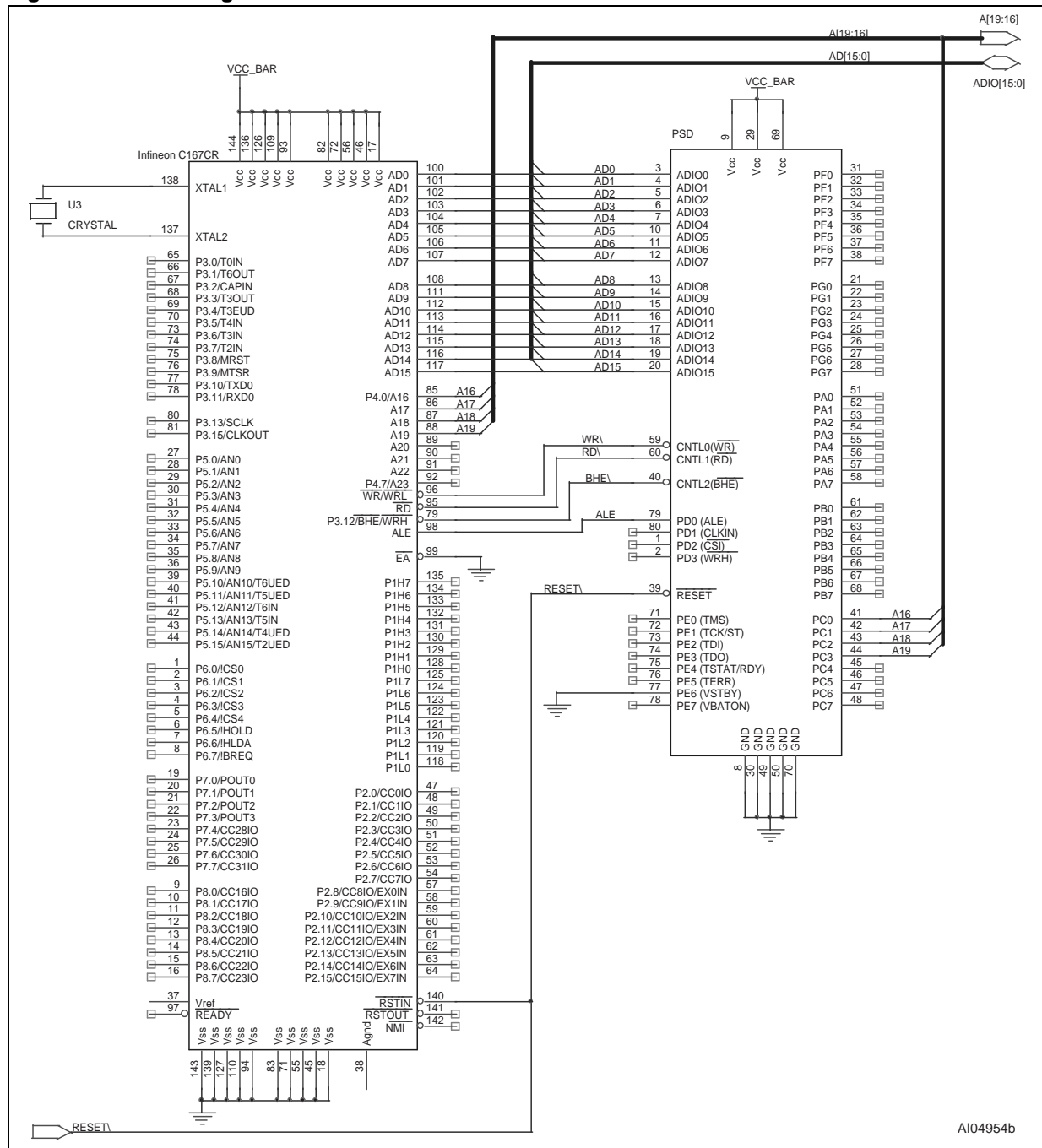

MMC2001. The Motorola MCODE MMC2001 MCU has a MOD input pin that selects internal or external boot ROM. The PSD can be configured as the external flash boot ROM or as extension to the internal ROM.

The MMC2001 has a 16-bit external data bus and 20 address lines with external chip select signals. The Chip Select Control Registers allow the user to customize the bus interface and timing to fit the individual system requirement. A typical interface

configuration to the PSD is shown in Figure 25. The MMC2001's R/W signal is connected to the CNTL0 pin, while EB0 and EB1 (enable byte-0 and enable byte-1) are connected to the CNTL1 (UDS) and CNTL2 (LDS) pins. The WEN bit in the Chip Select Control Register should be set to 1 to terminate the EB0-EB1 earlier to provide the write data hold time for the PSD. The WSC and WWS bits in the Control Register are set to wait states that meet the PSD access time requirement.



PSD4235G2

Another option is to configure the $\overline{EB0}$ and $\overline{EB1}$ as \overline{WRL} and \overline{WRH} signals. In this case, the PSD control setting will be: \overline{OE} , \overline{WRL} , \overline{WRH} where \overline{OE} is the read signal for the MMC2001.

C16x Family. The PSD supports Infineon's C16X family of MCUs (C161-C167) in both the multiplexed and non-multiplexed bus configuration. In Figure 26, the C167CR is shown connected to the

PSD in a multiplexed bus configuration. The control signals from the MCU are \overline{WR} , \overline{RD} , \overline{BHE} and \overline{ALE} , and are routed to the corresponding PSD pins.

The C167 has another control signal setting (\overline{RD} , \overline{WRL} , \overline{WRH} , \overline{ALE}) which is also supported by the PSD.

Figure 26. Interfacing the PSD with a C167CR

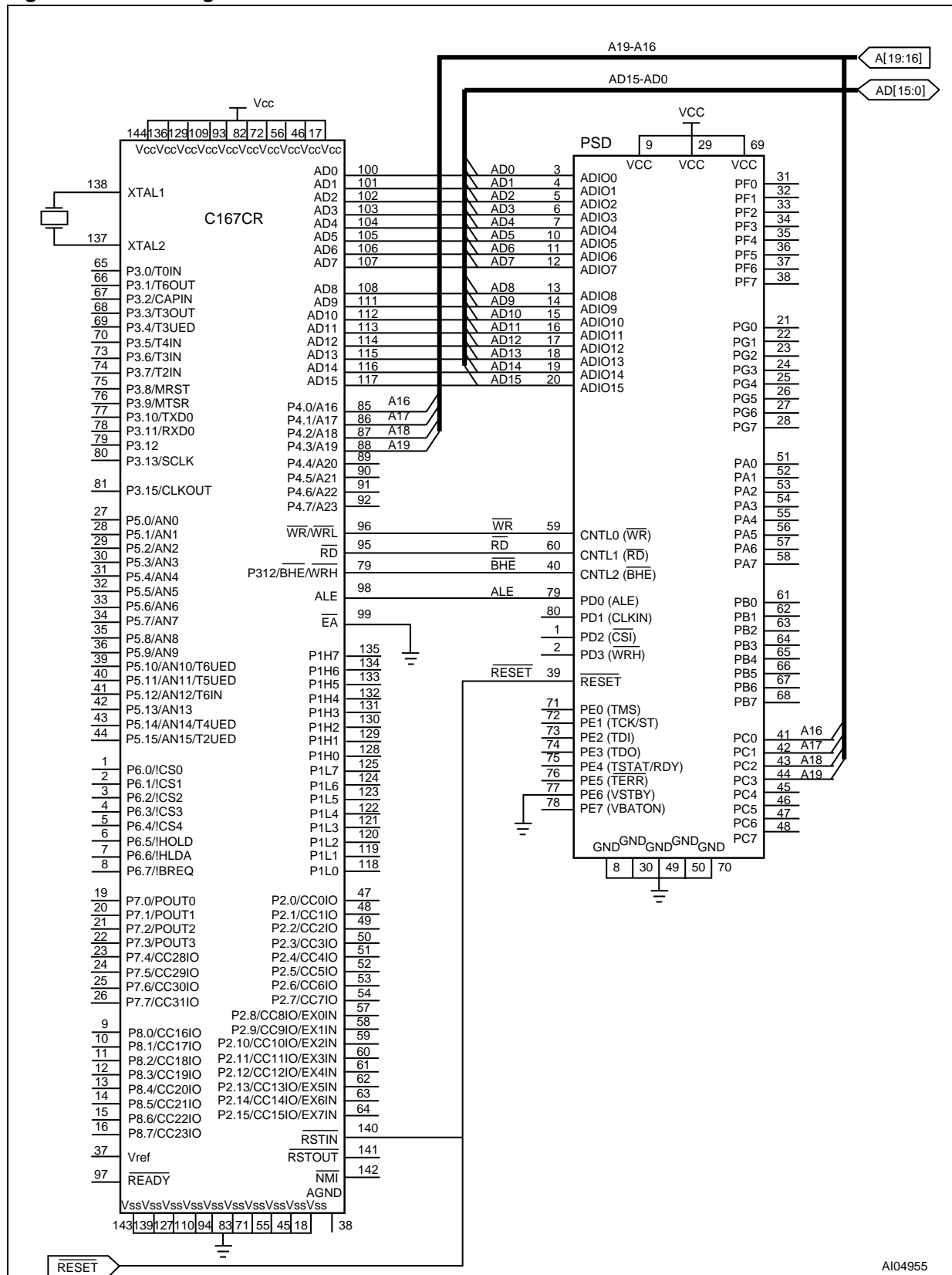

AI04955



I/O PORTS

There are seven programmable I/O ports: Ports A, B, C, D, E, F and G. Each port pin is individually user configurable, thus allowing multiple functions per port. The ports are configured using PSDsoft Express or by the MCU writing to on-chip registers in the CSIOP space.

The topics discussed in this section are:

- General Port architecture
- Port operating modes
- Port Configuration Registers (PCR)
- Port Data Registers
- Individual Port functionality.

General Port Architecture. The general architecture of the I/O Port block is shown in Figure 27. Individual Port architectures are shown in Figure 29 to Figure 31. In general, once the purpose for a port pin has been defined, that pin is no longer

available for other purposes. Exceptions are noted.

As shown in Figure 27, the ports contain an output multiplexer whose select signals are driven by the configuration bits in the Control Registers (Ports E, F and G only) and PSDsoft Express Configuration. Inputs to the multiplexer include the following:

- Output data from the Data Out register
- Latched address outputs
- CPLD Macrocell output
- External Chip Select from the CPLD.

The Port Data Buffer (PDB) is a tri-state buffer that allows only one source at a time to be read. The Port Data Buffer (PDB) is connected to the Internal Data Bus for feedback and can be read by the MCU. The Data Out and Macrocell outputs, Direction Register and Control Register, and port pin input are all connected to the Port Data Buffer (PDB).

Figure 27. General I/O Port Architecture

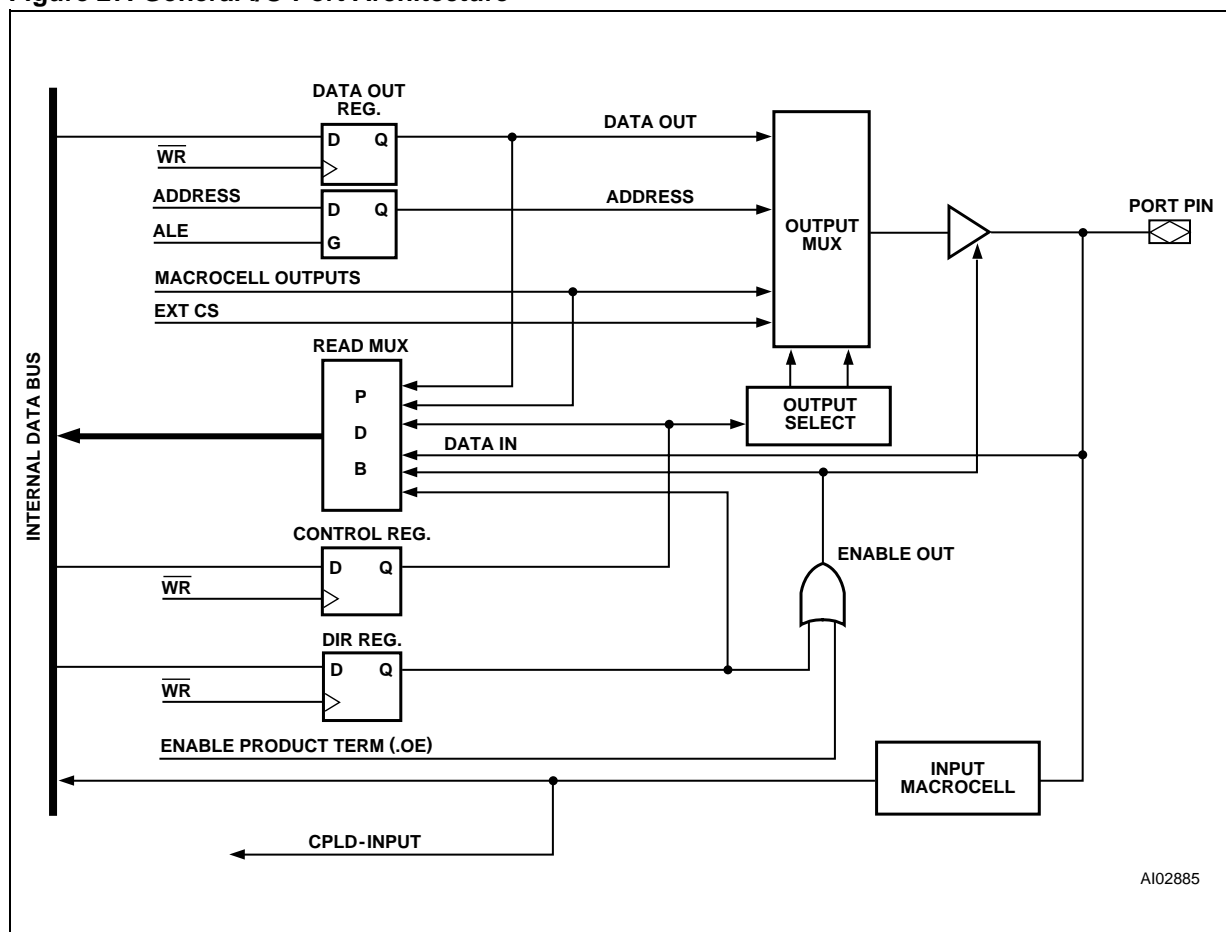

AI02885

The Port pin's tri-state output driver enable is controlled by a two input OR gate whose inputs come from the CPLD AND Array enable product term and the Direction Register. If the enable product term of any of the Array outputs are not defined and that port pin is not defined as a CPLD output in the PSDlabel file, the Direction Register has sole control of the buffer that drives the port pin.

The contents of these registers can be altered by the MCU. The Port Data Buffer (PDB) feedback path allows the MCU to check the contents of the registers.

Ports A, B, and C have embedded Input Macrocells (IMC). The Input Macrocells (IMC) can be configured as latches, registers, or direct inputs to the PLDs. The latches and registers are clocked by Address Strobe (ALE/AS, PD0) or a product term from the PLD AND Array. The outputs from the Input Macrocells (IMC) drive the PLD input bus and can be read by the MCU. See the section entitled "Input Macrocell", on page 38.

Port Operating Modes

The I/O Ports have several modes of operation. Some modes can be defined using PSDsoft Express, some by the MCU writing to the registers in CSIOP space, and some by both. The modes that can only be defined using PSDsoft Express must be programmed into the device and cannot be changed unless the device is reprogrammed. The modes that can be changed by the MCU can be done so dynamically at run-time. The PLD I/O, Data Port, Address Input, Peripheral I/O and MCU Reset modes are the only modes that must be defined before programming the device. All other modes can be changed by the MCU at run-time. See Application Note *AN1171* for more detail.

Table 39 summarizes which modes are available on each port. Table 40 shows how and where the different modes are configured. Each of the port operating modes are described in the following sections.

MCU I/O Mode. In the MCU I/O mode, the MCU uses the PSD Ports to expand its own I/O ports. By setting up the CSIOP space, the ports on the PSD are mapped into the MCU address space. The addresses of the ports are listed in Table 6.

A port pin can be put into MCU I/O mode by writing a 0 to the corresponding bit in the Control Register (for Ports E, F and G). The MCU I/O direction may be changed by writing to the corresponding bit in the Direction Register, or by the output enable product term. See the section entitled "Port Operating Modes", on page 51. When the pin is configured as an output, the content of the Data Out Register drives the pin. When configured as an input, the MCU can read the port input through the Data In buffer. See Figure 27.

Ports A, B and C do not have Control Registers, and are in MCU I/O mode by default. They can be used for PLD I/O if they are specified in PSDsoft Express.

PLD I/O Mode. The PLD I/O Mode uses a port as an input to the CPLD's Input Macrocells (IMC), and/or as an output from the CPLD's Output Macrocells (OMC). The output can be tri-stated with a control signal. This output enable control signal can be defined by a product term from the PLD, or by resetting the corresponding bit in the Direction Register to 0. The corresponding bit in the Direction Register must not be set to 1 if the pin is defined for a PLD input signal in PSDsoft Express. The PLD I/O mode is specified in PSDsoft Express by declaring the port pins, and then specifying an equation in PSDsoft Express.

Address Out Mode. For MCUs with a multiplexed address/data bus, Address Out mode can be used to drive latched addresses onto the port pins. These port pins can, in turn, drive external devices. Either the output enable or the corresponding bits of both the Direction Register and Control Register must be set to a 1 for pins to use Address Out mode. This must be done by the MCU at run-time. See Table 41 for the address output pin assignments on Ports E, F and G for various MCUs.

Note: Do not drive address signals with Address Out Mode to an external memory device if it is intended for the MCU to Boot from the external device. The MCU must first Boot from PSD memory so the Direction and Control register bits can be set.

Table 39. Port Operating Modes

Port Mode	Port A	Port B	Port C	Port D	Port E	Port F	Port G
MCU I/O	Yes	Yes	Yes	Yes	Yes	Yes	Yes
PLD I/O							
McellA Outputs	Yes	Yes	No	No	No	No	No
McellB Outputs	No	Yes	No	No	No	No	No
Additional Ext. CS Outputs	No	No	Yes	No	No	Yes	No
PLD Inputs	Yes	Yes	Yes	Yes	No	Yes	No
Address Out	No	No	No	No	Yes (A7 – 0)	Yes (A7 – 0)	Yes (A7 – 0) or (A15 – 8)
Address In	Yes	Yes	Yes	Yes	No	Yes	No
Data Port	No	No	No	No	No	Yes	Yes
Peripheral I/O	Yes	No	No	Yes	No	Yes	No
JTAG ISP	No	No	No	No	Yes ¹	No	No
MCU Reset Mode ²	No	No	No	No	No	Yes	Yes

Note: 1. Can be multiplexed with other I/O functions.
 2. Available to Motorola 16-bit 683xx and HC16 families of MCUs.

Table 40. Port Operating Mode Settings

Mode	Defined in PSDsoft Express	Control Register Setting	Direction Register Setting	VM Register Setting	JTAG Enable
MCU I/O	Declare pins only	0 (Note ⁴)	1 = output, 0 = input (Note ²)	N/A	N/A
PLD I/O	Declare pins and Logic equations	N/A	(Note ²)	N/A	N/A
Data Port (Port F, G)	Selected for MCU with non-multiplexed bus	N/A	N/A	N/A	N/A
Address Out (Port E, F, G)	Declare pins only	1	1 (Note ²)	N/A	N/A
Address In (Port A, B, C, D, F)	Declare pins or Logic equation for Input Macrocells	N/A	N/A	N/A	N/A
Peripheral I/O (Port F)	Logic equations (PSEL0 and PSEL1)	N/A	N/A	PIO bit = 1	N/A
JTAG ISP ³	Declare pins only	N/A	N/A	N/A	JTAG_Enable
MCU Reset Mode	Specific pin logic level	N/A	N/A	N/A	N/A

Note: 1. N/A = Not Applicable
 2. The direction of the Port A,B,C, and F pins are controlled by the Direction Register ORed with the individual output enable product term (.oe) from the CPLD AND Array.
 3. Any of these three methods enables the JTAG pins on Port E.
 4. Control Register setting is not applicable to Ports A, B and C.



Table 41. I/O Port Latched Address Output Assignments

MCU	Port E (PE3-PE0)	Port E (PE7-PE4)	Port F (PF3-PF0)	Port F (PF7-PF4)	Port G (PG3-PG0)	Port G (PG7-PG4)
80C51XA	N/A ¹	Address a7-a4	N/A	Address a7-a4	Address a11-a8	Address a15-a12
All Other MCU with Multiplexed Bus	Address a3-a0	Address a7-a4	Address a3-a0	Address a7-a4	Address a11-a8	Address a15-a12

Note: 1. N/A = Not Applicable.

Address In Mode. For MCUs that have more than 16 address signals, the higher addresses can be connected to Port A, B, C, D or F, and are routed as inputs to the PLDs. The address input can be latched in the Input Macrocell (IMC) by Address Strobe (ALE/AS, PDO). Any input that is included in the DPLD equations for the primary Flash memory, secondary Flash memory or SRAM is considered to be an address input.

Data Port Mode. Ports F and G can be used as a data bus port for a MCU with a non-multiplexed address/data bus. The Data Port is connected to the data bus of the MCU. The general I/O functions are disabled in Ports F and G if the ports are configured as a Data Port. Data Port mode is automatically configured in PSDsoft Express when a non-multiplexed bus MCU is selected.

Peripheral I/O Mode. Peripheral I/O mode can be used to interface with external 8-bit peripherals. In this mode, all of Port F serves as a tri-state, bi-directional data buffer for the MCU. Peripheral I/O mode is enabled by setting bit 7 of the VM Register to a 1. Figure 28 shows how Port A acts as a bi-directional buffer for the MCU data bus if Peripheral I/O mode is enabled. An equation for PSEL0 and/or PSEL1 must be specified in PSDsoft Express. The buffer is tri-stated when PSEL0 or PSEL1 is not active.

JTAG In-System Programming (ISP). Port E is JTAG compliant, and can be used for In-System Programming (ISP). You can multiplex JTAG operations with other functions on Port E because In-System Programming (ISP) is not performed during normal system operation. For more information on the JTAG Port, see the section entitled "Reset (RESET) Timing", on page 63.

MCU Reset Mode. Ports F and G can be configured to operate in MCU Reset mode. This mode is available when PSD is configured for the Motorola 16-bit 683xx and HC16 family and is active only during reset.

At the rising edge of the Reset input, the MCU reads the logic level on the data bus (D15-D0) pins. The MCU then configures some of its I/O pin functions according to the logic level input on the

data bus lines. Two dedicated buffers are usually enabled during reset to drive the data bus lines to the desired logic level.

The PSD can replace the two buffers by configuring Ports F and G to operate in MCU Reset mode. In this mode, the PSD will drive the pre-defined logic level or data pattern on to the MCU data bus when Reset is active and there is no ongoing bus cycle. After reset, Ports F and G return to the normal Data Port mode.

The MCU Reset mode is enabled and configured in PSDsoft Express. The user defines the logic level (data pattern) that will be drive out from Ports F and G during reset.

Port Configuration Registers (PCR). Each Port has a set of Port Configuration Registers (PCR) used for configuration. The contents of the registers can be accessed by the MCU through normal read/write bus cycles at the addresses given in Table 6. The addresses in Table 6 are the offsets in hexadecimal from the base of the CSIOP register.

The pins of a port are individually configurable and each bit in the register controls its respective pin. For example, bit 0 in a register refers to bit 0 of its port. The three Port Configuration Registers (PCR), shown in Table 42, are used for setting the Port configurations. The default Power-up state for each register in Table 42 is 00h.

Table 42. Port Configuration Registers (PCR)

Register Name	Port	MCU Access
Control	E, F, G	Write/Read
Direction	A, B, C, D, E, F, G	Write/Read
Drive Select ¹	A, B, C, D, E, F, G	Write/Read

Note: 1. See Table 46 for Drive Register bit definition.

Control Register. Any bit reset to 0 in the Control Register sets the corresponding port pin to MCU I/O mode, and a 1 sets it to Address Out mode. The default mode is MCU I/O. Only Ports E, F and G have an associated Control Register.

Figure 28. Peripheral I/O Mode

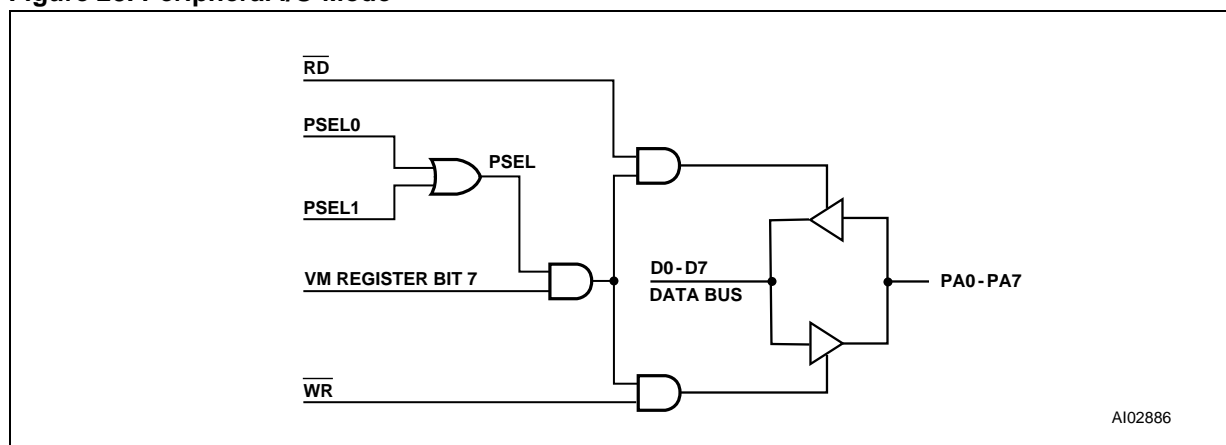

Direction Register. The Direction Register controls the direction of data flow in the I/O Ports. Any bit set to 1 in the Direction Register causes the corresponding pin to be an output, and any bit set to 0 causes it to be an input. The default mode for all port pins is input.

Table 43. Port Pin Direction Control, Output Enable P.T. Not Defined

Direction Register Bit	Port Pin Mode
0	Input
1	Output

Table 44. Port Pin Direction Control, Output Enable P.T. Defined

Direction Register Bit	Output Enable P.T.	Port Pin Mode
0	0	Input
0	1	Output
1	0	Output
1	1	Output

Table 45. Port Direction Assignment Example

Bit 7	Bit 6	Bit 5	Bit 4	Bit 3	Bit 2	Bit 1	Bit 0
0	0	0	0	0	1	1	1

Figure 29 and Figure 31 show the Port Architecture diagrams for Ports A/B/C and E/F/G, respectively. The direction of data flow for Ports A, B, C and F are controlled not only by the direction register, but also by the output enable product term from the PLD AND Array. If the output enable product term is not active, the Direction Register has sole control of a given pin's direction.

An example of a configuration for a Port with the three least significant bits set to output and the remainder set to input is shown in Table 45. Since Port D only contains four pins, the Direction Register for Port D has only the four least significant bits active.

Drive Select Register. The Drive Select Register configures the pin driver as Open Drain or CMOS for some port pins, and controls the slew rate for the other port pins. An external pull-up resistor should be used for pins configured as Open Drain.

A pin can be configured as Open Drain if its corresponding bit in the Drive Select Register is set to a 1. The default pin drive is CMOS.

(The slew rate is a measurement of the rise and fall times of an output. A higher slew rate means a faster output response and may create more electrical noise. A pin operates in a high slew rate when the corresponding bit in the Drive Register is set to 1. The default rate is slow slew.)

Table 46 shows the Drive Register for Ports A, B, C, D, E, F and G. It summarizes which pins can be configured as Open Drain outputs and which pins the slew rate can be set for.

Table 46. Drive Register Pin Assignment

Drive Register	Bit 7	Bit 6	Bit 5	Bit 4	Bit 3	Bit 2	Bit 1	Bit 0
Port A	Open Drain	Open Drain	Open Drain	Open Drain	Open Drain	Open Drain	Open Drain	Open Drain
Port B	Open Drain	Open Drain	Open Drain	Open Drain	Open Drain	Open Drain	Open Drain	Open Drain
Port C	Slew Rate	Slew Rate	Slew Rate	Slew Rate	Slew Rate	Slew Rate	Slew Rate	Slew Rate
Port D	NA ¹	NA ¹	NA ¹	NA ¹	Open Drain	Open Drain	Open Drain	Open Drain
Port E	Open Drain	Open Drain	Open Drain	Open Drain	Open Drain	Open Drain	Open Drain	Open Drain
Port F	Slew Rate	Slew Rate	Slew Rate	Slew Rate	Slew Rate	Slew Rate	Slew Rate	Slew Rate
Port G	Open Drain	Open Drain	Open Drain	Open Drain	Open Drain	Open Drain	Open Drain	Open Drain

Note: 1. NA = Not Applicable.

Table 47. Port Data Registers

Register Name	Port	MCU Access
Data In	A, B, C, D, E, F, G	Read – input on pin
Data Out	A, B, C, D, E, F, G	Write/Read
Output Macrocell	A, B	Read – outputs of Macrocells Write – loading Macrocells Flip-flop
Mask Macrocell	A, B	Write/Read – prevents loading into a given Macrocell
Input Macrocell	A, B, C	Read – outputs of the Input Macrocells
Enable Out	A, B, C, F	Read – the output enable control of the port driver

Port Data Registers. The Port Data Registers, shown in Table 47, are used by the MCU to write data to or read data from the ports. Table 47 shows the register name, the ports having each register type, and MCU access for each register type. The registers are described next.

Data In. Port pins are connected directly to the Data In buffer. In MCU I/O Input mode, the pin input is read through the Data In buffer.

Data Out Register. Stores output data written by the MCU in the MCU I/O Output mode. The contents of the Register are driven out to the pins if the Direction Register or the output enable product term is set to 1. The contents of the register can also be read back by the MCU.

Output Macrocells (OMC). The CPLD Output Macrocells (OMC) occupy a location in the MCU's address space. The MCU can read the output of

the Output Macrocells (OMC). If the Mask Macrocell Register bits are not set, writing to the Macrocell loads data to the Macrocell flip-flops. See the section entitled "Macrocell and I/O Port", on page 34.

Mask Macrocell Register. Each Mask Macrocell Register bit corresponds to an Output Macrocell (OMC) flip-flop. When the Mask Macrocell Register bit is set to a 1, loading data into the Output Macrocell (OMC) flip-flop is blocked. The default value is 0, or unblocked.

Input Macrocells (IMC). The Input Macrocells (IMC) can be used to latch or store external inputs. The outputs of the Input Macrocells (IMC) are routed to the PLD input bus, and can be read by the MCU. See the section entitled "Input Macrocells (IMC)", on page 37.

Figure 29. Port A, B and C Structure

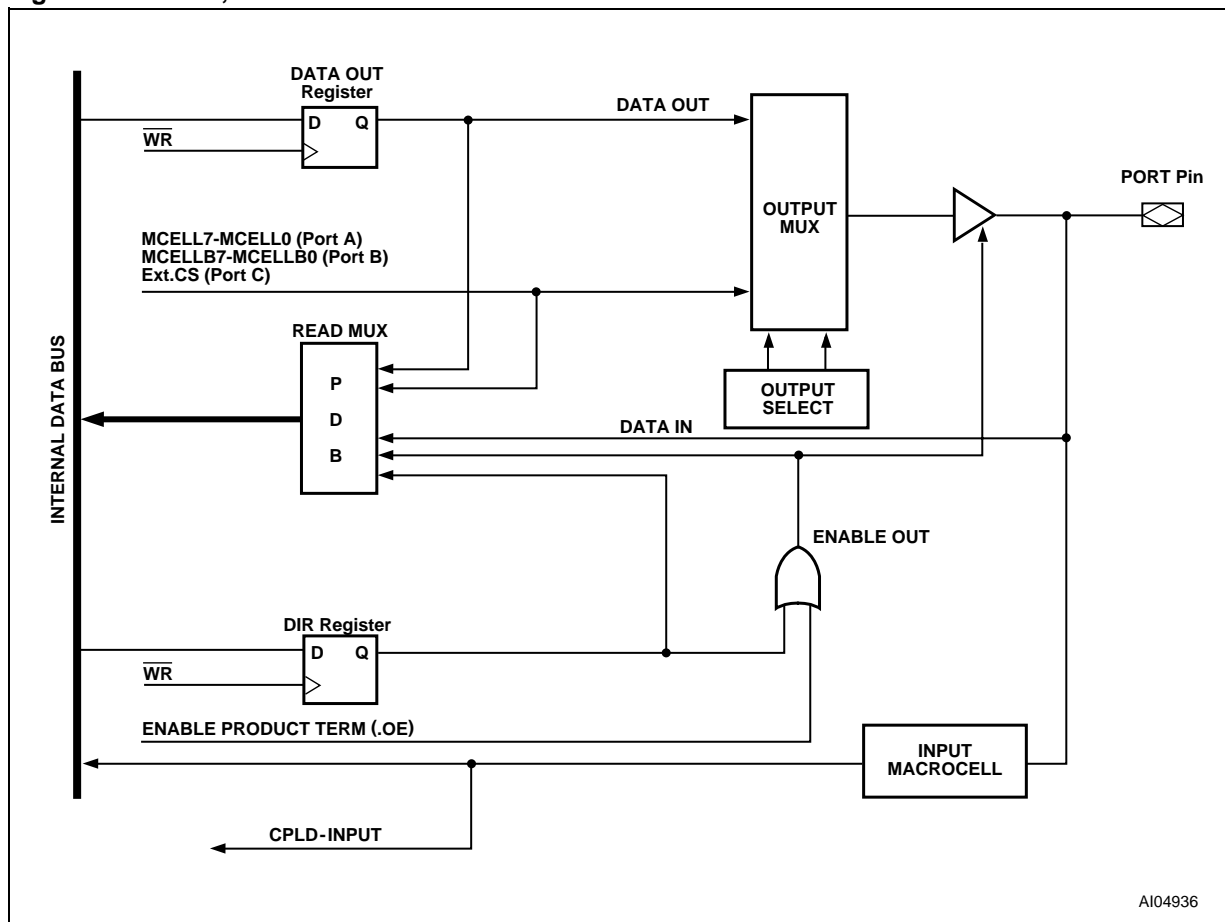

Enable Out. The Enable Out register can be read by the MCU. It contains the output enable values for a given port. A 1 indicates the driver is in output mode. A 0 indicates the driver is in tri-state and the pin is in input mode.

Ports A, B and C – Functionality and Structure

Ports A, B and C have similar functionality and structure, as shown in Figure 29. The ports can be configured to perform one or more of the following functions:

- MCU I/O Mode

- CPLD Output – Macrocells McellA7-McellA0 can be connected to Port A. McellB7-McellB0 can be connected to Port B. External Chip Select (ECS7-ECS0) can be connected to Port C or Port F.
- CPLD Input – Via the Input Macrocells (IMC).
- Address In – Additional high address inputs using the Input Macrocells (IMC).
- Open Drain/Slew Rate – pins PC7-PC0 can be configured to fast slew rate. Pins PA7-PA0 can be configured to Open Drain mode.

Figure 30. Port D Structure

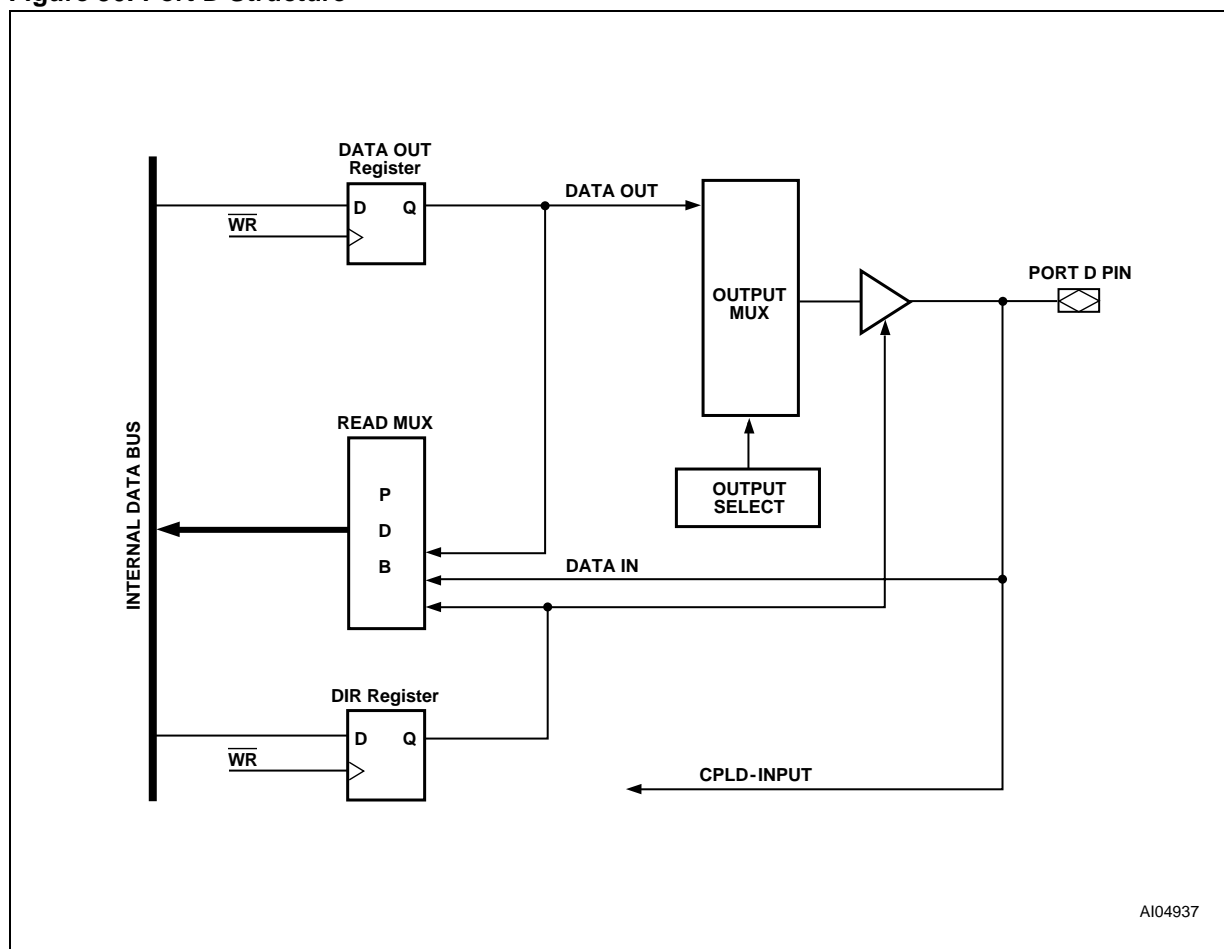

AI04937

Port D – Functionality and Structure

Port D has four I/O pins. See Figure 30. Port D can be configured to perform one or more of the following functions:

- MCU I/O mode
- CPLD Input – direct input to the CPLD, no Input Macrocells (IMC)

Port D pins can be configured in PSDsoft Express as input pins for other dedicated functions:

- Address Strobe (ALE/AS, PD0)
- CLKIN (PD1) as input to the Macrocells Flip-flops and APD counter
- PSD Chip Select Input ($\overline{\text{CSI}}$, PD2). Driving this signal High disables the Flash memory, SRAM and CSIOP.
- Write Enable High-byte ($\overline{\text{WRH}}$, PD3) input, or as DBE input from a MC68HC912.

Port E – Functionality and Structure

Port E can be configured to perform one or more of the following functions (see Figure 31):

- MCU I/O Mode
- In-System Programming (ISP) – JTAG port can be enabled for programming/erase of the PSD device. (See the section entitled “Reset (RESET) Timing”, on page 63, for more information on JTAG programming.)
- Open Drain – pins can be configured in Open Drain Mode
- Battery Backup features
 - PE6 can be configured for a battery input supply, Voltage Stand-by (VSTBY).
 - PE7 can be configured as a Battery-on Indicator (VBATON), indicating when V_{CC} is less than V_{BAT} .
- Latched Address output – Provide latched address output.

Figure 31. Port E, F and G Structure

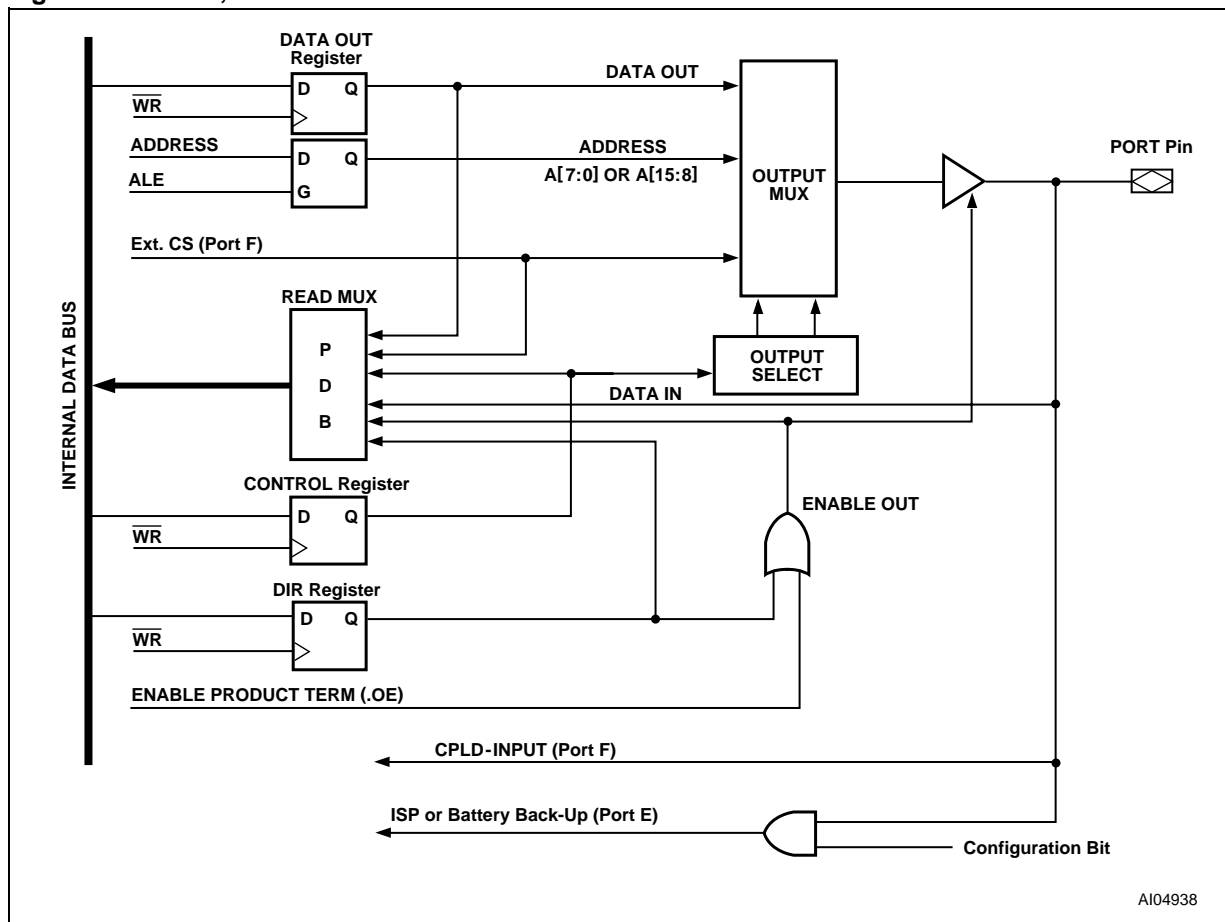

Port F – Functionality and Structure

Port F can be configured to perform one or more of the following functions:

- MCU I/O Mode
- CPLD Output – External Chip Select (ECS7-ECS0) can be connected to Port F or Port C.
- CPLD Input – direct input to the CPLD, no Input Macrocells (IMC)
- Latched Address output – Provide latched address output as per Table 41.
- Slew Rate – pins can be configured for fast Slew Rate
- Data Port – connected to D7-D0 when Port F is configured as Data Port for a non-multiplexed bus
- Peripheral Mode

- MCU Reset Mode – for 16-bit Motorola 683xx and HC16 MCUs

Port G – Functionality and Structure

Port G can be configured to perform one or more of the following functions:

- MCU I/O Mode
- Latched Address output – Provide latched address output as per Table 41.
- Open Drain – pins can be configured in Open Drain Mode
- Data Port – connected to D15-D8 when Port G is configured as Data Port for a non-multiplexed bus
- MCU Reset Mode – for 16-bit Motorola 683xx and HC16 MCUs

POWER MANAGEMENT

The PSD device offers configurable power saving options. These options may be used individually or in combinations, as follows:

- All memory blocks in a PSD (primary Flash memory, secondary Flash memory, and SRAM) are built with power management technology. In addition to using special silicon design methodology, power management technology puts the memories into standby mode when address/data inputs are not changing (zero DC current). As soon as a transition occurs on an input, the affected memory “wakes up”, changes and latches its outputs, then goes back to standby. The designer does *not* have to do anything special to achieve memory Stand-by mode when no inputs are changing—it happens automatically.

The PLD sections can also achieve Stand-by mode when its inputs are not changing, as described for the Power Management Mode Registers (PMMR), later.

- The Automatic Power Down (APD) block allows the PSD to reduce to stand-by current automatically. The APD Unit also blocks MCU address/data signals from reaching the memories and PLDs. This feature is available on all PSD devices. The APD Unit is described in more detail in the section entitled “APD Unit”, on page 60.

Built in logic monitors the Address Strobe of the MCU for activity. If there is no activity for a certain period (the MCU is asleep), the APD Unit initiates Power-down mode (if enabled). Once in Power-down mode, all address/data signals are blocked from reaching the PSD memories and PLDs, and the memories are deselected internally. This allows the memories and PLDs to remain in Stand-by mode even if the address/data signals are changing state externally (noise, other devices on the MCU bus, etc.). Keep in

mind that any unblocked PLD input signals that are changing states keeps the PLD out of Stand-by mode, but not the memories.

- PSD Chip Select Input ($\overline{\text{CSI}}$, PD2) can be used to disable the internal memories, placing them in Stand-by mode even if inputs are changing. This feature does not block any internal signals or disable the PLDs. This is a good alternative to using the APD Unit, especially if your MCU has a chip select output. There is a slight penalty in memory access time when PSD Chip Select Input ($\overline{\text{CSI}}$, PD2) makes its initial transition from deselected to selected.
- The Power Management Mode Registers (PMMR) can be written by the MCU at run-time to manage power. All PSD devices support “blocking bits” in these registers that are set to block designated signals from reaching both PLDs. Current consumption of the PLDs is directly related to the composite frequency of the changes on their inputs (see Figure 35).

Significant power savings can be achieved by blocking signals that are not used in DPLD or CPLD logic equations at run-time. PSDsoft Express creates a fuse map that automatically blocks the low address byte (A7-A0) or the control signals (CNTL0-CNTL2, ALE and Write Enable High-byte ($\overline{\text{WRH/DBE}}$, PD3)) if none of these signals are used in PLD logic equations.

PSD devices have a Turbo bit in PMMR0. This bit can be set to turn the Turbo mode off (the default is with Turbo mode turned on). While Turbo mode is off, the PLDs can achieve Stand-by current when no PLD inputs are changing (zero DC current). Even when inputs do change, significant power can be saved at lower frequencies (AC current), compared to when Turbo mode is on. When the Turbo mode is on, there is a significant DC current component, and the AC component is higher.

Figure 32. APD Unit

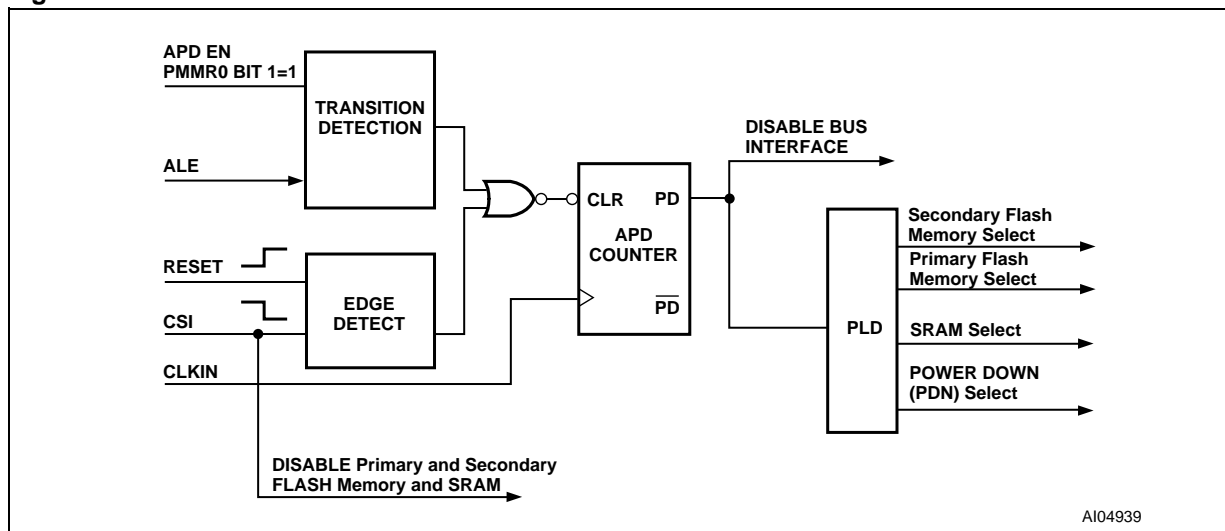

Automatic Power-down (APD) Unit and Power-down Mode. The APD Unit, shown in Figure 32, puts the PSD into Power-down mode by monitoring the activity of Address Strobe (ALE/AS, PD0). If the APD Unit is enabled, as soon as activity on Address Strobe (ALE/AS, PD0) stops, a four bit counter starts counting. If Address Strobe (ALE/AS, PD0) remains inactive for fifteen clock periods of CLKIN (PD1), Power-down (PDN) goes High, and the PSD enters Power-down mode, as discussed next.

Table 48. Effect of Power-down Mode on Ports

Port Function	Pin Level
MCU I/O	No Change
PLD Out	No Change
Address Out	Undefined
Data Port	Tri-State
Peripheral I/O	Tri-State

Power-down Mode. By default, if you enable the APD Unit, Power-down mode is automatically enabled. The device enters Power-down mode if Address Strobe (ALE/AS, PD0) remains inactive for fifteen periods of CLKIN (PD1).

The following should be kept in mind when the PSD is in Power-down mode:

- If Address Strobe (ALE/AS, PD0) starts pulsing again, the PSD returns to normal operation. The PSD also returns to normal operation if either PSD Chip Select Input (\overline{CSI} , PD2) is Low or the Reset (\overline{RESET}) input is High.
- The MCU address/data bus is blocked from all memory and PLDs.
- Various signals can be blocked (prior to Power-down mode) from entering the PLDs by setting the appropriate bits in the Power Management Mode Registers (PMMR). The blocked signals include MCU control signals and the common CLKIN (PD1). Note that blocking CLKIN (PD1) from the PLDs does not block CLKIN (PD1) from the APD Unit.
- All PSD memories enter Stand-by mode and are drawing Stand-by current. However, the PLDs and I/O ports blocks do *not* go into Stand-by mode because you do not want to have to wait for the logic and I/O to “wake-up” before their outputs can change. See Table 48 for Power-down mode effects on PSD ports.
- Typical Stand-by current is or the order of μA . This Stand-by current value assumes that there are no transitions on any PLD input.

Table 49. PSD Timing and Stand-by Current during Power-down Mode

Mode	PLD Propagation Delay	Memory Access Time	Access Recovery Time to Normal Access	Typical Stand-by Current
Power-down	Normal t_{PD} (Note ¹)	No Access	t_{LVDV}	I_{SB} (Note ²)

Note: 1. Power-down does not affect the operation of the PLD. The PLD operation in this mode is based only on the Turbo bit.
 2. Typical current consumption, see Table 60, assuming no PLD inputs are changing state and the PLD Turbo bit is 0.

Figure 33. Enable Power-down Flow Chart

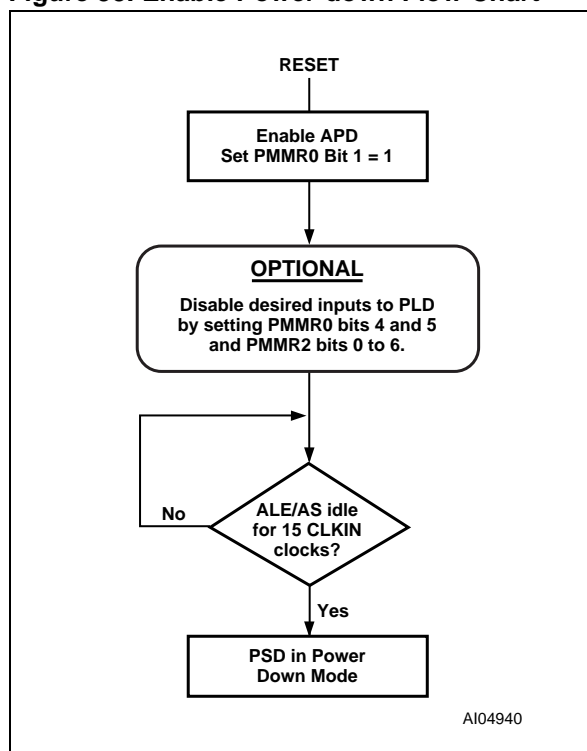

Other Power Saving Options. The PSD offers other reduced power saving options that are independent of the Power-down mode. Except for the SRAM Stand-by and PSD Chip Select Input ($\overline{\text{CSI}}$, PD2) features, they are enabled by setting bits in PMMR0 and PMMR2 (as summarised in Table 23 and Table 24).

PLD Power Management

The power and speed of the PLDs are controlled by the Turbo bit (bit 3) in PMMR0. By setting the bit to 1, the Turbo mode is off and the PLDs consume the specified Stand-by current when the inputs are not switching for an extended time of 70 ns. The propagation delay time is increased after the Turbo bit is set to 1 (turned off) when the inputs change at a composite frequency of less than 15 MHz. When the Turbo bit is reset to 0 (turned on), the PLDs run at full power and speed. The Turbo bit affects the PLD's DC power, AC power,

and propagation delay. See the AC and DC characteristics tables for PLD timing values (Table 67). Blocking MCU control signals with the PMMR2 bits can further reduce PLD AC power consumption.

SRAM Stand-by Mode (Battery Backup). The PSD supports a battery backup mode in which the contents of the SRAM are retained in the event of a power loss. The SRAM has Voltage Stand-by (VSTBY, PE6) that can be connected to an external battery. When V_{CC} becomes lower than V_{STBY} then the PSD automatically connects to Voltage Stand-by (VSTBY, PE6) as a power source to the SRAM. The SRAM Stand-by current (I_{STBY}) is typically 0.5 μA . The SRAM data retention voltage is 2 V minimum. The Battery-on Indicator (VBATON) can be routed to PE7. This signal indicates when the V_{CC} has dropped below V_{STBY} , and that the SRAM is running on battery power.

PSD Chip Select Input ($\overline{\text{CSI}}$, PD2)

PD2 of Port D can be configured in PSDsoft Express as PSD Chip Select Input ($\overline{\text{CSI}}$). When Low, the signal selects and enables the internal primary Flash memory, secondary Flash memory, SRAM, and I/O blocks for Read or Write operations involving the PSD. A High on PSD Chip Select Input ($\overline{\text{CSI}}$, PD2) disables the primary Flash memory, secondary Flash memory, and SRAM, and reduces the PSD power consumption. However, the PLD and I/O signals remain operational when PSD Chip Select Input ($\overline{\text{CSI}}$, PD2) is High.

There may be a timing penalty when using PSD Chip Select Input ($\overline{\text{CSI}}$, PD2) depending on the speed grade of the PSD that you are using. See the timing parameter t_{SLQV} in Table 67.

Input Clock. The PSD provides the option to turn off CLKIN (PD1) to the PLD to save AC power consumption. CLKIN (PD1) is an input to the PLD AND Array and the Output Macrocells (OMC).

During Power-down mode, or, if CLKIN (PD1) is not being used as part of the PLD logic equation, the clock should be disabled to save AC power. CLKIN (PD1) is disconnected from the PLD AND Array or the Macrocells block by setting bits 4 or 5 to a 1 in PMMR0.

Table 50. APD Counter Operation

APD Enable Bit	ALE PD Polarity	ALE Level	APD Counter
0	X	X	Not Counting
1	X	Pulsing	Not Counting
1	1	1	Counting (Generates PDN after 15 Clocks)
1	0	0	Counting (Generates PDN after 15 Clocks)

Input Control Signals. The PSD provides the option to turn off the address input (A7-A0) and input control signals (CNTL0, CNTL1, CNTL2, Address Strobe (ALE/AS, PD0) and Write Enable High-byte (WRH/DBE, PD3)) to the PLD to save AC power consumption. These signals are inputs to the PLD AND Array. During Power-down mode, or, if any of them are not being used as part of the PLD logic equation, these control signals should be disabled to save AC power. They are disconnected from the PLD AND Array by setting bits 0, 2, 3, 4, 5 and 6 to a 1 in PMMR2.

Power On Reset, Warm Reset and Power-down

Power On Reset. Upon Power-up, the PSD requires a Reset (RESET) pulse of duration $t_{NLNH-PO}$ (minimum 1 ms) after V_{CC} is steady. During this period, the device loads internal configurations, clears some of the registers and sets the Flash memory into Operating mode. After the rising edge of Reset (RESET), the PSD remains in the Reset mode for an additional period, t_{OPR} (maximum 120 ns), before the first memory access is allowed.

The PSD Flash memory is reset to the Read mode upon Power-up. Sector Select (FS0-FS7 and CSBOOT0-CSBOOT3) must all be Low, Write Strobe ($\overline{WR/WRL}$, CNTL0) High, during Power On Reset for maximum security of the data contents and to remove the possibility of data being written

on the first edge of Write Strobe ($\overline{WR/WRL}$, CNTL0). Any Flash memory Write cycle initiation is prevented automatically when V_{CC} is below V_{LKO} .

Warm Reset. Once the device is up and running, the device can be reset with a pulse of a much shorter duration, t_{NLNH} (minimum 150 ns). The same t_{OPR} period is needed before the device is operational after warm reset. Figure 34 shows the timing of the Power-up and warm reset.

I/O Pin, Register and PLD Status at Reset. Table 51 shows the I/O pin, register and PLD status during Power On Reset, warm reset and Power-down mode. PLD outputs are always valid during warm reset, and they are valid in Power On Reset once the internal PSD Configuration bits are loaded. This loading of PSD is completed typically long before the V_{CC} ramps up to operating level. Once the PLD is active, the state of the outputs are determined by equations specified in PSDsoft Express.

Reset of Flash Memory Erase and Program Cycles. An external Reset (RESET) also resets the internal Flash memory state machine. During a Flash memory Program or Erase cycle, Reset (RESET) terminates the cycle and returns the Flash memory to the Read mode within a period of t_{NLNH-A} (minimum 25 μ s).

Table 51. Status During Power-On Reset, Warm Reset and Power-down Mode

Port Configuration	Power-On Reset	Warm Reset	Power-down Mode
MCU I/O	Input mode	Input mode	Unchanged
PLD Output	Valid after internal PSD configuration bits are loaded	Valid	Depends on inputs to PLD (addresses are blocked in PD mode)
Address Out	Tri-stated	Tri-stated	Not defined
Data Port	Tri-stated	Tri-stated	Tri-stated
Peripheral I/O	Tri-stated	Tri-stated	Tri-stated

Register	Power-On Reset	Warm Reset	Power-down Mode
PMMR0 and PMMR2	Cleared to 0	Unchanged	Unchanged
Macrocells Flip-flop status	Cleared to 0 by internal Power-On Reset	Depends on .re and .pr equations	Depends on .re and .pr equations
VM Register ¹	Initialized, based on the selection in PSDsoft Express Configuration menu	Initialized, based on the selection in PSDsoft Express Configuration menu	Unchanged
All other registers	Cleared to 0	Cleared to 0	Unchanged

Note: 1. The SR_code and Peripheral Mode bits in the VM Register are always cleared to 0 on Power-On Reset or Warm Reset.

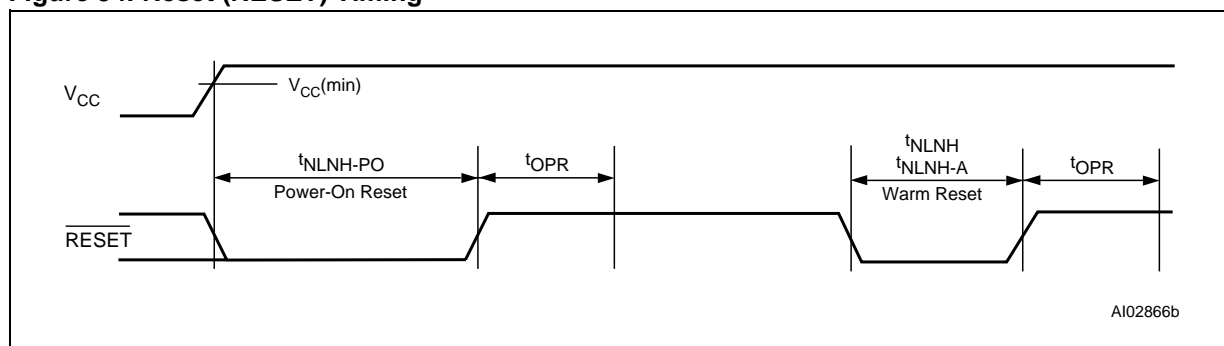

Figure 34. Reset ($\overline{\text{RESET}}$) Timing

Programming In-Circuit using the JTAG Serial Interface

The JTAG Serial Interface on the PSD can be enabled on Port E (see Table 52). All memory blocks (primary Flash memory and secondary Flash memory), PLD logic, and PSD Configuration bits may be programmed through the JTAG-ISC Serial Interface. A blank device can be mounted on a printed circuit board and programmed using JTAG In-System Programming (ISP).

The standard JTAG signals (IEEE 1149.1) are TMS, TCK, TDI, and TDO. Two additional signals, TSTAT and $\overline{\text{TERR}}$, are optional JTAG extensions used to speed up Program and Erase cycles.

By default, on a blank PSD (as shipped from the factory, or after erasure), four pins on Port E are enabled for the basic JTAG signals TMS, TCK, TDI, and TDO.

See Application Note AN1153 for more details on JTAG In-System Programming (ISP).

Standard JTAG Signals. The standard JTAG signals (TMS, TCK, TDI, and TDO) can be enabled by any of three different conditions that are logically ORed. When enabled, TDI, TDO, TCK, and TMS are inputs, waiting for a serial command from an external JTAG controller device (such as FlashLINK or Automated Test Equipment). When the enabling command is received from the external JTAG controller device, TDO becomes an output and the JTAG channel is fully functional inside the PSD. The same command that enables the JTAG channel may optionally enable the two additional JTAG pins, TSTAT and $\overline{\text{TERR}}$.

The following symbolic logic equation specifies the conditions enabling the four basic JTAG pins (TMS, TCK, TDI, and TDO) on their respective Port E pins. For purposes of discussion, the logic label JTAG_ON is used. When JTAG_ON is true, the four pins are enabled for JTAG. When JTAG_ON is false, the four pins can be used for general PSD I/O.

```
JTAG_ON = PSDsoft_Express_enabled +
/* An NVM configuration bit inside the
PSD is set by the designer in the
PSDsoft_Express Configuration utility.
```

```
This dedicates the pins for JTAG at all
times (compliant with IEEE 1149.1 */
Microcontroller_enabled +
/* The microcontroller can set a bit at
run-time by writing to the PSD
register, JTAG Enable. This register
is located at address CSIOP + offset
C7h. Setting the JTAG_ENABLE bit in
this register will enable the pins for
JTAG use. This bit is cleared by a PSD
reset or the microcontroller. See
Table 21 for bit definition. */
PSD_product_term_enabled;
/* A dedicated product term (PT) inside
the PSD can be used to enable the JTAG
pins. This PT has the reserved name
JTAGSEL. Once defined as a node in
PSDabel, the designer can write an
equation for JTAGSEL. This method is
used when the Port E JTAG pins are
multiplexed with other I/O signals. It
is recommended to tie logically the
node JTAGSEL to the JEN\ signal on the
Flashlink cable when multiplexing JTAG
signals. See Application Note 1153 for
details. */
```

The state of the PSD Reset ($\overline{\text{RESET}}$) signal does not interrupt (or prevent) JTAG operations if the JTAG pins are dedicated by an NVM configuration bit (via PSDsoft Express). However, Reset ($\overline{\text{RESET}}$) will prevent or interrupt JTAG operations if the JTAG Enable Register (as shown in Table 21) is used to enable the JTAG pins.

The PSD supports JTAG In-System-Programmability (ISP) commands, but not Boundary Scan. ST's PSDsoft Express software tool and FlashLINK JTAG programming cable implement the JTAG In-System-Programmability (ISP) commands.

Table 52. JTAG Port Signals

Port E Pin	JTAG Signals	Description
PE0	TMS	Mode Select
PE1	TCK	Clock
PE2	TDI	Serial Data In
PE3	TDO	Serial Data Out

Port E Pin	JTAG Signals	Description
PE4	TSTAT	Status
PE5	\overline{TERR}	Error Flag

JTAG Extensions. TSTAT and \overline{TERR} are two JTAG extension signals enabled by a JTAG command received over the four standard JTAG pins (TMS, TCK, TDI, and TDO). They are used to speed Program and Erase cycles by indicating status on PSD pins instead of having to scan the status out serially using the standard JTAG channel. See Application Note AN1153.

\overline{TERR} indicates if an error has occurred when erasing a sector or programming in Flash memory. This signal goes Low (active) when an Error condition occurs, and stays Low until a specific JTAG command is executed or a Reset (\overline{RESET}) pulse is received after an "ISC_DISABLE" command.

TSTAT behaves the same as Ready/ \overline{Busy} (PE4) described in the section entitled "Ready/Busy (PE4)", on page 21. TSTAT is High when the PSD4235G2 device is in Read mode (primary Flash memory and secondary Flash memory contents can be read). TSTAT is Low when Flash memory Program or Erase cycles are in progress,

INITIAL DELIVERY STATE

When delivered from ST, the PSD device has all bits in the memory and PLDs set to 1. The PSD Configuration Register bits are set to 0. The code, configuration, and PLD logic are loaded using the

and also when data is being written to the secondary Flash memory .

TSTAT and \overline{TERR} can be configured as open-drain type signals with a JTAG command.

Note: The state of Reset (\overline{Reset}) does not interrupt (or prevent) JTAG operations if the JTAG signals are dedicated by an NVM Configuration bit (via PSDsoft Express). However, Reset (\overline{Reset}) prevents or interrupts JTAG operations if the JTAG Enable Register (as shown in Table 21) is used to enable the JTAG signals.

Security and Flash memory Protection. When the security bit is set, the device cannot be read on a Device Programmer or through the JTAG Port. When using the JTAG Port, only a Full Chip Erase command is allowed.

All other Program, Erase and Verify commands are blocked. Full Chip Erase returns the device to a non-secured blank state. The Security Bit can be set in PSDsoft Express.

All primary Flash memory and secondary Flash memory sectors can individually be sector protected against erasure. The sector protect bits can be set in PSDsoft Express.

programming procedure. Information for programming the device is available directly from ST. Please contact your local sales representative.



AC/DC PARAMETERS

These tables describe the AD and DC parameters of the PSD4235G2:

- DC Electrical Specification
- AC Timing Specification
- PLD Timing
 - Combinatorial Timing
 - Synchronous Clock Mode
 - Asynchronous Clock Mode
 - Input Macrocell Timing
- MCU Timing
 - Read Timing
 - Write Timing
 - Peripheral Mode Timing

- Power-down and Reset Timing

The following are issues concerning the parameters presented:

- In the DC specification the supply current is given for different modes of operation. Before calculating the total power consumption, determine the percentage of time that the PSD is in each mode. Also, the supply power is considerably different if the Turbo bit is 0.
- The AC power component gives the PLD, Flash memory, and SRAM mA/MHz specification. Figure 35 show the PLD mA/MHz as a function of the number of Product Terms (PT) used.
- In the PLD timing parameters, add the required delay when Turbo bit is 0.

Figure 35. PLD I_{CC} /Frequency Consumption

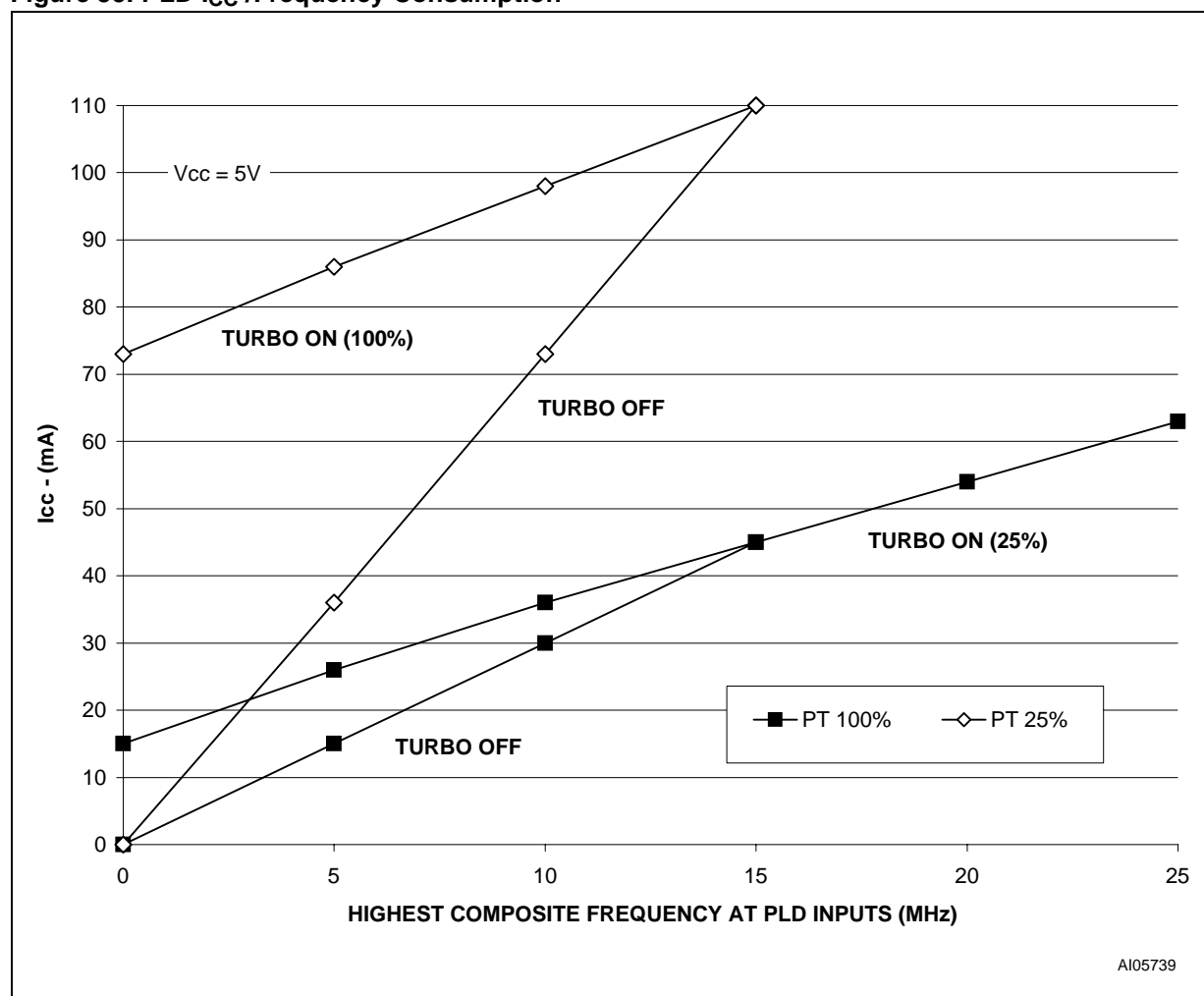

Table 53. Example of PSD Typical Power Calculation at V_{CC} = 5.0 V (with Turbo Mode On)

Conditions	
Highest Composite PLD input frequency (Freq PLD)	= 8 MHz
MCU ALE frequency (Freq ALE)	= 4 MHz
% Flash memory Access	= 80%
% SRAM access	= 15%
% I/O access	= 5% (no additional power above base)
Operational Modes	
% Normal	= 10%
% Power-down Mode	= 90%
Number of product terms used	
(from fitter report)	= 45 PT
% of total product terms	= 45/193 = 23.3%
Turbo Mode	= ON
Calculation (using typical values)	
I _{CC} total	$= I_{pwrdown} \times \%pwrdown + \%normal \times (I_{CC} (ac) + I_{CC} (dc))$ $= I_{pwrdown} \times \%pwrdown + \%normal \times (\%flash \times 2.5 \text{ mA/MHz} \times \text{Freq ALE}$ $+ \%SRAM \times 1.5 \text{ mA/MHz} \times \text{Freq ALE}$ $+ \%PLD \times 2 \text{ mA/MHz} \times \text{Freq PLD}$ $+ \#PT \times 400 \mu\text{A/PT})$ $= 50 \mu\text{A} \times 0.90 + 0.1 \times (0.8 \times 2.5 \text{ mA/MHz} \times 4 \text{ MHz}$ $+ 0.15 \times 1.5 \text{ mA/MHz} \times 4 \text{ MHz}$ $+ 2 \text{ mA/MHz} \times 8 \text{ MHz}$ $+ 45 \times 0.4 \text{ mA/PT})$ $= 45 \mu\text{A} + 0.1 \times (8 + 0.9 + 16 + 18 \text{ mA})$ $= 45 \mu\text{A} + 0.1 \times 42.9$ $= 45 \mu\text{A} + 4.29 \text{ mA}$ $= 4.34 \text{ mA}$
<p>This is the operating power with no Flash memory Program or Erase cycles in progress. Calculation is based on I_{OUT} = 0 mA.</p>	

Table 54. Example of PSD Typical Power Calculation at V_{CC} = 5.0 V (with Turbo Mode Off)

Conditions	
Highest Composite PLD input frequency (Freq PLD)	= 8 MHz
MCU ALE frequency (Freq ALE)	= 4 MHz
% Flash memory Access	= 80%
% SRAM access	= 15%
% I/O access	= 5% (no additional power above base)
Operational Modes	
% Normal	= 10%
% Power-down Mode	= 90%
Number of product terms used	
(from fitter report)	= 45 PT
% of total product terms	= 45/193 = 23.3%
Turbo Mode	= Off
Calculation (using typical values)	
I _{CC} total	$= I_{pwrdown} \times \%pwrdown + \%normal \times (I_{CC} (ac) + I_{CC} (dc))$ $= I_{pwrdown} \times \%pwrdown + \%normal \times (\%flash \times 2.5 \text{ mA/MHz} \times \text{Freq ALE}$ $\quad + \%SRAM \times 1.5 \text{ mA/MHz} \times \text{Freq ALE}$ $\quad + \%PLD \times (\text{from graph using Freq PLD}))$ $= 50 \mu\text{A} \times 0.90 + 0.1 \times (0.8 \times 2.5 \text{ mA/MHz} \times 4 \text{ MHz}$ $\quad + 0.15 \times 1.5 \text{ mA/MHz} \times 4 \text{ MHz}$ $\quad + 24 \text{ mA})$ $= 45 \mu\text{A} + 0.1 \times (8 + 0.9 + 24)$ $= 45 \mu\text{A} + 0.1 \times 32.9$ $= 45 \mu\text{A} + 3.29 \text{ mA}$ $= 3.34 \text{ mA}$
This is the operating power with no Flash memory Program or Erase cycles in progress. Calculation is based on I _{OUT} = 0 mA.	

MAXIMUM RATING

Stressing the device above the rating listed in the Absolute Maximum Ratings" table may cause permanent damage to the device. These are stress ratings only and operation of the device at these or any other conditions above those indicated in the Operating sections of this specification is not im-

plied. Exposure to Absolute Maximum Rating conditions for extended periods may affect device reliability. Refer also to the STMicroelectronics SURE Program and other relevant quality documents.

Table 55. Absolute Maximum Ratings

Symbol	Parameter	Min.	Max.	Unit
T _{STG}	Storage Temperature	-65	125	°C
T _{LEAD}	Lead Temperature during Soldering (20 seconds max.) ¹		235	°C
V _{IO}	Input and Output Voltage (Q = V _{OH} or Hi-Z)	-0.6	7.0	V
V _{CC}	Supply Voltage	-0.6	7.0	V
V _{PP}	Device Programmer Supply Voltage	-0.6	14.0	V
V _{ESD}	Electrostatic Discharge Voltage (Human Body model) ²	-2000	2000	V

Note: 1. IPC/JEDEC J-STD-020A
 2. JEDEC Std JESD22-A114A (C1=100 pF, R1=1500 Ω, R2=500 Ω)

DC AND AC PARAMETERS

This section summarizes the operating and measurement conditions, and the DC and AC characteristics of the device. The parameters in the DC and AC Characteristic tables that follow are derived from tests performed under the Measure-

ment Conditions summarized in the relevant tables. Designers should check that the operating conditions in their circuit match the measurement conditions when relying on the quoted parameters.

Table 56. Operating Conditions

Symbol	Parameter	Min.	Max.	Unit
V _{CC}	Supply Voltage	4.5	5.5	V
T _A	Ambient Operating Temperature (industrial)	-40	85	°C
	Ambient Operating Temperature (commercial)	0	70	°C

Table 57. AC Symbols for PLD Timing

Signal Letters	
A	Address Input
C	CEout Output
D	Input Data
E	E Input
G	Internal WDOG_ON signal
I	Interrupt Input
L	ALE Input
N	Reset Input or Output
P	Port Signal Output
Q	Output Data
R	\overline{WR} , \overline{UDS} , \overline{LDS} , \overline{DS} , IORD, \overline{PSEN} Inputs
S	Chip Select Input
T	R/\overline{W} Input
W	Internal PDN Signal
B	V _{STBY} Output
M	Output Macrocell

Signal Behavior	
t	Time
L	Logic Level Low or ALE
H	Logic Level High
V	Valid
X	No Longer a Valid Logic Level
Z	Float
PW	Pulse Width

Example: t_{AVLX} – Time from Address Valid to ALE Invalid.

Table 58. AC Measurement Conditions

Symbol	Parameter	Min.	Max.	Unit
C_L	Load Capacitance	30		pF

Note: 1. Output Hi-Z is defined as the point where data out is no longer driven.

Table 59. Capacitance

Symbol	Parameter	Test Condition	Typ. ²	Max.	Unit
C_{IN}	Input Capacitance (for input pins)	$V_{IN} = 0V$	4	6	pF
C_{OUT}	Output Capacitance (for input/output pins)	$V_{OUT} = 0V$	8	12	pF
C_{VPP}	Capacitance (for CNTL2/ V_{PP})	$V_{PP} = 0V$	18	25	pF

Note: 1. Sampled only, not 100% tested.

2. Typical values are for $T_A = 25^\circ C$ and nominal supply voltages.

Figure 36. AC Measurement I/O Waveform

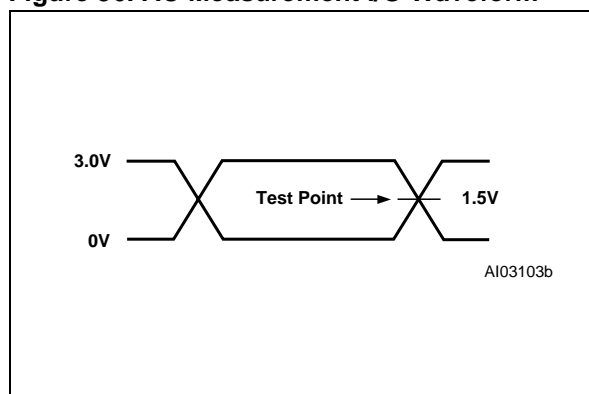

Figure 37. AC Measurement Load Circuit

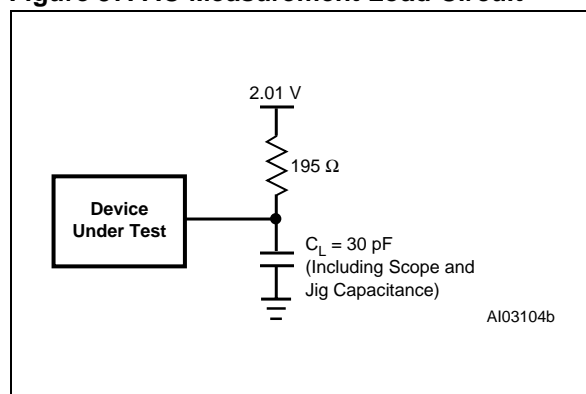

Figure 38. Switching Waveforms – Key

WAVEFORMS	INPUTS	OUTPUTS
	STEADY INPUT	STEADY OUTPUT
	MAY CHANGE FROM HI TO LO	WILL BE CHANGING FROM HI TO LO
	MAY CHANGE FROM LO TO HI	WILL BE CHANGING LO TO HI
	DON'T CARE	CHANGING, STATE UNKNOWN
	OUTPUTS ONLY	CENTER LINE IS TRI-STATE

AI03102

Table 60. DC Characteristics

Symbol	Parameter		Test Condition (in addition to those in Table 56)	Min.	Typ.	Max.	Unit
V _{IH}	Input High Voltage		4.5 V < V _{CC} < 5.5 V	2		V _{CC} + 0.5	V
V _{IL}	Input Low Voltage		4.5 V < V _{CC} < 5.5 V	-0.5		0.8	V
V _{IH1}	Reset High Level Input Voltage		(Note 1)	0.8V _{CC}		V _{CC} + 0.5	V
V _{IL1}	Reset Low Level Input Voltage		(Note 1)	-0.5		0.2V _{CC} - 0.1	V
V _{HYS}	Reset Pin Hysteresis			0.3			V
V _{LKO}	V _{CC} (min) for Flash Erase and Program			2.5		4.2	V
V _{OL}	Output Low Voltage		I _{OL} = 20 μA, V _{CC} = 4.5 V		0.01	0.1	V
			I _{OL} = 8 mA, V _{CC} = 4.5 V		0.25	0.45	V
V _{OH}	Output High Voltage Except V _{STBY} On		I _{OH} = -20 μA, V _{CC} = 4.5 V	4.4	4.49		V
			I _{OH} = -2 mA, V _{CC} = 4.5 V	2.4	3.9		V
V _{OH1}	Output High Voltage V _{STBY} On		I _{OH1} = 1 μA	V _{STBY} - 0.8			V
V _{STBY}	SRAM Stand-by Voltage			2.0		V _{CC}	V
I _{STBY}	SRAM Stand-by Current		V _{CC} = 0 V		0.5	1	μA
I _{IDLE}	Idle Current (V _{STBY} input)		V _{CC} > V _{STBY}	-0.1		0.1	μA
V _{DF}	SRAM Data Retention Voltage		Only on V _{STBY}	2			V
I _{SB}	Stand-by Supply Current for Power-down Mode		$\overline{CS1} > V_{CC} - 0.3$ V (Notes 2,3)		100	200	μA
I _{LI}	Input Leakage Current		V _{SS} < V _{IN} < V _{CC}	-1	±0.1	1	μA
I _{LO}	Output Leakage Current		0.45 < V _{OUT} < V _{CC}	-10	±5	10	μA
I _{CC} (DC) (Note 5)	Operating Supply Current	PLD Only	PLD_TURBO = Off, f = 0 MHz (Note 5)		0		μA/PT
			PLD_TURBO = On, f = 0 MHz		400	700	μA/PT
		Flash memory	During Flash memory Write/Erase Only		15	30	mA
			Read Only, f = 0 MHz		0	0	mA
SRAM	f = 0 MHz		0	0	mA		
I _{CC} (AC) (Note 5)	PLD AC Adder					note 4	
	Flash memory AC Adder				2.5	3.5	mA/MHz
	SRAM AC Adder				1.5	3.0	mA/MHz

Note: 1. Reset (Reset) has hysteresis. V_{IL1} is valid at or below 0.2V_{CC} - 0.1. V_{IH1} is valid at or above 0.8V_{CC}.

2. $\overline{CS1}$ deselected or internal Power-down mode is active.

3. PLD is in non-Turbo mode, and none of the inputs are switching.

4. Please see Figure 35 for the PLD current calculation.

Table 61. CPLD Combinatorial Timing

Symbol	Parameter	Conditions	-70		-90		Fast PT Alloc	Turbo Off	Slew rate ¹	Unit
			Min	Max	Min	Max				
t _{PD}	CPLD Input Pin/ Feedback to CPLD Combinatorial Output			20		25	+ 2	+ 12	- 2	ns
t _{EA}	CPLD Input to CPLD Output Enable			21		26		+ 12	- 2	ns
t _{ER}	CPLD Input to CPLD Output Disable			21		26		+ 12	- 2	ns
t _{ARP}	CPLD Register Clear or Preset Delay			21		26		+ 12	- 2	ns
t _{ARPW}	CPLD Register Clear or Preset Pulse Width		10		20			+ 12		ns
t _{ARD}	CPLD Array Delay	Any Macrocell		11		16	+ 2			ns

Note: 1. Fast Slew Rate output available on Port C and Port F.

Table 62. CPLD Macrocell Synchronous Clock Mode Timing

Symbol	Parameter	Conditions	-70		-90		Fast PT Alloc	Turbo Off	Slew rate ¹	Unit
			Min	Max	Min	Max				
f _{MAX}	Maximum Frequency External Feedback	1/(t _s +t _{CO})		34.4		30.30				MHz
	Maximum Frequency Internal Feedback (f _{CNT})	1/(t _s +t _{CO} -10)		52.6		43.48				MHz
	Maximum Frequency Pipelined Data	1/(t _{CH} +t _{CL})		83.3		50.00				MHz
t _s	Input Setup Time		14		15		+ 2	+ 12		ns
t _H	Input Hold Time		0		0					ns
t _{CH}	Clock High Time	Clock Input	6		10					ns
t _{CL}	Clock Low Time	Clock Input	6		10					ns
t _{CO}	Clock to Output Delay	Clock Input		15		18			- 2	ns
t _{ARD}	CPLD Array Delay	Any Macrocell		11		16	+ 2			ns
t _{MIN}	Minimum Clock Period ²	t _{CH} +t _{CL}	12		20					ns

Note: 1. Fast Slew Rate output available on Port C and Port F.

2. CLKIN (PD1) t_{CLCL} = t_{CH} + t_{CL}.

Table 63. CPLD Macrocell Asynchronous Clock Mode Timing

Symbol	Parameter	Conditions	-70		-90		PT Aloc	Turbo Off	Slew Rate	Unit
			Min	Max	Min	Max				
f _{MAXA}	Maximum Frequency External Feedback	1/(t _{SA} +t _{COA})		38.4		26.32				MHz
	Maximum Frequency Internal Feedback (f _{CNTA})	1/(t _{SA} +t _{COA} -10)		62.5		35.71				MHz
	Maximum Frequency Pipelined Data	1/(t _{CHA} +t _{CLA})		47.6		37.03				MHz
t _{SA}	Input Setup Time		6		8		+ 2	+ 12		ns
t _{HA}	Input Hold Time		7		12					ns
t _{CHA}	Clock Input High Time		9		12			+ 12		ns
t _{CLA}	Clock Input Low Time		12		15			+ 12		ns
t _{COA}	Clock to Output Delay			21		30		+ 12	- 2	ns
t _{ARDA}	CPLD Array Delay	Any Macrocell		11		16	+ 2			ns
t _{MINA}	Minimum Clock Period	1/f _{CNTA}	16		28					ns

Figure 39. Input to Output Disable / Enable

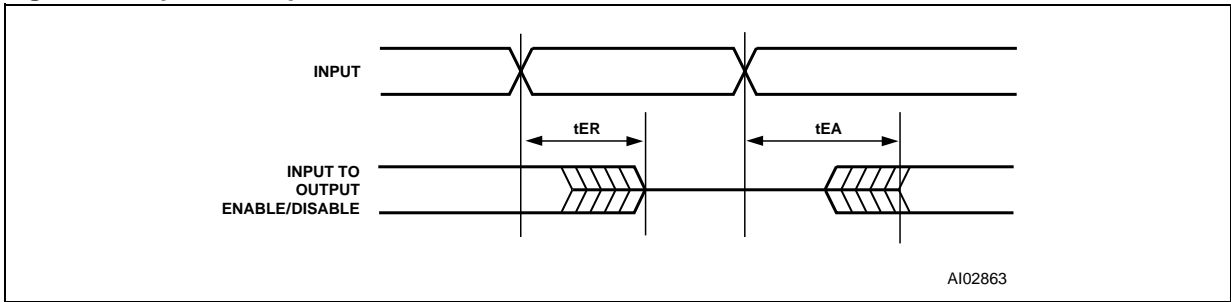

Figure 40. Asynchronous Reset / Preset

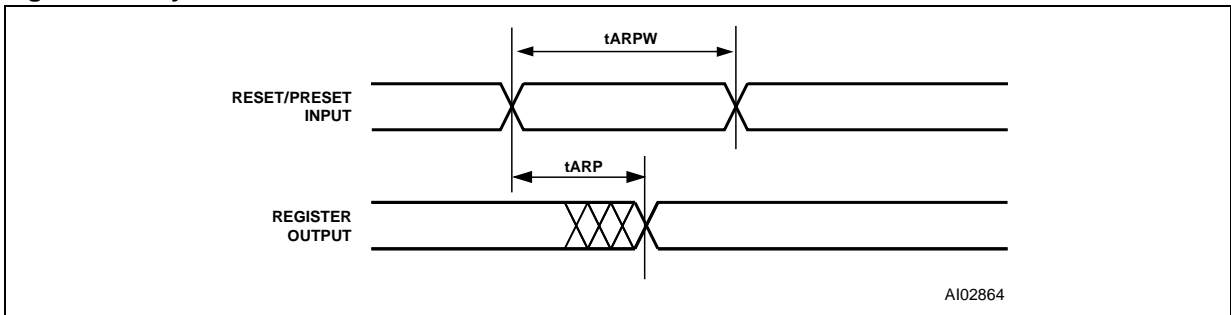

Figure 41. Synchronous Clock Mode Timing – PLD

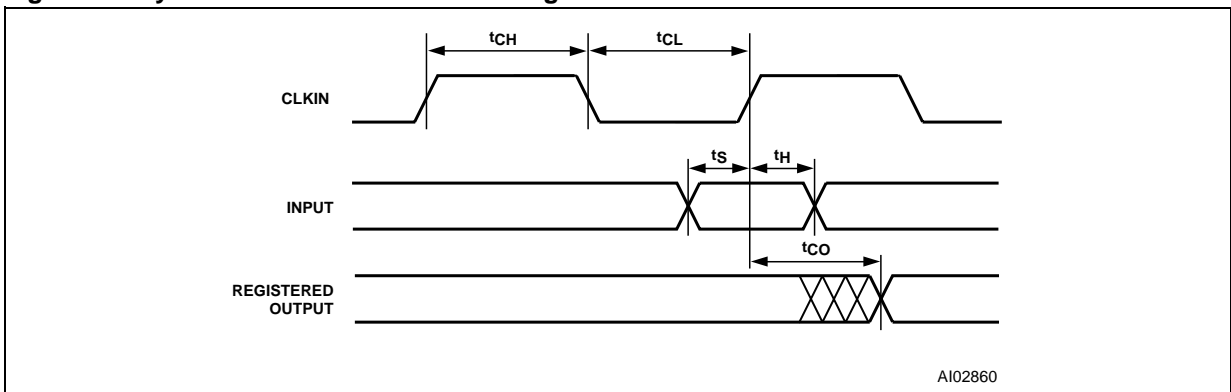

Figure 42. Asynchronous Clock Mode Timing (product term clock)

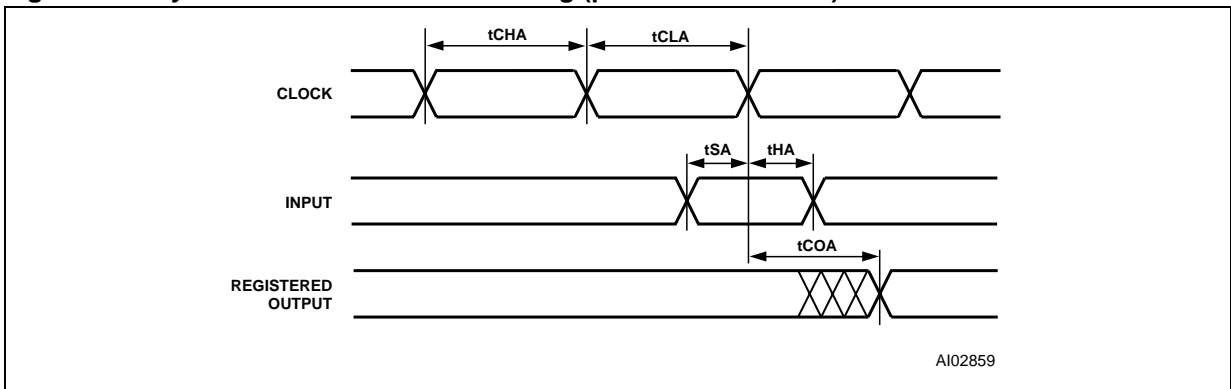

Table 64. Input Macrocell Timing

Symbol	Parameter	Conditions	-70		-90		PT Alloc	Turbo Off	Unit
			Min	Max	Min	Max			
t_{IS}	Input Setup Time	(Note 1)	0		0				ns
t_{IH}	Input Hold Time	(Note 1)	15		20		+ 12		ns
t_{INH}	NIB Input High Time	(Note 1)	9		12				ns
t_{INL}	NIB Input Low Time	(Note 1)	9		12				ns
t_{INO}	NIB Input to Combinatorial Delay	(Note 1)		34		46	+ 2	+ 12	ns

Note: 1. Inputs from Port A, B, and C relative to register/latch clock from the PLD. ALE latch timings refer to t_{AVLX} and t_{LXAX} .

Figure 43. Input Macrocell Timing (product term clock)

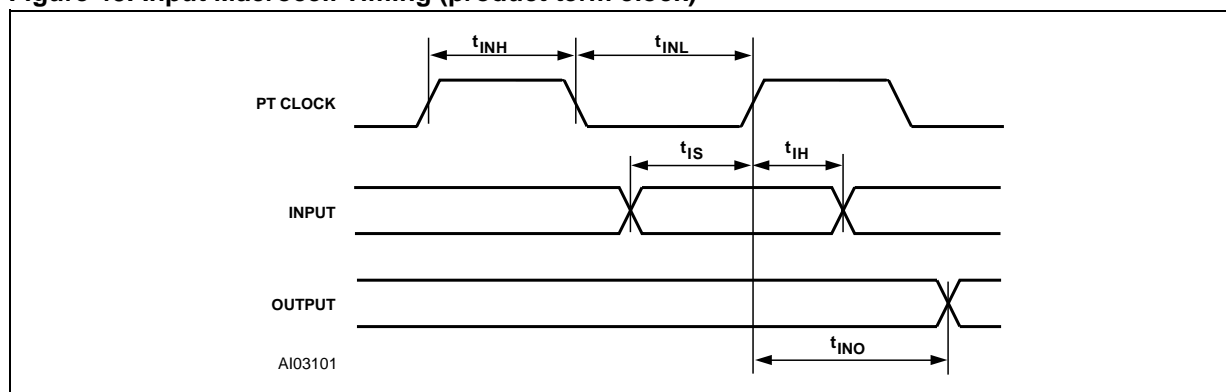

Table 65. Read Timing

Symbol	Parameter	Conditions	-70		-90		Turbo Off	Unit
			Min	Max	Min	Max		
t _{LVLX}	ALE or AS Pulse Width		15		20			ns
t _{AVLX}	Address Setup Time	(Note ³)	4		6			ns
t _{LXAX}	Address Hold Time	(Note ³)	7		8			ns
t _{AVQV}	Address Valid to Data Valid	(Note ³)		70		90	+ 12	ns
t _{SLQV}	CS Valid to Data Valid			75		100		ns
t _{RLQV}	\overline{RD} to Data Valid 8-Bit Bus	(Note ⁵)		24		32		ns
	\overline{RD} or \overline{PSEN} to Data Valid 8-Bit Bus, 8031, 80251	(Note ²)		31		38		ns
t _{RHQX}	\overline{RD} Data Hold Time	(Note ¹)	0		0			ns
t _{RLRH}	\overline{RD} Pulse Width	(Note ¹)	27		32			ns
t _{RHQZ}	\overline{RD} to Data High-Z	(Note ¹)		20		25		ns
t _{EHEL}	E Pulse Width		27		32			ns
t _{THEH}	R/ \overline{W} Setup Time to Enable		6		10			ns
t _{ELTL}	R/ \overline{W} Hold Time After Enable		0		0			ns
t _{AVPV}	Address Input Valid to Address Output Delay	(Note ⁴)		20		25		ns

Note: 1. \overline{RD} timing has the same timing as \overline{DS} , \overline{LDS} , \overline{UDS} , and \overline{PSEN} signals.

2. \overline{RD} and \overline{PSEN} have the same timing.

3. Any input used to select an internal PSD function.

4. In multiplexed mode, latched addresses generated from ADIO delay to address output on any Port.

5. \overline{RD} timing has the same timing as \overline{DS} , \overline{LDS} , and \overline{UDS} signals.

Figure 44. Read Timing

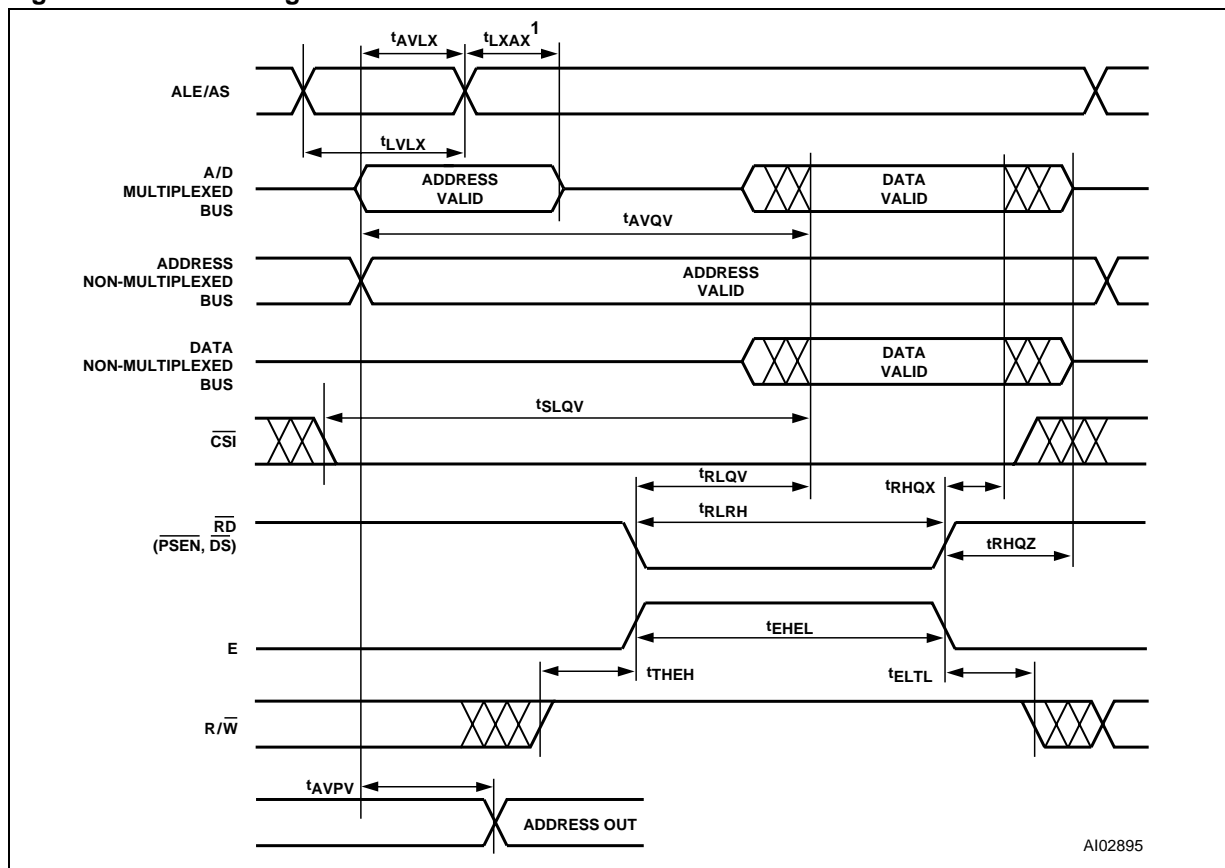

Note: 1. t_{AVLX} and t_{LXAX} are not required for 80C251 in Page Mode or 80C51XA in Burst Mode.

Table 66. Write Timing

Symbol	Parameter	Conditions	-70		-90		Unit
			Min	Max	Min	Max	
t _{LVLX}	ALE or AS Pulse Width		15		20		ns
t _{AVLX}	Address Setup Time	(Note ¹)	4		6		ns
t _{LXAX}	Address Hold Time	(Note ¹)	7		8		ns
t _{AVWL}	Address Valid to Leading Edge of \overline{WR}	(Notes ^{1,3})	8		15		ns
t _{SLWL}	\overline{CS} Valid to Leading Edge of \overline{WR}	(Note ³)	12		15		ns
t _{DVWH}	\overline{WR} Data Setup Time	(Note ³)	25		35		ns
t _{WHDX}	\overline{WR} Data Hold Time	(Note ^{3,7})	4		5		ns
t _{WLWH}	\overline{WR} Pulse Width	(Note ³)	28		35		ns
t _{WHAX1}	Trailing Edge of \overline{WR} to Address Invalid	(Note ³)	6		8		ns
t _{WHAX2}	Trailing Edge of \overline{WR} to DPLD Address Invalid	(Note ^{3,6})	0		0		ns
t _{WHPV}	Trailing Edge of \overline{WR} to Port Output Valid Using I/O Port Data Register	(Note ³)		27		30	ns
t _{DVMV}	Data Valid to Port Output Valid Using Macrocell Register Preset/Clear	(Notes ^{3,5})		42		55	ns
t _{AVPV}	Address Input Valid to Address Output Delay	(Note ²)		20		25	ns
t _{WLMV}	\overline{WR} Valid to Port Output Valid Using Macrocell Register Preset/Clear	(Notes ^{3,4})		48		55	ns

- Note: 1. Any input used to select an internal PSD function.
2. In multiplexed mode, latched address generated from ADIO delay to address output on any port.
3. \overline{WR} has the same timing as E, \overline{DS} , \overline{LDS} , \overline{UDS} , \overline{WRL} , and \overline{WRH} signals.
4. Assuming data is stable before active write signal.
5. Assuming write is active before data becomes valid.
6. t_{WHAX2} is the address hold time for DPLD inputs that are used to generate Sector Select signals for internal PSD memory.
7. t_{WHAX} is 6 ns when writing to the Output Macrocell Registers AB and BC.

Figure 45. Write Timing

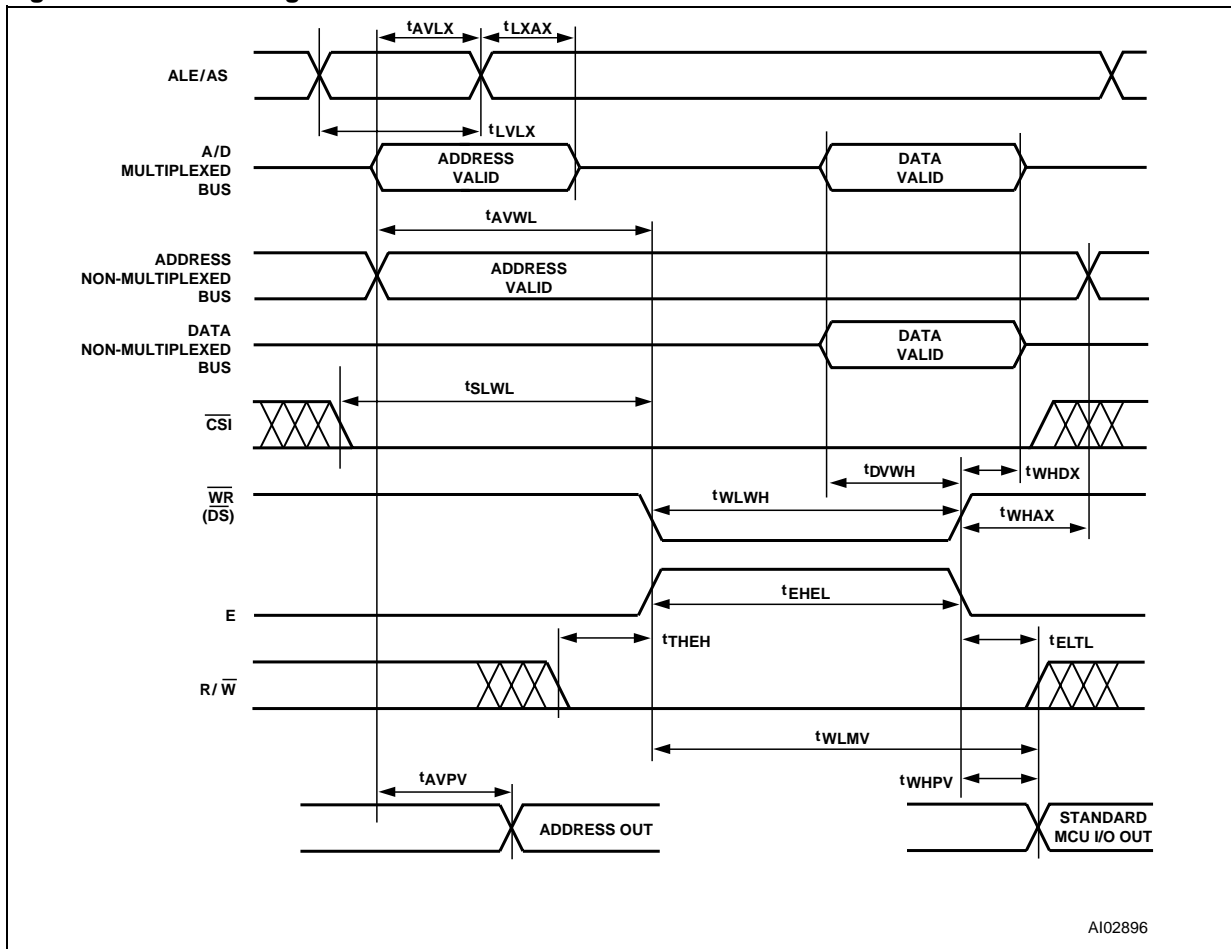
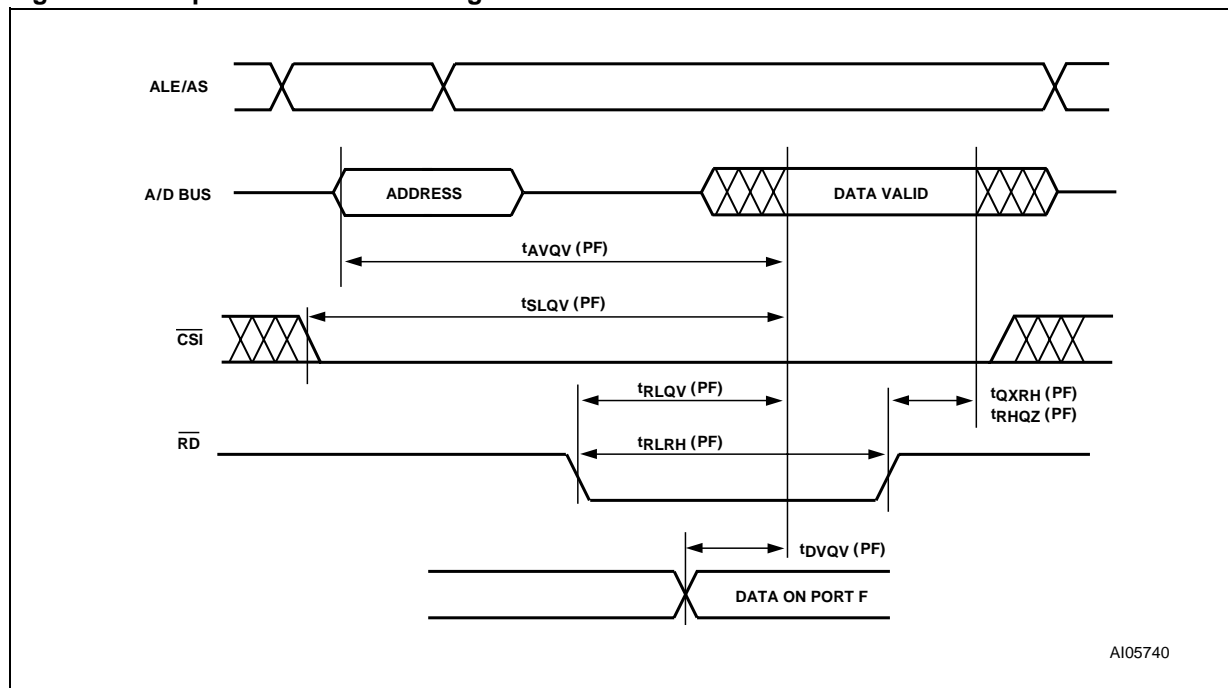

Table 67. Port F Peripheral Data Mode Read Timing

Symbol	Parameter	Conditions	-70		-90		Turbo Off	Unit
			Min	Max	Min	Max		
t _{AVQV-PF}	Address Valid to Data Valid	(Note ³)		30		35	+ 12	ns
t _{SLQV-PF}	\overline{CS} Valid to Data Valid			25		35	+ 12	ns
t _{RLQV-PF}	\overline{RD} to Data Valid	(Notes ^{1,4})		21		32		ns
	\overline{RD} to Data Valid 8031 Mode			31		38		ns
t _{DVQV-PF}	Data In to Data Out Valid			22		30		ns
t _{QXRH-PF}	\overline{RD} Data Hold Time		0		0			ns
t _{RLRH-PF}	\overline{RD} Pulse Width	(Note ¹)	27		32			ns
t _{RHQZ-PF}	\overline{RD} to Data High-Z	(Note ¹)		23		25		ns

Figure 46. Peripheral I/O Read Timing



AI05740

Table 68. Port F Peripheral Data Mode Write Timing

Symbol	Parameter	Conditions	-70		-90		Unit
			Min	Max	Min	Max	
t _{WLQV-PF}	\overline{WR} to Data Propagation Delay	(Note ²)		25		35	ns
t _{DVQV-PF}	Data to Port F Data Propagation Delay	(Note ⁵)		22		30	ns
t _{WHQZ-PF}	\overline{WR} Invalid to Port F Tri-state	(Note ²)		20		25	ns

Note: 1. \overline{RD} has the same timing as \overline{DS} , \overline{LDS} , \overline{UDS} , and \overline{PSEN} (in 8031 combined mode).
 2. \overline{WR} has the same timing as the E, \overline{LDS} , \overline{UDS} , \overline{WRL} , and \overline{WRH} signals.
 3. Any input used to select Port F Data Peripheral mode.
 4. Data is already stable on Port F.
 5. Data stable on ADIO pins to data on Port F.

Figure 47. Peripheral I/O Write Timing

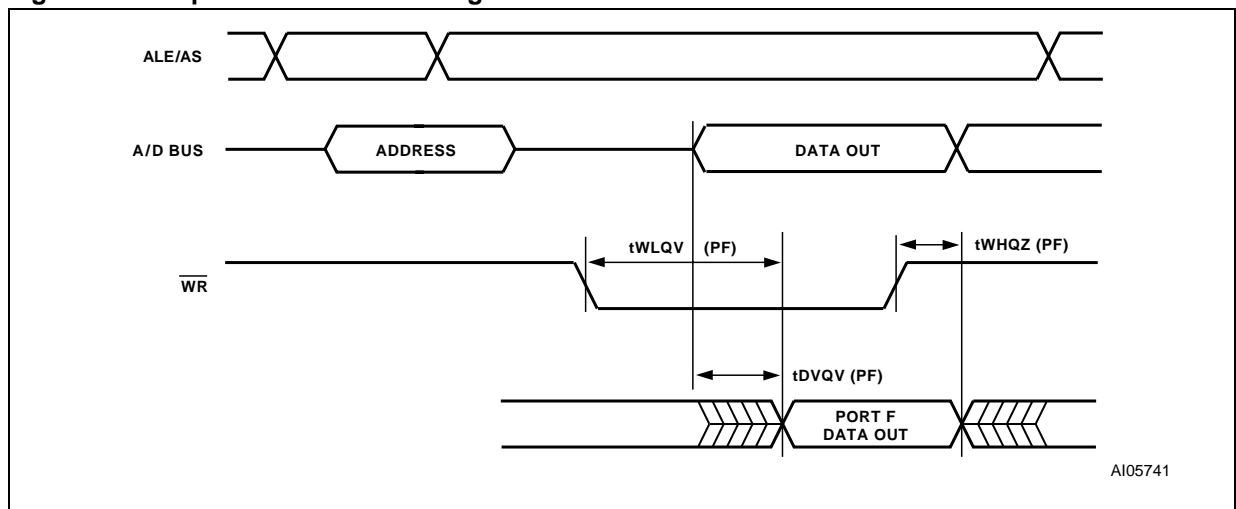

Table 69. Reset ($\overline{\text{RESET}}$) Timing

Symbol	Parameter	Conditions	Min	Max	Unit
t_{NLNH}	RESET Active Low Time ¹		150		ns
$t_{\text{NLNH-PO}}$	Power On Reset Active Low Time		1		ms
$t_{\text{NLNH-A}}$	Warm Reset ²		25		μs
t_{OPR}	RESET High to Operational Device			120	ns

Note: 1. Reset ($\overline{\text{RESET}}$) does not reset Flash memory Program or Erase cycles.
 2. Warm reset aborts Flash memory Program or Erase cycles, and puts the device in Read mode.

Figure 48. Reset ($\overline{\text{RESET}}$) Timing

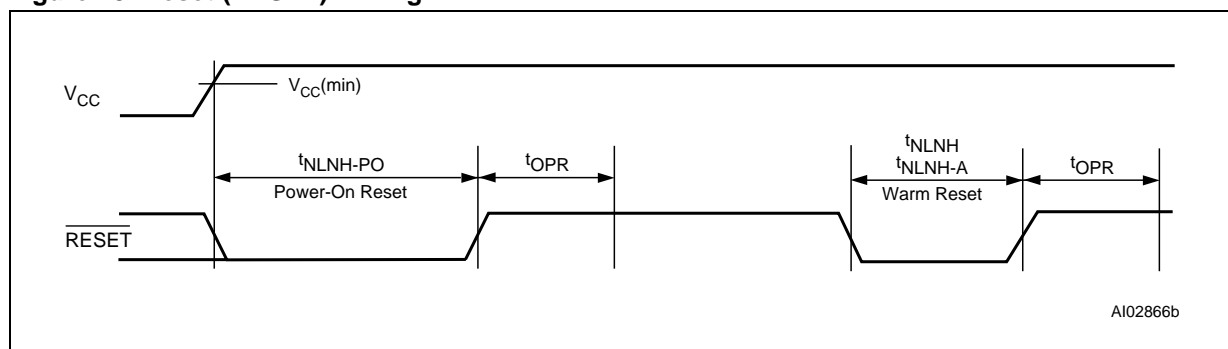

Table 70. V_{STBYON} Timing

Symbol	Parameter	Conditions	Min	Typ	Max	Unit
t_{BVBH}	V _{STBY} Detection to V _{STBYON} Output High	(Note ¹)		20		μs
t_{BXBL}	V _{STBY} Off Detection to V _{STBYON} Output Low	(Note ¹)		20		μs

Note: 1. V_{STBYON} timing is measured at V_{CC} ramp rate of 2 ms.

Table 71. Program, Write and Erase Times

Symbol	Parameter	Min.	Typ.	Max.	Unit
	Flash Program		8.5		s
	Flash Bulk Erase ¹ (pre-programmed)		3	30	s
	Flash Bulk Erase (not pre-programmed)		10		s
t_{WHQV3}	Sector Erase (pre-programmed)		1	30	s
t_{WHQV2}	Sector Erase (not pre-programmed)		2.2		s
t_{WHQV1}	Byte Program		14	1200	μs
	Program / Erase Cycles (per Sector)	100,000			cycles
t_{WHWLO}	Sector Erase Time-Out		100		μs
t_{Q7VQV}	DQ7 Valid to Output (DQ7-DQ0) Valid (Data Polling) ²			30	ns

Note: 1. Programmed to all zero before erase.
 2. The polling status, DQ7, is valid t_{Q7VQV} time units before the data byte, DQ0-DQ7, is valid for reading.
 3. DQ7 is DQ15 for Motorola MCU with 16-bit data bus.

Table 72. ISC Timing

Symbol	Parameter	Conditions	-70		-90		Unit
			Min	Max	Min	Max	
t_{ISCCF}	Clock (TCK, PC1) Frequency (except for PLD)	(Note 1)		20		18	MHz
t_{ISCHH}	Clock (TCK, PC1) High Time (except for PLD)	(Note 1)	23		26		ns
t_{ISCLL}	Clock (TCK, PC1) Low Time (except for PLD)	(Note 1)	23		26		ns
t_{ISCCFP}	Clock (TCK, PC1) Frequency (PLD only)	(Note 2)		2		2	MHz
t_{ISCHHP}	Clock (TCK, PC1) High Time (PLD only)	(Note 2)	240		240		ns
t_{ISCLLP}	Clock (TCK, PC1) Low Time (PLD only)	(Note 2)	240		240		ns
$t_{ISCPUSU}$	ISC Port Set Up Time		6		8		ns
t_{ISCPH}	ISC Port Hold Up Time		5		5		ns
t_{ISPCO}	ISC Port Clock to Output			21		23	ns
t_{ISCPZV}	ISC Port High-Impedance to Valid Output			21		23	ns
t_{ISCPVZ}	ISC Port Valid Output to High-Impedance			21		23	ns

Note: 1. For non-PLD Programming, Erase or in ISC by-pass mode.

2. For Program or Erase PLD only.

Figure 49. ISC Timing

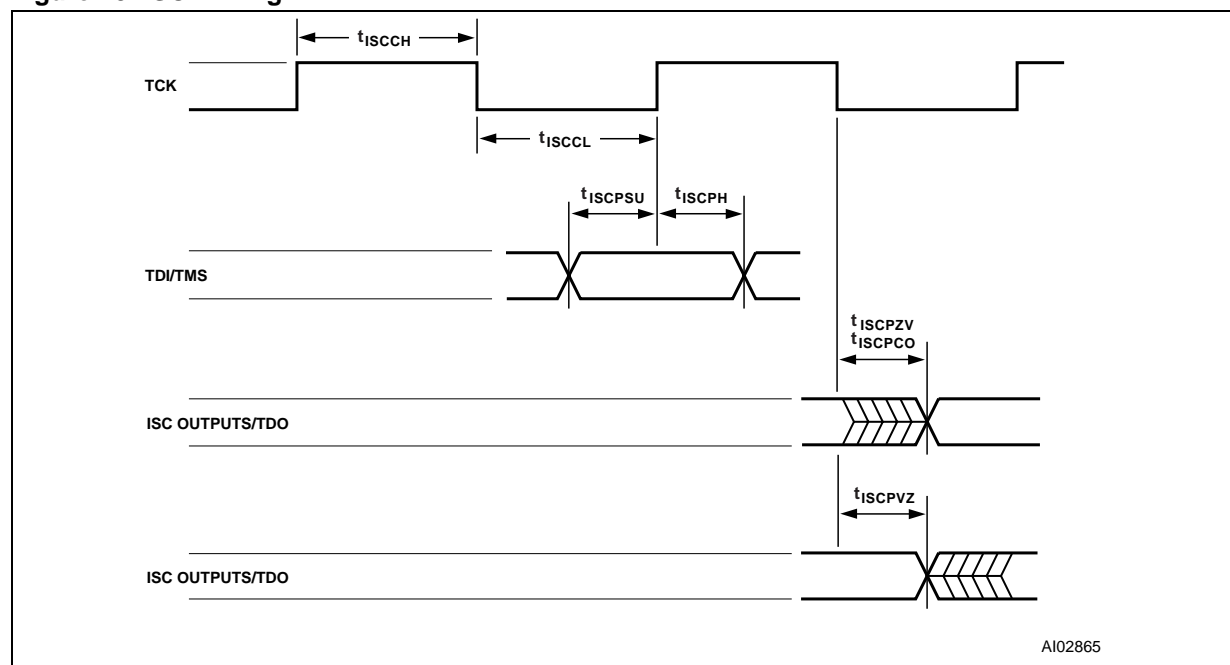

Table 73. Power-down Timing

Symbol	Parameter	Conditions	-70		-90		Unit
			Min	Max	Min	Max	
t _{LVDV}	ALE Access Time from Power-down			80		90	ns
t _{CLWH}	Maximum Delay from APD Enable to Internal PDN Valid Signal	Using CLKIN (PD1)	15 * t _{CLCL} ¹				μs

Note: 1. t_{CLCL} is the period of CLKIN (PD1).

PACKAGE MECHANICAL

TQFP80 - 80 lead Plastic Quad Flatpack

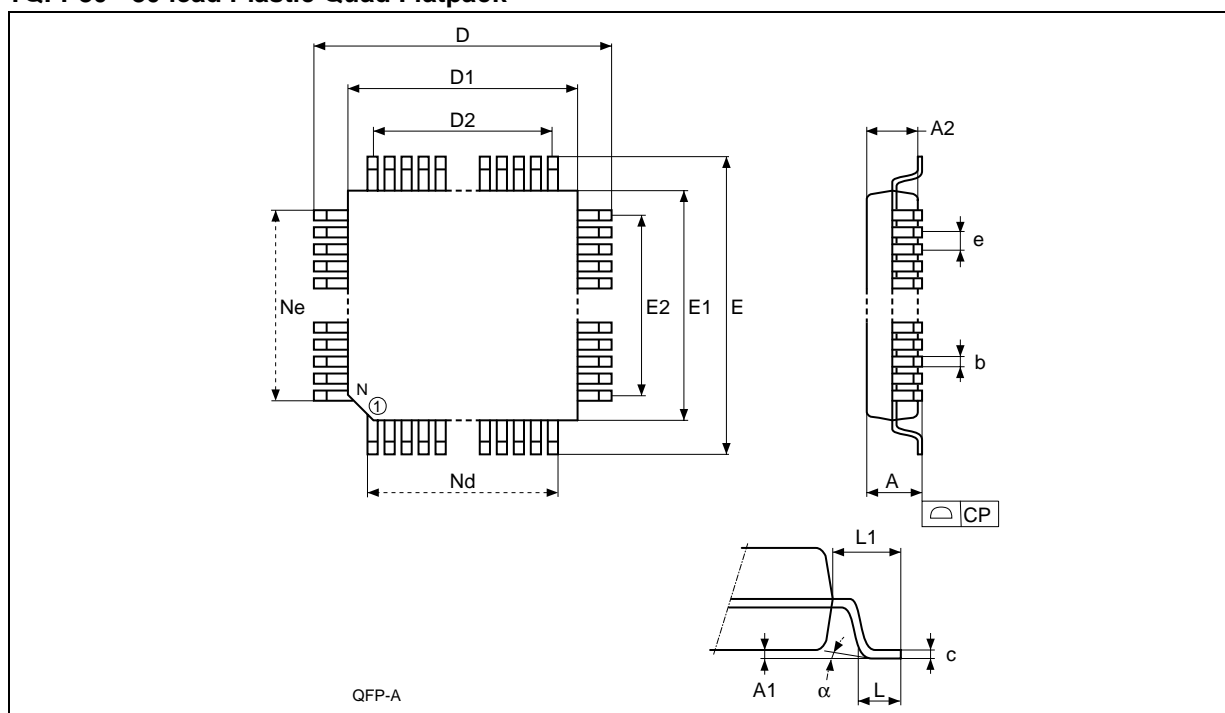

Note: Drawing is not to scale.

TQFP80 - 80 lead Plastic Quad Flatpack

Symb.	mm			inches		
	Typ.	Min.	Max.	Typ.	Min.	Max.
A			1.200			0.0472
A1		0.050	0.150		0.0020	0.0059
A2		0.950	1.050		0.0374	0.0413
α	3.5°	0.0°	7.0°	3.5°	0.0°	7.0°
b	0.220	0.170	0.270	0.0087	0.0067	0.0106
c		0.090	0.200		0.0035	0.0079
D	14.000			0.5512		
D1	12.000			0.4724		
D2	9.500	—	—	0.3740	—	—
E	14.000			0.5512		
E1	12.000			0.4724		
E2	9.500	—	—	0.3740	—	—
e	0.500	—	—	0.0197	—	—
L	0.600	0.450	0.750	0.0236	0.0177	0.0295
L1	1.000			0.0394		
CP	0.080			0.0031		
N		80			80	
Nd		20			20	
Ne		20			20	

Table 74. Pin Assignments – TQFP80

Pin No.	Pin Assignments	Pin No.	Pin Assignments	Pin No.	Pin Assignments	Pin No.	Pin Assignments
1	PD2	21	PG0	41	PC0	61	PB0
2	PD3	22	PG1	42	PC1	62	PB1
3	AD0	23	PG2	43	PC2	63	PB2
4	AD1	24	PG3	44	PC3	64	PB3
5	AD2	25	PG4	45	PC4	65	PB4
6	AD3	26	PG5	46	PC5	66	PB5
7	AD4	27	PG6	47	PC6	67	PB6
8	GND	28	PG7	48	PC7	68	PB7
9	V _{CC}	29	V _{CC}	49	GND	69	V _{CC}
10	AD5	30	GND	50	GND	70	GND
11	AD6	31	PF0	51	PA0	71	PE0
12	AD7	32	PF1	52	PA1	72	PE1
13	AD8	33	PF2	53	PA2	73	PE2
14	AD9	34	PF3	54	PA3	74	PE3
15	AD10	35	PF4	55	PA4	75	PE4
16	AD11	36	PF5	56	PA5	76	PE5
17	AD12	37	PF6	57	PA6	77	PE6
18	AD13	38	PF7	58	PA7	78	PE7
19	AD14	39	RESET	59	CNTL0	79	PD0
20	AD15	40	CNTL2	60	CNTL1	80	PD1

PART NUMBERING

Table 75. Ordering Information Scheme

Example:	PSD423	5	G	2	V	-	90	U	I	T
Device Type										
PSD42 = Flash PSD for 16-bit MCUs (with CPLD)										
SRAM Size										
0 = none	3 = 64 Kbit									
1 = 16 Kbit	4 = 128 Kbit									
2 = 32 Kbit	5 = 256 Kbit									
Flash Memory Size										
1 = 256 Kbit	4 = 2 Mbit									
2 = 512 Kbit	5 = 4 Mbit									
3 = 1 Mbit	6 = 8 Mbit									
I/O Count										
F = 27 I/O										
G = 52 I/O										
2nd Non Volatile Memory										
1 = 256 Kbit EEPROM										
2 = 256 Kbit Flash memory										
3 = none										
6 = 512 Kbit Flash memory										
Operating Voltage										
blank = $V_{CC} = 4.5$ to $5.5V$										
$V^1 = V_{CC} = 3.0$ to $3.6V$										
Speed										
70 = 70 ns	12 = 120 ns									
90 = 90 ns	15 = 150 ns									
	20 = 200 ns									
Package										
U = TQFP80										
Temperature Range										
blank = 0 to 70 °C (commercial)										
I = -40 to 85 °C (industrial)										
Option										
T = Tape & Reel Packing										

Note: 1. The $3.3V \pm 10\%$ devices are not covered by this data sheet, but by the PSD4235G2V data sheet.

For a list of available options (speed, package, etc.) or for further information on any aspect of this device, please contact your nearest ST Sales Office.

REVISION HISTORY

Table 76. Document Revision History

Date	Rev.	Description of Revision
01-May-2001	1.0	Initial release as a WSI document
01-Aug-2001	1.1	Timing parameters updated
12-Sep-2001	2.0	Document rewritten using the ST template
14-Dec-2001	2.1	Information on the 3.3V±10% range removed to a separate data sheet

Information furnished is believed to be accurate and reliable. However, STMicroelectronics assumes no responsibility for the consequences of use of such information nor for any infringement of patents or other rights of third parties which may result from its use. No license is granted by implication or otherwise under any patent or patent rights of STMicroelectronics. Specifications mentioned in this publication are subject to change without notice. This publication supersedes and replaces all information previously supplied. STMicroelectronics products are not authorized for use as critical components in life support devices or systems without express written approval of STMicroelectronics.

The ST logo is registered trademark of STMicroelectronics
All other names are the property of their respective owners

© 2001 STMicroelectronics - All Rights Reserved

STMicroelectronics group of companies Australia - Brazil - Canada - China - Finland - France - Germany - Hong Kong -
India - Israel - Italy - Japan - Malaysia - Malta - Morocco - Singapore - Spain - Sweden - Switzerland - United Kingdom - United States.

www.st.com