

# 1 A low-side gate driver with configurable asymmetric sink/source

Datasheet - production data



## Features

- Low-side MOSFET driver
- 1 A sink and 0.8 A source capability
- Complementary outputs for source and sink driving
- Ext. reference for input threshold
- Wide supply voltage range (10 V ÷ 18 V)
- Input and output pull-down resistors
- Short propagation delays
- Input and output UVLO
- Wide operating temperature range: -40 °C to 125 °C
- SOT23-6L package

## Applications

- SMPS
- Digital lighting
- Wireless battery chargers
- Digitally controlled MOSFETs

## Description

The PM8851 device is a high frequency single channel low-side MOSFET driver specifically designed to work with digital power conversion microcontrollers, such as the STMicroelectronics STLUX™ family of products.

The PM8851 has complementary output pins to differentiate sink and source driving with a current capability of respectively 1 A and 0.8 A.

The input levels of the driver are derived by the voltage present at the IN\_TH pin (between 2 V and 5.5 V). This pin is typically connected at the same voltage of the microcontroller supply voltage.

The PM8851 includes both input and output pull-down resistors.

UVLO circuitry for input and output stages is present preventing the IC from driving external MOSFET in unsafe condition.

**Table 1. Device summary**

Order code	Option	Package
PM8851D	Low input threshold	SOT23-6L

# 1 Block diagram

Figure 1. Block diagram

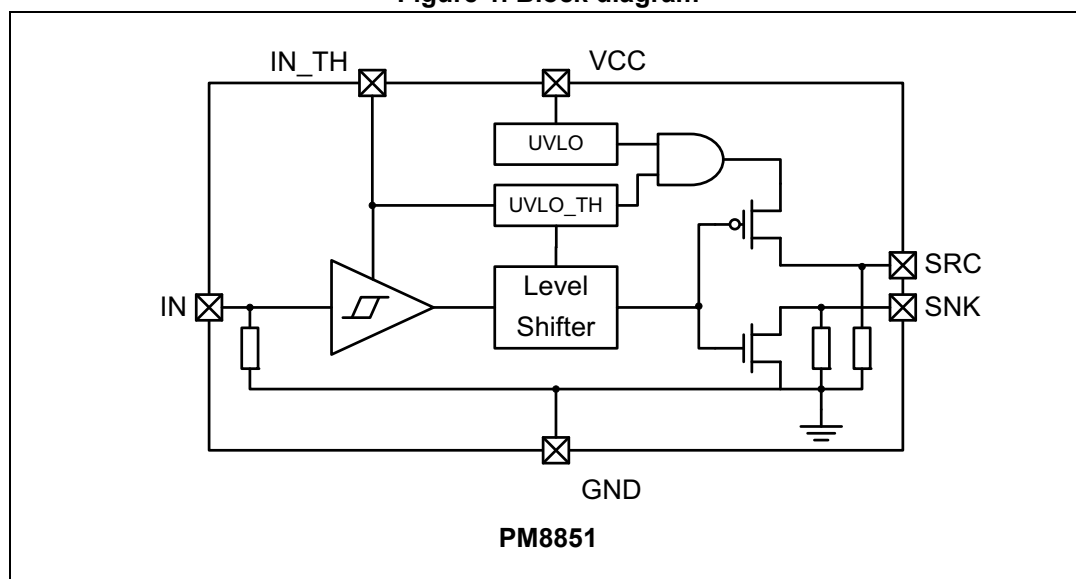

## 2 Pin connection

Figure 2. Pin connection

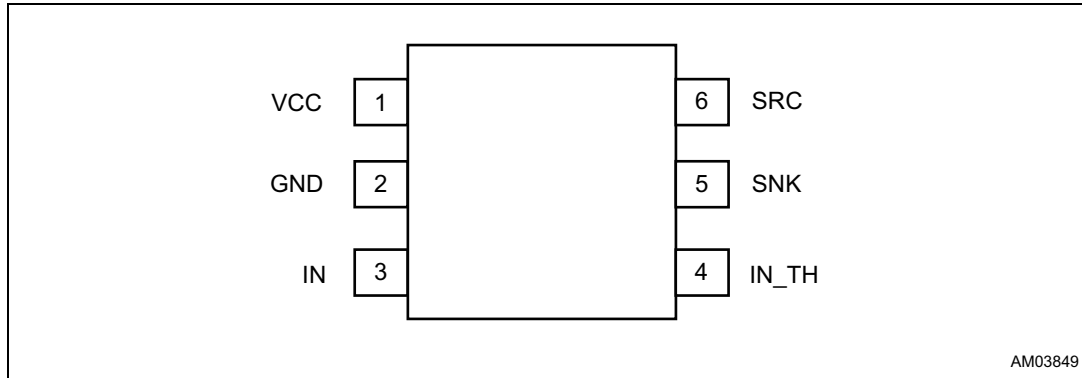

Table 2. Pinning

Symbol	Pin	Description
VCC	1	IC power supply. A voltage comprised between 10 V and 18 V can be connected between this pin and GND to supply the IC.
GND	2	Reference voltage connection.
IN	3	Digital input signal for driver. It is internally pulled down to GND with a 100 k $\Omega$ (typ.) equivalent resistor.
IN_TH	4	Input for IN pin's threshold definition: a voltage can be applied obtaining the values for VIH and VIL.
SNK	5	MOSFET gate drive sinking output controlled by the IN pin. A pull-down equivalent resistor [100 k $\Omega$ (typ.)] is present.
SRC	6	MOSFET gate drive sourcing output controlled by the IN pin. A pull-down equivalent resistor [100 k $\Omega$ (typ.)] is present.

### 3 Maximum ratings

**Table 3. Thermal data**

Symbol	Parameter	Value	Unit
$R_{thJA}$	Thermal resistance junction to ambient (2-layer FR4 PCB, $T_A = 27\text{ °C}$ natural convection)	250	°C/W
$R_{thJC}$	Thermal resistance junction to case	130	°C/W
$T_{MAX}$	Maximum junction temperature	150	°C
$T_{STG}$	Storage temperature range	-40 to 150	°C
$T_J$	Junction temperature range	-40 to 150	°C
$T_A$	Operating ambient temperature range	-40 to 125	°C

**Table 4. Absolute maximum ratings**

Symbol	Parameter	Value	Unit	Note
$V_{VCC,max}$	Maximum IC supply voltage	19	V	IN unconnected, IN_TH = 3.3 V
	Max. negative allowed voltage	- 0.3	V	
$V_{IN\_TH,max}$	Max. positive voltage at IN_TH pin	5.5	V	
	Max. negative allowed voltage	- 0.3	V	
$V_{IN,max}$	Maximum voltage at IN pin	5.5	V	
	Max. negative allowed voltage	- 0.3	V	
$I_{SRC,rms}$	Maximum RMS output current	40	mA	
$I_{SNK,rms}$	Maximum RMS output current	60	mA	

## 4 Electrical characteristics

( $V_{CC} = 12\text{ V}$ ,  $V_{IN\_TH} = 3.3\text{ V}$ ,  $T_J = -40 \div 125\text{ °C}$ , unless otherwise specified).

**Table 5. Electrical characteristics**

Symbol	Pin	Parameter	Test condition	Min.	Typ.	Max.	Unit
<b>IC SUPPLY</b>							
$V_{CC}$	VCC	Operating range		10		18	V
$V_{CC,on}$	VCC	Turn-on threshold		9	10	11	V
$V_{UVLO,hyst}$	VCC	UVLO hysteresis		0.5	1		V
$I_{ST-UP}$	VCC	Start-up current	$V_{CC} = V_{CC,on} - 0.5\text{ V}$			40	$\mu\text{A}$
$I_{CC,0}$	VCC	Static supply current	$I_N = 0\text{ V}$			40	$\mu\text{A}$
$I_{CC,op}$	VCC	Operating supply current	See <a href="#">Figure 4</a> and <a href="#">Figure 5</a>				
<b>IN_TH</b>							
$V_{IN\_TH}$	IN_TH	Operating range		2		5.5	V
$V_{IN\_TH,UV}$	IN_TH	IN_TH UVLO	IN_TH short with IN, rising edge		1.5		V
$I_{IN\_TH}$	IN_TH	IN_TH pin bias current <sup>(1)</sup>				40	$\mu\text{A}$
<b>INPUT</b>							
$V_{IH}/V_{IN\_TH}$	IN	Relative input high level threshold	<sup>(2)</sup>	36		58	%
$V_{IL}/V_{IN\_TH}$	IN	Relative input low level threshold	<sup>(2)</sup>	25		46	%
$V_{IN\_Hyst}$	IN	Hysteresis		7		25	%
$I_{IN}$	IN	IN pin bias current	$V_{IN} = 5\text{ V}$		50		$\mu\text{A}$
$R_{INPD}$	IN	Input pull-down resistance	$V_{IN} = V_{IN\_TH}$		100		$\text{k}\Omega$
$T_{D\_LH}$	IN	IN to GD propagation delay	IN low to high, no load			30	ns
$T_{D\_HL}$	IN	IN to GD propagation delay	IN high to low, no load			30	ns
<b>OUTPUT</b>							
$V_{SRC,H}$	SRC	SRC pin high level (when invoked by IN pin)	$I_{src} = 100\text{ mA}$ , $T_J = 25\text{ °C}$		11.4		V
			$I_{src} = 100\text{ mA}$ , $T_J = -40 \div 125\text{ °C}$ <sup>(1)</sup>		11.4		
$V_{SNK,L}$	SNK	SRC pin low level (when invoked by IN pin)	$I_{snk} = 100\text{ mA}$ , $T_J = 25\text{ °C}$		0.53		V
			$I_{snk} = 100\text{ mA}$ , $T_J = -40 \div 125\text{ °C}$ <sup>(1)</sup>		0.53		
$I_{SRC}$	SRC	Source current <sup>(1)</sup>	$V_{SRC} = V_{CC} / 2$		940		mA
$I_{SNK}$	SNK	Sink current <sup>(1)</sup>	$V_{SNK} = V_{CC} / 2$		1.1		A
$t_R$	SRC	Rise time	$C_{OUT} = 470\text{ pF}$			20	ns
$t_F$	SNK	Fall time	$C_{OUT} = 470\text{ pF}$			20	ns
$R_{GPD}$	SRC SNK	Pull-down resistor			100		$\text{k}\Omega$

1. Not tested in production.

2. Overlapping prevent by hysteresis  $V_{IN\_Hyst}$ .

Figure 3. Timings

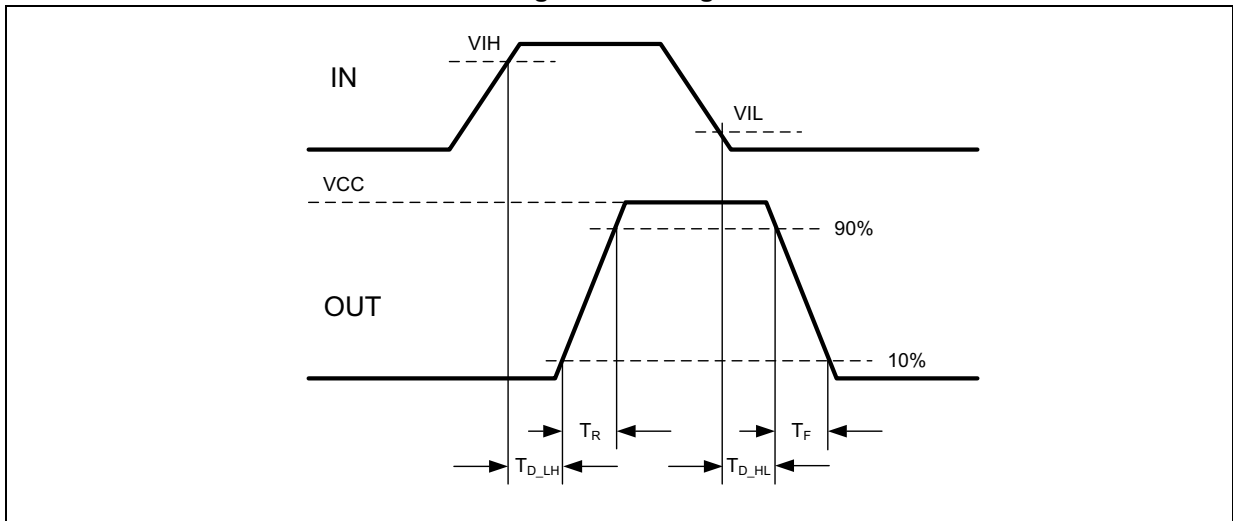

Figure 4. Operating supply current (no load)

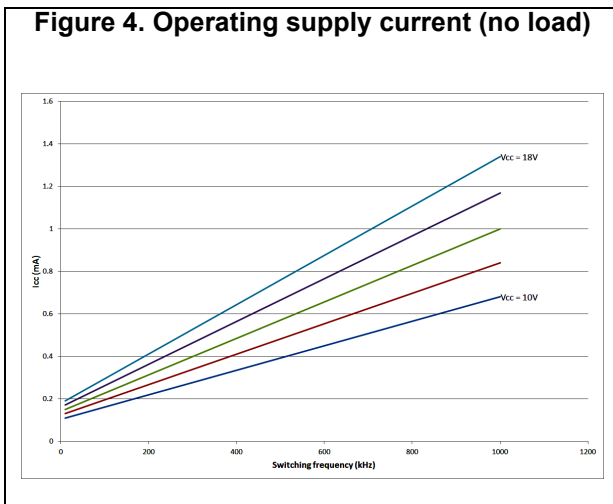

Figure 5. Operating supply current (C<sub>OUT</sub> = 470 pF)

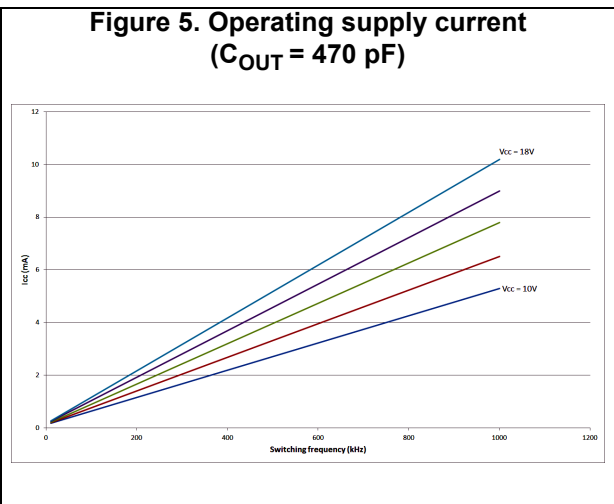
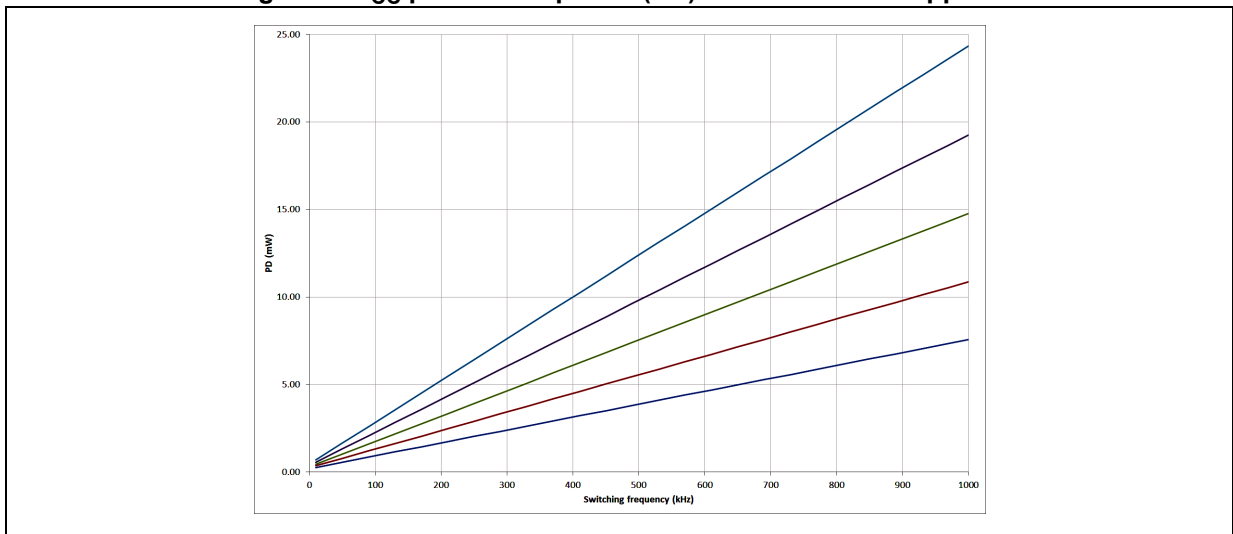

Figure 6. V<sub>CC</sub> power dissipation (PD) when no load is applied



# 5 Typical applications

Figure 7. Test circuit

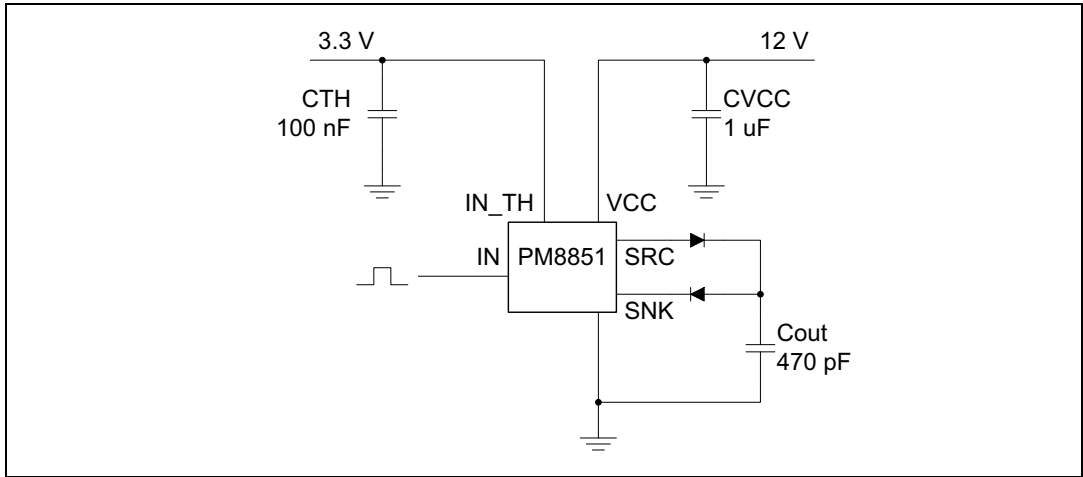

Figure 8. Digitally controlled PFC boost converter

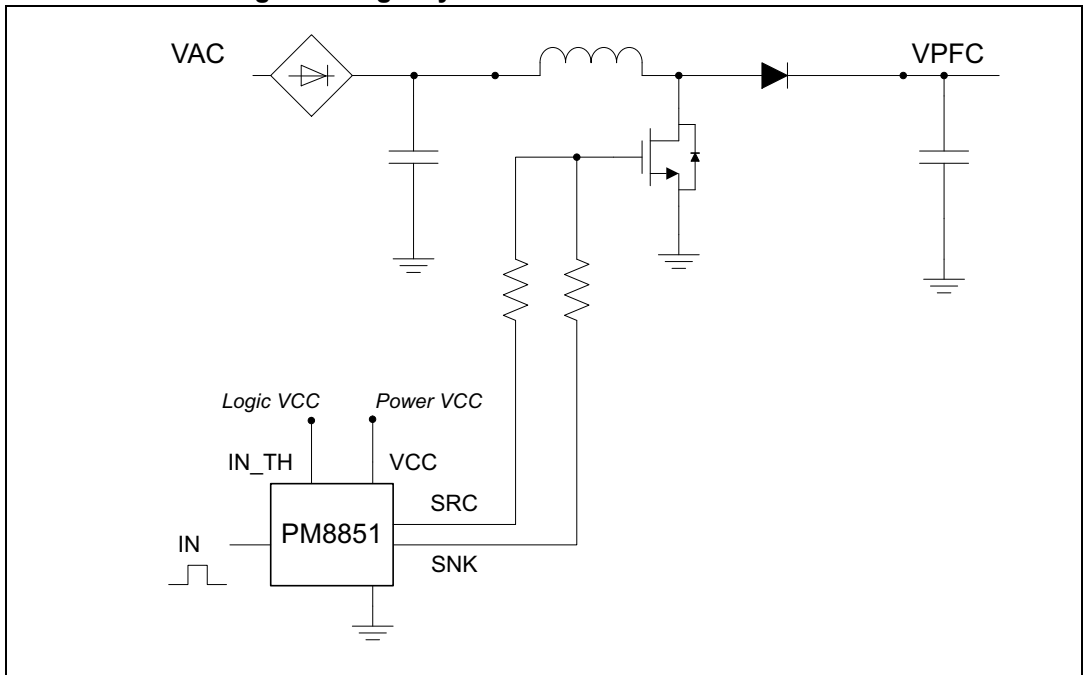

Figure 9. Digitally controlled flyback converter

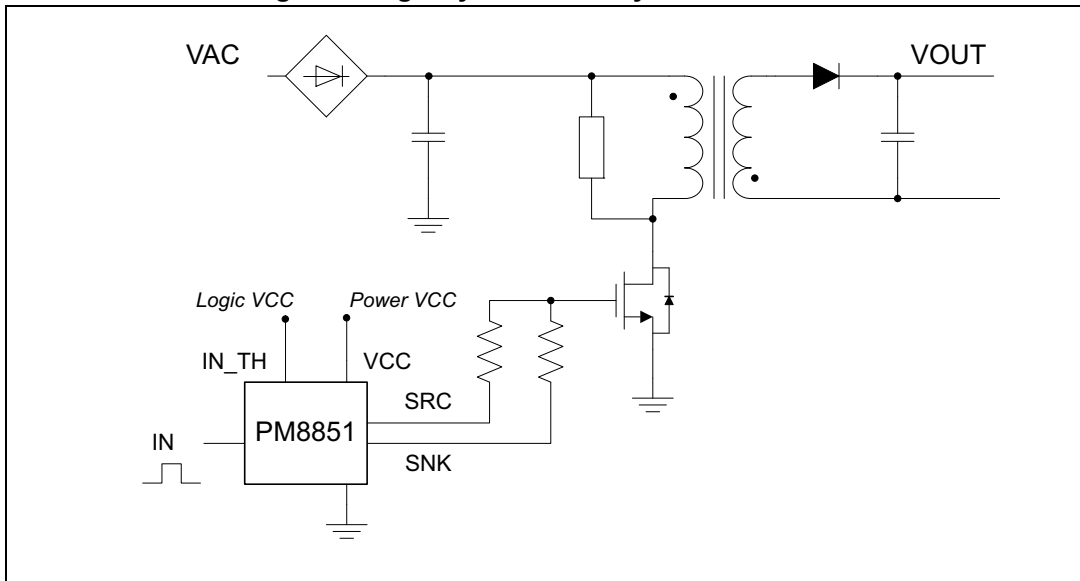
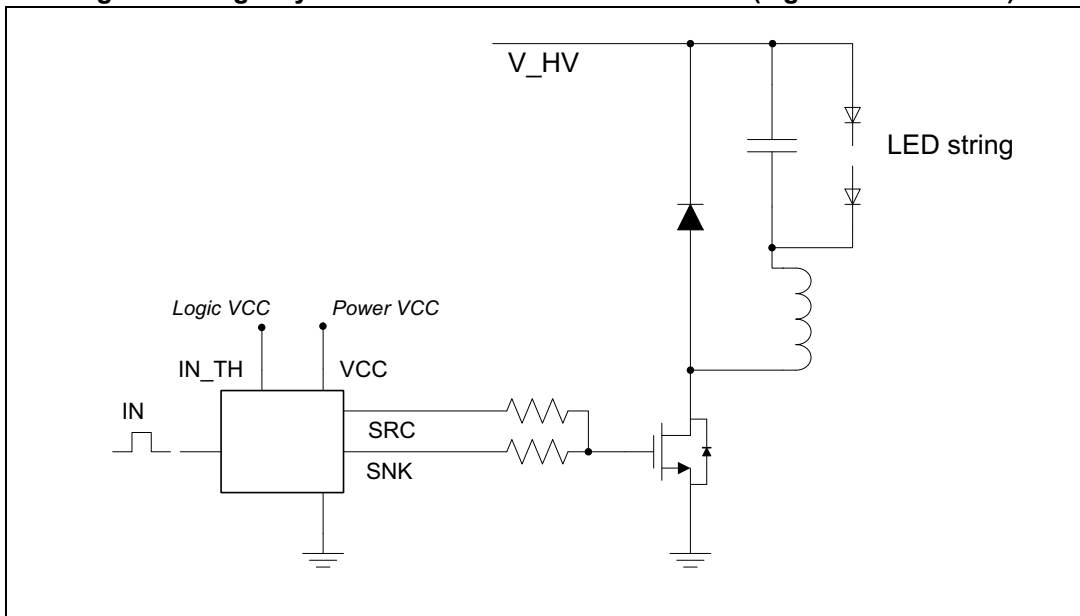

Figure 10. Digitally controlled inverse buck converter (e.g.: LED controller)





## 6 Application guidelines

### 6.1 Power supply

The PM8851 driver is intended to drive power MOSFETs used in power conversion topologies at high speed. The accurate supply voltage definition guarantees an effective driving in every condition. The voltage present at the IN\_TH pin is used for the threshold definition. It could be the same voltage used to supply the device providing the signal applied to the IN pin, or it can be derived by the VCC pin, eventually using a voltage divider. It is mainly suggested to provide IN\_TH voltage starting from VCC voltage.

For example, an auxiliary, unregulated voltage can be used to be connected to both PM8851 VCC pin and the input of a linear regulator that provides a well regulated supply voltage for logic circuitry. The same low voltage is then provided to the IN\_TH pin of the PM8851.

If the IN\_TH is derived directly by the VCC pin, the structure illustrated in [Figure 12](#) can be used.

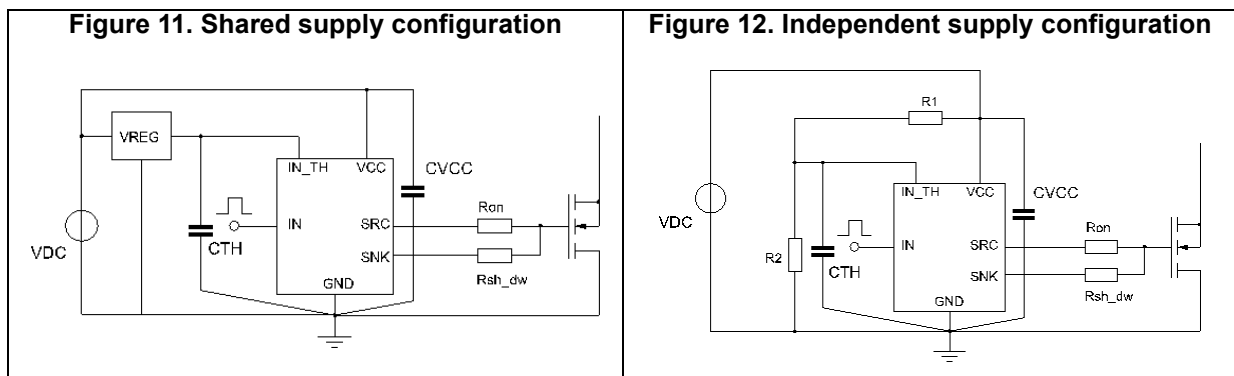

It is mandatory to properly connect a 100 nF ceramic cap as close as possible to the VCC pin to bypass the current's spikes absorbed by VCC during the gate charging.

Also IN\_TH voltage should be filtered with a ceramic capacitor (10 nF to 100 nF), especially when long traces are used to supply it; when derived by VCC a lighter filtering is allowed.

### 6.2 Layout suggestions

The small package of the PM8851 allows to place it very close to the gate of the driven MOSFET: this reduces the risk of injecting high frequency noise produced by the driving current running between the OUT pin and the MOSFET's gate pin.

## 6.3 Driving switches

The IN pin truth table is reported in [Table 6](#).

**Table 6. PM8851 truth table (levels refer to unloaded condition of SNK and SRC)**

IN	PM8851	
	SRC	SNK
High	Vcc	Hi-Z
Low	Hi-Z	GND

Differential MOSFET's driving strength is seldom necessary in topologies such as flybacks or boost controlled in the peak current mode. A lower driving current is used to turn-on the MOSFET in order to reduce the EMI produced by the Miller capacitance activation, while a stronger turn-off action is suggested to minimize the turn-off delay and, consequently the deviation between theoretical and practical behaviors.

The same asymmetrical driving strength is required when the IGBT switch is used: in fact the driving strength control is mandatory to avoid latch-up phenomena intrinsically related with this kind of the switch. The asymmetrical driving can be realized using different values for the resistances placed between the MOSFET's gate and the SRC and SNK pins.

When low switching frequencies are required and propagation delays can be compensated, it is possible to drive contemporary the IN pin and the IN\_TH pin to exploit the relevant UVLO threshold of the device (typ. 1.5 V) using the PM8851 as a fixed threshold device without any external component: care has to be taken to consider additional propagation delay (typ. 300 ns) after the falling edge of the input signal.

## 6.4 Power dissipation

Overall power dissipation can be evaluated considering two main contributions: the device related consumption (PD) and the gate driving power demand (PG):

### Equation 1

$$P_{Tot} = P_D + P_G$$

The device power consumption can be found in [Figure 6 on page 6](#), it represents the power required by the device to supply internal structures and pull-downs resistors.

The gate driving power dissipation is the power required to deliver to and from the MOSFET's gate the required gate charge:

### Equation 2

$$P_G = Q_g \times V_{gs} \times f_{sw}$$

The  $Q_g$  value can be found depicted into the MOSFET's datasheet for any applied  $V_{gs}$ :  $V_{gs}$  can be considered equal to VCC.

## 7 Package information

In order to meet environmental requirements, ST offers these devices in different grades of ECOPACK® packages, depending on their level of environmental compliance. ECOPACK specifications, grade definitions and product status are available at: [www.st.com](http://www.st.com). ECOPACK is an ST trademark.

Figure 13. SOT23-6L package outline

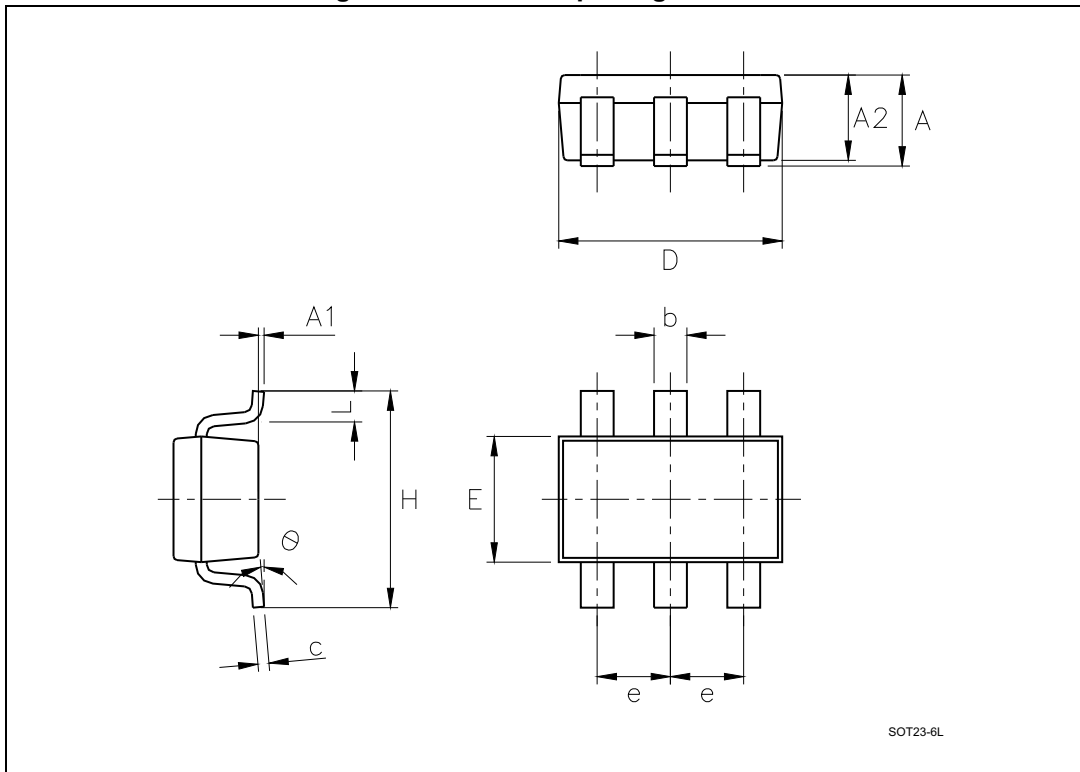

Table 7. SOT23-6L package mechanical data

Symbol	Dimensions <sup>(1)</sup>					
	mm			inch		
	Min.	Typ.	Max.	Min.	Typ.	Max.
A		0.9	1.45		0.035	0.057
A1		0	0.1		0	0.0039
A2		0.9	1.3		0.035	0.0512
b		0.35	0.5		0.014	0.02
c		0.09	0.2		0.004	0.008
D		2.8	3.05		0.11	0.120
E		1.5	1.75		0.059	0.0689
e	0.95			0.037		
H		2.6	3		0.102	0.118
L		0.1	0.6		0.004	0.024
$\theta$ (degrees)		0°	10°		0°	10°

1. Dimensions per JEDEC MO178AB.

## 8 Revision history

Table 8. Document revision history

Date	Revision	Changes
23-Oct-2014	1	Initial release.

**IMPORTANT NOTICE – PLEASE READ CAREFULLY**

STMicroelectronics NV and its subsidiaries ("ST") reserve the right to make changes, corrections, enhancements, modifications, and improvements to ST products and/or to this document at any time without notice. Purchasers should obtain the latest relevant information on ST products before placing orders. ST products are sold pursuant to ST's terms and conditions of sale in place at the time of order acknowledgement.

Purchasers are solely responsible for the choice, selection, and use of ST products and ST assumes no liability for application assistance or the design of Purchasers' products.

No license, express or implied, to any intellectual property right is granted by ST herein.

Resale of ST products with provisions different from the information set forth herein shall void any warranty granted by ST for such product.

ST and the ST logo are trademarks of ST. All other product or service names are the property of their respective owners.

Information in this document supersedes and replaces information previously supplied in any prior versions of this document.

© 2014 STMicroelectronics – All rights reserved