

RF power transistor, LDmoST plastic family

Features

- Excellent thermal stability
- Common source configuration
- Broadband performances:
 $P_{OUT} = 6\text{ W}$ with 13 dB gain @ 870 MHz
- Plastic package
- ESD protection
- Supplied in tape and reel
- In compliance with the 2002/95/EC european directive

Description

The PD84006L-E is a common source N-channel, enhancement-mode lateral Field-Effect RF power transistor. It is designed for high gain, broad band commercial and industrial applications. It operates at 7 V in common source mode at frequencies up to 1 GHz.

PD84006L-E's superior gain and efficiency makes it an ideal solution for portable radio and UHF RFID reader.

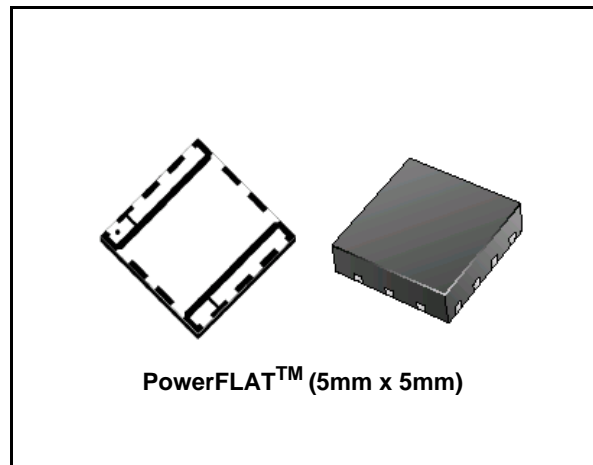

Figure 1. Pin connection

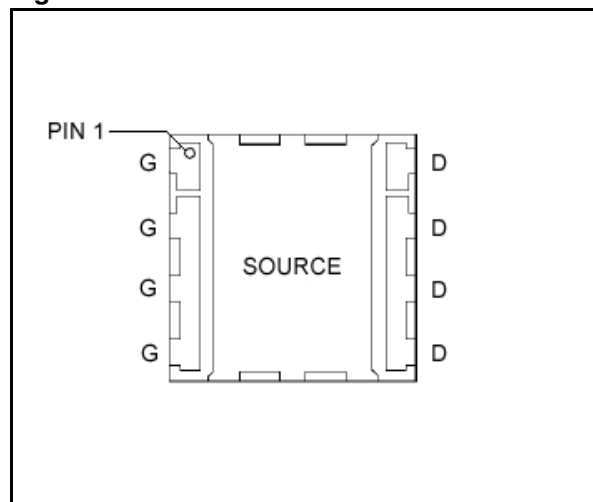

Table 1. Device summary

Order code	Marking	Package	Packaging
PD84006L-E	84006	PowerFLAT™ (5mm x 5mm)	Tape and reel

Contents

1	Electrical data	3
	1.1 Maximum ratings	3
	1.2 Thermal data	3
2	Electrical characteristics	4
	2.1 Static	4
	2.2 Dynamic	4
	2.3 ESD protection characteristics	4
	2.4 Moisture sensitivity level	4
3	Impedance	5
4	Typical performance	6
5	Test circuit	8
6	Circuit layout and photo	10
7	Package mechanical data	11
8	Revision history	15

1 Electrical data

1.1 Maximum ratings

Table 2. Absolute maximum ratings ($T_{CASE} = 25^{\circ}C$)

Symbol	Parameter	Value	Unit
$V_{(BR)DSS}$	Drain-source voltage	25	V
V_{GS}	Gate-source voltage	-0.5 to +15	V
I_D	Drain current	5	A
P_{DISS}	Power dissipation	31	W
T_J	Max. operating junction temperature	150	$^{\circ}C$
T_{STG}	Storage temperature	-65 to +150	$^{\circ}C$

1.2 Thermal data

Table 3. Thermal data

Symbol	Parameter	Value	Unit
R_{thJC}	Junction - case thermal resistance	4	$^{\circ}C/W$

2 Electrical characteristics

$$T_{CASE} = +25\text{ }^{\circ}\text{C}$$

2.1 Static

Table 4. Static

Symbol	Test conditions		Min	Typ	Max	Unit
I_{DSS}	$V_{GS} = 0\text{ V}$	$V_{DS} = 25\text{ V}$			1	μA
I_{GSS}	$V_{GS} = 5\text{ V}$	$V_{DS} = 0\text{ V}$			1	μA
$V_{GS(Q)}$	$V_{DS} = 10\text{ V}$	$I_D = 150\text{ mA}$		3.4		V
$V_{DS(ON)}$	$V_{GS} = 10\text{ V}$	$I_D = 1\text{ A}$		0.34		V
C_{ISS}	$V_{GS} = 0\text{ V}$	$V_{DS} = 7\text{ V}$		40		pF
C_{OSS}	$V_{GS} = 0\text{ V}$	$V_{DS} = 7\text{ V}$		33		pF
C_{RSS}	$V_{GS} = 0\text{ V}$	$V_{DS} = 7\text{ V}$		1.45		pF

2.2 Dynamic

Table 5. Dynamic

Symbol	Test conditions	Min	Typ	Max	Unit
P_{3dB}	$V_{DD} = 7.5\text{ V}$, $I_{DQ} = 150\text{ mA}$, $f = 870\text{ MHz}$	5	6		w
GPS	$V_{DD} = 7.5\text{ V}$, $I_{DQ} = 150\text{ mA}$, $P_{OUT} = 2\text{ W}$, $f = 870\text{ MHz}$	15			dB
nD	$V_{DD} = 7.5\text{ V}$, $I_{DQ} = 150\text{ mA}$, $P_{OUT} = P_{3dB}$, $f = 870\text{ MHz}$	50	60		%
Load mismatch	$V_{DD} = 9.5\text{ V}$, $I_{DQ} = 150\text{ mA}$, $P_{OUT} = 8\text{ W}$, $f = 870\text{ MHz}$ All phase angles	20:1			VSWR

2.3 ESD protection characteristics

Table 6. ESD protection characteristics

Test conditions	Class
Human body model	2
Machine model	M3

2.4 Moisture sensitivity level

Table 7. Moisture sensitivity level

Test methodology	Rating
J-STD-020B	MSL 3

3 Impedance

Figure 2. Current conventions

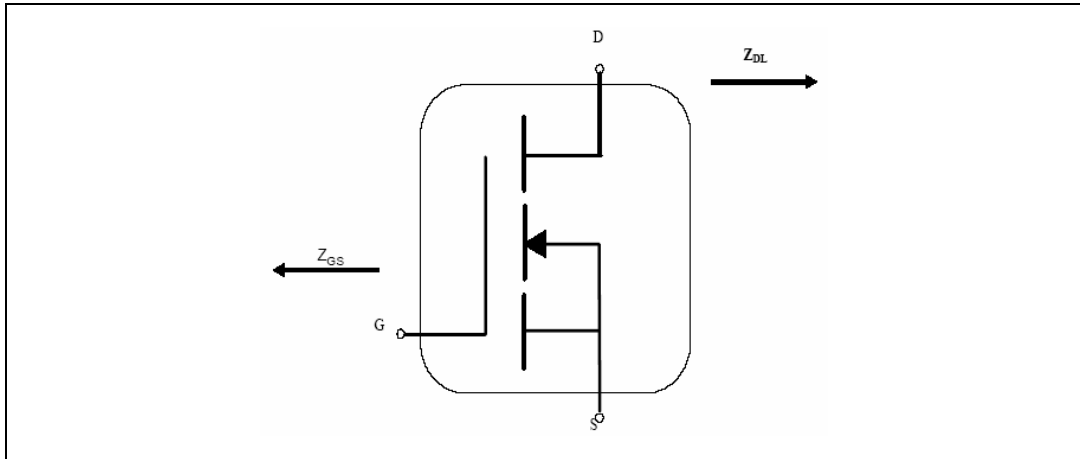

Table 8. Impedance data

Freq. (MHz)	Z _{IN} (Ω)	Z _{DL} (Ω)
740	2,52 + j1,42	3,06 + j0,41
750	2,52 + j1,56	3,09 + j0,51
760	2,51 + j1,73	3,12 + j0,64
770	2,46 + j1,84	3,13 + j0,72
780	2,47 + j1,96	3,13 + j0,81
790	2,48 + j2,07	3,13 + j0,87
800	2,45 + j2,22	3,14 + j0,96
810	2,44 + j2,27	3,08 + j1,02
820	2,45 + 2,43	3,05 + j1,04
830	2,41 + j2,57	3,04 + j1,11
840	2,40 + j2,67	2,98 + j1,14
850	2,41 + j2,80	2,99 + j1,24
860	2,38 + j2,92	2,91 + j1,29
870	2,37 + j3,06	2,88 + j1,38
880	2,36 + j3,20	2,81 + j1,40
890	2,37 + j3,25	2,70 + j1,47
900	2,31 + j3,36	2,56 + j1,53
910	2,25 + j3,49	2,50 + j1,62
920	2,16 + j3,57	2,31 + j1,72
930	2,16 + j3,66	2,21 + j1,82
940	2,11 + j3,78	2,11 + j1,96
950	2,06 + j3,86	1,98 + j2,07

4 Typical performance

Figure 3. Output power and efficiency vs frequency Vdd = 7.2 V, Idq = 200 mA
Pin = 24 dBm

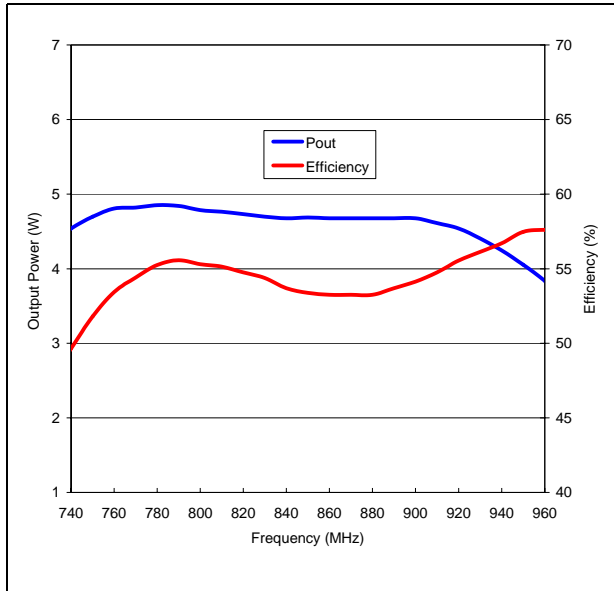

Figure 4. Gain vs output power Vdd = 7.2 V, Idq = 200 mA

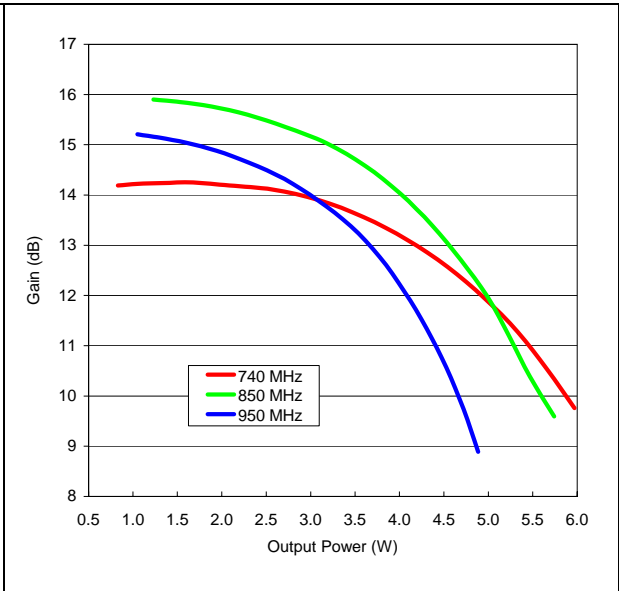

Figure 5. Input return loss vs frequency Vdd = 7.2 V, Idq = 200 mA

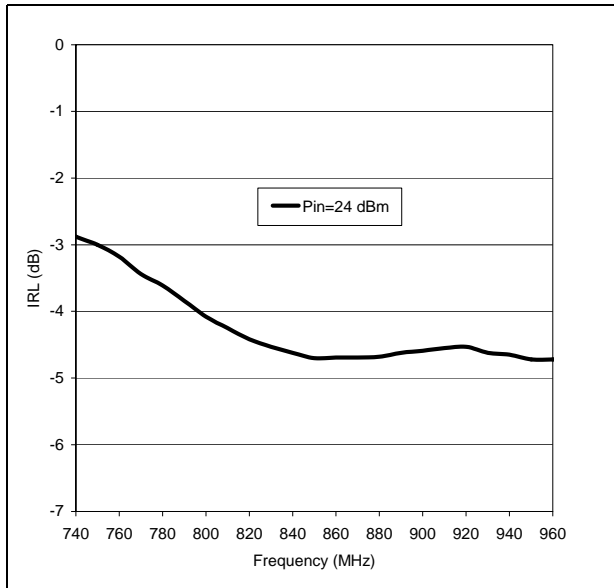

Figure 6. Harmonics vs frequency Vdd=7.2 V, Idq = 200 mA, Pin = 24 dBm

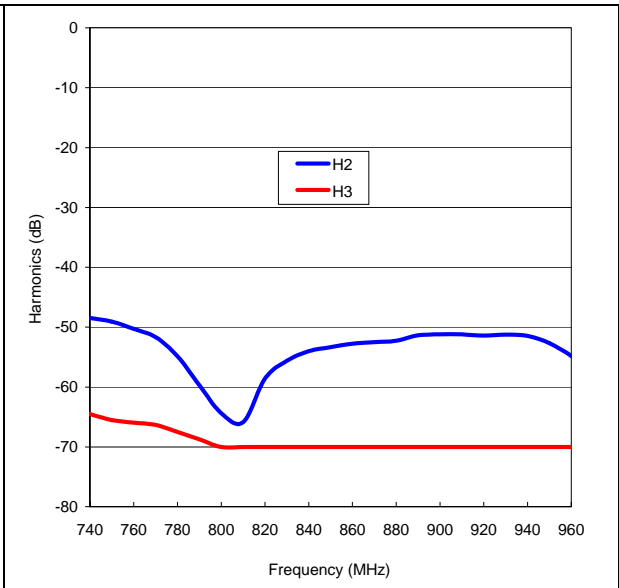
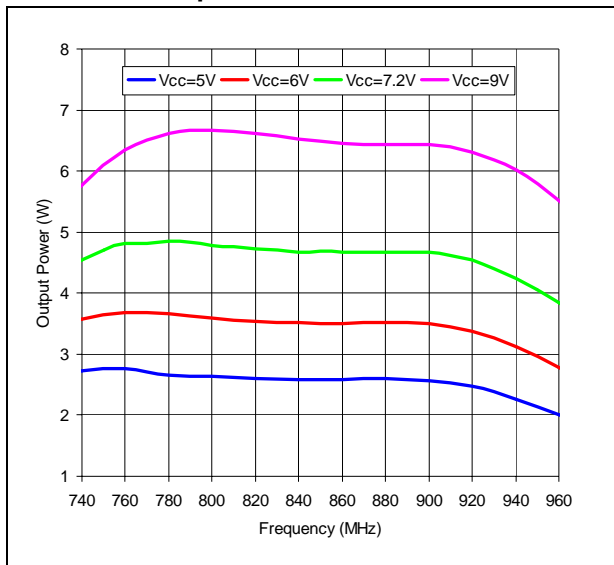

Figure 7. Output power vs frequency and supply voltage $P_{in} = 24 \text{ dBm}$, $I_{dq} = 200 \text{ mA}$



5 Test circuit

Figure 8. Test circuit schematic

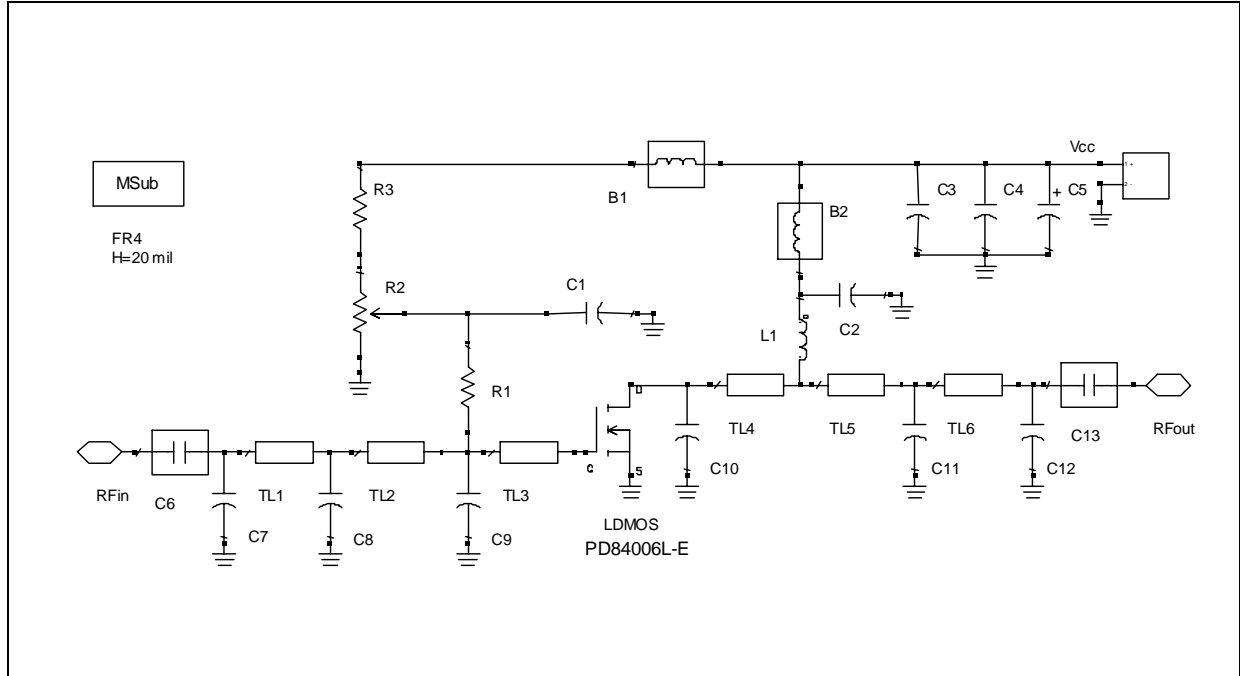

Table 9. Part list

Component ID	Description	Value	Case size	Manufacturer	Part code
B1, B2	Ferrite Bead			Panasonic	EXCELDRC35C
C1, C2	Capacitor	150 pF	0603	Murata	GRM39-C0G151J50D500
C3	Capacitor	1 nF	0603	Murata	GRM39-COG102J50D500
C4	Capacitor	10 nF	0603	Murata	GRM39-X7R103K50C560_
C5	Capacitor	10 uF	SMT	Panasonic	EEVHB1V100P
C6, C13	Capacitor	39 pF	0603	Murata	GRM39-C0G390J50D500
C7	Capacitor	3,3 pF	0603	Murata	GQM1885C2A3R3C
C8	Capacitor	8,2 pF	0603	Murata	GQM1885C1H8R2D
C9	Capacitor	18 pF	0603	Murata	GQM1885C1H180J
C10	Capacitor	15 pF	0603	Murata	GQM1885C1H150J
C11	Capacitor	12 pF	0603	Murata	GQM1885C1H120J
C12	Capacitor	4,7 pF	0603	Murata	GQM1885C2A4R7
L1	Inductor	12.55 nH		Coilcraft	1606-10

Table 9. Part list (continued)

Component ID	Description	Value	Case size	Manufacturer	Part code
R1	Resistor	56 Ω	0603	Tyco electronics	
R2	Potentiometer	10 K Ω		Bourns electronics	3214W-1-103E
R3	Resistor	1 K	0603	Tyco electronics	01623440-1
TL1	Transmission line	W=0.92mm	L= 13,50 mm		
TL2	Transmission line	W=0.92mm	L= 3,15 mm		
TL3	Transmission line	W=0.92mm	L= 2,90 mm		
TL4	Transmission line	W=0.92mm	L= 2,00 mm		
TL5	Transmission line	W=0.92mm	L= 2,20 mm		
TL6	Transmission line	W=0.92mm	L= 13,20 mm		
RF in, RF out	SMA-CONN	50 Ω	60 mils	JOHNSON	142-0701-801
PD84006L-E	LDMOS			STMicroelectronics	PD84006L-E
Board	FR-4 THk=0.020" 2OZ Cu both sides				

6 Circuit layout and photo

Figure 9. Circuit layout

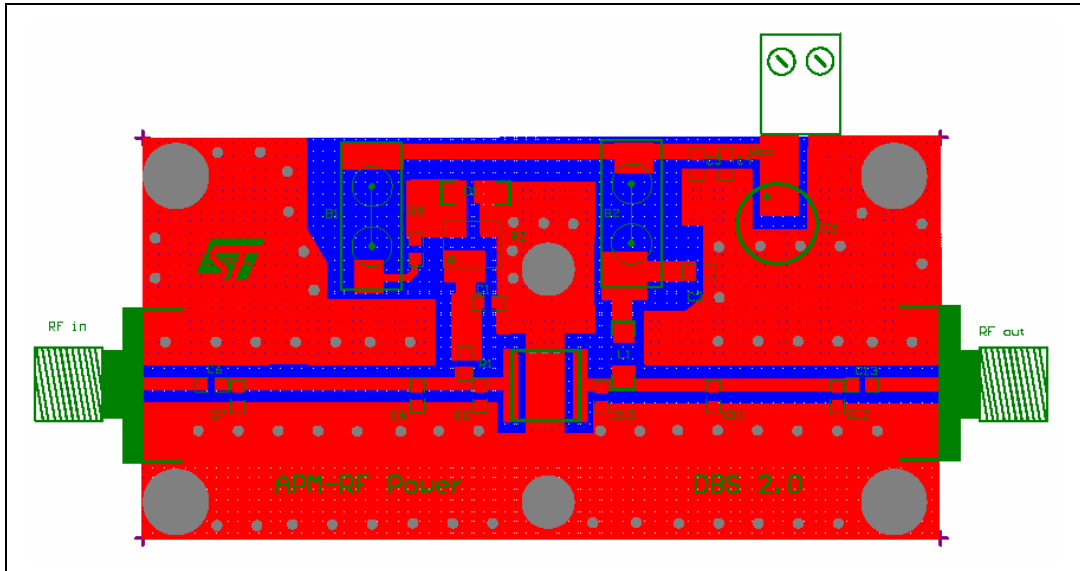
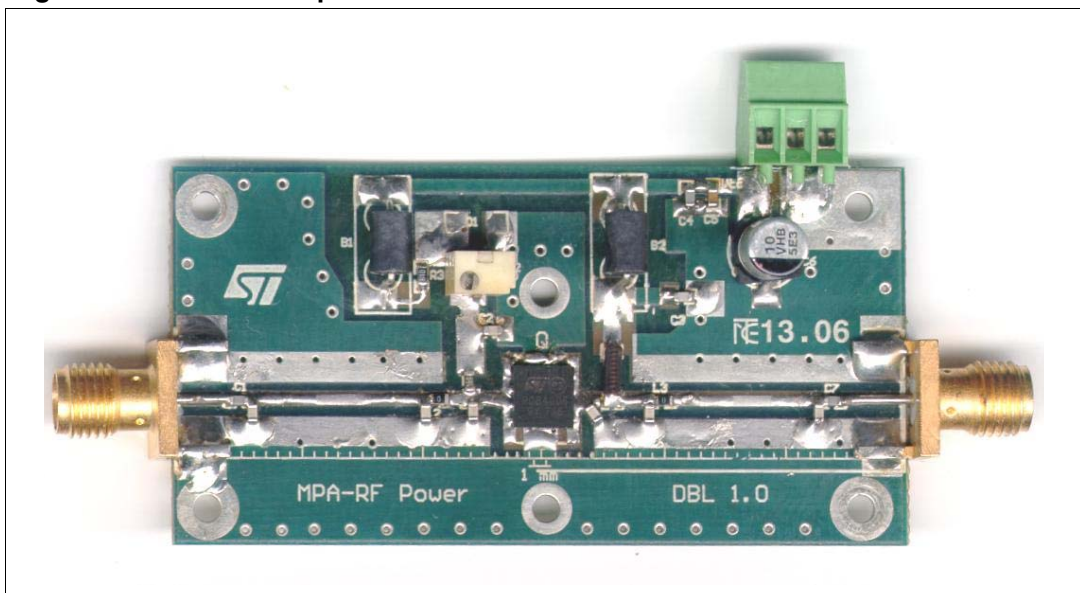

Figure 10. Demoboard photo



7 Package mechanical data

In order to meet environmental requirements, ST offers these devices in ECOPACK® packages. These packages have a Lead-free second level interconnect . The category of second level interconnect is marked on the package and on the inner box label, in compliance with JEDEC Standard JESD97. The maximum ratings related to soldering conditions are also marked on the inner box label. ECOPACK is an ST trademark. ECOPACK specifications are available at: www.st.com

Table 10. Tape and reel dimensions

Dim.	Mm		
	Min.	Typ	Max.
Ao	5.15	5.25	5.35
Bo	5.15	5.25	5.35
Ko	1.0	1.1	1.2

Figure 11. Tape and reel dimensions

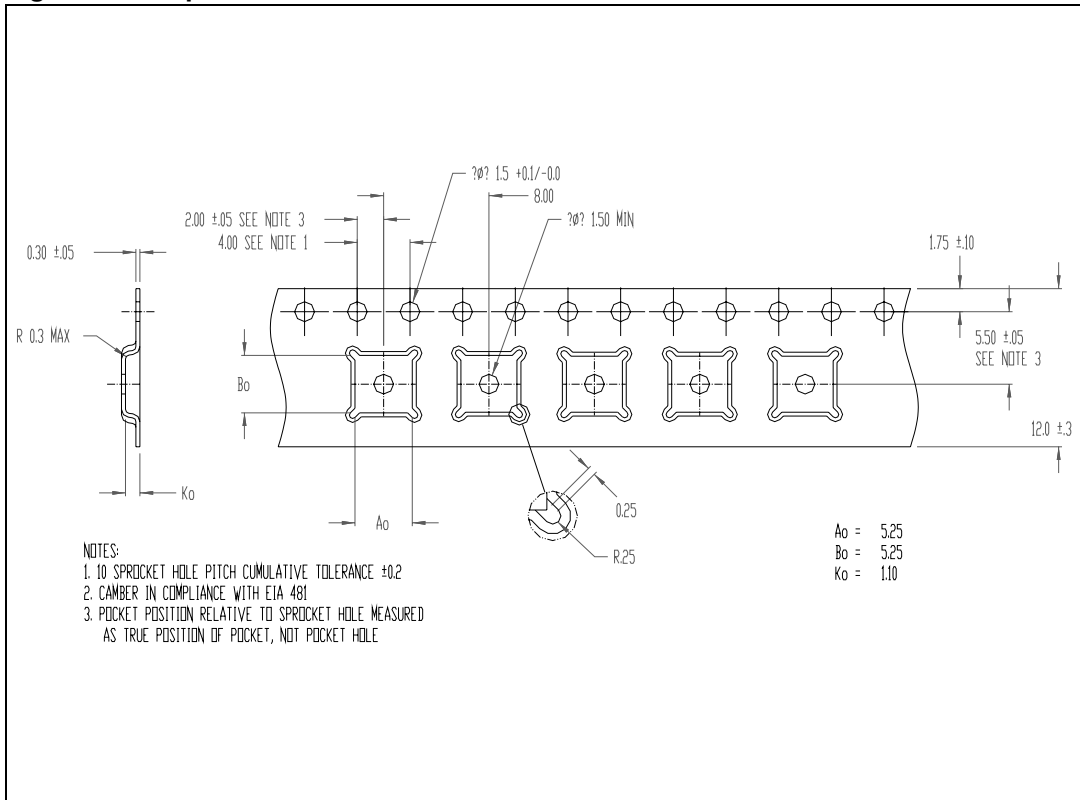

Figure 12. PowerFLAT™ (5x5) recommended footprint

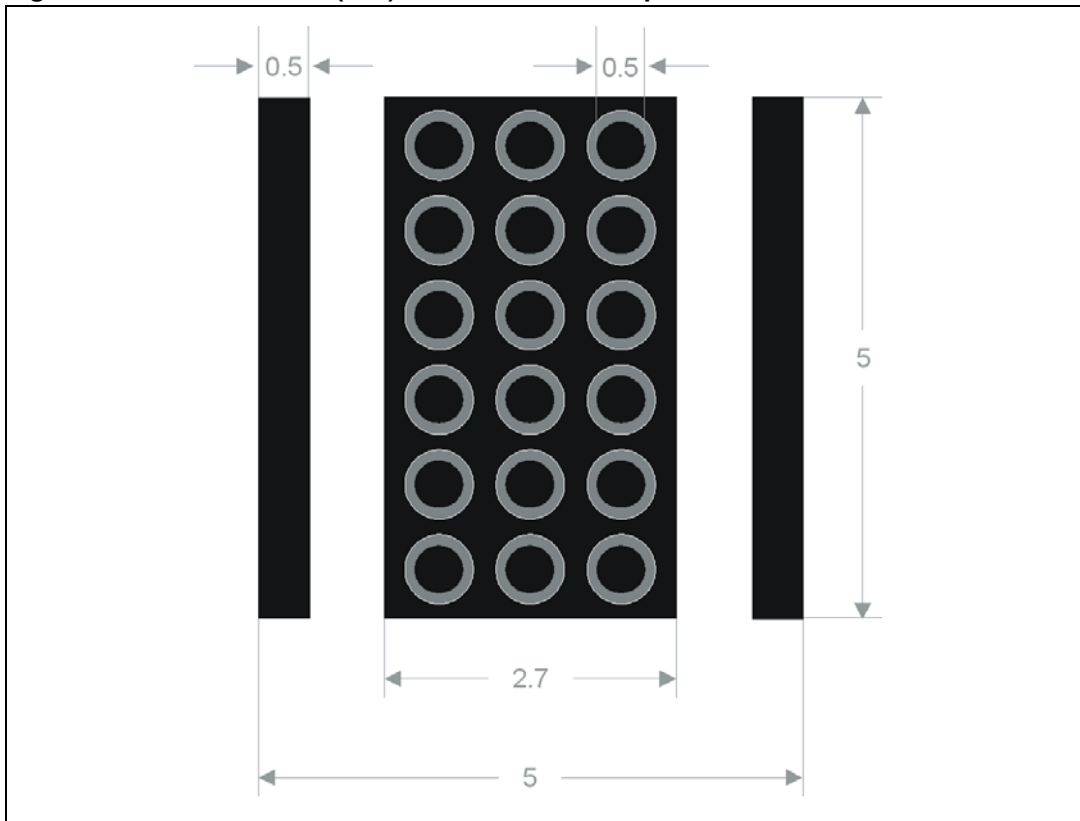
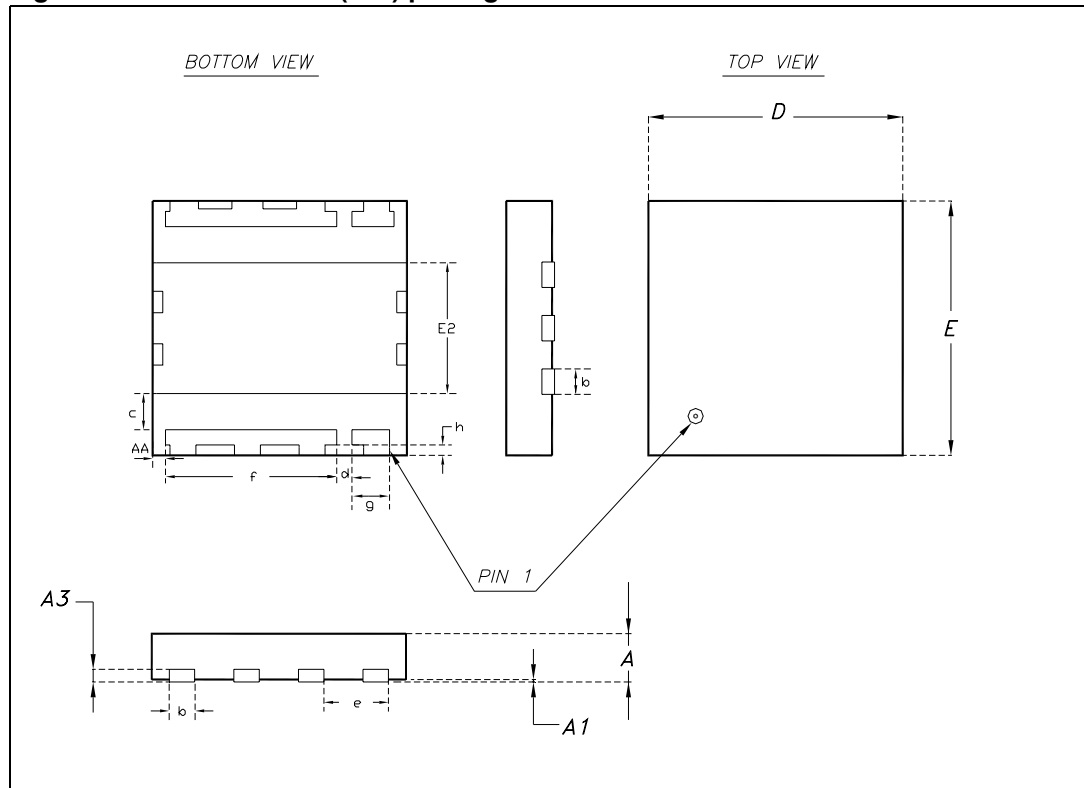

Table 11. PowerFLAT™ (5x5) mechanical data

Dim.	mm			inch		
	Min	Typ	Max	Min	Typ	Max
A		0.90	1.00		0.035	0.039
A1		0.02	0.05		0.001	0.002
A3		0.24			0.009	
AA	0.15	0.25	0.35	0.006	0.01	0.014
b	0.43	0.51	0.58	0.017	0.020	0.023
c	0.64	0.71	0.79	0.025	0.028	0.031
D		5.00			0.197	
d		0.30			0.011	
E		5.00			0.197	
E2	2.49	2.57	2.64	0.098	0.101	0.104
e		1.27			0.050	
f		3.37			0.132	
g		0.74			0.03	
h		0.21			0.008	

Figure 13. PowerFLAT™ (5x5) package dimensions



8 Revision history

Table 12. Document revision history

Date	Revision	Changes
31-Jul-2007	1	First release
29-Jan-2008	2	Added: <i>Section 3: Impedance on page 5, Section 4: Typical performance on page 6, Section 5: Test circuit on page 8, Section 6: Circuit layout and photo on page 10</i>
15-Jul-2008	3	Marking change from 8406 to 84006 see <i>Table 1</i>

Please Read Carefully:

Information in this document is provided solely in connection with ST products. STMicroelectronics NV and its subsidiaries ("ST") reserve the right to make changes, corrections, modifications or improvements, to this document, and the products and services described herein at any time, without notice.

All ST products are sold pursuant to ST's terms and conditions of sale.

Purchasers are solely responsible for the choice, selection and use of the ST products and services described herein, and ST assumes no liability whatsoever relating to the choice, selection or use of the ST products and services described herein.

No license, express or implied, by estoppel or otherwise, to any intellectual property rights is granted under this document. If any part of this document refers to any third party products or services it shall not be deemed a license grant by ST for the use of such third party products or services, or any intellectual property contained therein or considered as a warranty covering the use in any manner whatsoever of such third party products or services or any intellectual property contained therein.

UNLESS OTHERWISE SET FORTH IN ST'S TERMS AND CONDITIONS OF SALE ST DISCLAIMS ANY EXPRESS OR IMPLIED WARRANTY WITH RESPECT TO THE USE AND/OR SALE OF ST PRODUCTS INCLUDING WITHOUT LIMITATION IMPLIED WARRANTIES OF MERCHANTABILITY, FITNESS FOR A PARTICULAR PURPOSE (AND THEIR EQUIVALENTS UNDER THE LAWS OF ANY JURISDICTION), OR INFRINGEMENT OF ANY PATENT, COPYRIGHT OR OTHER INTELLECTUAL PROPERTY RIGHT.

UNLESS EXPRESSLY APPROVED IN WRITING BY AN AUTHORIZED ST REPRESENTATIVE, ST PRODUCTS ARE NOT RECOMMENDED, AUTHORIZED OR WARRANTED FOR USE IN MILITARY, AIR CRAFT, SPACE, LIFE SAVING, OR LIFE SUSTAINING APPLICATIONS, NOR IN PRODUCTS OR SYSTEMS WHERE FAILURE OR MALFUNCTION MAY RESULT IN PERSONAL INJURY, DEATH, OR SEVERE PROPERTY OR ENVIRONMENTAL DAMAGE. ST PRODUCTS WHICH ARE NOT SPECIFIED AS "AUTOMOTIVE GRADE" MAY ONLY BE USED IN AUTOMOTIVE APPLICATIONS AT USER'S OWN RISK.

Resale of ST products with provisions different from the statements and/or technical features set forth in this document shall immediately void any warranty granted by ST for the ST product or service described herein and shall not create or extend in any manner whatsoever, any liability of ST.

ST and the ST logo are trademarks or registered trademarks of ST in various countries.

Information in this document supersedes and replaces all information previously supplied.

The ST logo is a registered trademark of STMicroelectronics. All other names are the property of their respective owners.

© 2008 STMicroelectronics - All rights reserved

STMicroelectronics group of companies

Australia - Belgium - Brazil - Canada - China - Czech Republic - Finland - France - Germany - Hong Kong - India - Israel - Italy - Japan - Malaysia - Malta - Morocco - Singapore - Spain - Sweden - Switzerland - United Kingdom - United States of America

www.st.com