

PCM1690 24-Bit, 192-kHz Sampling, Enhanced Multi-Level $\Delta\Sigma$, Eight-Channel Audio Digital-to-Analog Converter

1 Features

- 24-Bit Delta-Sigma DAC
- 8-Channel DAC:
 - High Performance: Differential, $f_S = 48$ kHz
 - THD+N: -94 dB
 - SNR: 113 dB
 - Dynamic Range: 113 dB
 - Sampling Rate: 8 kHz to 192 kHz
 - System Clock: 128 f_S , 192 f_S , 256 f_S , 384 f_S , 512 f_S , 768 f_S , 1152 f_S
 - Differential Voltage Output: 8 V_{PP}
 - Analog Lowpass Filter Included
 - 4x/8x Oversampling Digital Filter:
 - Passband Ripple: ± 0.0018 dB
 - Stop Band Attenuation: -75 dB
 - Zero Flag
- Flexible Audio Interface:
 - I/F Format: I²S™, Left-/Right-Justified, DSP, TDM
 - Data Length: 16, 20, 24, 32 Bits
- Flexible Mode Control:
 - 3-Wire SPI, 2-Wire I²C-Compatible Serial Control Interface, or Hardware Control
- Multiple Functions Through SPI or I²C I/F:
 - Audio I/F Format Select: I²S, Left-Justified, Right-Justified, DSP, TDM
 - Digital Attenuation and Soft Mute
 - Digital De-Emphasis: 32 kHz, 44.1 kHz, 48 kHz
 - Data Polarity Control
 - Power Down
- Multiple Functions Through H/W Control:
 - Audio I/F Format Select: I²S, TDM
 - Digital De-Emphasis Filter: 44.1 kHz
- Analog Mute by Clock Halt Detection
- External RESET Pin
- Power Supplies:
 - 5 V for Analog and 3.3 V for Digital
- Package: HTSSOP-48
- Operating Temperature Range:
 - -40°C to $+85^\circ\text{C}$

2 Applications

- Blu-ray™ DVD Players
- HD DVD Players
- AV Receivers
- Home Theaters
- Car Audio External Amplifiers
- Car Audio AVN Applications

3 Description

The PCM1690 device is a high-performance, single-chip, 24-bit, eight-channel, audio digital-to-analog converter (DAC) with differential outputs. The eight-channel, 24-bit DAC employs an enhanced, multi-level delta-sigma ($\Delta\Sigma$) modulator and supports 8-kHz to 192-kHz sampling rates and a 16-/20-/24-/32-bit width digital audio input word on the audio interface. The audio interface of the PCM1690 supports the time-division-multiplexed (TDM) format in addition to the standard I²S, left-justified, right-justified, and DSP formats.

The PCM1690 can be controlled through a three-wire, SPI-compatible interface, or two-wire, I²C-compatible serial interface in software, which provides access to all functions including digital attenuation, soft mute, de-emphasis, and so forth. Also, hardware control mode provides a subset of user-programmable functions through two control pins. The PCM1690 is available in a 12-mm × 8-mm (12-mm × 6-mm body) HTSSOP-48 package.

Device Information⁽¹⁾

PART NUMBER	PACKAGE	BODY SIZE (NOM)
PCM1690	HTSSOP (48)	12.50 mm × 6.10 mm

(1) For all available packages, see the orderable addendum at the end of the data sheet.

Simplified Application Diagram

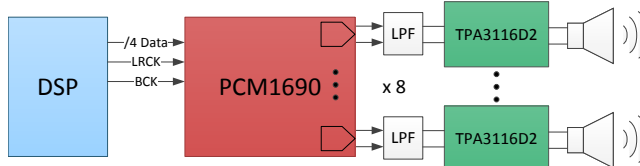

5 Pin Configuration and Functions

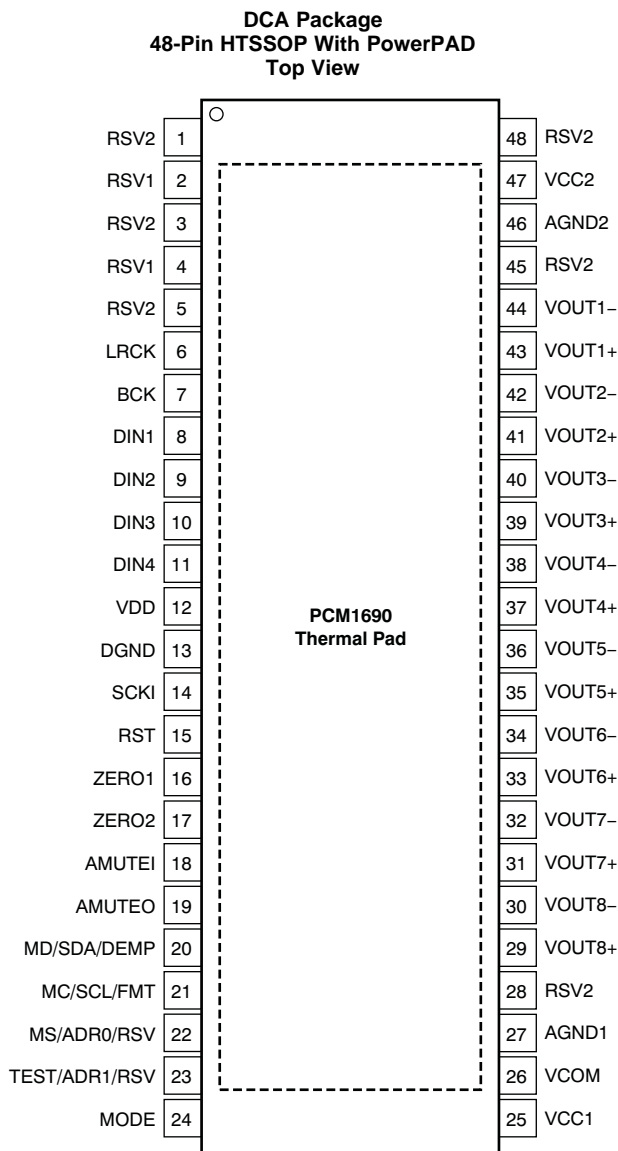

Pin Functions

PIN		I/O	PULLDOWN	5-V TOLERANT	DESCRIPTION
NAME	PIN				
RSV2	1	—	—	—	Reserved, tied to analog ground
RSV1	2	—	—	—	Reserved, left open
RSV2	3	—	—	—	Reserved, tied to analog ground
RSV1	4	—	—	—	Reserved, left open
RSV2	5	—	—	—	Reserved, tied to analog ground
LRCK	6	I	Yes	No	Audio data word clock input
BCK	7	I	Yes	No	Audio data bit clock input
DIN1	8	I	No	No	Audio data input for DAC1 and DAC2
DIN2	9	I	No	No	Audio data input for DAC3 and DAC4
DIN3	10	I	No	No	Audio data input for DAC5 and DAC6

Pin Functions (continued)

PIN		I/O	PULLDOWN	5-V TOLERANT	DESCRIPTION
NAME	PIN				
DIN4	11	I	No	No	Audio data input for DAC7 and DAC8
VDD	12	—	—	—	Digital power supply, +3.3 V
DGND	13	—	—	—	Digital ground
SCKI	14	I	No	Yes	System clock input
RST	15	I	Yes	Yes	Reset and power-down control input with active low
ZERO1	16	O	No	No	Zero detect flag output 1
ZERO2	17	O	No	No	Zero detect flag output 2
AMUTEI	18	I	No	Yes	Analog mute control input with active low
AMUTEO	19	O	No	Yes	Analog mute status output ⁽¹⁾ with active low
MD/SDA/DEMP	20	I/O	No	Yes	Input data for SPI, data for I ² C ⁽¹⁾ , de-emphasis control for hardware control mode
MC/SCL/FMT	21	I	No	Yes	Clock for SPI, clock for I ² C, format select for hardware control mode
MS/ADR0/RSV	22	I	Yes	Yes	Chip Select for SPI, address select 0 for I ² C, reserve (set low) for hardware control mode
TEST/ADR1/RSV	23	I/O	No	Yes	Test (factory use, left open) for SPI, address select 1 for I ² C, reserve (set low) for hardware control mode
MODE	24	I	No	No	Control port mode selection. Tied to VDD: SPI, left open: H/W mode, tied to DGND: I ² C
VCC1	25	—	—	—	Analog power supply 1, +5 V
VCOM	26	—	—	—	Voltage common decoupling
AGND1	27	—	—	—	Analog ground 1
RSV2	28	—	—	—	Reserved, tied to analog ground
VOUT8+	29	O	No	No	Positive analog output from DAC8
VOUT8-	30	O	No	No	Negative analog output from DAC8
VOUT7+	31	O	No	No	Positive analog output from DAC7
VOUT7-	32	O	No	No	Negative analog output from DAC7
VOUT6+	33	O	No	No	Positive analog output from DAC6
VOUT6-	34	O	No	No	Negative analog output from DAC6
VOUT5+	35	O	No	No	Positive analog output from DAC5
VOUT5-	36	O	No	No	Negative analog output from DAC5
VOUT4+	37	O	No	No	Positive analog output from DAC4
VOUT4-	38	O	No	No	Negative analog output from DAC4
VOUT3+	39	O	No	No	Positive analog output from DAC3
VOUT3-	40	O	No	No	Negative analog output from DAC3
VOUT2+	41	O	No	No	Positive analog output from DAC2
VOUT2-	42	O	No	No	Negative analog output from DAC2
VOUT1+	43	O	No	No	Positive analog output from DAC1
VOUT1-	44	O	No	No	Negative analog output from DAC1
RSV2	45	—	—	—	Reserved, tied to analog ground
AGND2	46	—	—	—	Analog ground 2
VCC2	47	—	—	—	Analog power supply 2, +5 V
RSV2	48	—	—	—	Reserved, tied to analog ground

(1) Open-drain configuration in out mode.

6 Specifications

6.1 Absolute Maximum Ratings

Over operating free-air temperature range (unless otherwise noted).⁽¹⁾

PARAMETER		MIN	MAX	UNIT
Supply voltage	VCC1, VCC2	-0.3	6.5	V
	VDD	-0.3	4	V
Ground voltage differences	AGND1, AGND2, DGND	-0.1	0.1	V
Supply voltage differences	VCC1, VCC2	-0.1	0.1	V
Digital input voltage	RST, TEST, MS, MC, MD, SCKI, AMUTEI, AMUTEO	-0.3	6.5	V
	BCK, LRCK, DIN1/2/3/4, MODE, ZERO1, ZERO2	-0.3	$(VDD + 0.3) < 4$	V
Analog input voltage	VCOM, VOUT1-8±	-0.3	$(VCC + 0.3) < 6.5$	V
Input current	(all pins except supplies)	-10	10	mA
Ambient temperature under bias		-40	125	°C
Junction temperature			150	°C
Lead temperature	(soldering, 5s)		260	°C
Package temperature	(IR reflow, peak)		260	°C
Storage temperature	T _{stg}	-55	150	°C

(1) Stresses beyond those listed under *Absolute Maximum Ratings* may cause permanent damage to the device. These are stress ratings only and functional operation of the device at these or any other conditions beyond those indicated under *Recommended Operating Conditions* is not implied. Exposure to absolute-maximum-rated conditions for extended periods may affect device reliability.

6.2 ESD Ratings

		VALUE	UNIT
V _(ESD) Electrostatic discharge	Human body model (HBM), per ANSI/ESDA/JEDEC JS-001 ⁽¹⁾	±1000	V
	Charged-device model (CDM), per JEDEC specification JESD22-C101 ⁽²⁾	±250	

(1) JEDEC document JEP155 states that 500-V HBM allows safe manufacturing with a standard ESD control process.

(2) JEDEC document JEP157 states that 250-V CDM allows safe manufacturing with a standard ESD control process.

6.3 Recommended Operating Conditions

Over operating free-air temperature range (unless otherwise noted).

		MIN	NOM	MAX	UNIT
Analog supply voltage, VCC		4.5	5	5.5	V
Digital supply voltage, VDD		3	3.3	3.6	V
Digital Interface		LVTTTL compatible			
Digital input clock frequency	Sampling frequency, LRCK	8		192	kHz
	System clock frequency, SCKI	2.048		36.864	MHz
Analog output voltage	Differential		8		V _{PP}
Analog output load resistance	To AC-coupled GND	5			kΩ
	To DC-coupled GND	15			kΩ
Analog output load capacitance				50	pF
Digital output load capacitance				20	pF
Operating free-air temperature	PCM1690 consumer grade	-40	25	85	°C

6.4 Thermal Information

THERMAL METRIC ⁽¹⁾		PCM1690	UNIT
		DCA (HTSSOP)	
		48 PINS	
R _{θJA}	Junction-to-ambient thermal resistance	29.2	°C/W
R _{θJC(top)}	Junction-to-case (top) thermal resistance	10.2	°C/W
R _{θJB}	Junction-to-board thermal resistance	10.3	°C/W
ψ _{JT}	Junction-to-top characterization parameter	0.3	°C/W
ψ _{JB}	Junction-to-board characterization parameter	10.2	°C/W
R _{θJC(bot)}	Junction-to-case (bottom) thermal resistance	0.4	°C/W

(1) For more information about traditional and new thermal metrics, see the *Semiconductor and IC Package Thermal Metrics* application report, [SPRA953](#).

6.5 Electrical Characteristics: Digital Input/Output

All specifications at T_A = 25°C, VCC1 = VCC2 = 5 V, VDD = 3.3 V, f_S = 48 kHz, SCKI = 512 f_S, 24-bit data, and Sampling Mode = Auto, unless otherwise noted.

PARAMETER		TEST CONDITIONS	MIN	TYP	MAX	UNIT
DATA FORMAT						
f _S	Sampling frequency		8	48	192	kHz
	System clock frequency	128 f _S , 192 f _S , 256 f _S , 384 f _S , 512 f _S , 768 f _S , 1152 f _S	2.048		36.864	MHz
INPUT LOGIC						
V _{IH}	Input logic level, high (BCK, LRCK, and DIN ^{(1) (2)})		2		VDD	VDC
V _{IL}	Input logic level, low (BCK, LRCK, and DIN ^{(1) (2)})				0.8	VDC
V _{IH}	Input logic current, high (SCKI, ADR5/ADR1/RSV, MC/SCL/FMT, MD/SDA/DEMP, and AMUTEI ^{(3) (4)})		2		5.5	VDC
V _{IL}	Input logic current, low (SCKI, ADR5/ADR1/RSV, MC/SCL/FMT, MD/SDA/DEMP, and AMUTEI ^{(3) (4)})				0.8	VDC
I _{IH}	Input logic current, high (SCKI, TEST/ADR1/RSV, MC/SCL/FMT, MD/SDA/DEMP, and AMUTEI ^{(2) (3)})	V _{IN} = VDD			±10	μA
I _{IL}	Input logic current, low (SCKI, TEST/ADR1/RSV, MC/SCL/FMT, MD/SDA/DEMP, and AMUTEI ^{(2) (3)})	V _{IN} = 0 V			±10	μA
I _{IH}	Input logic current, high (BCK, LRCK, REST, MSI/ADR0/RSV ^{(1) (4)})	V _{IN} = VDD		65	100	μA
I _{IL}	Input logic current, low (BCK, LRCK, REST, MSI/ADR0/RSV ^{(1) (4)})	V _{IN} = 0 V			±10	μA
OUTPUT LOGIC						
V _{OH}	Output logic level, high (ZERO1 and ZERO2 ⁽⁵⁾)	I _{OUT} = -4 mA	2.4			VDC
V _{OL}	Output logic level, low (ZERO1 and ZERO2 ^{(5) (6)})	I _{OUT} = +4 mA			0.4	VDC
REFERENCE OUTPUT						
	VCOM output voltage			0.5 × VCC1		V
	VCOM output impedance			7.5		kΩ
	Allowable VCOM output source/sink current				1	μA

- (1) BCK and LRCK (Schmitt trigger input with 50-kΩ typical internal pull-down resistor).
 (2) DIN1/2/3/4 (Schmitt trigger input).
 (3) SCKI, TEST/ADR1/RSV, MC/SCL/FMT, MD/SDA/DEMP, and AMUTEI (Schmitt trigger input, 5-V tolerant).
 (4) RST and MSI/ADR0/RSV (Schmitt trigger input with 50-kΩ typical internal pull-down resistor, 5-V tolerant).
 (5) ZERO1 and ZERO2.
 (6) SDA (I²C mode, open-drain low output) and AMUTE0 (open-drain low output).

6.6 Electrical Characteristics: DAC

All specifications at $T_A = 25^\circ\text{C}$, $V_{CC1} = V_{CC2} = 5\text{ V}$, $V_{DD} = 3.3\text{ V}$, $f_S = 48\text{ kHz}$, $\text{SCKI} = 512 f_S$, 24-bit data, and Sampling Mode = Auto, unless otherwise noted.

PARAMETER		TEST CONDITIONS	MIN	TYP	MAX	UNIT
RESOLUTION			16	24		Bits
DC ACCURACY						
Gain mismatch channel-to-channel				± 2	± 6	% of FSR
Gain error				± 2	± 6	% of FSR
Bipolar zero error				± 1		% of FSR
DYNAMIC PERFORMANCE^{(1) (2)}						
THD+N	Total harmonic distortion + noise	$f_S = 48\text{ kHz}$, $V_{OUT} = 0\text{ dB}$		-94	-88	dB
		$f_S = 96\text{ kHz}$, $V_{OUT} = 0\text{ dB}$		-94		dB
		$f_S = 192\text{ kHz}$, $V_{OUT} = 0\text{ dB}$		-94		dB
Dynamic range		$f_S = 48\text{ kHz}$, EIAJ, A-weighted	106	113		dB
		$f_S = 96\text{ kHz}$, EIAJ, A-weighted		113		dB
		$f_S = 192\text{ kHz}$, EIAJ, A-weighted		113		dB
SNR	Signal-to-noise ratio	$f_S = 48\text{ kHz}$, EIAJ, A-weighted	106	113		dB
		$f_S = 96\text{ kHz}$, EIAJ, A-weighted		113		dB
		$f_S = 192\text{ kHz}$, EIAJ, A-weighted		113		dB
Channel separation (between one channel and others)		$f_S = 48\text{ kHz}$	103	109		dB
		$f_S = 96\text{ kHz}$		109		dB
		$f_S = 192\text{ kHz}$		108		dB
ANALOG OUTPUT						
Output voltage	Differential			$1.6 \times V_{CC1}$		V_{PP}
Center voltage				$0.5 \times V_{CC1}$		V
Load impedance	To AC-coupled GND ⁽³⁾		5			k Ω
	To DC-coupled GND ⁽³⁾		15			k Ω
LPF frequency response	$f = 20\text{ kHz}$			-0.04		dB
	$f = 44\text{ kHz}$			-0.18		dB
DIGITAL FILTER PERFORMANCE WITH SHARP ROLL-OFF						
Passband (single, dual)	Except $\text{SCKI} = 128 f_S$ and $192 f_S$			$0.454 \times f_S$		Hz
	$\text{SCKI} = 128 f_S$ and $192 f_S$			$0.432 \times f_S$		Hz
Passband (quad)				$0.432 \times f_S$		Hz
Stop band (single, dual)	Except $\text{SCKI} = 128 f_S$ and $192 f_S$		$0.546 \times f_S$			Hz
	$\text{SCKI} = 128 f_S$ and $192 f_S$		$0.569 \times f_S$			Hz
Stop band (quad)			$0.569 \times f_S$			Hz
Passband ripple	$< 0.454 \times f_S$, $0.432 \times f_S$			± 0.0018		dB
Stop band attenuation	$> 0.546 \times f_S$, $0.569 \times f_S$			-75		dB

(1) In differential mode at $V_{OUTx\pm}$ pin, $f_{OUT} = 1\text{ kHz}$, using Audio Precision System II, Average mode with 20-kHz LPF and 400-Hz HPF.

(2) $f_S = 48\text{ kHz}$: $\text{SCKI} = 512 f_S$ (single), $f_S = 96\text{ kHz}$: $\text{SCKI} = 256 f_S$ (dual), $f_S = 192\text{ kHz}$: $\text{SCKI} = 128 f_S$ (quad).

(3) Allowable minimum input resistance of differential to single-ended converter with D to S Gain = G is calculated as $(1 + 2G)/(1 + G) \times 5\text{ k}$ for AC-coupled and $(1 + 0.9G)/(1 + G) \times 15\text{ k}$ for DC-coupled connection; refer to [Figure 39](#) and [Figure 40](#) of the [Application Information](#) section.

Electrical Characteristics: DAC (continued)

All specifications at $T_A = 25^\circ\text{C}$, $V_{CC1} = V_{CC2} = 5\text{ V}$, $V_{DD} = 3.3\text{ V}$, $f_S = 48\text{ kHz}$, $SCKI = 512 f_S$, 24-bit data, and Sampling Mode = Auto, unless otherwise noted.

PARAMETER	TEST CONDITIONS	MIN	TYP	MAX	UNIT
DIGITAL FILTER PERFORMANCE WITH SLOW ROLL-OFF					
Passband				$0.328 \times f_S$	Hz
Stop band		$0.673 \times f_S$			Hz
Passband ripple	$< 0.328 \times f_S$			± 0.0013	dB
Stop band attenuation	$> 0.673 \times f_S$	-75			dB
DIGITAL FILTER PERFORMANCE					
Group delay time (single, dual)	Except $SCKI = 128 f_S$ and $192 f_S$		$28/f_S$		s
	$SCKI = 128 f_S$ and $192 f_S$		$19/f_S$		s
Group delay time (quad)			$19/f_S$		s
De-emphasis error			± 0.1		dB

6.7 Electrical Characteristics: Power-Supply Requirements

All specifications at $T_A = 25^\circ\text{C}$, $V_{CC1} = V_{CC2} = 5\text{ V}$, $V_{DD} = 3.3\text{ V}$, $f_S = 48\text{ kHz}$, $SCKI = 512 f_S$, 24-bit data, and Sampling Mode = Auto, unless otherwise noted.

PARAMETER	TEST CONDITIONS	MIN	TYP	MAX	UNIT	
POWER-SUPPLY REQUIREMENTS						
$V_{CC1/2}$	Voltage range		4.5	5	5.5	VDC
V_{DD}			3	3.3	3.6	VDC
I_{CC}	Supply current	$f_S = 48\text{ kHz}$		74	110	mA
		$f_S = 192\text{ kHz}$		74		mA
		Full power-down ⁽¹⁾		170		μA
I_{DD}	Supply current	$f_S = 48\text{ kHz}$		57	90	mA
		$f_S = 192\text{ kHz}$		76		mA
		Full power-down ⁽¹⁾		60		μA
Power dissipation	$f_S = 48\text{ kHz}$ $f_S = 192\text{ kHz}$ Full power-down ⁽¹⁾		558	847		mW
			621			mW
			1.05			mW
TEMPERATURE RANGE						
Operating temperature	PCM1690 Consumer grade	-40		85	$^\circ\text{C}$	

(1) SCKI, BCK, and LRCK stopped.

6.8 System Clock Timing Requirements

(see [Figure 1](#))

		MIN	MAX	UNIT
t_{SCY}	System clock cycle time	27		ns
t_{SCH}	System clock width high	10		ns
t_{SCL}	System clock width low	10		ns
—	System clock duty cycle	40%	60%	

6.9 Audio Interface Timing Requirements for Left-Justified, Right-Justified, and I2S Data Formats

 (see [Figure 2](#))

		MIN	MAX	UNIT
t_{BCY}	BCK cycle time	75		ns
t_{BCH}	BCK pulse width high	35		ns
t_{BCL}	BCK pulse width low	35		ns
t_{LRS}	LRCK set-up time to BCK rising edge	10		ns
t_{LRH}	LRCK hold time to BCK rising edge	10		ns
t_{DIS}	DIN1/2/3/4 set-up time to BCK rising edge	10		ns
t_{DIH}	DIN1/2/3/4 hold time to BCK rising edge	10		ns

6.10 Audio Interface Timing Requirements for DSP and TDM Data Formats

 (see [Figure 3](#))

		MIN	MAX	UNIT
t_{BCY}	BCK cycle time	40		ns
t_{BCH}	BCK pulse width high	15		ns
t_{BCL}	BCK pulse width low	15		ns
t_{LRW}	LRCK pulse width high (DSP format)	t_{BCY}	t_{BCY}	
	LRCK pulse width high (TDM format)	t_{BCY}	$1/f_S - t_{BCY}$	
t_{LRS}	LRCK set-up time to BCK rising edge	10		ns
t_{LRH}	LRCK hold time to BCK rising edge	10		ns
t_{DIS}	DIN1/2/3/4 set-up time to BCK rising edge	10		ns
t_{DIH}	DIN1/2/3/4 hold time to BCK rising edge	10		ns

6.11 Three-Wire Serial Control Interface Timing Requirements

 (see [Figure 4](#))

		MIN	MAX	UNIT
t_{MCY}	MC pulse cycle time	100		ns
t_{MCL}	MC low-level time	40		ns
t_{MCH}	MC high-level time	40		ns
t_{MHH}	MS high-level time	t_{MCY}		ns
t_{MSS}	MS falling edge to MC rising edge	30		ns
t_{MSH}	MS rising edge from MC rising edge for LSB	15		ns
t_{MDH}	MD hold time	15		ns
t_{MDS}	MD set-up time	15		ns

6.12 SCL and SDA Control Interface Timing Requirements

 (see [Figure 5](#))

		STANDARD MODE		FAST MODE		UNIT
		MIN	MAX	MIN	MAX	
f_{SCL}	SCL clock frequency		100		400	kHz
t_{BUF}	Bus free time between STOP and START condition	4.7		1.3		μ s
t_{LOW}	Low period of the SCL clock	4.7		1.3		μ s
t_{HI}	High period of the SCL clock	4		0.6		μ s
t_{S-SU}	Set-up time for START/Repeated START condition	4.7		0.6		μ s
t_{S-HD}	Hold time for START/Repeated START condition	4.0		0.6		μ s
t_{D-SU}	Data set-up time	250		100		ns
t_{D-HD}	Data hold time	0	3450	0	900	ns
t_{SCL-R}	Rise time of SCL signal		1000	$20 + 0.1 C_B$	300	ns

SCL and SDA Control Interface Timing Requirements (continued)

(see Figure 5)

		STANDARD MODE		FAST MODE		UNIT
		MIN	MAX	MIN	MAX	
t_{SCL-F}	Fall time of SCL signal		1000	$20 + 0.1 C_B$	300	ns
t_{SDA-R}	Rise time of SDA signal		1000	$20 + 0.1 C_B$	300	ns
t_{SDA-F}	Fall time of SDA signal		1000	$20 + 0.1 C_B$	300	ns
t_{P-SU}	Set-up time for STOP condition	4		0.6		μs
t_{GW}	Allowable glitch width		N/A		50	
C_B	Capacitive load for SDA and SCL line		400		100	pF
V_{NH}	Noise margin at high level for each connected device (including hysteresis)	$0.2 \times V_{DD}$		$0.2 \times V_{DD}$		V
V_{NL}	Noise margin at low level for each connected device (including hysteresis)	$0.1 \times V_{DD}$		$0.1 \times V_{DD}$		V
V_{HYS}	Hysteresis of Schmitt trigger input	N/A		$0.05 \times V_{DD}$		V

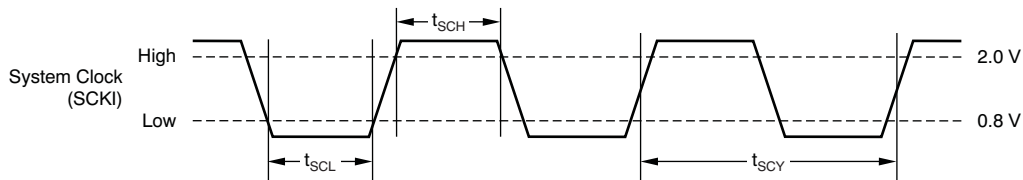

Figure 1. System Clock Timing Requirements

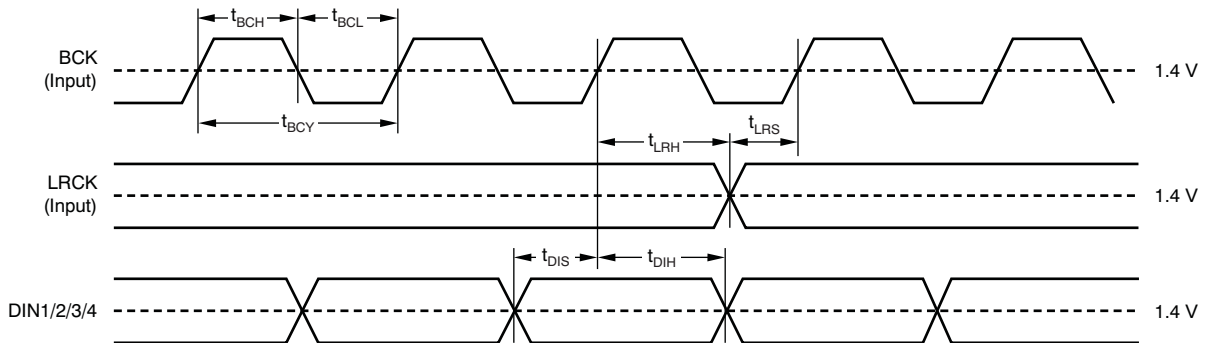

Figure 2. Audio Interface Timing Requirements for Left-Justified, Right-Justified, and I²S Data Formats

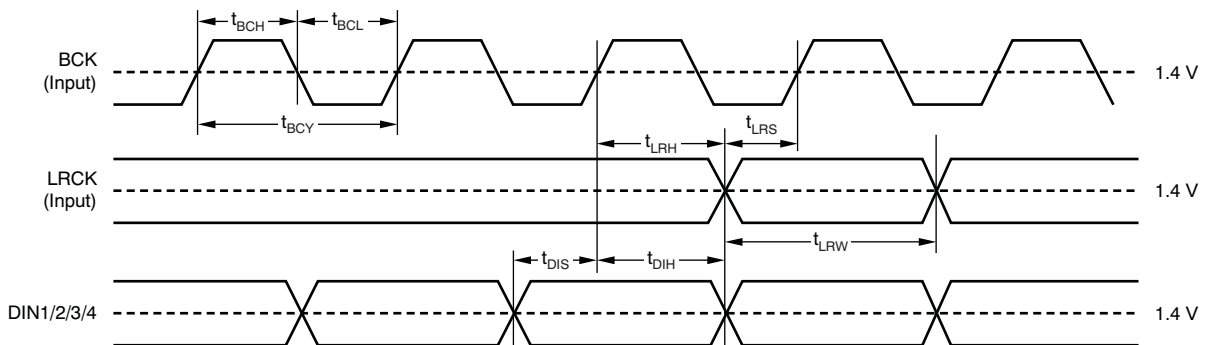

Figure 3. Audio Interface Timing Requirements for DSP and TDM Data Formats

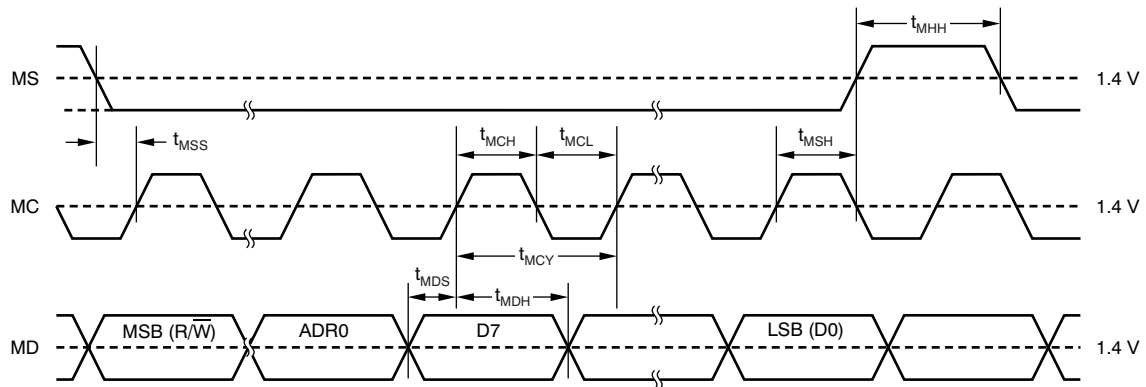

Figure 4. Three-Wire Serial Control Interface Timing

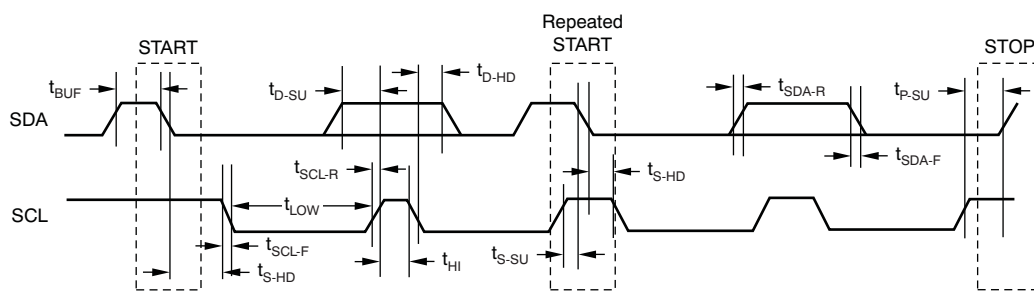

Figure 5. SCL and SDA Control Interface Timing

6.13 Typical Characteristics

6.13.1 Digital Filter

All specifications at $T_A = 25^\circ\text{C}$, $V_{CC1} = V_{CC2} = 5\text{ V}$, $V_{DD} = 3.3\text{ V}$, $f_S = 48\text{ kHz}$, $SCK1 = 512 f_S$, 24-bit data, and Sampling Mode = Auto, unless otherwise noted.

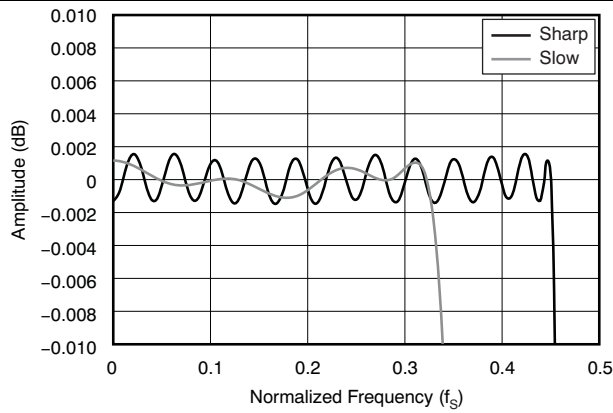

Figure 6. Frequency Response Passband (Single Rate)

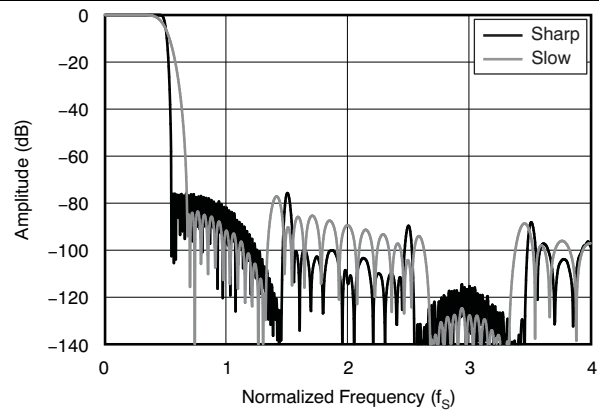

Figure 7. Frequency Response (Dual Rate)

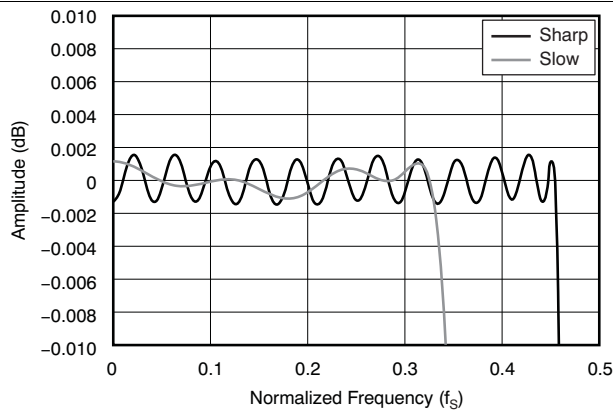

Figure 8. Frequency Response Passband (Dual Rate)

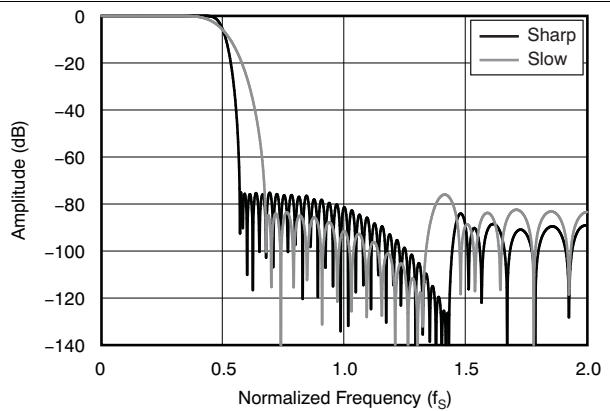

Figure 9. Frequency Response (Quad Rate)

Digital Filter (continued)

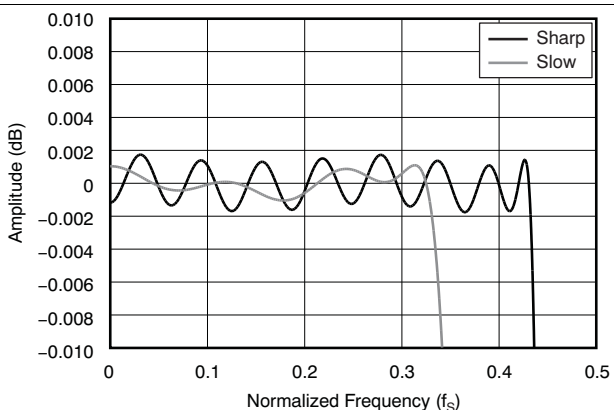

Figure 10. Frequency Response Passband (Quad Rate)

6.13.2 Digital De-Emphasis Filter

All specifications at $T_A = 25^\circ\text{C}$, $V_{CC1} = V_{CC2} = 5\text{ V}$, $V_{DD} = 3.3\text{ V}$, $f_S = 48\text{ kHz}$, $SCK1 = 512 f_S$, 24-bit data, and Sampling Mode = Auto, unless otherwise noted.

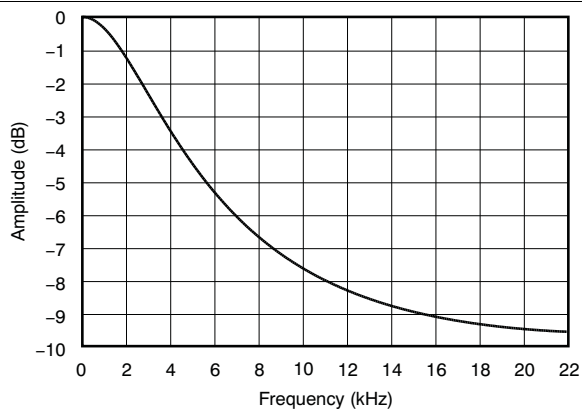

Figure 11. De-emphasis Characteristic

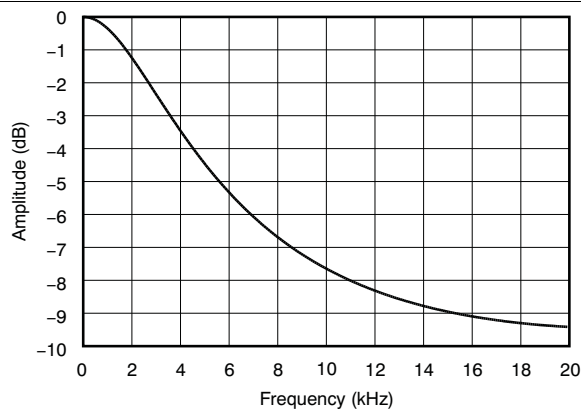
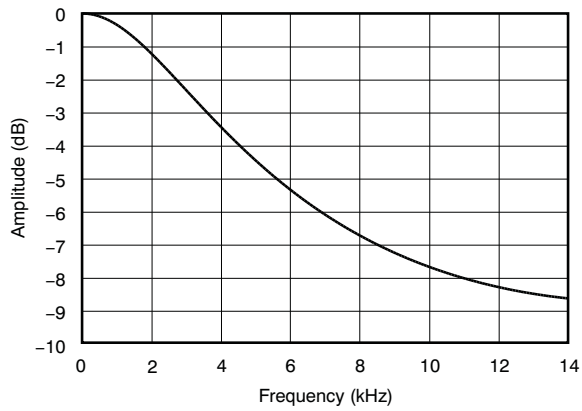

Figure 12. De-emphasis Characteristic

Digital De-Emphasis Filter (continued)



$f_s = 32 \text{ kHz}$

Figure 13. De-emphasis Characteristic

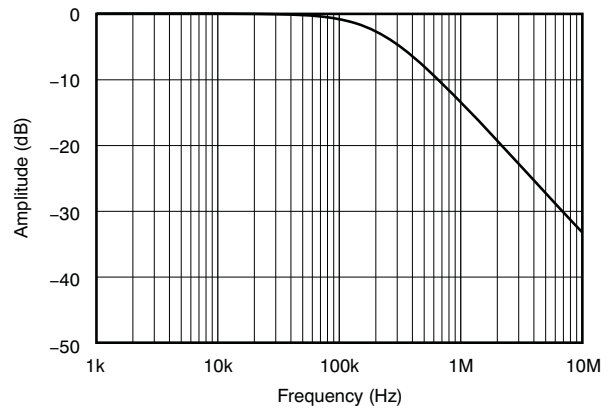

Figure 14. Analog Filter Characteristic

6.13.3 Dynamic Performance

All specifications at $T_A = 25^\circ\text{C}$, $V_{CC1} = V_{CC2} = 5\text{ V}$, $V_{DD} = 3.3\text{ V}$, $f_S = 48\text{ kHz}$, $SCKI = 512 f_S$, 24-bit data, and Sampling Mode = Auto, unless otherwise noted.

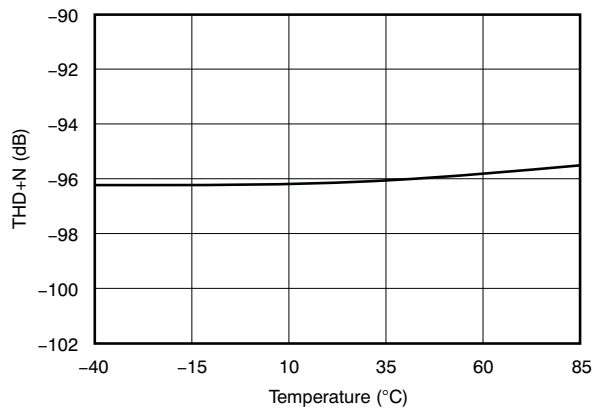

Figure 15. THD+N vs Temperature

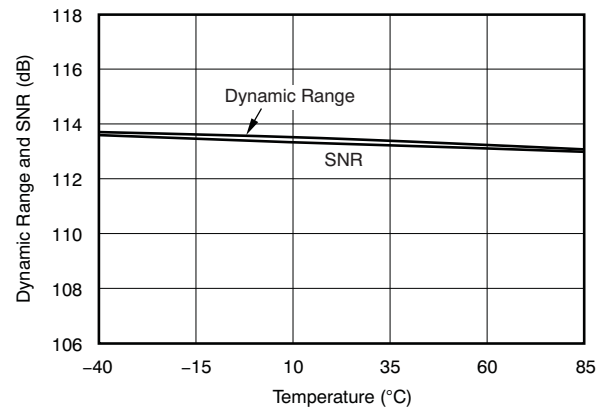

Figure 16. Dynamic Range and SNR vs Temperature

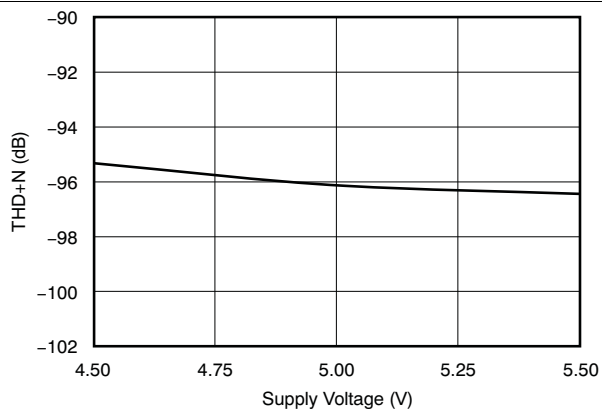

Figure 17. THD+N vs Supply Voltage

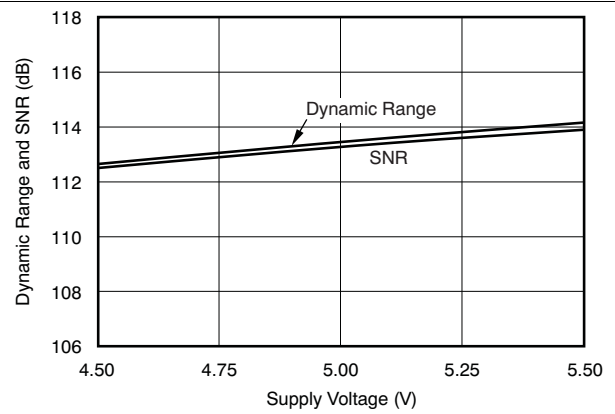
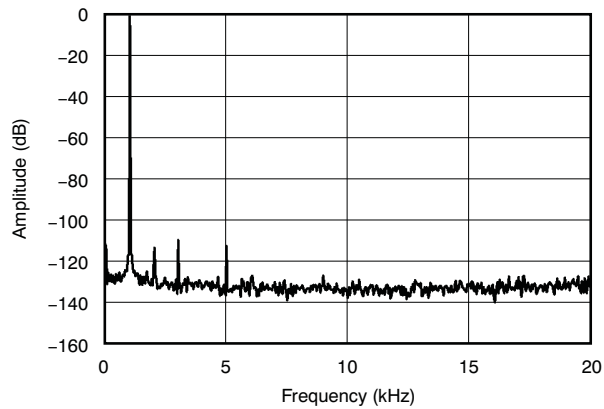

Figure 18. Dynamic Range and SNR vs Supply Voltage

PCM1690

SBAS448B –OCTOBER 2008–REVISED AUGUST 2015

www.ti.com
6.13.4 Output Spectrum

 All specifications at $T_A = 25^\circ\text{C}$, $V_{CC1} = V_{CC2} = 5\text{ V}$, $V_{DD} = 3.3\text{ V}$, $f_S = 48\text{ kHz}$, $SCKI = 512 f_S$, 24-bit data, and Sampling Mode = Auto, unless otherwise noted.

0 dB, N = 32768

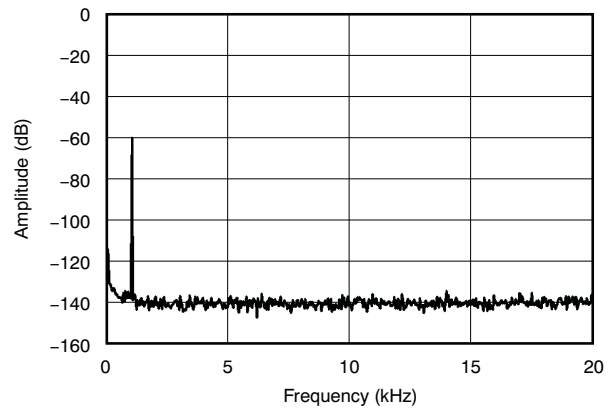
Figure 19. Output Spectrum

-60 dB, N = 32768

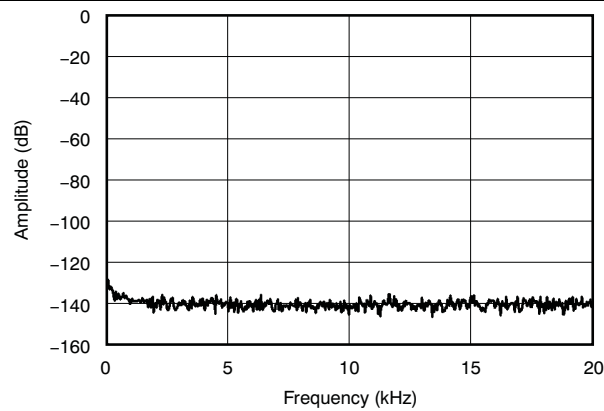
Figure 20. Output Spectrum

BPZ, N = 32768

Figure 21. Output Spectrum

7 Detailed Description

7.1 Overview

The PCM1690 is a high-performance, multi-channel DAC targeted for consumer audio applications such as Blu-ray DVD players and HD DVD players, as well as home multi-channel audio applications (such as home theaters and A/V receivers). The PCM1690 consists of an eight-channel DAC. The DAC output type is fixed with a differential configuration. The PCM1690 supports 16-/20-/24-/32-bit linear PCM input data in I²S- and left-justified audio formats, and 24-bit linear PCM input data in right-justified, DSP, and TDM formats for various sampling frequencies from 8 kHz to 192 kHz. The TDM format is useful for saving bus line interface numbers for multi-channel audio data communication between the DAC and a digital audio processor. The PCM1690 offers three modes for device control: two-wire I²C software, three-wire SPI software, and hardware modes.

- **Audio data interface formats:** I²S, LJ, RJ, DSP, TDM
- **Audio data word length:** 16, 20, 24, 32 Bits
- **Audio data format:** MSB first, twos complement

7.2 Functional Block Diagram

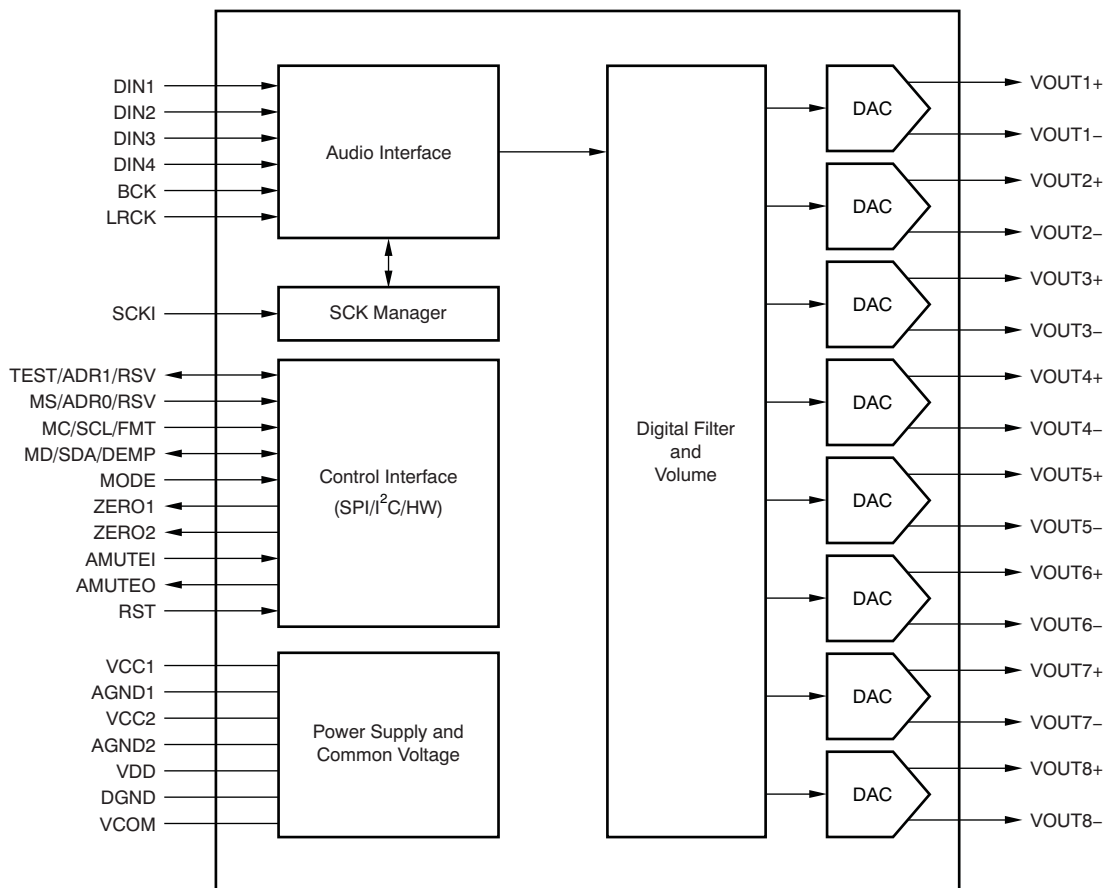

7.3 Feature Description

7.3.1 Analog Outputs

The PCM1690 includes eight DACs, each with individual pairs of differential voltage outputs pins. The full-scale output voltage is $(1.6 \times V_{CC1}) V_{PP}$ at the differential output mode. A DC-coupled load is allowed in addition to an AC-coupled load if the load resistance conforms to the specification. These balanced outputs are each capable of driving $0.8 V_{CC1}$ ($4 V_{PP}$) typical into a 5-k Ω , AC-coupled or 15-k Ω , DC-coupled load with $V_{CC1} = +5$ V. The internal output amplifiers for VOUT1 through VOUT8 are biased to the DC common voltage, equal to $(0.5 \times V_{CC1})$.

The output amplifiers include an RC continuous-time filter that helps to reduce the out-of-band noise energy present at the DAC outputs as a result of the noise shaping characteristics of the PCM1690 delta-sigma ($\Delta\Sigma$) DACs. The frequency response of this filter is shown in the *Analog Filter Characteristic* (Figure 14). By itself, this filter is not enough to attenuate the out-of-band noise to an acceptable level for most applications. An external lowpass filter is required to provide sufficient out-of-band noise rejection. Further discussion of DAC post-filter circuits is provided in the *Application Information* section.

Table 1. Pin Assignments in Differential Output Mode

DIGITAL INPUT	CHANNEL	DIFFERENTIAL OUTPUT
DIN1	1 (DAC1)	VOUT1+, VOUT1–
	2 (DAC2)	VOUT2+, VOUT2–
DIN2	3 (DAC3)	VOUT3+, VOUT3–
	4 (DAC4)	VOUT4+, VOUT4–
DIN3	5 (DAC5)	VOUT5+, VOUT5–
	6 (DAC6)	VOUT6+, VOUT6–
DIN4	7 (DAC7)	VOUT7+, VOUT7–
	8 (DAC8)	VOUT8+, VOUT8–

7.3.2 Voltage Reference VCOM

The PCM1690 includes a pin for the common-mode voltage output, VCOM. This pin must be connected to the analog ground through a decoupling capacitor. This pin can also be used to bias external high-impedance circuits, if they are required.

7.3.3 System Clock Input

The PCM1690 requires an external system clock input applied at the SCKI input for DAC operation. The system clock operates at an integer multiple of the sampling frequency, or f_S . The multiples supported in DAC operation include $128 f_S$, $192 f_S$, $256 f_S$, $384 f_S$, $512 f_S$, $768 f_S$, and $1152 f_S$. Details for these system clock multiples are shown in Table 2. Figure 1 and *System Clock Timing Requirements* show the SCKI timing requirements.

Table 2. System Clock Frequencies for Common Audio Sampling Rates

DEFAULT SAMPLING MODE	SAMPLING FREQUENCY	SYSTEM CLOCK FREQUENCY (MHz)						
	f_S (kHz)	$128 f_S$	$192 f_S$	$256 f_S$	$384 f_S$	$512 f_S$	$768 f_S$	$1152 f_S$
Single rate	8	N/A	N/A	2.0480	3.0720	4.0960	6.1440	9.2160
	16	2.0480	3.0720	4.0960	6.1440	8.1920	12.2880	18.4320
	32	4.0960	6.1440	8.1920	12.2880	16.3840	24.5760	36.8640
	44.1	5.6448	8.4672	11.2896	16.9344	22.5792	33.8688	N/A
	48	6.1440	9.2160	12.2880	18.4320	24.5760	36.8640	N/A
Dual rate	88.2	11.2896	16.9344	22.5792	33.8688	N/A	N/A	N/A
	96	12.2880	18.4320	24.5760	36.8640	N/A	N/A	N/A
Quad rate	176.4	22.5792	33.8688	N/A	N/A	N/A	N/A	N/A
	192	24.5760	36.8640	N/A	N/A	N/A	N/A	N/A

7.3.4 Sampling Mode

The PCM1690 supports three sampling modes (single rate, dual rate, and quad rate) in DAC operation. In single rate mode, the DAC operates at an oversampling frequency of x128 (except when SCK1 = 128 f_S and 192 f_S). This mode is supported for sampling frequencies less than 50 kHz. In dual rate mode, the DAC operates at an oversampling frequency of x64; this mode is supported for sampling frequencies less than 100 kHz. In quad rate mode, the DAC operates at an oversampling frequency of x32. The sampling mode is automatically selected according to the ratio of system clock frequency and sampling frequency by default (that is, single rate for 512 f_S, 768 f_S, and 1152 f_S; dual rate for 256 f_S and 384 f_S; and quad rate for 128 f_S and 192 f_S), but manual selection is also possible for specified combinations through the serial mode control register.

Table 3 and Figure 22 show the relation among the oversampling rate (OSR) of the digital filter and ΔΣ modulator, the noise-free shaped bandwidth, and each sampling mode setting.

Table 3. DAC Filter OSR, Modulator OSR, and Noise-Free Shaped Bandwidth for Each Sampling Mode

SAMPLING MODE REGISTER SETTING	SYSTEM CLOCK FREQUENCY (xf _S)	NOISE-FREE SHAPED BANDWIDTH (kHz) ⁽¹⁾			DIGITAL FILTER OSR	MODULATOR OSR
		f _S = 48 kHz	f _S = 96 kHz	f _S = 192 kHz		
Auto	512, 768, 1152	40	N/A	N/A	x8	x128
	256, 384	20	40	N/A	x8	x64
	128, 192 ⁽²⁾	10	20	40	x4	x32
Single	512, 768, 1152	40	N/A	N/A	x8	x128
	256, 384	40	N/A	N/A	x8	x128
	128, 192 ⁽²⁾	20	N/A	N/A	x4	x64
Dual	256, 384	20	40	N/A	x8	x64
	128, 192 ⁽²⁾	20	40	N/A	x4	x64
Quad	128, 192 ⁽²⁾	10	20	40	x4	x32

- (1) Bandwidth in which noise is shaped out.
 (2) Quad mode filter characteristic is applied.

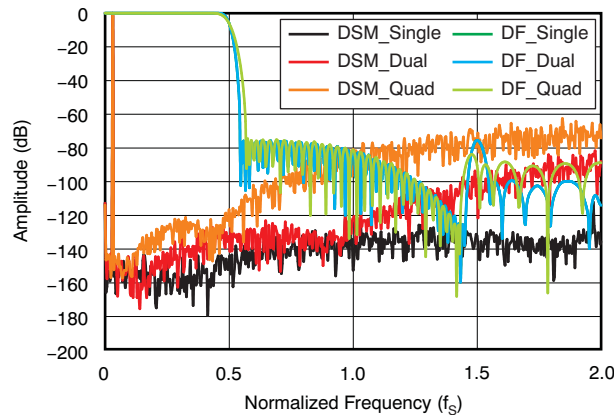

Figure 22. ΔΣ Modulator and Digital Filter Characteristic

7.3.5 Reset Operation

The PCM1690 has both an internal power-on reset circuit and an external reset circuit. The sequences for both reset circuits are shown in [Figure 23](#) and [Figure 24](#). [Figure 23](#) describes the timing at the internal power-on reset. Initialization is triggered automatically at the point where VDD exceeds 2.2 V typical, and the internal reset is released after 3846 SCKI clock cycles from power-on if RST is held high and SCKI is provided. VOUT from the DACs are forced to the VCOM level initially (that is, $0.5 \times VCC1$) and settle at a specified level according to the rising VCC. If synchronization among SCKI, BCK, and LRCK is maintained, VOUT provides an output that corresponds to DIN after 3846 SCKI clocks from power-on. If the synchronization is not held, the internal reset is not released, and both operating modes are maintained at reset and power-down states; after synchronization forms again, the DAC returns to normal operation with the previous sequences.

[Figure 24](#) shows a timing diagram at the external reset. RST accepts an externally-forced reset with RST low, and provides a device reset and power-down state that achieves the lowest power dissipation state available in the PCM1690. If RST goes from high to low under synchronization among SCKI, BCK, and LRCK, the internal reset is asserted, all registers and memory are reset, and finally the PCM1690 enters into all power-down states. At the same time, VOUT is immediately forced into the AGND1 level. To begin normal operation again, toggle RST high; the same power-up sequence is performed as the power-on reset shown in [Figure 23](#).

The PCM1690 does not require particular power-on sequences for VCC and VDD; it allows VDD on and then VCC on, or VCC on and then VDD on. From the viewpoint of the [Absolute Maximum Ratings](#), however, simultaneous power-on is recommended for avoiding unexpected responses on VOUTx. [Figure 23](#) shows the response for VCC on with VDD on.

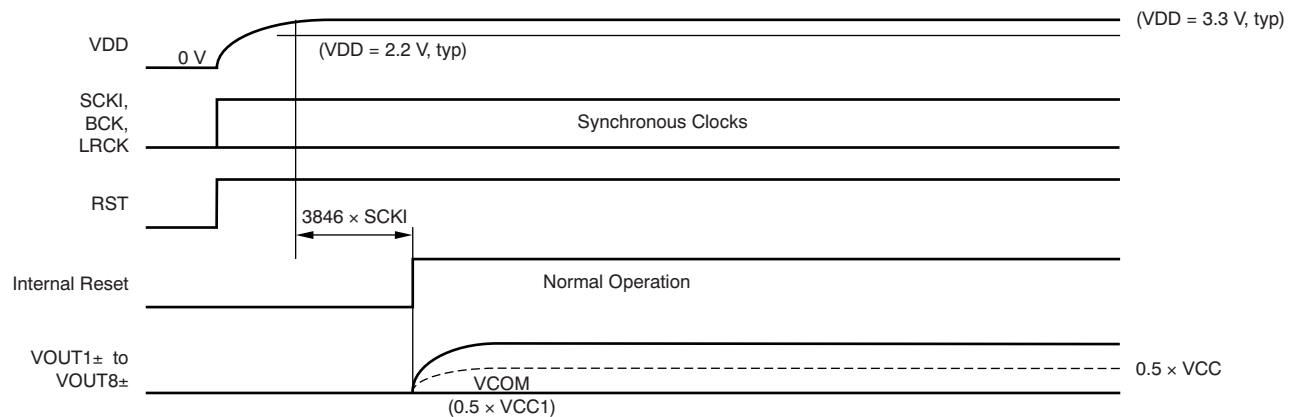

Figure 23. Power-On-Reset Timing Requirements

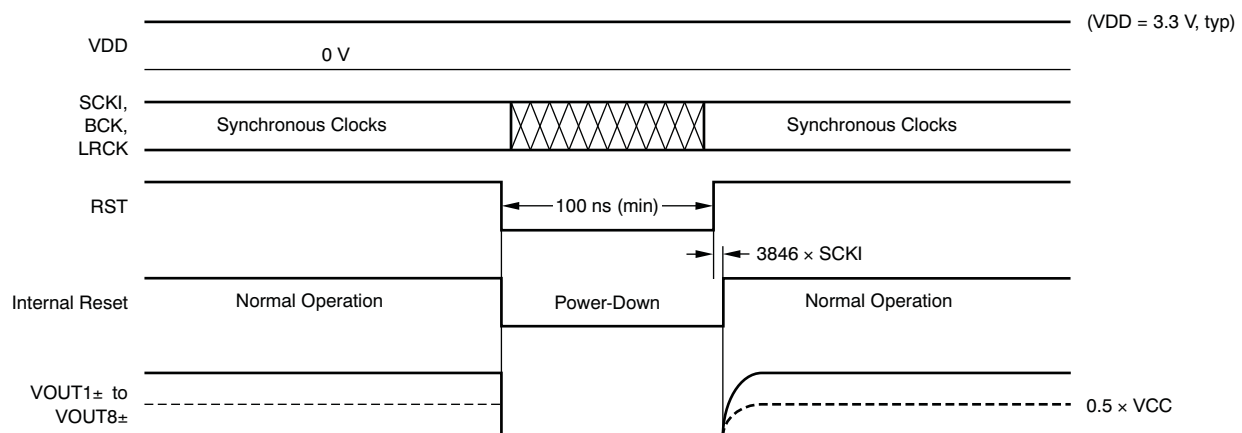

Figure 24. External Reset Timing Requirements

7.3.6 Zero Flag

The PCM1690 has two ZERO flag pins (ZERO1 and ZERO2) that can be assigned to the combinations shown in Table 4. Zero flag combinations are selected through control register settings. If the input data of the left and right channel of all assigned channels remain at '0' for 1024 sampling periods (LRCK clock periods), the ZERO1/2 bits are set to a high level, logic '1' state. Furthermore, if the input data of any channels of assigned channels read '1', the ZERO1/2 are set to a low level, logic '0' state, immediately. Zero data detection is supported for 16-/20-/24-bit data width, but is not supported for 32-bit data width.

The active polarity of the zero flag output can be inverted through control register settings. The reset default is active high for zero detection. In parallel hardware control mode, ZERO1 and ZERO2 are fixed with combination A shown in Table 4.

Table 4. Zero Flag Outputs Combination

ZERO FLAG COMBINATION	ZERO1	ZERO2
A	DATA1, left channel	DATA1, right channel
B	DATA1–4	DATA1–4
C	DATA4	DATA1–3
D	DATA1	DATA2–4

7.3.7 AMUTE Control

The PCM1690 has an AMUTE control input, status output pins, and functionality. AMUTEI is the input control pin of the internal analog mute circuit. An AMUTEI low input causes the DAC output to cut-off from the digital input and forces it to the center level (0.5 VCC1). AMUTEO is the status output pin of the internal analog mute circuit. AMUTEO low indicates the analog mute control circuit is active because of a programmed condition (such as an SCKI halt, asynchronous detect, zero detect, or issue with the DAC disable command) that forces the DAC outputs to a center level. Because AMUTEI is not terminated internally and AMUTEO is an open-drain output, pull-ups by the appropriate resistors are required for proper operation.

Additionally, because the AMUTEI pin control and power-down control in register (OPEDA when high, PSM DA when low) do not function together, AMUTEI takes priority over power-down control. Therefore, power-down control is ignored during AMUTEI low, and AMUTEI low forces the DAC output to a center level (0.5 VCC1) even if the power-down control is asserted.

7.3.8 Three-Wire (SPI) Serial Control

The PCM1690 includes an SPI-compatible serial port that operates asynchronously with the audio serial interface. The control interface consists of MD/SDA/DEMP, MC/SCL/FMT, and MS/ADR0/RSV. MD is the serial data input to program the mode control registers. MC is the serial bit clock that shifts the data into the control port. MS is the select input to enable the mode control port.

7.3.9 Control Data Word Format

All single write operations via the serial control port use 16-bit data words. Figure 25 shows the control data word format. The first bit (fixed at '0') is for write controls; after the first bit are seven other bits, labeled ADR[6:0] that set the register address for the write operation. The eight least significant bits (LSBs), D[7:0] on MD, contain the data to be written to the register specified by ADR[6:0].

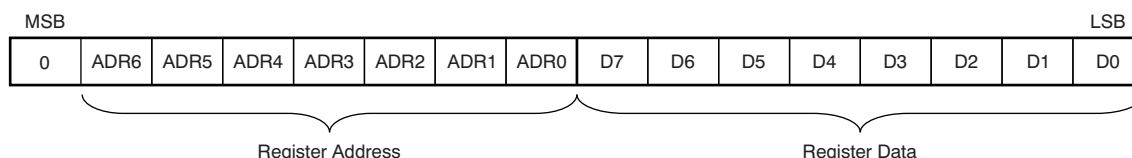

Figure 25. Control Data Word Format for MD

7.3.10 Register Write Operation

Figure 26 shows the functional timing diagram for single write operations on the serial control port. MS is held at a high state until a register is to be written. To start the register write cycle, MS is set to a low state. 16 clocks are then provided on MC, corresponding to the 16 bits of the control data word on MD. After the 16th clock cycle has been completed, MS is set high to latch the data into the indexed mode control register.

Also, the PCM1690 supports multiple write operations in addition to single write operations, which can be performed by sending the following N-times of the 8-bit register data after the first 16-bit register address and register data while keeping the MC clocks and MS at a low state. Closing a multiple write operation can be accomplished by setting MS to a high state.

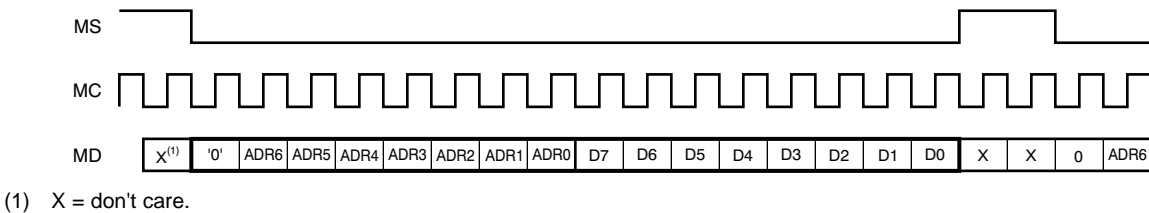

Figure 26. Register Write Operation

7.3.11 Two-Wire (I²C) Serial Control

The PCM1690 supports an I²C-compatible serial bus and data transmission protocol for fast mode configured as a slave device. This protocol is explained in the I²C specification 2.0.

The PCM1690 has a 7-bit slave address, as shown in Figure 27. The first five bits are the most significant bits (MSB) of the slave address and are factory-preset to 10011. The next two bits of the address byte are selectable bits that can be set by MS/ADR0/RSV and TEST/ADR1/RSV. A maximum of four PCM1690s can be connected on the same bus at any one time. Each PCM1690 responds when it receives its own slave address.

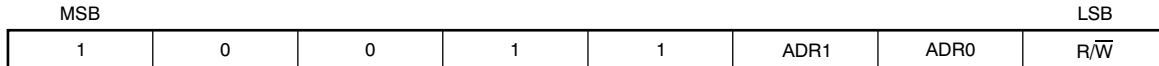
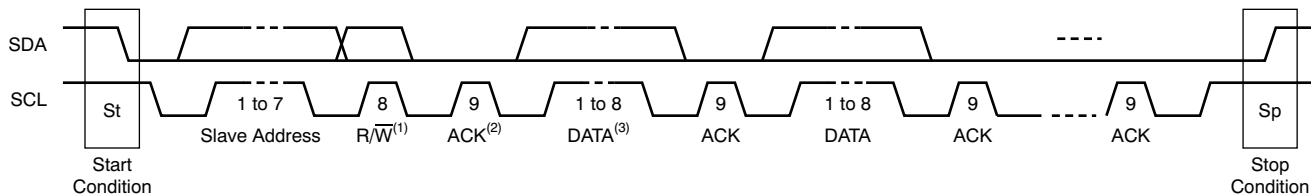

Figure 27. Slave Address

7.3.12 Packet Protocol

A master device must control the packet protocol, which consists of a start condition, slave address with the read/write bit, data if a write operation is required, acknowledgment if a read operation is required, and stop condition. The PCM1690 supports both slave receiver and transmitter functions. Details about DATA for both write and read operations are described in [Figure 28](#).



- (1) R/\bar{W} : Read operation if '1'; write operation otherwise.
- (2) ACK: Acknowledgment of a byte if '0', not Acknowledgment of a byte if '1'.
- (3) DATA: Eight bits (byte); details are described in the [Write Operation](#) and [Read Operation](#) sections.

Figure 28. I²C Packet Control Protocol

7.3.13 Write Operation

The PCM1690 supports a receiver function. A master device can write to any PCM1690 register using single or multiple accesses. The master sends a PCM1690 slave address with a write bit, a register address, and the data. If multiple access is required, the address is that of the starting register, followed by the data to be transferred. When valid data are received, the index register automatically increments by one. When the register address reaches &h4F, the next value is &h40. When undefined registers are accessed, the PCM1690 does not send an acknowledgment. [Figure 29](#) shows a diagram of the write operation. The register address and write data are in 8-bit, MSB-first format.

Transmitter	M	M	M	S	M	S	M	S	M	S	...	S	M
Data Type	St	Slave Address	\bar{W}	ACK	Reg Address	ACK	Write Data 1	ACK	Write Data 2	ACK	...	ACK	Sp

NOTE: M = Master device, S = Slave device, St = Start condition, \bar{W} = Write, ACK = Acknowledge, and Sp = Stop condition.

Figure 29. Framework for Write Operation

7.3.14 Read Operation

A master device can read the registers of the PCM1690. The value of the register address is stored in an indirect index register in advance. The master sends the PCM1690 slave address with a read bit after storing the register address. Then the PCM1690 transfers the data that the index register points to. [Figure 30](#) shows a diagram of the read operation.

Transmitter	M	M	M	S	M	S	M	M	M	S	S	M	M
Data Type	St	Slave Address	\bar{W}	ACK	Reg Address	ACK	Sr	Slave Address	R	ACK	Read Data	NACK	Sp

NOTE: M = Master device, S = Slave device, St = Start condition, Sr = Repeated start condition, \bar{W} = Write, R = Read, ACK = Acknowledge, NACK = Not acknowledge, and Sp = Stop condition.

NOTE: The slave address after the repeated start condition must be the same as the previous slave address.

Figure 30. Framework for Read Operation

7.3.15 Timing Requirements: SCL and SDA

A detailed timing diagram for SCL and SDA is shown in [Figure 5](#).

7.4 Device Functional Modes

7.4.1 Audio Serial Port Operation

The PCM1690 audio serial port consists of six signals: BCK, LRCK, DIN1, DIN2, DIN3, and DIN4. BCK is a bit clock input. LRCK is a left/right word clock input or frame synchronization clock input. DIN1/2/3/4 are the audio data inputs for VOUT1–8.

7.4.2 Audio Data Interface Formats and Timing

The PCM1690 supports 10 audio data interface formats: 16-/20-/24-/32-bit I²S, 16-/20-/24-/32-bit left-justified, 24-bit right-justified, 16-bit right-justified, 24-bit left-justified mode DSP, 24-bit I²S mode DSP, 24-bit left-justified mode TDM, 24-bit I²S mode TDM, 24-bit left-justified mode high-speed TDM, and 24-bit I²S mode high-speed TDM. In the case of I²S, left-justified, and right-justified data formats, 64 BCKs, 48 BCKs, and 32 BCKs per LRCK period are supported; but 48 BCKs are limited in 192/384/768 f_S SCKI, and 32 BCKs are limited in 16-bit right-justified only. In the case of TDM data format in single rate, BCK, LRCK, and DIN1 are used. In the case of TDM data format in dual rate, BCK, LRCK, and DIN1/2 are used. In the case of high-speed TDM format in dual rate, BCK, LRCK, and DIN1 are used. In the case of high-speed TDM format in quad rate, BCK, LRCK, and DIN1/2 are used. TDM format and high-speed TDM format are supported only at SCKI = 512 f_S, 256 f_S, 128 f_S, and f_{BCK} ≤ f_{SCKI}. The audio data formats are selected by MC/SCL/FMT in hardware control mode and by control register settings in software control mode. All data must be in binary two's complement and MSB first.

[Table 5](#) summarizes the applicable formats and describes the relationships among them and the respective restrictions with mode control. [Figure 31](#) through [Figure 37](#) show 10 audio interface data formats.

Table 5. Audio Data Interface Formats and Sampling Rate, Bit Clock, and System Clock Restrictions

CONTROL MODE	FORMAT	DATA BITS	MAX LRCK FREQUENCY (f _S)	SCKI RATE (xf _S)	BCK RATE (xf _S)	APPLICABLE PINS	
Software control	I ² S/Left-Justified	16/20/24/32 ⁽¹⁾	192 kHz	128 to 1152 ⁽²⁾	64, 48	DIN1/2/3/4	
	Right-Justified	24, 16	192 kHz	128 to 1152 ⁽²⁾	64, 48, 32 (16 bit) ⁽³⁾	DIN1/2/3/4	
	I ² S/Left-Justified DSP	24	192 kHz	128 to 768	64	DIN1/2/3/4	
	I ² S/ Left-Justified TDM	24	48 kHz	256, 512	256	DIN1	
	High-Speed I ² S/Left-Justified TDM		24	96 kHz	128, 256	128	DIN1/2
			24	192 kHz	128	128	DIN1/2
Hardware control	I ² S	16/20/24/32 ⁽¹⁾	192 kHz	128 to 1152 ⁽²⁾	64, 48	DIN1/2/3/4	
	I ² S TDM	24	48 kHz	512	256	DIN1	
		24	96 kHz	256	128	DIN1/2	

- (1) 32-bit data length is acceptable only for BCK = 64 f_S and when using I²S and Left-Justified format.
- (2) 1152 f_S is acceptable only for f_S = 32 kHz, BCK = 64 f_S, and when using I²S, Left-Justified, and 24-bit Right-Justified format.
- (3) BCK = 32 f_S is supported only for 16-bit data length.

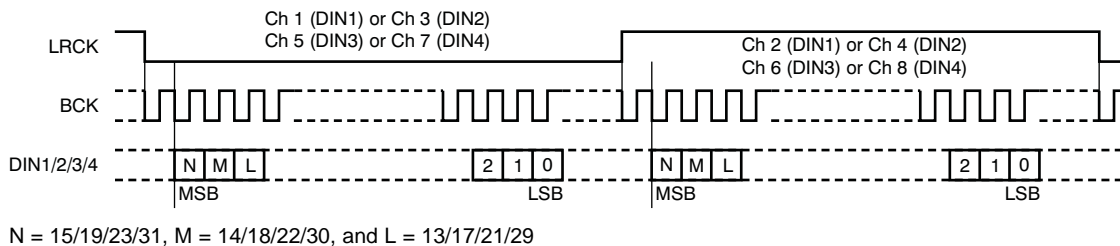

Figure 31. Audio Data Format: 16-/20-/24-/32-Bit I²S

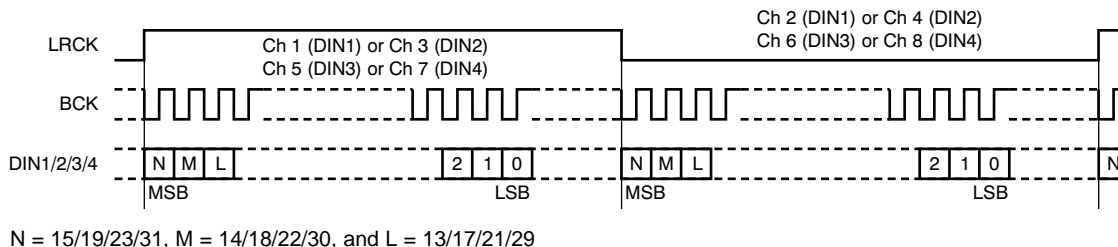

Figure 32. Audio Data Format: 16-/20-/24-/32-Bit Left-Justified

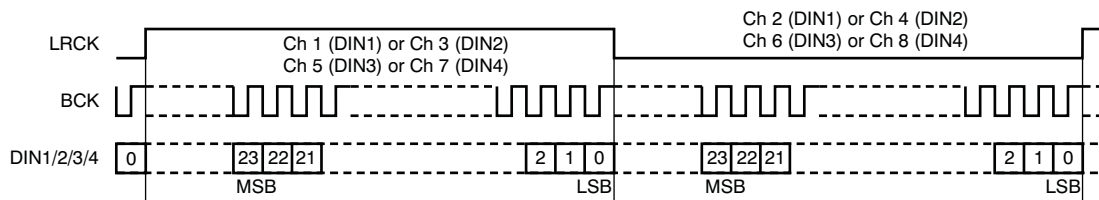

Figure 33. Audio Data Format: 24-Bit Right-Justified

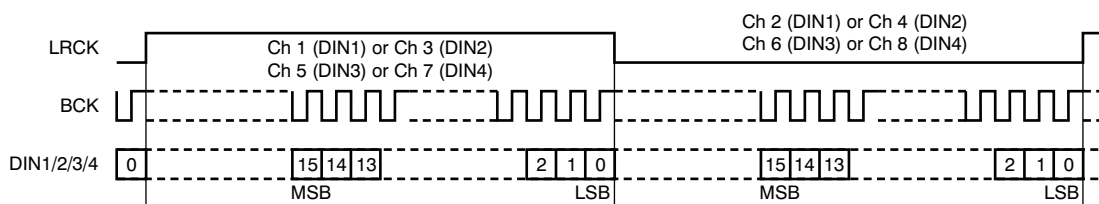

Figure 34. Audio Data Format: 16-Bit Right-Justified

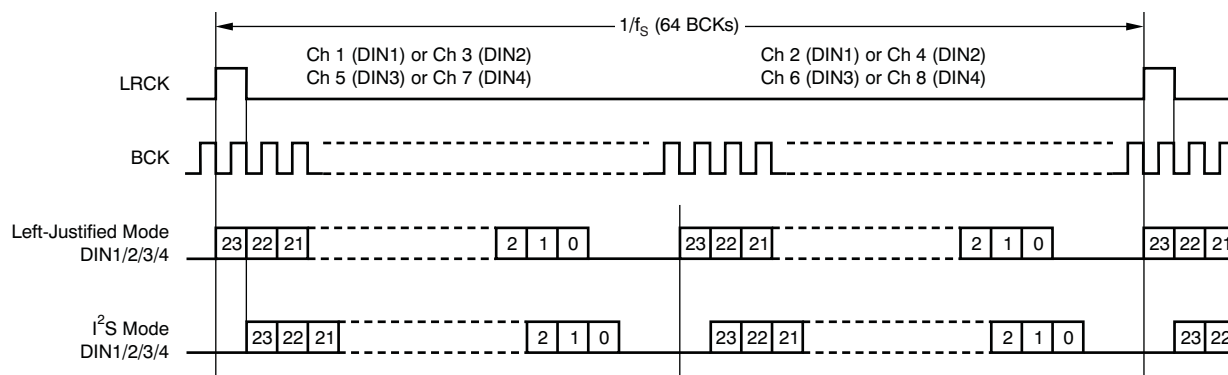

Figure 35. Audio Data Format: 24-Bit DSP Format

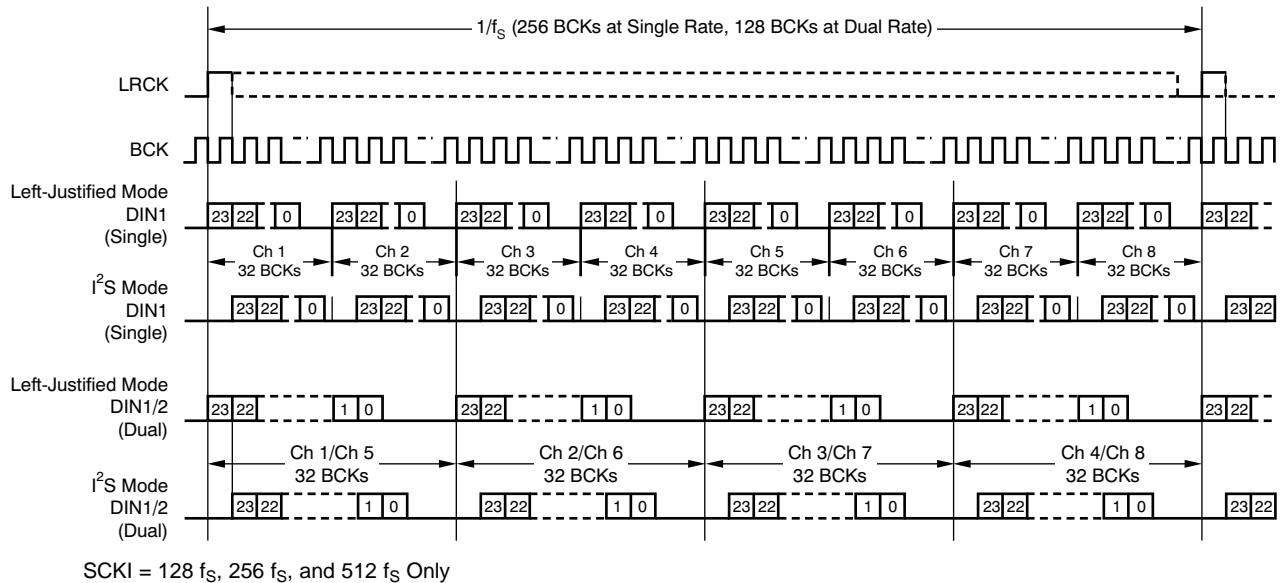

Figure 36. Audio Data Format: 24-Bit TDM Format

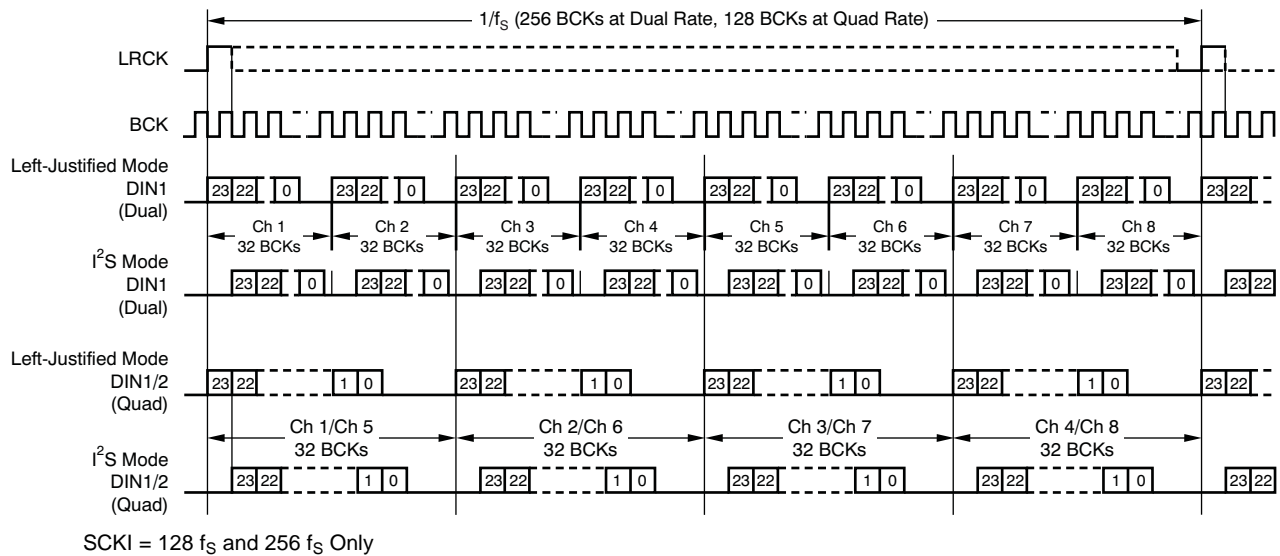

Figure 37. Audio Data Format: 24-Bit High-Speed TDM Format

7.4.3 Synchronization With the Digital Audio System

The PCM1690 operates under the system clock (SCKI) and the audio sampling rate (LRCK). Therefore, SCKI and LRCK must have a specific relationship. The PCM1690 does not need a specific phase relationship between the audio interface clocks (LRCK, BCK) and the system clock (SCKI), but does require a specific frequency relationship (ratiometric) between LRCK, BCK, and SCKI.

If the relationship between SCKI and LRCK changes more than ± 2 BCK clocks because of jitter, sampling frequency change, etc., the DAC internal operation stops within 1/f_s, and the analog output is forced into VCOM (0.5 VCC1) until re-synchronization between SCKI, LRCK, and BCK completes and then 38/f_s (single, dual rate) or 29/f_s (quad rate) passes. In the event the change is less than ± 2 BCKs, re-synchronization does not occur, and this analog output control and discontinuity does not occur.

Figure 38 shows the DAC analog output during loss of synchronization. During undefined data periods, some noise may be generated in the audio signal. Also, the transition of normal to undefined data and undefined (or zero) data to normal data creates a discontinuity of data on the analog outputs, which then may generate some noise in the audio signal.

DAC outputs (VOUTx) hold the previous state if the system clock halts, but the asynchronous and re-synchronization processes will occur after the system clock resumes.

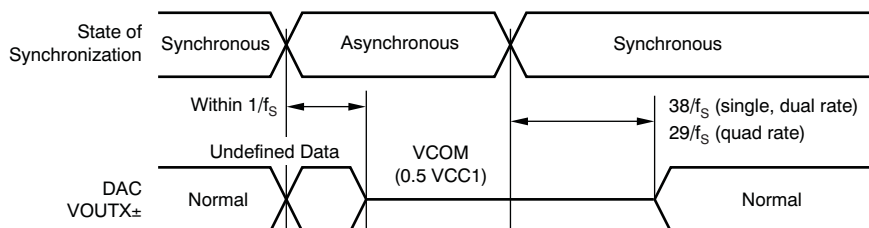

Figure 38. DAC Outputs During Loss of Synchronization

7.4.4 Mode Control

The PCM1690 includes three mode control interfaces with two oversampling configurations, depending on the input state of the MODE pin, as shown in Table 6. The pull-up and pull-down resistors must each be less than 10 kΩ.

Table 6. Mode Control Selection

MODE	MODE CONTROL INTERFACE
Tied to DGND, low	Two-wire (I ² C) serial control, selectable oversampling configuration
Left open	Two-wire parallel control, auto mode oversampling configuration
Tied to VDD, high	Three-wire (SPI) serial control, selectable oversampling configuration

The input state of the MODE pin is sampled at the moment of power-on, or during a low-to-high transition of the RST pin, with the system clock input. Therefore, input changes after reset are ignored until the next power-on or reset. From the mode control selection described in Table 6, the functions of four pins are changed, as shown in Table 7.

Table 7. Pin Functions for Interface Mode

PIN	PIN ASSIGNMENTS		
	SPI	I ² C	H/W
20	MD (input)	SDA (input/output)	DEMP (input)
21	MC (input)	SCL (input)	FMT (input)
22	MS (input)	ADR0 (input)	RSV (input, low)
23	Test (output, open)	ADR1 (input)	RSV (input, low)

In serial mode control, the actual mode control is performed by register writes (and reads) through the SPI- or I²C-compatible serial control port. In parallel mode control, two specific functions are controlled directly through the high/low control of two specific pins, as described in the following section.

7.4.5 Parallel Hardware Control

The functions shown in Table 8 and Table 9 are controlled by two pins, DEMP and FMT, in parallel hardware control mode. The DEMP pin controls the 44.1-kHz digital de-emphasis function of all eight channels. The FMT pin controls the audio interface format for all eight channels.

Table 8. DEMP Functionality

DEMP	DESCRIPTION
Low	De-emphasis off
High	44.1 kHz de-emphasis on

Table 9. FMT Functionality

FMT	DESCRIPTION
Low	16-/20-/24-/32-bit I ² S format
High	24-bit I ² S mode TDM format

7.5 Register Maps

7.5.1 Control Register Definitions (Software Mode Only)

The PCM1690 has many user-programmable functions that are accessed via control registers, and are programmed through the SPI or I²C serial control port. [Table 10](#) shows the available mode control functions along with reset default conditions and associated register address. [Table 11](#) lists the register map.

Table 10. User-Programmable Mode Control Functions

FUNCTION	RESET DEFAULT	REGISTER	LABEL
Mode control register reset	Normal operation	64	MRST
System reset	Normal operation	64	SRST
Analog mute function control	Mute disabled	64	AMUTE[3:0]
Sampling mode selection	Auto	64	SRDA[1:0]
Power-save mode selection	Power save	65	PSMDA
Audio interface format selection	I ² S	65	FMTDA[3:0]
Operation control	Normal operation	66	OPEDA[3:0]
Digital filter roll-off control	Sharp roll-off	66	FLT[3:0]
Output phase selection	Normal	67	REVDA[8:1]
Soft mute control	Mute disabled	68	MUTDA[8:1]
Zero flag	Not detected	69	ZERO[8:1]
Digital attenuation mode	0 dB to –63 dB, 0.5 dB step	70	DAMS
Digital de-emphasis function control	Disabled	70	DEMP[1:0]
Zero flag function selection	ZERO1: DIN1, left-channel ZERO2: DIN1, right-channel	70	AZRO[1:0]
Zero flag polarity selection	High for detection	70	ZREV
Digital attenuation level setting	0 dB, no attenuation	71–79	ATDAx[7:0]

Table 11. Register Map

ADR[6:0]		DATA[7:0]							
DEC	HEX	B7	B6	B5	B4	B3	B2	B1	B0
64	40	MRST	SRST	AMUTE3	AMUTE2	AMUTE1	AMUTE0	SRDA1	SRDA0
65	41	PSMDA	RSV ⁽¹⁾	RSV ⁽¹⁾	RSV ⁽¹⁾	FMTDA3	FMTDA2	FMTDA1	FMTDA0
66	42	OPEDA3	OPEDA2	OPEDA1	OPEDA0	FLT3	FLT2	FLT1	FLT0
67	43	REVDA8	REVDA7	REVDA6	REVDA5	REVDA4	REVDA3	REVDA2	REVDA1
68	44	MUTDA8	MUTDA7	MUTDA6	MUTDA5	MUTDA4	MUTDA3	MUTDA2	MUTDA1
69	45	ZERO8	ZERO7	ZERO6	ZERO5	ZERO4	ZERO3	ZERO2	ZERO1
70	46	DAMS	RSV ⁽¹⁾	DEMP1	DEMP0	RSV ⁽¹⁾	AZRO1	AZRO0	ZREV
71	47	RSV ⁽¹⁾	RSV ⁽¹⁾	RSV ⁽¹⁾	RSV ⁽¹⁾	RSV ⁽¹⁾	RSV ⁽¹⁾	RSV ⁽¹⁾	RSV ⁽¹⁾
72	48	ATDA17	ATDA16	ATDA15	ATDA14	ATDA13	ATDA12	ATDA11	ATDA10
73	49	ATDA27	ATDA26	ATDA25	ATDA24	ATDA23	ATDA22	ATDA21	ATDA20
74	4A	ATDA37	ATDA36	ATDA35	ATDA34	ATDA33	ATDA32	ATDA31	ATDA30
75	4B	ATDA47	ATDA46	ATDA45	ATDA44	ATDA43	ATDA42	ATDA41	ATDA40
76	4C	ATDA57	ATDA56	ATDA55	ATDA54	ATDA53	ATDA52	ATDA51	ATDA50
77	4D	ATDA67	ATDA66	ATDA65	ATDA64	ATDA63	ATDA62	ATDA61	ATDA60

(1) RSV must be set to '0'.

Table 11. Register Map (continued)

ADR[6:0]		DATA[7:0]							
DEC	HEX	B7	B6	B5	B4	B3	B2	B1	B0
78	4E	ATDA77	ATDA76	ATDA75	ATDA74	ATDA73	ATDA72	ATDA71	ATDA70
79	4F	ATDA87	ATDA86	ATDA85	ATDA84	ATDA83	ATDA82	ATDA81	ATDA80

7.5.2 Register Definitions

Table 12. Register 64 (Hex 40)

DEC	HEX	B7	B6	B5	B4	B3	B2	B1	B0
64	40	MRST	SRST	AMUTE3	AMUTE2	AMUTE1	AMUTE0	SRDA1	SRDA0

MRST	Mode control register reset	
	This bit sets the mode control register reset to the default value. Pop noise may be generated. Returning the MRST bit to '1' is unnecessary because it is automatically set to '1' after the mode control register is reset.	
	Default value = 1.	
	MRST	Mode control register reset
	0	Set default value
	1	Normal operation (default)
SRST	System reset	
	This bit controls the system reset, which includes the resynchronization between the system clock and sampling clock, and DAC operation restart. The mode control register is not reset and the PCM1789 does not go into a power-down state. Returning the SRST bit to '1' is unnecessary; it is automatically set to '1' after triggering a system reset.	
	Default value = 1.	
	SRST	System reset
	0	Resynchronization
	1	Normal operation (default)
AMUTE[3:0]	Analog mute function control	
	These bits control the enabling/disabling of each source event that triggers the analog mute control circuit.	
	Default value = 0000.	
	AMUTE	Analog mute function control
	xxx0	Disable analog mute control by SCKI halt
	xxx1	Enable analog mute control by SCKI halt
	xx0x	Disable analog mute control by asynchronous detect
	xx1x	Enable analog mute control by asynchronous detect
	x0xx	Disable analog mute control by ZERO1 and ZERO2 detect
	x1xx	Enable analog mute control by ZERO1 and ZERO2 detect
0xxx	Disable analog mute control by DAC disable command	
1xxx	Enable analog mute control by DAC disable command	
SRDA[1:0]	Sampling mode selection	
	These bits control the sampling mode of DAC operation. In Auto mode, the sampling mode is automatically set according to multiples between the system clock and sampling clock: single rate for 512 f_S , 768 f_S , and 1152 f_S , dual rate for 256 f_S or 384 f_S , and quad rate for 128 f_S and 192 f_S .	
	Default value = 00.	
	SRDA	Sampling mode selection
	00	Auto (default)
	01	Single rate
10	Dual rate	
	11	Quad rate

Table 13. Register 65 (Hex 41)

DEC	HEX	B7	B6	B5	B4	B3	B2	B1	B0
65	41	PSMDA	RSV	RSV	RSV	FMTDA3	FMTDA2	FMTDA1	FMTDA0
PSMDA	Power-save mode selection								
	This bit selects the power-save mode for the OPEDA[3:0] function. When PSMDA = 0, OPEDA[3:0] controls the power-save mode and normal operation. When PSMDA = 1, OPEDA functions controls the DAC disable (not power-save mode) and normal operation. Default value: 0.								
	PSMDA	Power-save mode selection							
	0	Power-save enable mode (default)							
1	Power-save disable mode								
RSV	Reserved Reserved; do not use.								
FMTDA[3:0]	Audio interface format selection								
	These bits control the audio interface format for DAC operation. Details of the format, and any related restrictions with the system clock are described in the Audio Data Interface Formats and Timing section. Default value: 0000 (16-/20-/24-/32-bit I ² S format).								
	FMTDA	Audio interface format selection							
	0000	16-/20-/24-/32-bit I ² S format (default)							
	0001	16-/20-/24-/32-bit left-justified format							
	0010	24-bit right-justified format							
	0011	16-bit right-justified format							
	0100	24-bit I ² S mode DSP format							
	0101	24-bit left-justified mode DSP format							
	0110	24-bit I ² S mode TDM format							
	0111	24-bit left-justified mode TDM format							
	1000	24-bit high-speed I ² S mode TDM format							
	1001	24-bit high-speed left-justified mode TDM format							
	101x	Reserved							
11xx	Reserved								
1	Slow roll-off								

Table 14. Register 66 (Hex 42)

DEC	HEX	B7	B6	B5	B4	B3	B2	B1	B0
66	42	OPEDA3	OPEDA2	OPEDA1	OPEDA0	FLT3	FLT2	FLT1	FLT0
OPEDA[3:0]	Operation control								
	These bits control the DAC operation mode. In operation disable mode, the DAC output is cut off from DIN and the internal DAC data are reset. If PSMDA = 1, the DAC output is forced into VCOM. If PSMDA = 0, the DAC output is forced into AGND and the DAC goes into a power-down state. For normal operating mode, these bits must be '0'. The serial mode control is effective during operation disable mode. Default value: 0000.								
	OPEDA	Operation control							
	xxx0	DAC1/2 normal operation							
	xxx1	DAC1/2 operation disable with or without power save							
	xx0x	DAC3/4 normal operation							
	xx1x	DAC3/4 operation disable with or without power save							
	x0xx	DAC5/6 normal operation							
	x1xx	DAC5/6 operation disable with or without power save							
	0xxx	DAC7/8 normal operation							
1xxx	DAC7/8 operation disable with or without power save								

FLT[3:0]	Digital filter roll-off control	
	These bits allow users to select the digital filter roll-off that is best suited to their applications. Sharp and slow filter roll-off selections are available. The filter responses for these selections are shown in the Typical Characteristics section of this data sheet.	
	Default value: 0000.	
	FLT	Digital filter roll-off control
	xxx0	DAC1/2 sharp roll-off
	xxx1	DAC1/2 slow roll-off
	xx0x	DAC3/4 sharp roll-off
	xx1x	DAC3/4 slow roll-off
	x0xx	DAC5/6 sharp roll-off
	x1xx	DAC5/6 slow roll-off
0xxx	DAC7/8 sharp roll-off	
1xxx	DAC7/8 slow roll-off	

Table 15. Register 67 (Hex 43)

DEC	HEX	B7	B6	B5	B4	B3	B2	B1	B0
67	43	REVDA8	REVDA7	REVDA6	REVDA5	REVDA4	REVDA3	REVDA2	REVDA1

REVDA[8:1]	Output phase selection	
	These bits are used to control the phase of DAC analog signal outputs.	
	Default value: 0000 0000.	
	REVDA	Output phase selection
	xxxx xxx0	DAC1 normal output
	xxxx xxx1	DAC1 inverted output
	xxxx xx0x	DAC2 normal output
	xxxx xx1x	DAC2 inverted output
	xxxx x0xx	DAC3 normal output
	xxxx x1xx	DAC3 inverted output
	xxxx 0xxx	DAC4 normal output
	xxxx 1xxx	DAC4 inverted output
	xxx0 xxxx	DAC5 normal output
	xxx1 xxxx	DAC5 inverted output
	xx0x xxxx	DAC6 normal output
	xx1x xxxx	DAC6 inverted output
	x0xx xxxx	DAC7 normal output
	x1xx xxxx	DAC7 inverted output
0xxx xxxx	DAC8 normal output	
1xxx xxxx	DAC8 inverted output	

Table 16. Register 68 (Hex 44)

DEC	HEX	B7	B6	B5	B4	B3	B2	B1	B0
68	44	MUTDA8	MUTDA7	MUTDA6	MUTDA5	MUTDA4	MUTDA3	MUTDA2	MUTDA1

MUTDA[8:1]	Soft Mute control	
	These bits are used to enable or disable the Soft Mute function for the corresponding DAC outputs, VOUT. The Soft Mute function is incorporated into the digital attenuators. When mute is disabled (MUTDA[8:1] = 0), the attenuator and DAC operate normally. When mute is enabled by setting MUTDA[8:1] = 1, the digital attenuator for the corresponding output is decreased from the current setting to infinite attenuation. By setting MUTDA[8:1] = 0, the attenuator is increased to the last attenuation level in the same manner as it is for decreasing levels. This configuration reduces <i>pop and zipper noise</i> during muting of the DAC output. This Soft Mute control uses the same resource of digital attenuation level setting. Mute control has priority over the digital attenuation level setting.	
	Default value: 0000 0000.	

MUTDA	Soft Mute control
xxxx xxx0	DAC1 Mute disabled
xxxx xxx1	DAC1 Mute enabled
xxxx xx0x	DAC2 Mute disabled
xxxx xx1x	DAC2 Mute enabled
xxxx x0xx	DAC3 Mute disabled
xxxx x1xx	DAC3 Mute enabled
xxxx 0xxx	DAC4 Mute disabled
xxxx 1xxx	DAC4 Mute enabled
xxx0 xxxx	DAC5 Mute disabled
xxx1 xxxx	DAC5 Mute enabled
xx0x xxxx	DAC6 Mute disabled
xx1x xxxx	DAC6 Mute enabled
x0xx xxxx	DAC7 Mute disabled
x1xx xxxx	DAC7 Mute enabled
0xxx xxxx	DAC8 Mute disabled
1xxx xxxx	DAC8 Mute enabled

Table 17. Register 69 (Hex 45)

DEC	HEX	B7	B6	B5	B4	B3	B2	B1	B0
69	45	ZERO8	ZERO7	ZERO6	ZERO5	ZERO4	ZERO3	ZERO2	ZERO1

ZERO[8:1]	Zero flag (read-only)
	These bits indicate the present status of the zero detect circuit for each DAC channel; these bits are read-only.
ZERO	Zero flag
xxxx xxx0	DAC1 zero input not detected
xxxx xxx1	DAC1 zero input detected
xxxx xx0x	DAC2 zero input not detected
xxxx xx1x	DAC2 zero input detected
xxxx x0xx	DAC3 zero input not detected
xxxx x1xx	DAC3 zero input detected
xxxx 0xxx	DAC4 zero input not detected
xxxx 1xxx	DAC4 zero input detected
xxx0 xxxx	DAC5 zero input not detected
xxx1 xxxx	DAC5 zero input detected
xx0x xxxx	DAC6 zero input not detected
xx1x xxxx	DAC6 zero input detected
x0xx xxxx	DAC7 zero input not detected
x1xx xxxx	DAC7 zero input detected
0xxx xxxx	DAC8 zero input not detected
1xxx xxxx	DAC8 zero input detected

Table 18. Register 70 (Hex 46)

DEC	HEX	B7	B6	B5	B4	B3	B2	B1	B0
70	46	DAMS	RSV	DEMP1	DEMP0	RSV	AZRO1	AZRO0	ZREV
DAMS	Digital attenuation mode								
	This bit selects the attenuation mode. Default value: 0.								
	DAMS	Digital attenuation mode							
	0	Fine step: 0.5-dB step for 0 dB to –63 dB range (default)							
1	Wide range: 1-dB step for 0 dB to –100 dB range								
RSV	Reserved								
	Reserved; do not use.								
DEMP[1:0]	Digital de-emphasis function/sampling rate control								
	These bits are used to disable or enable the various sampling frequencies of the digital de-emphasis function. Default value: 00.								
	DEMP	Digital de-emphasis function/sampling rate control							
	00	Disable (default)							
	01	48 kHz enable							
10	44.1 kHz enable								
11	32 kHz enable								
AZRO[1:0]	Zero flag channel combination selection								
	The AZRO[1:0] bits are used to select the zero flag channel combination for ZERO1 and ZERO2. If the analog mute function control by ZERO flags is used, AZRO[1:0] must not be set '00'; otherwise, analog mute works even if the data of DATA2–4 are not zero. Default value: 00 _B .								
	AZRO	Zero flag combination selection							
	00	Combination A: ZERO1 = DATA1 left channel, ZERO2 = DATA1 right channel (default)							
	01	Combination B: ZERO1 = DATA1–4, ZERO2 = DATA1–4							
10	Combination C: ZERO1 = DATA4, ZERO2 = DATA1–3								
11	Combination D: ZERO1 = DATA1, ZERO2 = DATA2–4								
ZREV	Zero flag polarity selection								
	This bit controls the polarity of the zero flag pin. Default value: 0.								
	ZREV	Zero flag polarity selection							
	0	High for zero detect (default)							
1	Low for zero detect								

Table 19. Registers 71-79 (Hex 47-49, 4A-4F)

DEC	HEX	B7	B6	B5	B4	B3	B2	B1	B0
71	47	RSV	RSV	RSV	RSV	RSV	RSV	RSV	RSV
72	48	ATDA17	ATDA16	ATDA15	ATDA14	ATDA13	ATDA12	ATDA11	ATDA10
73	49	ATDA27	ATDA26	ATDA25	ATDA24	ATDA23	ATDA22	ATDA21	ATDA20
74	4A	ATDA37	ATDA36	ATDA35	ATDA34	ATDA33	ATDA32	ATDA31	ATDA30
75	4B	ATDA47	ATDA46	ATDA45	ATDA44	ATDA43	ATDA42	ATDA41	ATDA40
76	4C	ATDA57	ATDA56	ATDA55	ATDA54	ATDA53	ATDA52	ATDA51	ATDA50
77	4D	ATDA67	ATDA66	ATDA65	ATDA64	ATDA63	ATDA62	ATDA61	ATDA60
78	4E	ATDA77	ATDA76	ATDA75	ATDA74	ATDA73	ATDA72	ATDA71	ATDA70
79	4F	ATDA87	ATDA86	ATDA85	ATDA84	ATDA83	ATDA82	ATDA81	ATDA80

RSV	Reserved Reserved; do not use.
ATDAx[7:0]	<p>Digital attenuation level setting</p> <p>Where $x = 1$ to 8, corresponding to the DAC output (V_{OUTx}).</p> <p>Each DAC output (V_{OUT1} through V_{OUT8}) has a digital attenuation function. The attenuation level can be set from 0 dB to R dB, in S-dB steps. Changes in attenuator levels are made by incrementing or decrementing one step (S dB) for every $8/f_s$ time interval until the programmed attenuator setting is reached. Alternatively, the attenuation level can be set to infinite attenuation (or mute). R (Range) and S (Step) is –63 and 0.5 for DAMS = 0 and –100 and 1.0 for DAMS = 1, respectively. The DAMS bit is defined in Register 70 (46h). Table 20 shows attenuation levels for various settings.</p> <p>The attenuation level for each channel can be set individually using the following formula: Attenuation level (dB) = $S \times (ATDAx[7:0]_{DEC} - 255)$ where $ATDAx[7:0]_{DEC} = 0$ through 255.</p> <p>For $ATDAx[7:0]_{DEC} = 0$ through 128 with DAMS = 0 or 0 through 154 with DAMS = 1, attenuation is set to infinite attenuation (mute). Default value: 1111 1111.</p>

Table 20. Attenuation Levels for Various Settings

ATDAx[7:0]		ATTENUATION LEVEL SETTING	
BINARY	DECIMAL	DAMS = 0	DAMS = 1
1111 1111	255	0 dB, no attenuation (default)	0 dB, no attenuation (default)
1111 1110	254	–0.5 dB	–1 dB
1111 1101	253	–1.0 dB	–2 dB
...
1001 1100	156	–45.9 dB	–99 dB
1001 1011	155	–50.0 dB	–100 dB
1001 1010	154	–50.5 dB	Mute
...
1000 0010	130	–62.5 dB	Mute
1000 0001	129	–63.0 dB	Mute
0000 0000	128	Mute	Mute
...
0000 0000	0	Mute	Mute

8 Application and Implementation

NOTE

Information in the following applications sections is not part of the TI component specification, and TI does not warrant its accuracy or completeness. TI's customers are responsible for determining suitability of components for their purposes. Customers should validate and test their design implementation to confirm system functionality.

8.1 Application Information

8.1.1 Lowpass Filter and Differential-to-Single-Ended Converter for DAC Outputs

$\Delta\Sigma$ DACs use noise-shaping techniques to improve in-band signal-to-noise ratio (SNR) performance at the expense of generating increased out-of-band noise above the Nyquist frequency, or $f_s/2$. The out-of-band noise must be lowpass filtered in order to provide optimal converter performance. This filtering is accomplished by a combination of on-chip and external lowpass filters.

Figure 39 and Figure 40 show the recommended external differential-to-single-ended converter with lowpass active filter circuits for AC-coupled and DC-coupled applications. These circuits are second-order Butterworth filters using a multiple feedback (MFB) circuit arrangement that reduces sensitivity to passive component variations over frequency and temperature. For more information regarding MFB active filter designs, please refer to Applications Bulletin [SBAA055](#), *Dynamic Performance Testing of Digital Audio D/A Converters*, available from the TI web site (www.ti.com) or the local Texas Instruments' sales office.

Because the overall system performance is defined by the quality of the DACs and the associated analog output circuitry, high-quality audio op amps are recommended for the active filters. Texas Instruments' [OPA2134](#), [OPA2353](#), and [NE5532A](#) dual op amps are shown in Figure 39 and Figure 40, and are recommended for use with the PCM1690.

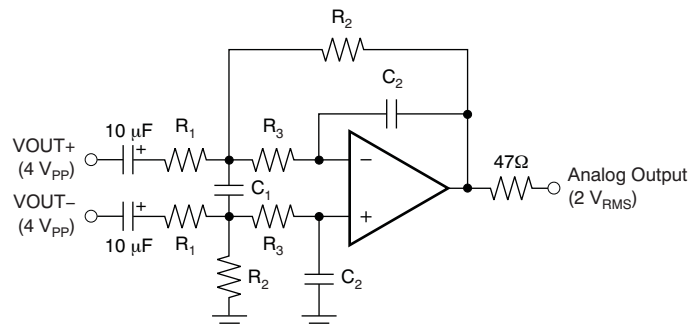

NOTE: Amplifier is an NE5532A x1/2 or OPA2134 x1/2; $R_1 = 7.5\text{-k}\Omega$; $R_2 = 5.6\text{-k}\Omega$; $R_3 = 360\text{-}\Omega$; $C_1 = 3300\text{-pF}$; $C_2 = 680\text{-pF}$; Gain = 0.747; $f_{-3\text{ dB}} = 53\text{ kHz}$.

Figure 39. AC-Coupled, Post-LPF and Differential to Single-Ended Buffer

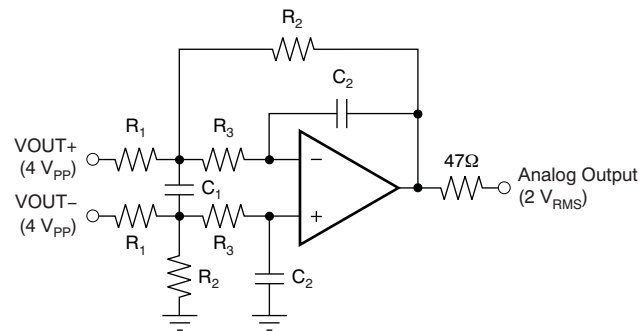
Application Information (continued)

NOTE: Amplifier is an NE5532A x1/2 or OPA2134 x1/2; $R_1 = 15\text{-k}\Omega$; $R_2 = 11\text{-k}\Omega$; $R_3 = 820\text{-}\Omega$; $C_1 = 1500\text{-pF}$; $C_2 = 330\text{-pF}$; Gain = 0.733; $f_{-3\text{ dB}} = 54\text{ kHz}$.

Figure 40. DC-Coupled, Post-LPF and Differential to Single-Ended Buffer

8.2 Typical Application

A basic connection diagram is shown in [Figure 41](#), with the necessary power-supply bypassing and decoupling components. Texas Instruments' [PLL170X](#) is used to generate the system clock input at SCKI, as well as to generate the clock for the audio signal processor. The use of series resistors ($22\ \Omega$ to $100\ \Omega$) are recommended for SCKI, LRCK, BCK, DIN1, DIN2, DIN3, and DIN4 for electromagnetic interference (EMI) reduction.

Typical Application (continued)

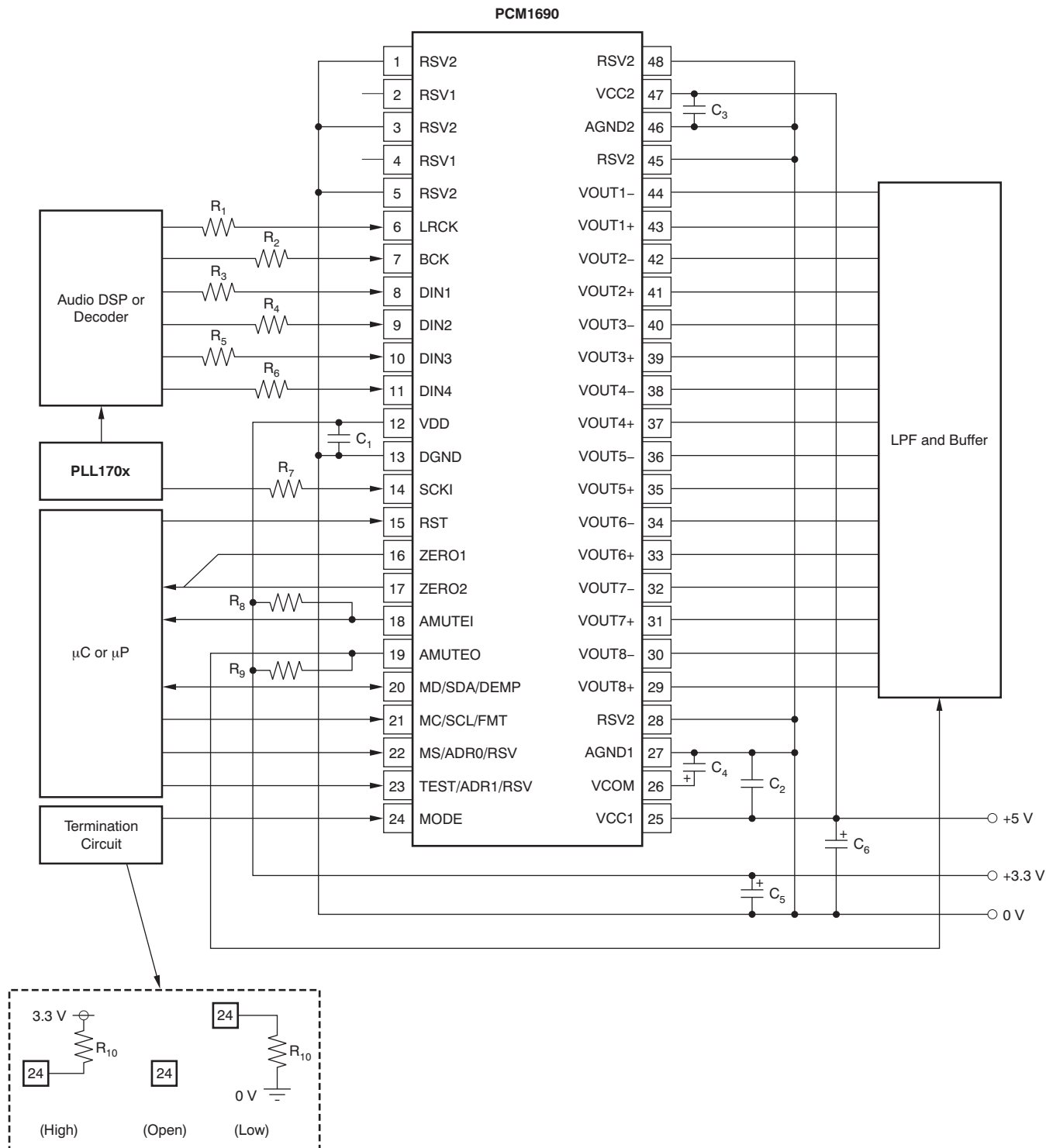

NOTE: C₁ through C₃ are 1-μF ceramic capacitors. C₄ through C₆ are 10-μF electrolytic capacitors. R₁ through R₇ are 22-Ω to 100-Ω resistors. R₈ and R₉ are resistors appropriate for pull-up. R₁₀ is less than 10 kΩ.

Figure 41. Basic Connection Diagram

Typical Application (continued)

8.2.1 Design Requirements

- Control: Hardware, I²C, or SPI
- Audio Input: PCM Serial data, TDM, or DSP
- Audio Output: $(1.6 \times VCC1)$ V_{pp} analog audio biased to $(0.5 \times VCC1)$ V
- Master Clock: PLL170X IC

8.2.2 Detailed Design Procedure

8.2.2.1 Hardware Control Method

There are 3 ways to control the PCM1690, hardware control, SPI, or I2C. Hardware control will provide a limited access to control features available in the PCM1690 but can be implemented with pull up and pull downs, or with GPIO of a microcontroller. Control via SPI or I2C will provide access to all control registers and features but will require a digital device that can implement SPI or I2C.

8.2.2.2 Audio Input

For Audio Input there are 3 options, PCM serial data, TDM, or DSP. All three will support the same quality of audio data, but having these 3 options to match the audio sources available outputs allows for greater flexibility. This selection is made by configuring the MODE pin which is detailed in [Table 6](#) and shown in Pin Functions.

8.2.2.3 Audio Output

The output of the PCM1690 will produce a differential $(1.6 \times VCC1)$ V_{pp} signal at full scale into a 5-kΩ load, that must be filtered before being sent to an amplifier. Outputs Vout1 through Vout 8 will be biased at $(0.5 \times VCC1)$ V.

8.2.2.4 Master Clock

The master clock can come from wither a dedicated IC such as the PLL170X series, a crystal or the audio source IC. What is important is that the audio source and the PCM1690 are driven from the same source so that the audio clocks will be synchronous.

8.2.3 Application Curve

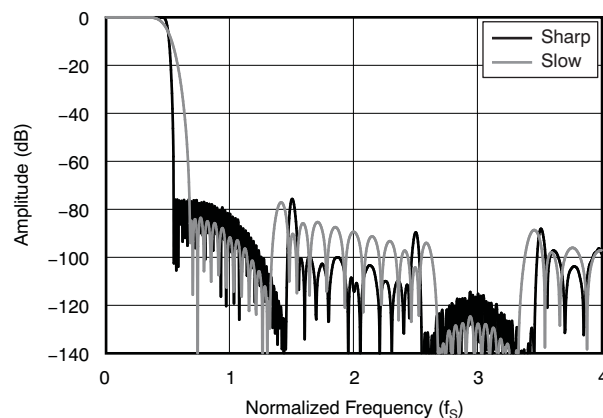

Figure 42. Frequency Response (Single Rate)

9 Power Supply Recommendations

The PCM1690 requires 5 V for the analog supply and 3.3 V for the digital supply. The 5-V supply is used to power the DAC analog and output filter circuitry, and the 3.3-V supply is used to power the digital filter and serial interface circuitry. For best performance, it is recommended to use a linear regulator with the 5-V and 3.3-V supplies.

Five capacitors are required for supply bypassing (see Figure 41). These capacitors must be located as close as possible to the PCM1690 package. The 10- μ F capacitors are aluminum electrolytic, while the three 1- μ F capacitors are ceramic.

10 Layout

10.1 Layout Guidelines

A typical printed-circuit-board (PCB) layout for the PCM1690 is shown in Figure 43. A ground plane is recommended, with the analog and digital sections being isolated from one another using a split or cut in the circuit board. The PCM1690 must be oriented with the digital I/O pins facing the ground plane split/cut to allow for short, direct connections to the digital audio interface and control signals originating from the digital section of the board.

Separate power supplies are recommended for the digital and analog sections of the board. This configuration prevents the switching noise present on the digital supply from contaminating the analog power supply and degrading the dynamic performance of the PCM1690.

10.2 Layout Example

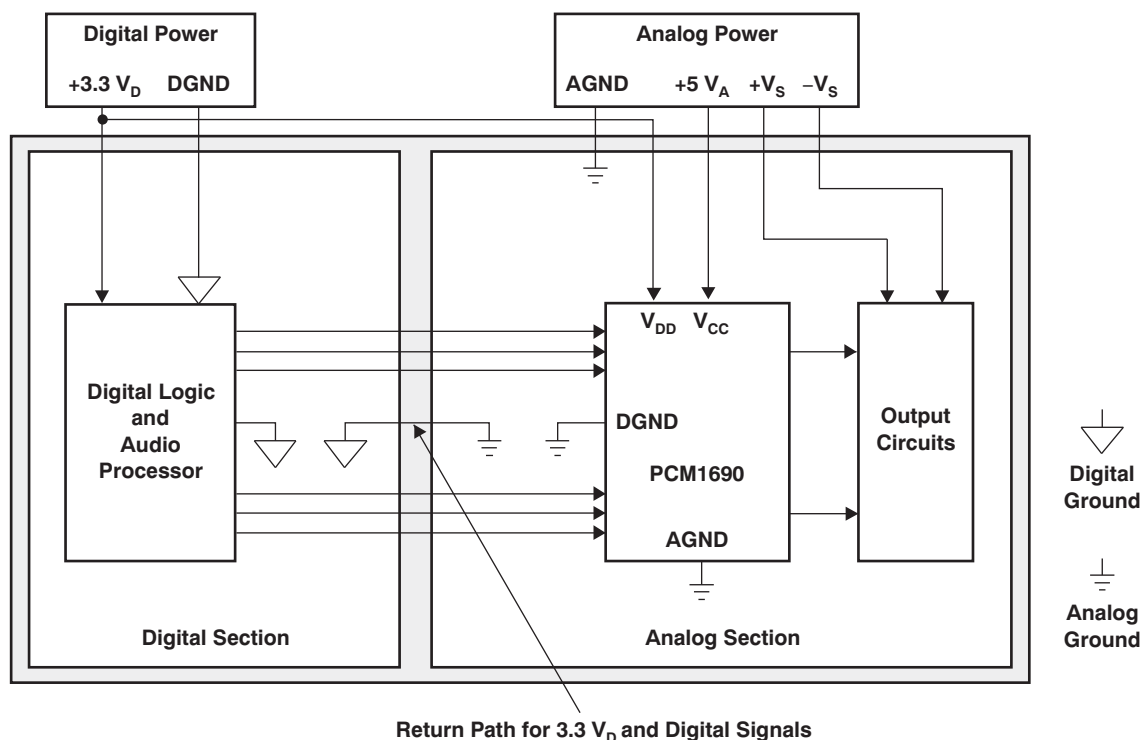

Figure 43. Recommended PCB Layout

11 Device and Documentation Support

11.1 Device Support

11.1.1 Development Support

For the PCM1690 application support, see the following:

- SoundPlus(TM) High Performance Audio Operational Amplifiers, [OPA2134](#)
- 3.3 V Dual PLL Multi-Clock Generator, [PLL170X](#)
- Dual Low-Noise Operational Amplifier, [NE5532A](#)
- High-Speed, Single-Supply, Rail-to-Rail Operational Amplifiers MicroAmplifier(TM) Series, [OPA2353](#)

11.2 Documentation Support

11.2.1 Related Documentation

For related documentation, see the following:

Dynamic Performance Testing of Digital Audio D/A Converters, [SBAA055](#)

11.3 Community Resources

The following links connect to TI community resources. Linked contents are provided "AS IS" by the respective contributors. They do not constitute TI specifications and do not necessarily reflect TI's views; see TI's [Terms of Use](#).

TI E2E™ Online Community *TI's Engineer-to-Engineer (E2E) Community*. Created to foster collaboration among engineers. At e2e.ti.com, you can ask questions, share knowledge, explore ideas and help solve problems with fellow engineers.

Design Support *TI's Design Support* Quickly find helpful E2E forums along with design support tools and contact information for technical support.

11.4 Trademarks

E2E is a trademark of Texas Instruments.

Blu-ray is a trademark of Blu-ray Disk Association.

I²S is a trademark of NXP Semiconductors.

All other trademarks are the property of their respective owners.

11.5 Electrostatic Discharge Caution



These devices have limited built-in ESD protection. The leads should be shorted together or the device placed in conductive foam during storage or handling to prevent electrostatic damage to the MOS gates.

11.6 Glossary

[SLYZ022](#) — *TI Glossary*.

This glossary lists and explains terms, acronyms, and definitions.

12 Mechanical, Packaging, and Orderable Information

The following pages include mechanical, packaging, and orderable information. This information is the most current data available for the designated devices. This data is subject to change without notice and revision of this document. For browser-based versions of this data sheet, refer to the left-hand navigation.

PACKAGING INFORMATION

Orderable Device	Status (1)	Package Type	Package Drawing	Pins	Package Qty	Eco Plan (2)	Lead/Ball Finish (6)	MSL Peak Temp (3)	Op Temp (°C)	Device Marking (4/5)	Samples
PCM1690DCA	ACTIVE	HTSSOP	DCA	48	40	Green (RoHS & no Sb/Br)	CU NIPDAU	Level-3-260C-168 HR	-40 to 85	PCM1690	Samples
PCM1690DCAR	ACTIVE	HTSSOP	DCA	48	2000	Green (RoHS & no Sb/Br)	CU NIPDAU	Level-3-260C-168 HR	-40 to 85	PCM1690	Samples

(1) The marketing status values are defined as follows:

ACTIVE: Product device recommended for new designs.

LIFEBUY: TI has announced that the device will be discontinued, and a lifetime-buy period is in effect.

NRND: Not recommended for new designs. Device is in production to support existing customers, but TI does not recommend using this part in a new design.

PREVIEW: Device has been announced but is not in production. Samples may or may not be available.

OBSELETE: TI has discontinued the production of the device.

(2) Eco Plan - The planned eco-friendly classification: Pb-Free (RoHS), Pb-Free (RoHS Exempt), or Green (RoHS & no Sb/Br) - please check <http://www.ti.com/productcontent> for the latest availability information and additional product content details.

TBD: The Pb-Free/Green conversion plan has not been defined.

Pb-Free (RoHS): TI's terms "Lead-Free" or "Pb-Free" mean semiconductor products that are compatible with the current RoHS requirements for all 6 substances, including the requirement that lead not exceed 0.1% by weight in homogeneous materials. Where designed to be soldered at high temperatures, TI Pb-Free products are suitable for use in specified lead-free processes.

Pb-Free (RoHS Exempt): This component has a RoHS exemption for either 1) lead-based flip-chip solder bumps used between the die and package, or 2) lead-based die adhesive used between the die and leadframe. The component is otherwise considered Pb-Free (RoHS compatible) as defined above.

Green (RoHS & no Sb/Br): TI defines "Green" to mean Pb-Free (RoHS compatible), and free of Bromine (Br) and Antimony (Sb) based flame retardants (Br or Sb do not exceed 0.1% by weight in homogeneous material)

(3) MSL, Peak Temp. - The Moisture Sensitivity Level rating according to the JEDEC industry standard classifications, and peak solder temperature.

(4) There may be additional marking, which relates to the logo, the lot trace code information, or the environmental category on the device.

(5) Multiple Device Markings will be inside parentheses. Only one Device Marking contained in parentheses and separated by a "~" will appear on a device. If a line is indented then it is a continuation of the previous line and the two combined represent the entire Device Marking for that device.

(6) Lead/Ball Finish - Orderable Devices may have multiple material finish options. Finish options are separated by a vertical ruled line. Lead/Ball Finish values may wrap to two lines if the finish value exceeds the maximum column width.

Important Information and Disclaimer: The information provided on this page represents TI's knowledge and belief as of the date that it is provided. TI bases its knowledge and belief on information provided by third parties, and makes no representation or warranty as to the accuracy of such information. Efforts are underway to better integrate information from third parties. TI has taken and continues to take reasonable steps to provide representative and accurate information but may not have conducted destructive testing or chemical analysis on incoming materials and chemicals. TI and TI suppliers consider certain information to be proprietary, and thus CAS numbers and other limited information may not be available for release.

In no event shall TI's liability arising out of such information exceed the total purchase price of the TI part(s) at issue in this document sold by TI to Customer on an annual basis.

OTHER QUALIFIED VERSIONS OF PCM1690 :

- Automotive: [PCM1690-Q1](#)

NOTE: Qualified Version Definitions:

- Automotive - Q100 devices qualified for high-reliability automotive applications targeting zero defects

TAPE AND REEL INFORMATION

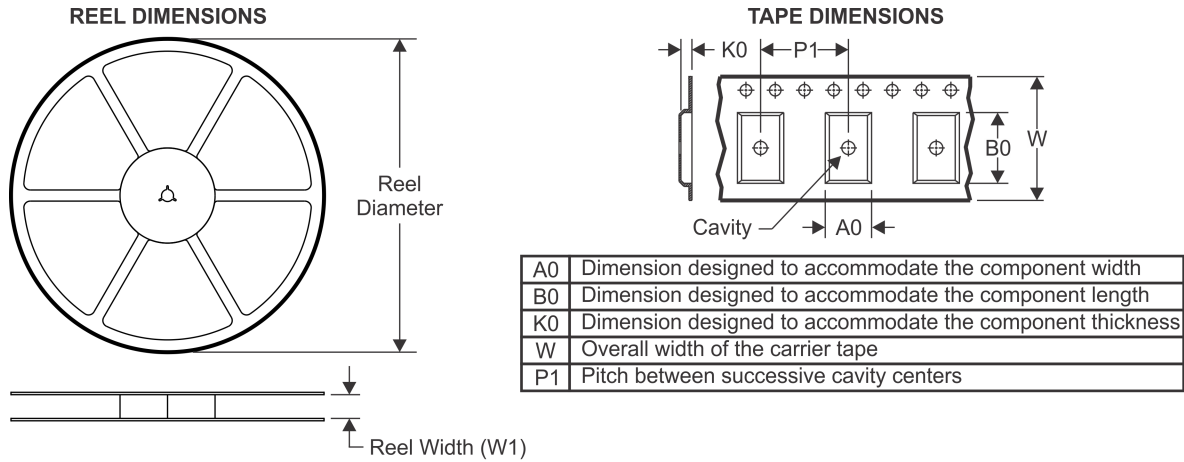

QUADRANT ASSIGNMENTS FOR PIN 1 ORIENTATION IN TAPE

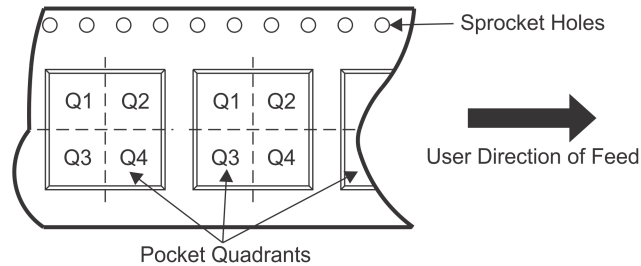

*All dimensions are nominal

Device	Package Type	Package Drawing	Pins	SPQ	Reel Diameter (mm)	Reel Width W1 (mm)	A0 (mm)	B0 (mm)	K0 (mm)	P1 (mm)	W (mm)	Pin1 Quadrant
PCM1690DCAR	HTSSOP	DCA	48	2000	330.0	24.4	8.6	15.8	1.8	12.0	24.0	Q1

TAPE AND REEL BOX DIMENSIONS



*All dimensions are nominal

Device	Package Type	Package Drawing	Pins	SPQ	Length (mm)	Width (mm)	Height (mm)
PCM1690DCAR	HTSSOP	DCA	48	2000	367.0	367.0	45.0

MECHANICAL DATA

DCA (R-PDSO-G48)

PowerPAD™ PLASTIC SMALL-OUTLINE

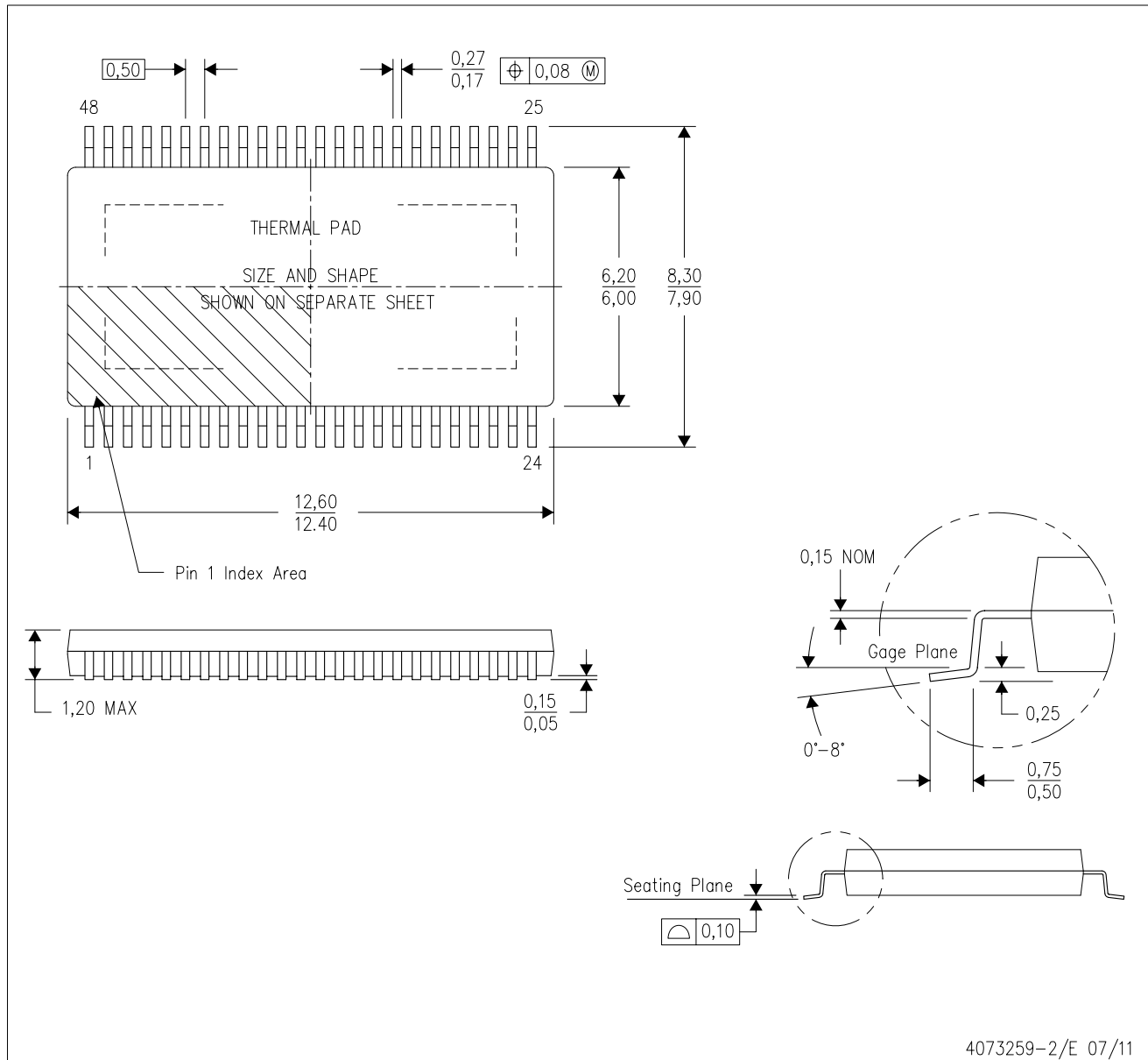

- NOTES:
- All linear dimensions are in millimeters. Dimensioning and tolerancing per ASME Y14.5M-1994.
 - This drawing is subject to change without notice.
 - Body dimensions do not include mold flash or protrusion not to exceed 0,15.
 - This package is designed to be soldered to a thermal pad on the board. Refer to Technical Brief, PowerPad Thermally Enhanced Package, Texas Instruments Literature No. SLMA002 for information regarding recommended board layout. This document is available at www.ti.com <<http://www.ti.com>>.
 - See the additional figure in the Product Data Sheet for details regarding the exposed thermal pad features and dimensions.
 - Falls within JEDEC MO-153

PowerPAD is a trademark of Texas Instruments.

THERMAL PAD MECHANICAL DATA

DCA (R-PDSO-G48)

PowerPAD™ PLASTIC SMALL OUTLINE

THERMAL INFORMATION

This PowerPAD™ package incorporates an exposed thermal pad that is designed to be attached to a printed circuit board (PCB). The thermal pad must be soldered directly to the PCB. After soldering, the PCB can be used as a heatsink. In addition, through the use of thermal vias, the thermal pad can be attached directly to the appropriate copper plane shown in the electrical schematic for the device, or alternatively, can be attached to a special heatsink structure designed into the PCB. This design optimizes the heat transfer from the integrated circuit (IC).

For additional information on the PowerPAD package and how to take advantage of its heat dissipating abilities, refer to Technical Brief, PowerPAD Thermally Enhanced Package, Texas Instruments Literature No. SLMA002 and Application Brief, PowerPAD Made Easy, Texas Instruments Literature No. SLMA004. Both documents are available at www.ti.com.

The exposed thermal pad dimensions for this package are shown in the following illustration.

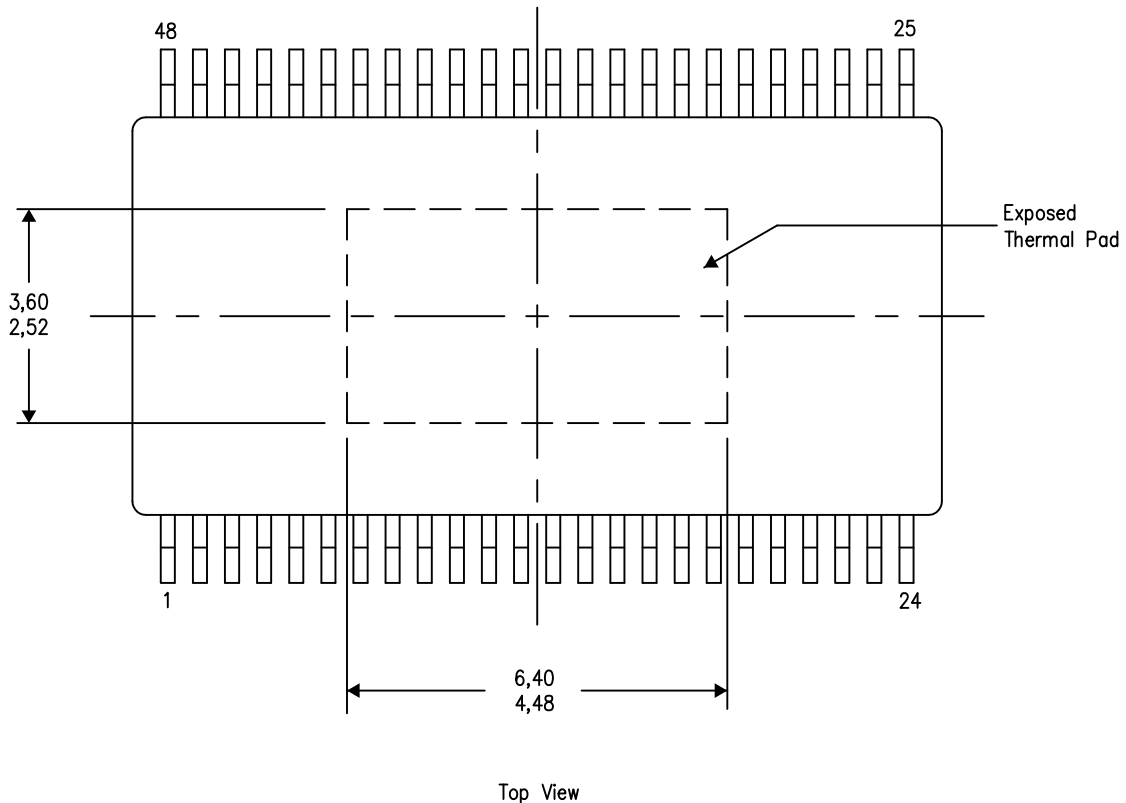

Exposed Thermal Pad Dimensions

4206320-4/S 11/14

NOTE: A. All linear dimensions are in millimeters

PowerPAD is a trademark of Texas Instruments.

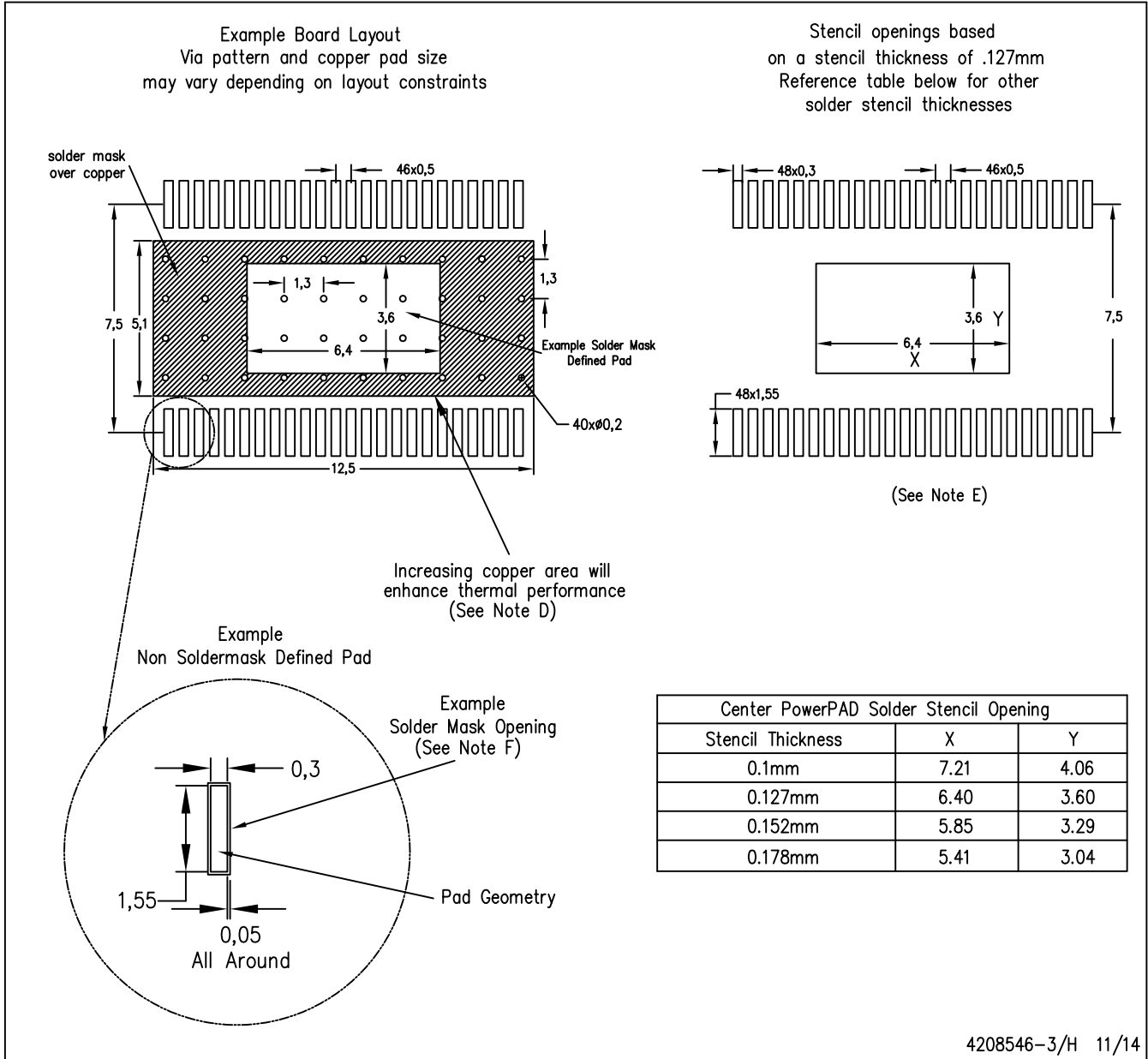

- NOTES:
- A. All linear dimensions are in millimeters.
 - B. This drawing is subject to change without notice.
 - C. Customers should place a note on the circuit board fabrication drawing not to alter the center solder mask defined pad.
 - D. This package is designed to be soldered to a thermal pad on the board. Refer to Technical Brief, PowerPAD Thermally Enhanced Package, Texas Instruments Literature No. SLMA002, SLMA004, and also the Product Data Sheets for specific thermal information, via requirements, and recommended board layout. These documents are available at www.ti.com <<http://www.ti.com>>. Publication IPC-7351 is recommended for alternate designs.
 - E. Laser cutting apertures with trapezoidal walls and also rounding corners will offer better paste release. Customers should contact their board assembly site for stencil design recommendations. Example stencil design based on a 50% volumetric metal load solder paste. Refer to IPC-7525 for other stencil recommendations.
 - F. Customers should contact their board fabrication site for solder mask tolerances between and around signal pads.

IMPORTANT NOTICE

Texas Instruments Incorporated and its subsidiaries (TI) reserve the right to make corrections, enhancements, improvements and other changes to its semiconductor products and services per JESD46, latest issue, and to discontinue any product or service per JESD48, latest issue. Buyers should obtain the latest relevant information before placing orders and should verify that such information is current and complete. All semiconductor products (also referred to herein as "components") are sold subject to TI's terms and conditions of sale supplied at the time of order acknowledgment.

TI warrants performance of its components to the specifications applicable at the time of sale, in accordance with the warranty in TI's terms and conditions of sale of semiconductor products. Testing and other quality control techniques are used to the extent TI deems necessary to support this warranty. Except where mandated by applicable law, testing of all parameters of each component is not necessarily performed.

TI assumes no liability for applications assistance or the design of Buyers' products. Buyers are responsible for their products and applications using TI components. To minimize the risks associated with Buyers' products and applications, Buyers should provide adequate design and operating safeguards.

TI does not warrant or represent that any license, either express or implied, is granted under any patent right, copyright, mask work right, or other intellectual property right relating to any combination, machine, or process in which TI components or services are used. Information published by TI regarding third-party products or services does not constitute a license to use such products or services or a warranty or endorsement thereof. Use of such information may require a license from a third party under the patents or other intellectual property of the third party, or a license from TI under the patents or other intellectual property of TI.

Reproduction of significant portions of TI information in TI data books or data sheets is permissible only if reproduction is without alteration and is accompanied by all associated warranties, conditions, limitations, and notices. TI is not responsible or liable for such altered documentation. Information of third parties may be subject to additional restrictions.

Resale of TI components or services with statements different from or beyond the parameters stated by TI for that component or service voids all express and any implied warranties for the associated TI component or service and is an unfair and deceptive business practice. TI is not responsible or liable for any such statements.

Buyer acknowledges and agrees that it is solely responsible for compliance with all legal, regulatory and safety-related requirements concerning its products, and any use of TI components in its applications, notwithstanding any applications-related information or support that may be provided by TI. Buyer represents and agrees that it has all the necessary expertise to create and implement safeguards which anticipate dangerous consequences of failures, monitor failures and their consequences, lessen the likelihood of failures that might cause harm and take appropriate remedial actions. Buyer will fully indemnify TI and its representatives against any damages arising out of the use of any TI components in safety-critical applications.

In some cases, TI components may be promoted specifically to facilitate safety-related applications. With such components, TI's goal is to help enable customers to design and create their own end-product solutions that meet applicable functional safety standards and requirements. Nonetheless, such components are subject to these terms.

No TI components are authorized for use in FDA Class III (or similar life-critical medical equipment) unless authorized officers of the parties have executed a special agreement specifically governing such use.

Only those TI components which TI has specifically designated as military grade or "enhanced plastic" are designed and intended for use in military/aerospace applications or environments. Buyer acknowledges and agrees that any military or aerospace use of TI components which have **not** been so designated is solely at the Buyer's risk, and that Buyer is solely responsible for compliance with all legal and regulatory requirements in connection with such use.

TI has specifically designated certain components as meeting ISO/TS16949 requirements, mainly for automotive use. In any case of use of non-designated products, TI will not be responsible for any failure to meet ISO/TS16949.

Products

Audio	www.ti.com/audio
Amplifiers	amplifier.ti.com
Data Converters	dataconverter.ti.com
DLP® Products	www.dlp.com
DSP	dsp.ti.com
Clocks and Timers	www.ti.com/clocks
Interface	interface.ti.com
Logic	logic.ti.com
Power Mgmt	power.ti.com
Microcontrollers	microcontroller.ti.com
RFID	www.ti-rfid.com
OMAP Applications Processors	www.ti.com/omap
Wireless Connectivity	www.ti.com/wirelessconnectivity

Applications

Automotive and Transportation	www.ti.com/automotive
Communications and Telecom	www.ti.com/communications
Computers and Peripherals	www.ti.com/computers
Consumer Electronics	www.ti.com/consumer-apps
Energy and Lighting	www.ti.com/energy
Industrial	www.ti.com/industrial
Medical	www.ti.com/medical
Security	www.ti.com/security
Space, Avionics and Defense	www.ti.com/space-avionics-defense
Video and Imaging	www.ti.com/video

TI E2E Community

e2e.ti.com