

PCA9574

8-bit I²C-bus and SMBus, level translating, low voltage GPIO with reset and interrupt

Rev. 6.0 — 31 May 2023

Product data sheet



1 General description

The PCA9574 is a CMOS device that provides 8 bits of General Purpose parallel Input/Output (GPIO) expansion in low voltage processor and handheld battery powered mobile applications and was developed to enhance the NXP family of I²C-bus I/O expanders. The improvements include lower supply current, lower operating voltage of 1.1 V to 3.6 V, dual and separate supply rails to allow voltage level translation anywhere between 1.1 V and 3.6 V, 400 kHz clock frequency, and smaller packaging. Any of the eight I/O ports can be configured as an input or output independent of each other and default on start-up to inputs. I/O expanders provide a simple solution when additional I/Os are needed while keeping interconnections to a minimum; for example in battery powered mobile applications and clamshell devices for interfacing to sensors, push buttons, keypad, etc. In addition to providing a flexible set of GPIOs, it simplifies interconnection of a processor running at one voltage level to I/O devices operating at a different (usually higher) voltage level. PCA9574 has built-in level shifting feature that makes these devices extremely flexible in mixed signal environments where communication between incompatible I/Os is required. The core of PCA9574 can operate at a voltage as low as 1.1 V while the I/O bank can operate in the range 1.1 V to 3.6 V. Bus-hold with programmable on-chip pull-up or pull-down feature for I/Os is also provided.

The system controller can enable the I/Os as either inputs or outputs by writing to the I/O configuration register bits. The data for each input or output is kept in the corresponding Input or Output register. The polarity of the read register can be inverted with the Polarity inversion register (active HIGH or active LOW operation). Either a bus-hold function or pull-up/pull-down feature can be selected by programming corresponding registers. The bus-hold provides a valid logic level when the I/O bus is not actively driven. When bus-hold feature is not selected, the I/O ports can be configured to have pull-up or pull-down by programming the pull-up/pull-down configuration register.

An open-drain interrupt output pin (\overline{INT}) allows monitoring of the input pins and is asserted each time a change occurs on an input port unless that port is masked (default = masked). A 'GPIO All Call' command allows programming multiple PCA9574s at the same time even if they have different individual I²C-bus addresses. This allows optimal code programming when more than one device needs to be programmed with the same instruction or if all outputs need to be turned on or off at the same time. The internal Power-On Reset (POR) or hardware reset pin (RESET) initializes the eight I/Os as inputs, sets the registers to their default values and initializes the device state machine. The I/O bank is held in its default state when the logic supply (V_{DD}) is off.

One address select pin allows up to two PCA9574 devices to be connected with two different addresses on the same I²C-bus.

The PCA9574 is available in TSSOP16 and HVQFN16 packages and is specified over the -40 °C to +85 °C industrial temperature range.

2 Features and benefits

- 400 kHz I²C-bus serial interface



- Compliant with I²C-bus Standard-mode (100 kHz)
- Separate supply rails for core logic and I/O bank provides voltage level shifting
- 1.1 V to 3.6 V operation with level shifting feature
- Very low standby current: < 1 μA
- 8 configurable I/O pins that default to inputs at power-up
- Outputs:
 - Totem pole: 1 mA source and 3 mA sink
 - Independently programmable 100 kΩ pull-up or pull-down for each I/O pin
 - Open-drain active LOW interrupt (INT) output pin allows monitoring of logic level change of pins programmed as inputs
- Inputs:
 - Programmable bus hold provides valid logic level when inputs are not actively driven
 - Programmable Interrupt Mask Control for input pins that do not require an interrupt when their states change or to prevent spurious interrupts default to mask at power-up
 - Polarity inversion register allows inversion of the polarity of the I/O pins when read
- Active LOW reset (RESET) input pin resets device to power-up default state
- GPIO All Call address allows programming of more than one device at the same time with the same parameters
- 2 programmable target addresses using 1 address pin
- -40 °C to +85 °C operation
- ESD protection exceeds 7000 V HBM per JESD22-A114 and 1000 V CDM per JESD22-C101
- Latch-up testing is done to JEDEC Standard JESD78 which exceeds 100 mA
- Packages offered: TSSOP16 and HVQFN16

3 Applications

- Cell phones
- Media players
- Multi voltage environments
- Battery operated mobile gadgets
- Motherboards
- Servers
- RAID systems
- Industrial control
- Medical equipment
- PLCs
- Gaming machines
- Instrumentation and test measurement

4 Ordering information

Table 1. Ordering information

Type number	Topside marking	Package		
		Name	Description	Version
PCA9574PW	PCA9574	TSSOP16	plastic thin shrink small outline package; 16 leads; body width 4.4 mm	SOT403-1
PCA9574BS	P74	HVQFN16	plastic thermal enhanced very thin quad flat package; no leads; 16 terminals; body 3 × 3 × 0.85 mm	SOT758-1

4.1 Ordering options

Table 2. Ordering options

Type number	Orderable part number	Package	Packing method	Minimum order quantity	Temperature range
PCA9574PW	PCA9574PW,118	TSSOP16	Reel 13" Q1/T1 *standard mark SMD	2500	T _{amb} = -40 °C to +85 °C
PCA9574BS	PCA9574BS,118	HVQFN16	Reel 13" Q1/T1 *standard mark SMD	6000	T _{amb} = -40 °C to +85 °C

5 Block diagram

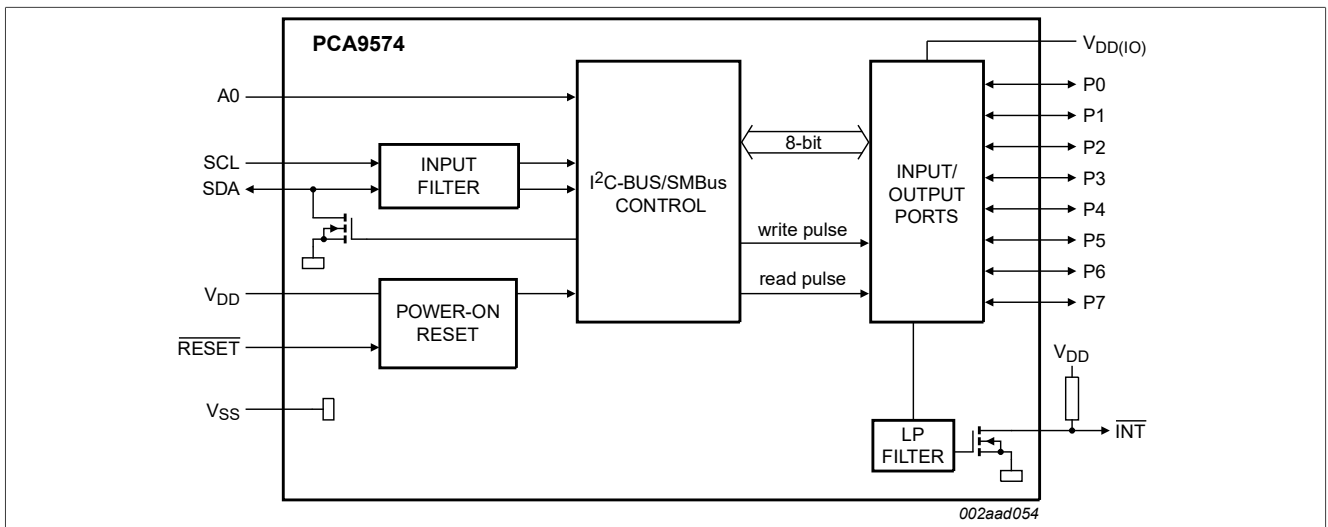

Remark: All I/Os are set to inputs at power-up and RESET.

Figure 1. Block diagram of PCA9574

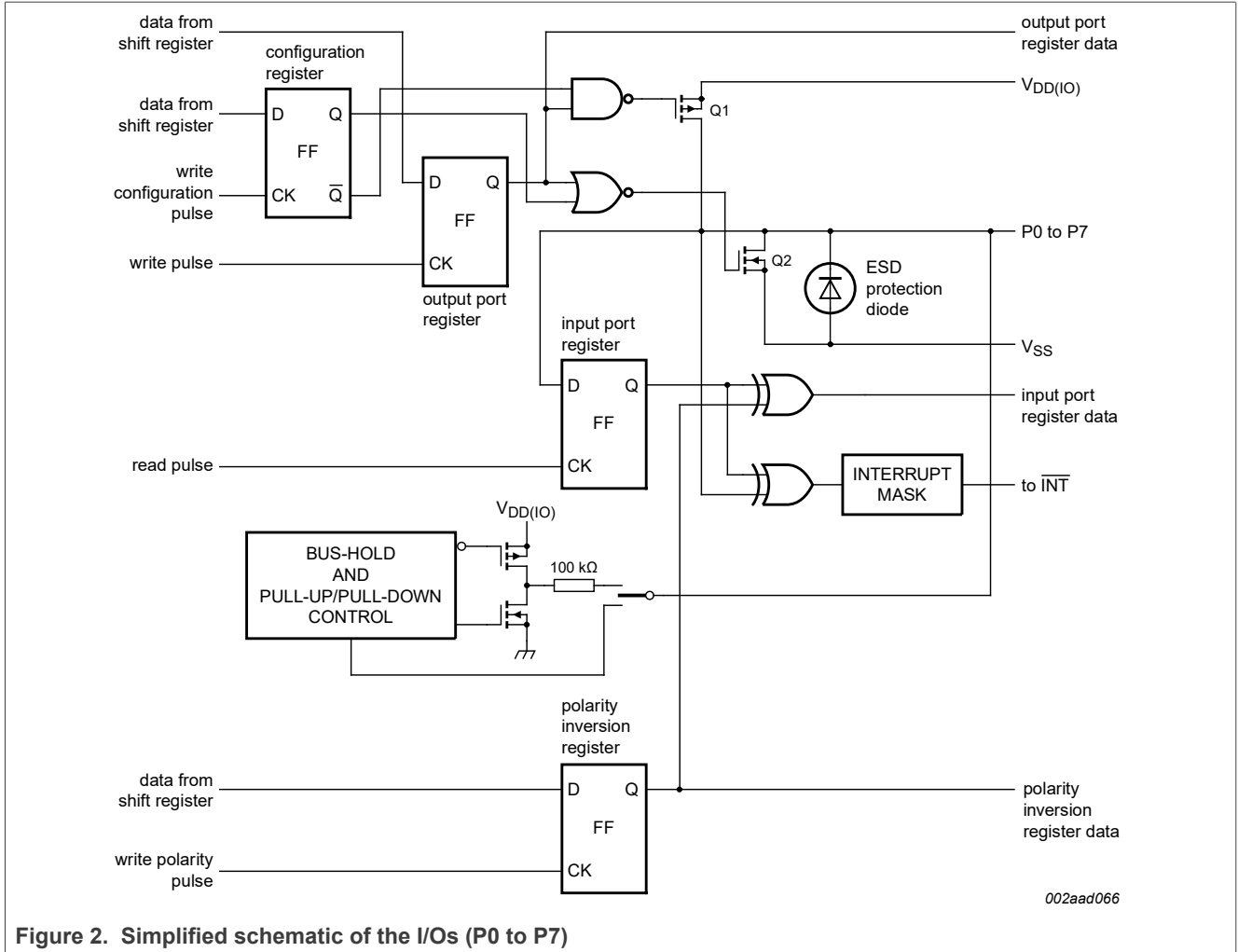

Figure 2. Simplified schematic of the I/Os (P0 to P7)

6 Pinning information

6.1 Pinning

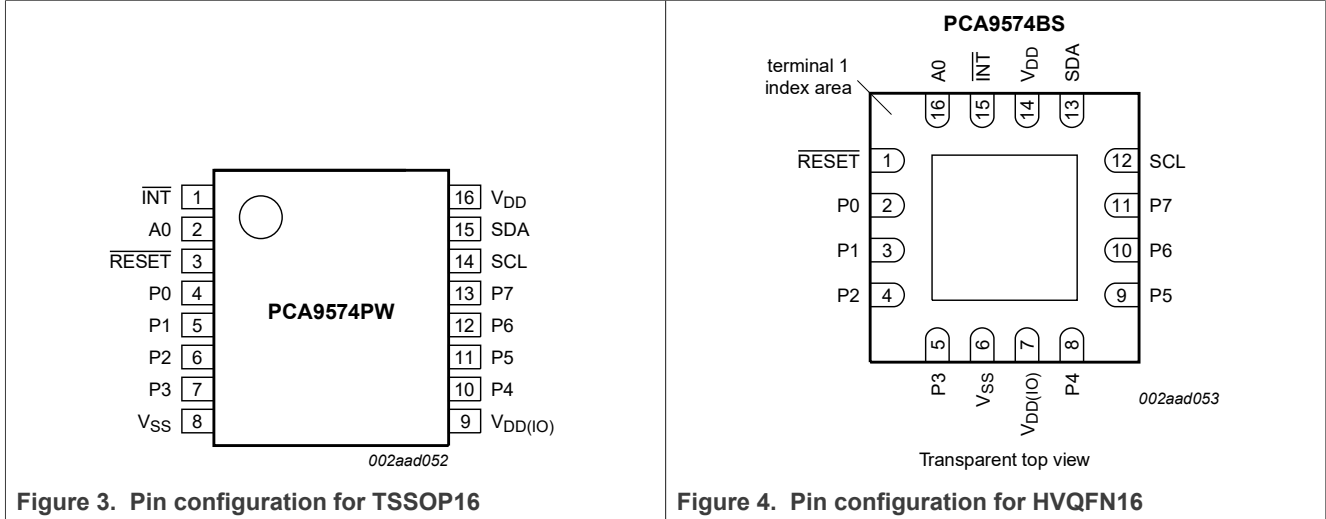

Figure 3. Pin configuration for TSSOP16

Figure 4. Pin configuration for HVQFN16

6.2 Pin description

Table 3. Pin description

Symbol	Pin		Type	Description
	TSSOP16	HVQFN16		
INT	1	15	O	active LOW interrupt output; active LOW SMBus alert output
A0	2	16	I	address input
RESET	3	1	I	active LOW reset input
P0	4	2	I/O	input/output 0
P1	5	3	I/O	input/output 1
P2	6	4	I/O	input/output 2
P3	7	5	I/O	input/output 3
V _{SS}	8	6 ^[1]	ground	supply ground
V _{DD(IO)}	9	7	power supply	I/O bank supply voltage
P4	10	8	I/O	input/output 4
P5	11	9	I/O	input/output 5
P6	12	10	I/O	input/output 6
P7	13	11	I/O	input/output 7
SCL	14	12	I	serial clock line
SDA	15	13	I/O	serial data line
V _{DD}	16	14	power supply	supply voltage

[1] HVQFN16 package die supply ground is connected to both V_{SS} pin and exposed center pad. V_{SS} pin must be connected to supply ground for proper device operation. For enhanced thermal, electrical, and board level performance, the exposed pad needs to be soldered to the board using a

corresponding thermal pad on the board and for proper heat conduction through the board, thermal vias need to be incorporated in the PCB in the thermal pad region.

7 Functional description

7.1 Device address

Following a START condition the bus controller must send the address of the target it is accessing and the operation it wants to perform (read or write). The address of the PCA9574 is shown in [Figure 5](#). Target address pin A0 chooses 1 of 2 target addresses: 40h or 42h.

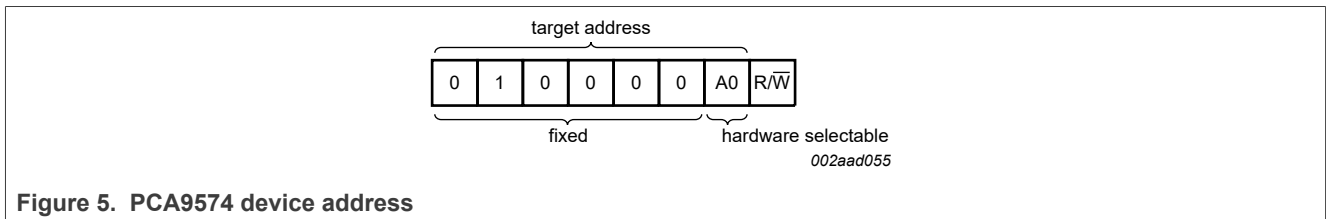

Figure 5. PCA9574 device address

The last bit of the first byte defines the operation to be performed. When set to logic 1 a read is selected, while logic 0 selects a write operation.

7.2 Command register

Following the successful acknowledgement of the target address + R/W bit, the bus controller will send a byte to the PCA9574, which will be stored in the Command register.

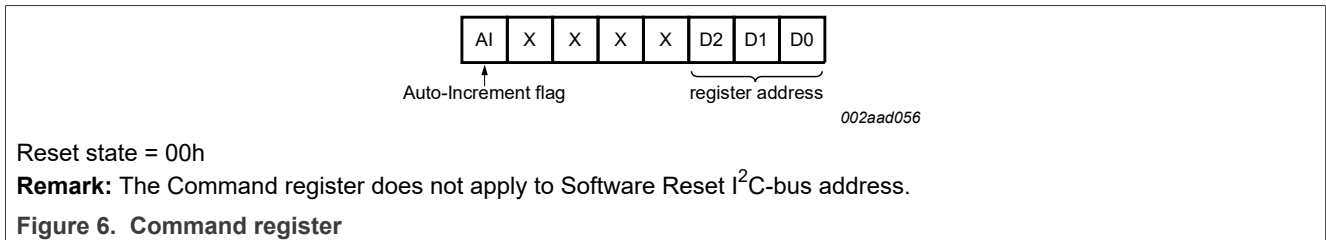

Figure 6. Command register

The lowest three bits are used as a pointer to determine which register will be accessed. Only a command register code with the three least significant bits equal to the eight allowable values as defined in [Table 4](#) will be acknowledged. Reserved or undefined command codes will not be acknowledged. At power-up, this register defaults to 00h, with the AI bit set to '0', and the lowest 3 bits set to '0'.

If the Auto-Increment flag is set (AI = 1), the three least significant bits of the Command register are automatically incremented after a read or write. This allows the user to program and/or read the eight command registers (listed in [Table 4](#)) sequentially. It will then roll over to register 00h after the last register is accessed and the selected registers will be overwritten or re-read.

If the Auto-Increment flag is cleared (AI = 0), the three least significant bits are not incremented after data is read or written, only one register will be repeatedly read or written.

7.3 Register definitions

Table 4. Register summary

Register number	D2	D1	D0	Name	Type	Function
00h	0	0	0	IN	read only	Input port register

Table 4. Register summary...continued

Register number	D2	D1	D0	Name	Type	Function
01h	0	0	1	INVRT	read/write	Polarity inversion register
02h	0	1	0	BKEN	read/write	Bus-hold enable register
03h	0	1	1	PUPD	read/write	Pull-up/pull-down selector register
04h	1	0	0	CFG	read/write	Port configuration register
05h	1	0	1	OUT	read/write	Output port register
06h	1	1	0	MSK	read/write	Interrupt mask register
07h	1	1	1	INTS	read only	Interrupt status register

7.4 Writing to port registers

Data is transmitted to the PCA9574 by sending the device address and setting the least significant bit to logic 0 (see [Figure 5](#) for device address). The command byte is sent after the address and determines which register will receive the data following the command byte. Each 8-bit register may be updated independently of the other registers.

7.5 Reading the port registers

In order to read data from the PCA9574, the bus controller must first send the PCA9574 address with the least significant bit set to a logic 0 (see [Figure 5](#) for device address). The command byte is sent after the address and determines which register will be accessed. After a restart, the device address is sent again but this time, the least significant bit is set to logic 1. Data from the register defined by the command byte will then be sent by the PCA9574. Data is clocked into the register on the falling edge of the acknowledge clock pulse. After the first byte is read, additional bytes may be read using the auto-increment feature.

7.5.1 Register 0 - Input port register

This register is read-only. It reflects the incoming logic levels of the pins, regardless of whether the pin is defined as an input or an output by the Configuration register. Writes to this register will be acknowledged but will have no effect.

The default 'X' is determined by the externally applied logic level.

Table 5. Register 0 - Input port register (address 00h) bit description

Bit	Symbol	Access	Value	Description
7	I0.7	read only	X	determined by externally applied logic level
6	I0.6	read only	X	
5	I0.5	read only	X	
4	I0.4	read only	X	
3	I0.3	read only	X	
2	I0.2	read only	X	
1	I0.1	read only	X	
0	I0.0	read only	X	

7.5.2 Register 1 - Polarity inversion register

This register allows the user to invert the polarity of the Input port register data. If a bit in this register is set (written with '1'), the corresponding Input port data is inverted. If a bit in this register is cleared (written with a '0'), the Input port data polarity is retained.

Table 6. Register 1 - Polarity inversion register (address 01h) bit description

Legend: * default value.

Bit	Symbol	Access	Value	Description
7	N0.7	R/W	0*	inverts polarity of Input port register data 0 = Input port register data retained (default value) 1 = Input port register data inverted
6	N0.6	R/W	0*	
5	N0.5	R/W	0*	
4	N0.4	R/W	0*	
3	N0.3	R/W	0*	
2	N0.2	R/W	0*	
1	N0.1	R/W	0*	
0	N0.0	R/W	0*	

7.5.3 Register 2 - Bus-hold/pull-up/pull-down enable register

Bit 0 of this register allows the user to enable/disable the bus-hold feature for the I/O pins. Setting the bit 0 to logic 1 enables bus-hold feature for the I/O bank. In this mode, the pull-up/pull-downs will be disabled. Setting the bit 0 to logic 0 disables bus-hold feature.

Bit 1 of this register allows the user to enable/disable pull-up/pull-downs on the I/O pins. Setting the bit 1 to logic 1 enables selection of pull-up/pull-down using Register 3. Setting the bit 1 to logic 0 disables pull-up/pull-downs on the I/O pins and contents of Register 3 will have no effect on the I/O.

Table 7. Register 2 - Bus-hold/pull-up/pull-down enable register (address 02h) bit description

Legend: * default value.

Bit	Symbol	Access	Value	Description
7	E0.7	R/W	X	not used
6	E0.6	R/W	X	
5	E0.5	R/W	X	
4	E0.4	R/W	X	
3	E0.3	R/W	X	
2	E0.2	R/W	X	
1	E0.1	R/W	0*	allows the user to enable/disable pull-up/pull-downs on the I/O pins 0 = disables pull-up/pull-downs on the I/O pins and contents of Register 3 will have no effect on the I/O (default value) 1 = enables selection of pull-up/pull-down using Register 3
0	E0.0	R/W	0*	allows user to enable/disable the bus-hold feature for the I/O pins 0 = disables bus-hold feature (default value) 1 = enables bus-hold feature

7.5.4 Register 3 - Pull-up/pull-down selector register

When bus-hold feature is not selected and bit 1 of Register 2 is set to logic 1, the I/O port can be configured to have pull-up or pull-down by programming the pull-up/pull-down register. Setting a bit to logic 1 will select a 100 kΩ pull-up resistor for that I/O pin. Setting a bit to logic 0 will select a 100 kΩ pull-down resistor for that I/O pin. If the bus-hold feature is enabled, writing to this register will have no effect on pull-up/pull-down selection.

Table 8. Register 3 - Pull-up/pull-down selector register (address 03h) bit description

Legend: * default value.

Bit	Symbol	Access	Value	Description
7	P0.7	R/W	1*	configures I/O port pin to have pull-up or pull-down when bus-hold feature not selected and bit 1 of Register 2 is logic 1 0 = selects a 100 kΩ pull-down resistor for that I/O pin 1 = selects a 100 kΩ pull-up resistor for that I/O pin (default value)
6	P0.6	R/W	1*	
5	P0.5	R/W	1*	
4	P0.4	R/W	1*	
3	P0.3	R/W	1*	
2	P0.2	R/W	1*	
1	P0.1	R/W	1*	
0	P0.0	R/W	1*	

7.5.5 Register 4 - Configuration register

This register configures the direction of the I/O pins. If a bit in this register is set (written with logic 1), the corresponding port pin is enabled as an input with high-impedance output driver. If a bit in this register is cleared (written with logic 0), the corresponding port pin is enabled as an output. At reset, the device's ports are inputs.

Table 9. Register 4 - Configuration register (address 04h) bit description

Legend: * default value.

Bit	Symbol	Access	Value	Description
7	C0.7	R/W	1*	configures the direction of the I/O pins 0 = corresponding port pin enabled as an output 1 = corresponding port pin configured as input (default value)
6	C0.6	R/W	1*	
5	C0.5	R/W	1*	
4	C0.4	R/W	1*	
3	C0.3	R/W	1*	
2	C0.2	R/W	1*	
1	C0.1	R/W	1*	
0	C0.0	R/W	1*	

7.5.6 Register 5 - Output port register

This register is an output-only port. It reflects the outgoing logic levels of the pins defined as outputs by Register 4. Bit values in this register have no effect on pins defined as inputs. In turn, reads from this register reflect the value that is in the flip-flop controlling the output selection, **not** the actual pin value.

Table 10. Register 5 - Output port register (address 05h) bit description

Legend: * default value.

Bit	Symbol	Access	Value	Description
7	O0.7	R/W	0*	reflects outgoing logic levels of pins defined as outputs by Register 4
6	O0.6	R/W	0*	
5	O0.5	R/W	0*	
4	O0.4	R/W	0*	
3	O0.3	R/W	0*	
2	O0.2	R/W	0*	
1	O0.1	R/W	0*	
0	O0.0	R/W	0*	

7.5.7 Register 6 - Interrupt mask register

All the bits of Interrupt mask register are set to logic 1 upon power-on or software reset, thus disabling interrupts. Interrupts may be enabled by setting corresponding mask bits to logic 0.

Table 11. Register 6 - Interrupt mask register (address 06h) bit description

Legend: * default value.

Bit	Symbol	Access	Value	Description
7	M0.7	R/W	1*	enable or disable interrupts 0 = enable interrupt 1 = disable interrupt (default value)
6	M0.6	R/W	1*	
5	M0.5	R/W	1*	
4	M0.4	R/W	1*	
3	M0.3	R/W	1*	
2	M0.2	R/W	1*	
1	M0.1	R/W	1*	
0	M0.0	R/W	1*	

7.5.8 Register 7 - Interrupt status register

This register is read-only. It is used to identify the source of interrupt.

Remark: If the interrupts are masked, this register will return all zeros.

Table 12. Register 7 - Interrupt status register (address 07h) bit description

Legend: * default value.

Bit	Symbol	Access	Value	Description
7	S0.7	read only	0*	identifies source of interrupt
6	S0.6	read only	0*	
5	S0.5	read only	0*	
4	S0.4	read only	0*	
3	S0.3	read only	0*	

Table 12. Register 7 - Interrupt status register (address 07h) bit description...continued

Legend: * default value.

Bit	Symbol	Access	Value	Description
2	S0.2	read only	0*	
1	S0.1	read only	0*	
0	S0.0	read only	0*	

7.6 Power-on reset

When power is applied to V_{DD}, an internal Power-On Reset (POR) holds the PCA9574 in a reset condition until V_{DD} has reached V_{POR}. At that point, the reset condition is released and the PCA9574 registers and state machine will initialize to their default states. The power-on reset typically completes the reset and enables the part by the time the power supply is above V_{POR}. However, when it is required to reset the part by lowering the power supply, it is necessary to lower it below 0.2 V.

7.7 RESET input

A reset can be accomplished by holding the $\overline{\text{RESET}}$ pin LOW for a minimum of t_{w(rst)}. The PCA9574 registers and I²C-bus state machine will be held in their default state until the $\overline{\text{RESET}}$ input is once again HIGH.

7.8 Software reset

The Software Reset Call allows all the devices in the I²C-bus to be reset to the power-up state value through a specific formatted I²C-bus command. To be performed correctly, it implies that the I²C-bus is functional and that there is no device hanging the bus.

The Software Reset sequence is defined as following:

1. A START command is sent by the I²C-bus controller.
2. The reserved General Call I²C-bus address '0000 000' with the R $\overline{\text{W}}$ bit set to 0 (write) is sent by the I²C-bus controller.
3. The PCA9574 device(s) acknowledge(s) after seeing the General Call address '0000 0000' (00h) only. If the R $\overline{\text{W}}$ bit is set to logic 1 (read), no acknowledge is returned to the I²C-bus controller.
4. Once the General Call address has been sent and acknowledged, the controller sends 1 byte. The value of the byte must be equal to 06h. The PCA9574 acknowledges this value only. If the byte is not equal to 06h, the PCA9574 does not acknowledge it. If more than 1 byte of data is sent, the PCA9574 does not acknowledge anymore.
5. Once the right byte has been sent and correctly acknowledged, the controller sends a STOP command to end the Software Reset sequence: the PCA9574 then resets to the default value (power-up value) and is ready to be addressed again within the specified bus free time. If the controller sends a Repeated START instead, no reset is performed. The I²C-bus controller must interpret a non-acknowledge from the PCA9574 (at any time) as a 'Software Reset Abort'. The PCA9574 does not initiate a software reset.

7.9 Interrupt output (INT)

The open-drain active LOW interrupt is activated when one of the port pins changes state and the port pin is configured as an input and the interrupt on it is not masked. The interrupt is deactivated when the port pin input returns to its previous state or the Input Port register is read. It is highly recommended to program the MSK register, and the CFG registers during the initialization sequence after power-up, since any change to them during Normal mode operation may cause undesirable interrupt events to happen.

Remark: Changing an I/O from an output to an input may cause a false interrupt to occur if the state of the pin does not match the contents of the Input port register. Only a read of the Input port register that contains the bit(s) image of the input(s) that generated the interrupt clears the interrupt condition.

7.10 Standby

The PCA9574 goes into standby when the I²C-bus is idle. Standby supply current is lower than 1.0 µA (typical).

8 Characteristics of the I²C-bus

The I²C-bus is for 2-way, 2-line communication between different ICs or modules. The two lines are a serial data line (SDA) and a serial clock line (SCL). Both lines must be connected to a positive supply via a pull-up resistor when connected to the output stages of a device. Data transfer may be initiated only when the bus is not busy.

8.1 Bit transfer

One data bit is transferred during each clock pulse. The data on the SDA line must remain stable during the HIGH period of the clock pulse as changes in the data line at this time will be interpreted as control signals (see [Figure 7](#)).

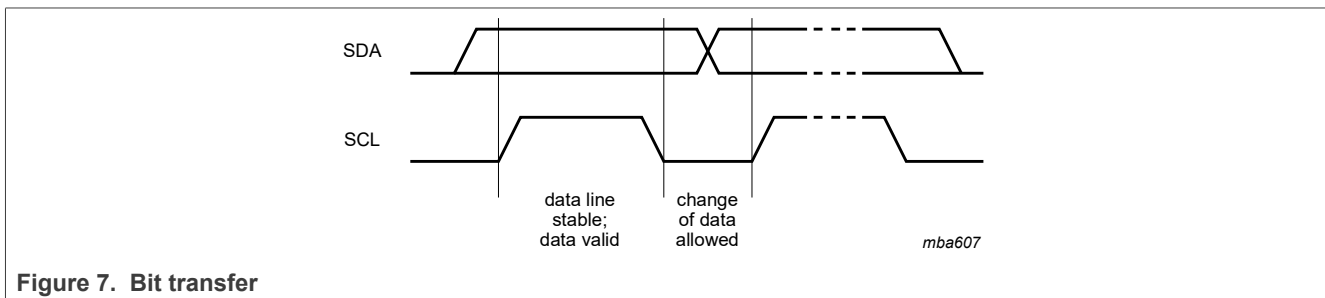

Figure 7. Bit transfer

8.1.1 START and STOP conditions

Both data and clock lines remain HIGH when the bus is not busy. A HIGH-to-LOW transition of the data line while the clock is HIGH is defined as the START condition (S). A LOW-to-HIGH transition of the data line while the clock is HIGH is defined as the STOP condition (P) (see [Figure 8](#)).

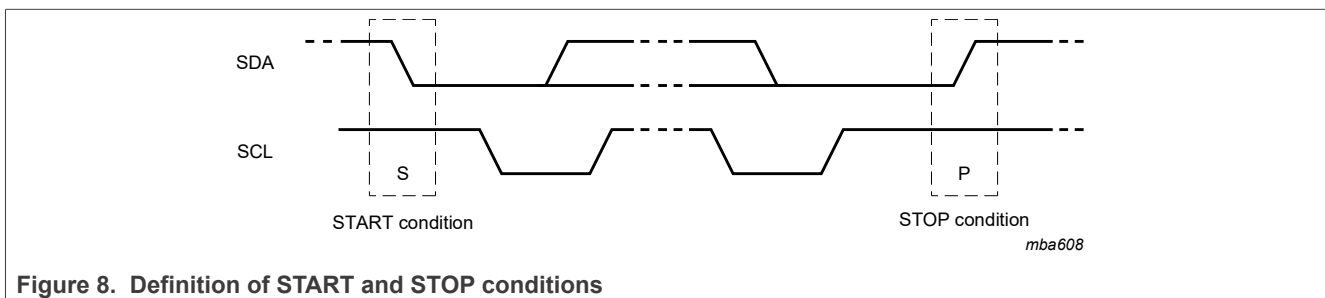

Figure 8. Definition of START and STOP conditions

8.2 System configuration

A device generating a message is a ‘transmitter’; a device receiving is the ‘receiver’. The device that controls the message is the ‘controller’ and the devices which are controlled by the controller are the ‘targets’ (see [Figure 9](#)).

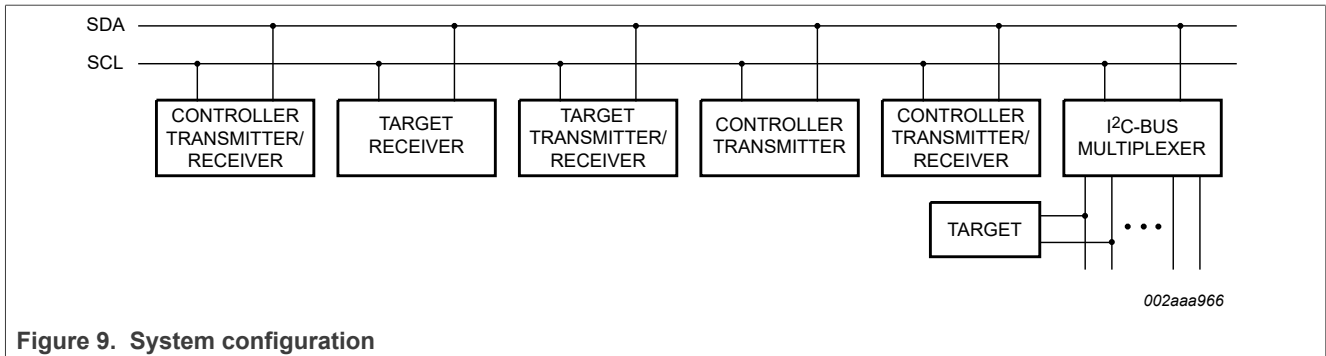

Figure 9. System configuration

8.3 Acknowledge

The number of data bytes transferred between the START and the STOP conditions from transmitter to receiver is not limited. Each byte of eight bits is followed by one acknowledge bit. The acknowledge bit is a HIGH level put on the bus by the transmitter, whereas the controller generates an extra acknowledge related clock pulse.

A target receiver which is addressed must generate an acknowledge after the reception of each byte. Also a controller must generate an acknowledge after the reception of each byte that has been clocked out of the target transmitter. The device that acknowledges has to pull down the SDA line during the acknowledge clock pulse, so that the SDA line is stable LOW during the HIGH period of the acknowledge related clock pulse; set-up time and hold time must be taken into account.

A controller receiver must signal an end of data to the transmitter by not generating an acknowledge on the last byte that has been clocked out of the target. In this event, the transmitter must leave the data line HIGH to enable the controller to generate a STOP condition.

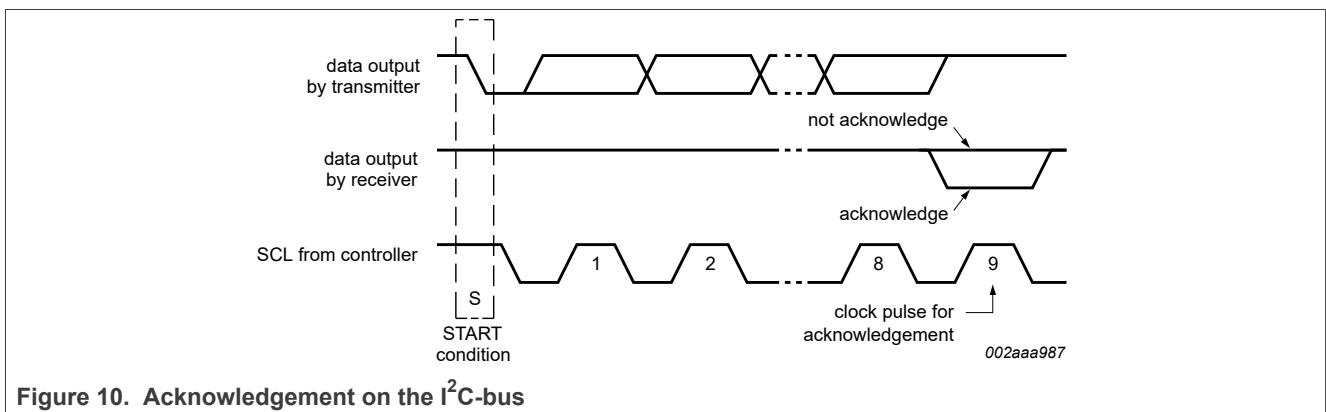

Figure 10. Acknowledgement on the I²C-bus

9 Bus transactions

Data is transmitted to the PCA9574 registers using ‘Write Byte’ transfers (see [Figure 11](#) and [Figure 12](#)).

Data is read from the PCA9574 registers using ‘Read Byte’ transfers (see [Figure 13](#) and [Figure 14](#)).

8-bit I²C-bus and SMBus, level translating, low voltage GPIO with reset and interrupt

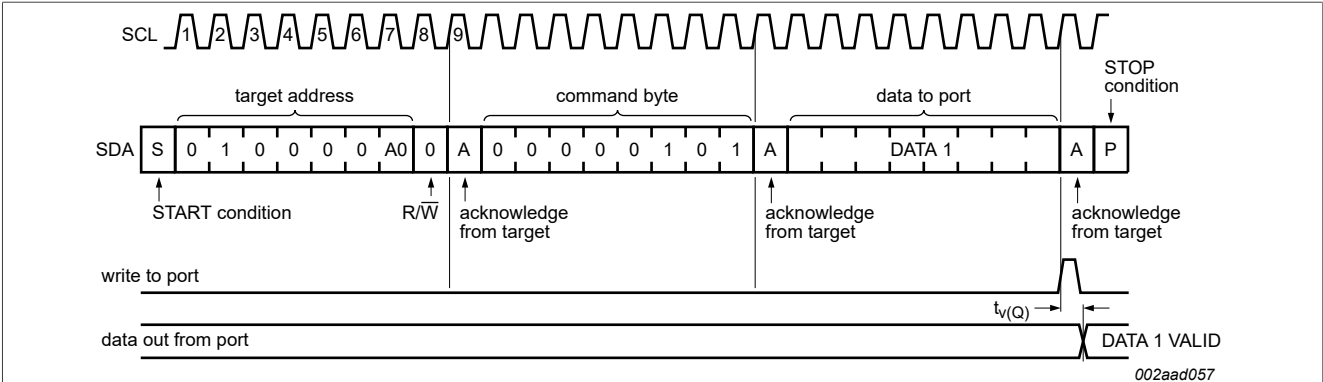

Figure 11. Write to Output port register

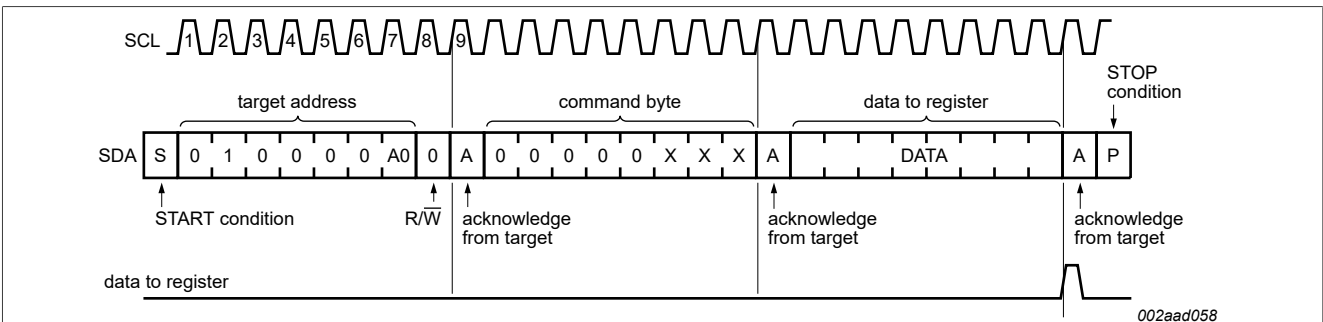

Figure 12. Write to Polarity inversion, Bus-hold enable, Pull-up/pull-down selector, Configuration, Interrupt mask and Interrupt status registers

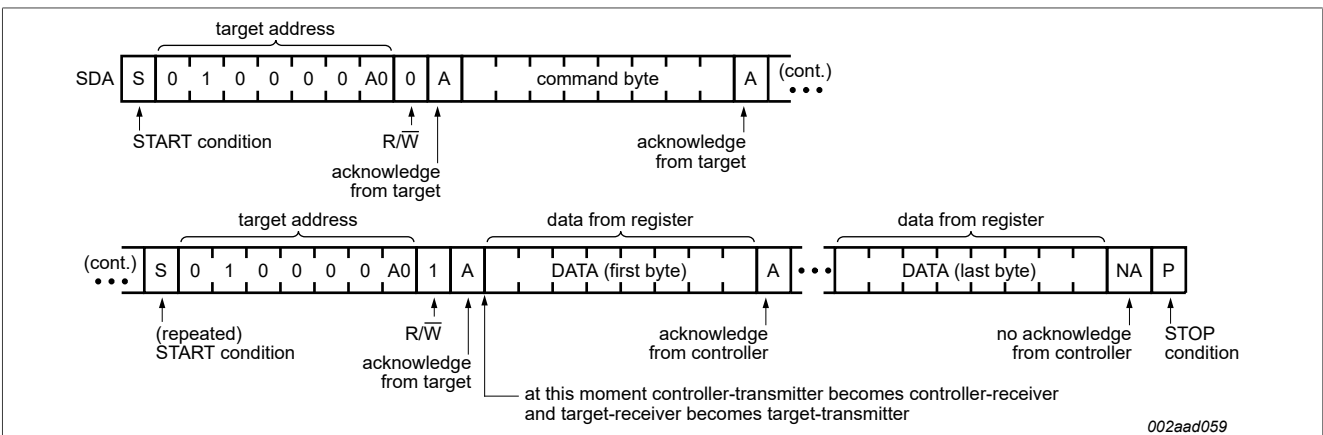
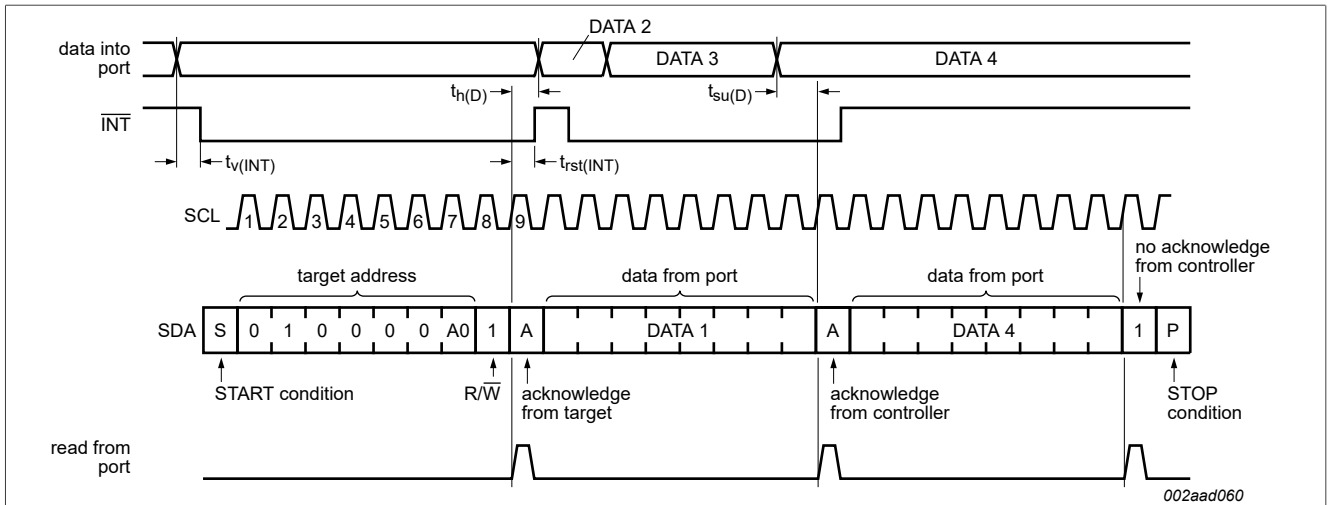

Figure 13. Read from register



This figure assumes the command byte has previously been programmed with 00h. Transfer of data can be stopped at any moment by a STOP condition.

Figure 14. Read Input port register

10 Application design-in information

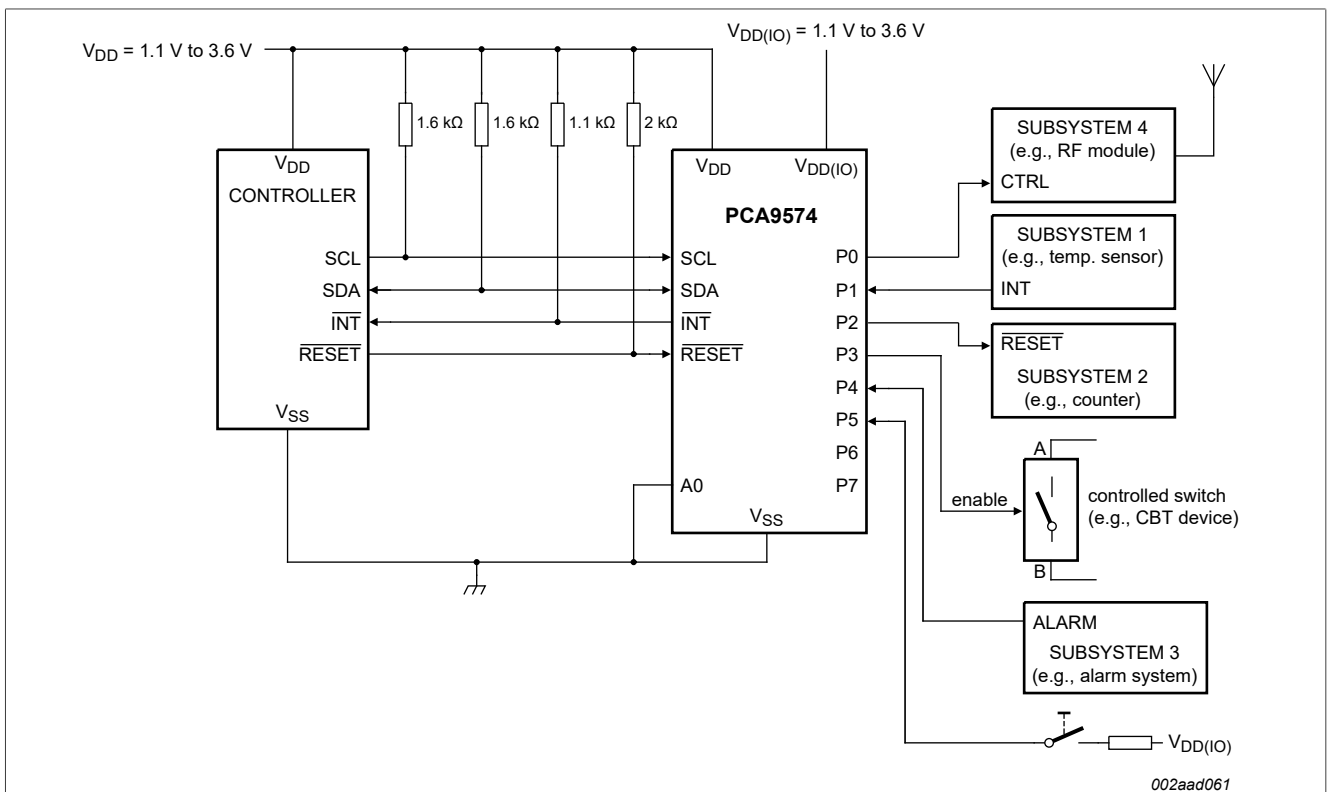

Device address configured as 0100 0000b for this example.
 P0, P2, P3 configured as outputs.
 P1, P4, P5 configured as inputs.
 P6, P7 are not used and must be configured as outputs.

Figure 15. Typical application

11 Limiting values

Table 13. Limiting values

In accordance with the Absolute Maximum Rating System (IEC 60134).

Symbol	Parameter	Conditions	Min	Max	Unit
V _{DD}	supply voltage		-0.5	+4.0	V
V _{DD(IO)}	input/output supply voltage		V _{SS} - 0.5	+4.0	V
I _{I/O}	input/output current		-	±5	mA
I _I	input current		-	±20	mA
I _{DD}	supply current		-	90	mA
I _{SS}	ground supply current		-	90	mA
P _{tot}	total power dissipation		-	75	mW
T _{stg}	storage temperature		-65	+150	°C
T _{amb}	ambient temperature		-40	+85	°C

12 Static characteristics

Table 14. Static characteristics

V_{DD} = 1.1 V to 3.6 V; V_{DD(IO)} = 1.1 V to 3.6 V; V_{SS} = 0 V; T_{amb} = -40 °C to +85 °C; unless otherwise specified.

Symbol	Parameter	Conditions	Min	Typ	Max	Unit
Supplies						
V _{DD}	supply voltage		1.1	-	3.6	V
V _{DD(IO)}	input/output supply voltage		1.1	-	3.6	V
I _{DD}	supply current	operating mode; V _{DD} = 3.6 V; no load; f _{SCL} = 100 kHz; I/O = inputs	-	135	200	µA
I _{stbL}	LOW-level standby current	Standby mode; V _{DD} = 3.6 V; no load; V _I = V _{SS} ; f _{SCL} = 0 kHz; I/O = inputs	-	0.25	1	µA
I _{stbH}	HIGH-level standby current	Standby mode; V _{DD} = 3.6 V; no load; V _I = V _{DD} ; f _{SCL} = 0 kHz; I/O = inputs	-	0.25	1	µA
V _{POR}	power-on reset voltage	no load; V _I = V _{DD} or V _{SS} (rising V _{DD})	-	0.8	1.0	V
Input SCL; input/output SDA						
V _{IL}	LOW-level input voltage		-0.5	-	+0.3V _{DD}	V
V _{IH}	HIGH-level input voltage		0.7V _{DD}	-	3.6	V
I _{OL}	LOW-level output current	V _{OL} = 0.2 V; V _{DD} = 1.1 V	1	-	-	mA
		V _{OL} = 0.4 V; V _{DD} = 2.3 V	3	-	-	mA
I _L	leakage current	V _I = V _{DD} or V _{SS}	-1	-	+1	µA
C _i	input capacitance	V _I = V _{SS}	-	6	10	pF
I/Os						
V _{IL}	LOW-level input voltage		-0.5	-	+0.3V _{DD(IO)}	V
V _{IH}	HIGH-level input voltage		0.7V _{DD(IO)}	-	V _{DD(IO)} + 0.3	V

8-bit I²C-bus and SMBus, level translating, low voltage GPIO with reset and interrupt

Table 14. Static characteristics...continued

V_{DD} = 1.1 V to 3.6 V; V_{DD(IO)} = 1.1 V to 3.6 V; V_{SS} = 0 V; T_{amb} = -40 °C to +85 °C; unless otherwise specified.

Symbol	Parameter	Conditions	Min	Typ	Max	Unit
I _{OH}	HIGH-level output current	V _{OH} = 0.9 V; V _{DD(IO)} = 1.1 V	1	-	-	mA
I _{OL}	LOW-level output current	V _{OL} = 0.2 V; V _{DD(IO)} = 1.1 V	1	-	-	mA
		V _{OL} = 0.5 V; V _{DD(IO)} = 3.6 V	2	3	-	mA
V _{OH}	HIGH-level output voltage	I _{OH} = -1 mA; V _{DD(IO)} = 1.1 V	0.8	-	V _{DD(IO)}	V
I _{LIH}	HIGH-level input leakage current	V _{DD(IO)} = 3.6 V; V _I = V _{DD(IO)}	-	-	1	µA
I _{LIL}	LOW-level input leakage current	V _{DD(IO)} = 3.6 V; V _I = V _{SS}	-	-	-1	µA
C _i	input capacitance		-	3.7	5	pF
C _o	output capacitance		-	3.7	5	pF
Interrupt INT						
I _{OL}	LOW-level output current	V _{OL} = 0.4 V; V _{DD} = 1.1 V	3	-	-	mA
Select input A0; RESET						
V _{IL}	LOW-level input voltage		-0.5	-	+0.3V _{DD}	V
V _{IH}	HIGH-level input voltage		0.7V _{DD}	-	3.6	V
I _{LI}	input leakage current	V _I = V _{DD} or V _{SS}	-1	-	+1	µA

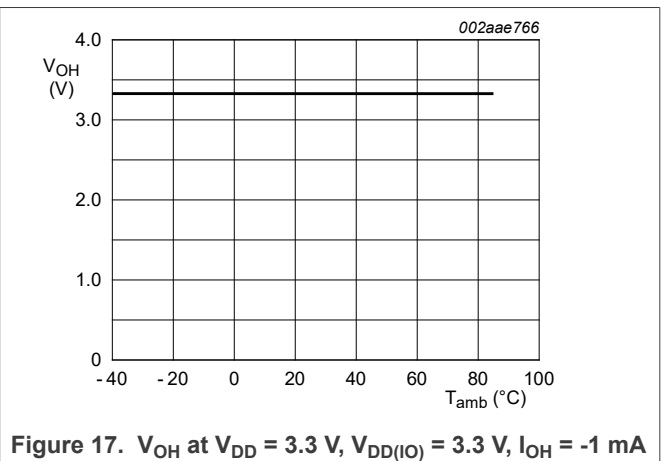
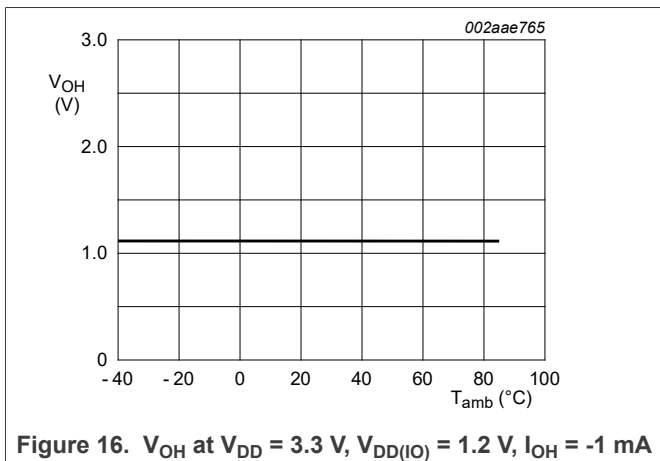

13 Dynamic characteristics

Table 15. Dynamic characteristics

V_{DD} = 1.1 V to 3.6 V; V_{DD(IO)} = 1.1 V to 3.6 V; V_{SS} = 0 V; T_{amb} = -40 °C to +85 °C; unless otherwise specified.

Symbol	Parameter	Conditions	Standard-mode I ² C-bus		Fast-mode I ² C-bus		Unit
			Min	Max	Min	Max	
f _{SCL}	SCL clock frequency		0	100	0	400	kHz

8-bit I²C-bus and SMBus, level translating, low voltage GPIO with reset and interrupt

Table 15. Dynamic characteristics...continued

$V_{DD} = 1.1\text{ V to }3.6\text{ V}$; $V_{DD(I/O)} = 1.1\text{ V to }3.6\text{ V}$; $V_{SS} = 0\text{ V}$; $T_{amb} = -40\text{ }^{\circ}\text{C to }+85\text{ }^{\circ}\text{C}$; unless otherwise specified.

Symbol	Parameter	Conditions	Standard-mode I ² C-bus		Fast-mode I ² C-bus		Unit
			Min	Max	Min	Max	
t _{BUF}	bus free time between a STOP and START condition		4.7	-	1.3	-	μs
t _{HD,STA}	hold time (repeated) START condition		4.0	-	0.6	-	μs
t _{SU,STA}	set-up time for a repeated START condition		4.7	-	0.6	-	μs
t _{SU,STO}	set-up time for STOP condition		4.0	-	0.6	-	μs
t _{VD,ACK}	data valid acknowledge time	[1]	0.3	3.45	0.1	0.9	μs
t _{HD,DAT}	data hold time		0	-	0	-	ns
t _{VD,DAT}	data valid time	[2]	300	-	50	-	ns
t _{SU,DAT}	data set-up time		250	-	100	-	ns
t _{LOW}	LOW period of the SCL clock		4.7	-	1.3	-	μs
t _{HIGH}	HIGH period of the SCL clock		4.0	-	0.6	-	μs
t _f	fall time of both SDA and SCL signals		-	300	20 + 0.1C _b ^[3]	300	ns
t _r	rise time of both SDA and SCL signals		-	1000	20 + 0.1C _b ^[3]	300	ns
t _{SP}	pulse width of spikes that must be suppressed by the input filter		-	50	-	50	ns
Port timing							
t _{v(Q)}	data output valid time		-	200	-	200	ns
t _{su(D)}	data input set-up time		150	-	150	-	ns
t _{h(D)}	data input hold time		1	-	1	-	μs
Interrupt timing							
t _{v(INT)}	valid time on pin INT		-	4	-	4	μs
t _{rst(INT)}	reset time on pin INT		-	4	-	4	μs
Reset							
t _{w(rst)}	reset pulse width		6	-	6	-	ns
t _{rec(rst)}	reset recovery time		0	-	0	-	ns
t _{rst(SDA)}	SDA reset time	Figure 19	-	450	-	450	ns
t _{rst(GPIO)}	GPIO reset time	Figure 19	-	450	-	450	ns

[1] t_{VD,ACK} = time for acknowledgement signal from SCL LOW to SDA (out) LOW.

[2] t_{VD,DAT} = minimum time for SDA data out to be valid following SCL LOW.

[3] C_b = total capacitance of one bus line in pF.

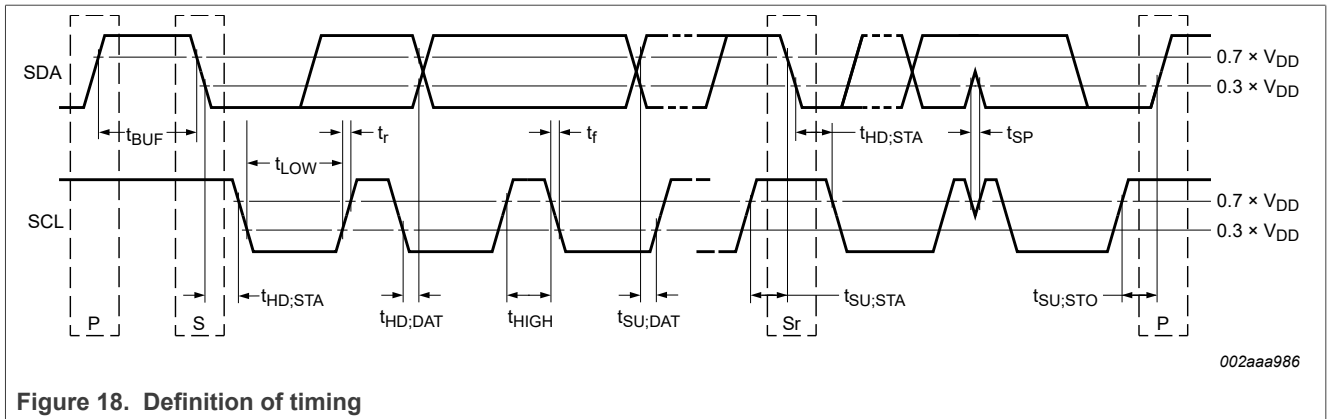

Figure 18. Definition of timing

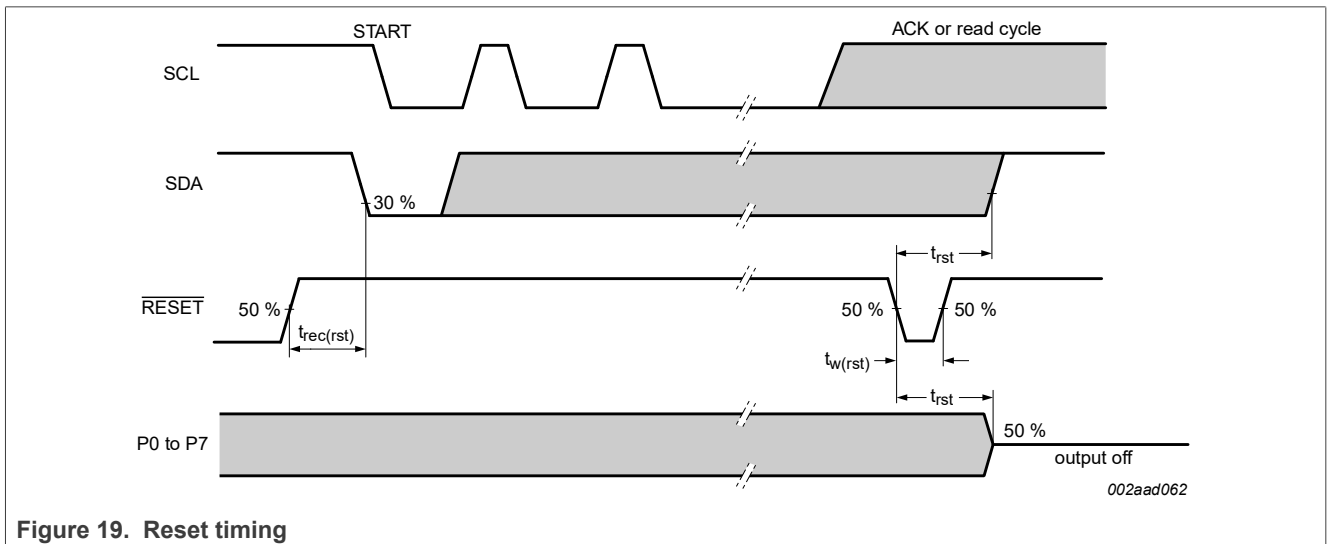

Figure 19. Reset timing

14 Test information

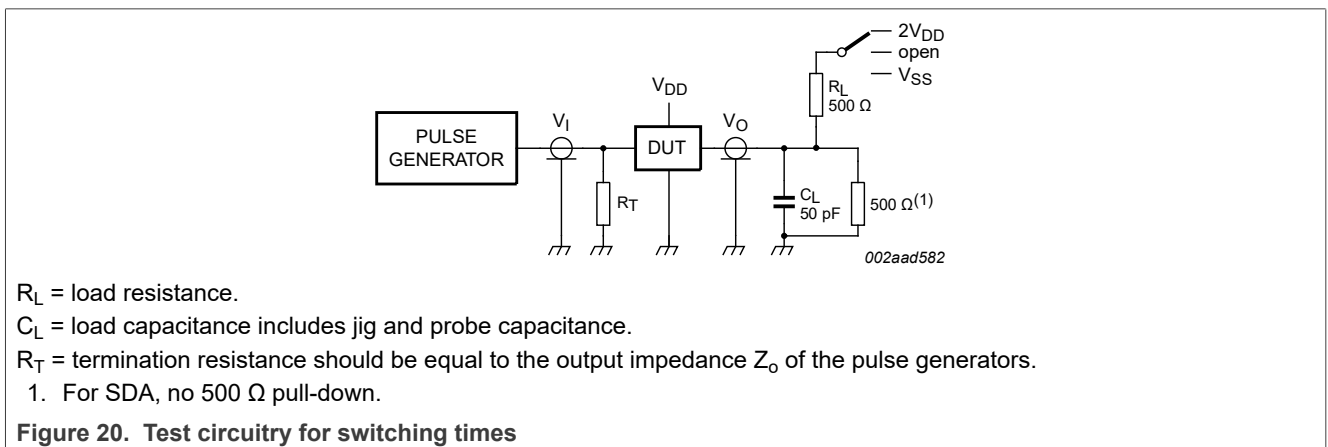
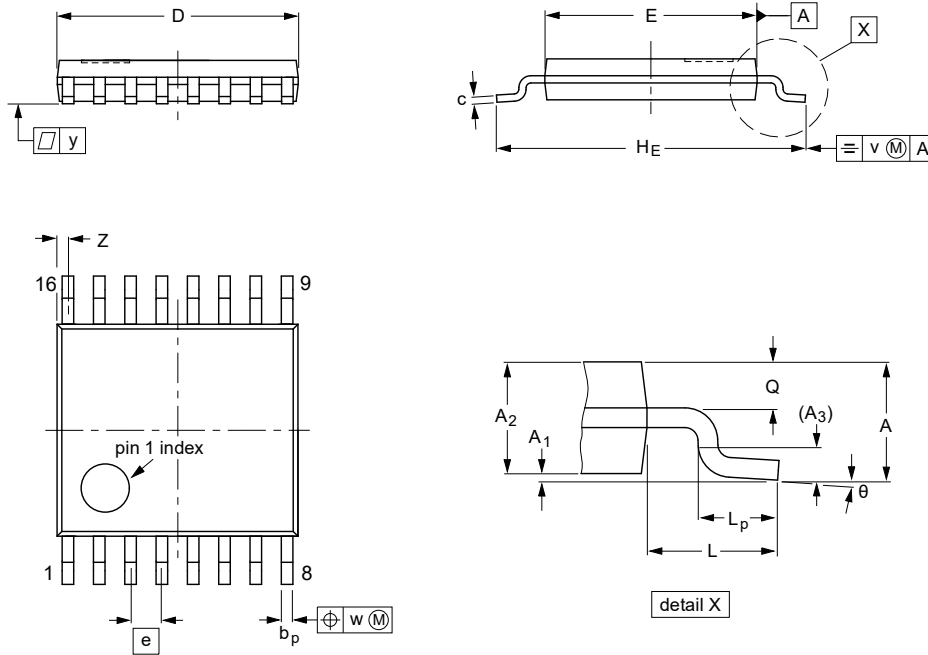

Figure 20. Test circuitry for switching times

15 Package outline

TSSOP16: plastic thin shrink small outline package; 16 leads; body width 4.4 mm

SOT403-1



DIMENSIONS (mm are the original dimensions)

UNIT	A max.	A ₁	A ₂	A ₃	b _p	c	D ⁽¹⁾	E ⁽²⁾	e	H _E	L	L _p	Q	v	w	y	Z ⁽¹⁾	θ
mm	1.1	0.15 0.05	0.95 0.80	0.25	0.30 0.19	0.2 0.1	5.1 4.9	4.5 4.3	0.65	6.6 6.2	1	0.75 0.50	0.4 0.3	0.2	0.13	0.1	0.40 0.06	8° 0°

Notes

1. Plastic or metal protrusions of 0.15 mm maximum per side are not included.
2. Plastic interlead protrusions of 0.25 mm maximum per side are not included.

OUTLINE VERSION	REFERENCES				EUROPEAN PROJECTION	ISSUE DATE
	IEC	JEDEC	JEITA			
SOT403-1		MO-153				99-12-27 03-02-18

Figure 21. Package outline SOT403-1 (TSSOP16)

HVQFN16: plastic thermal enhanced very thin quad flat package; no leads;
16 terminals; body 3 x 3 x 0.85 mm

SOT758-1

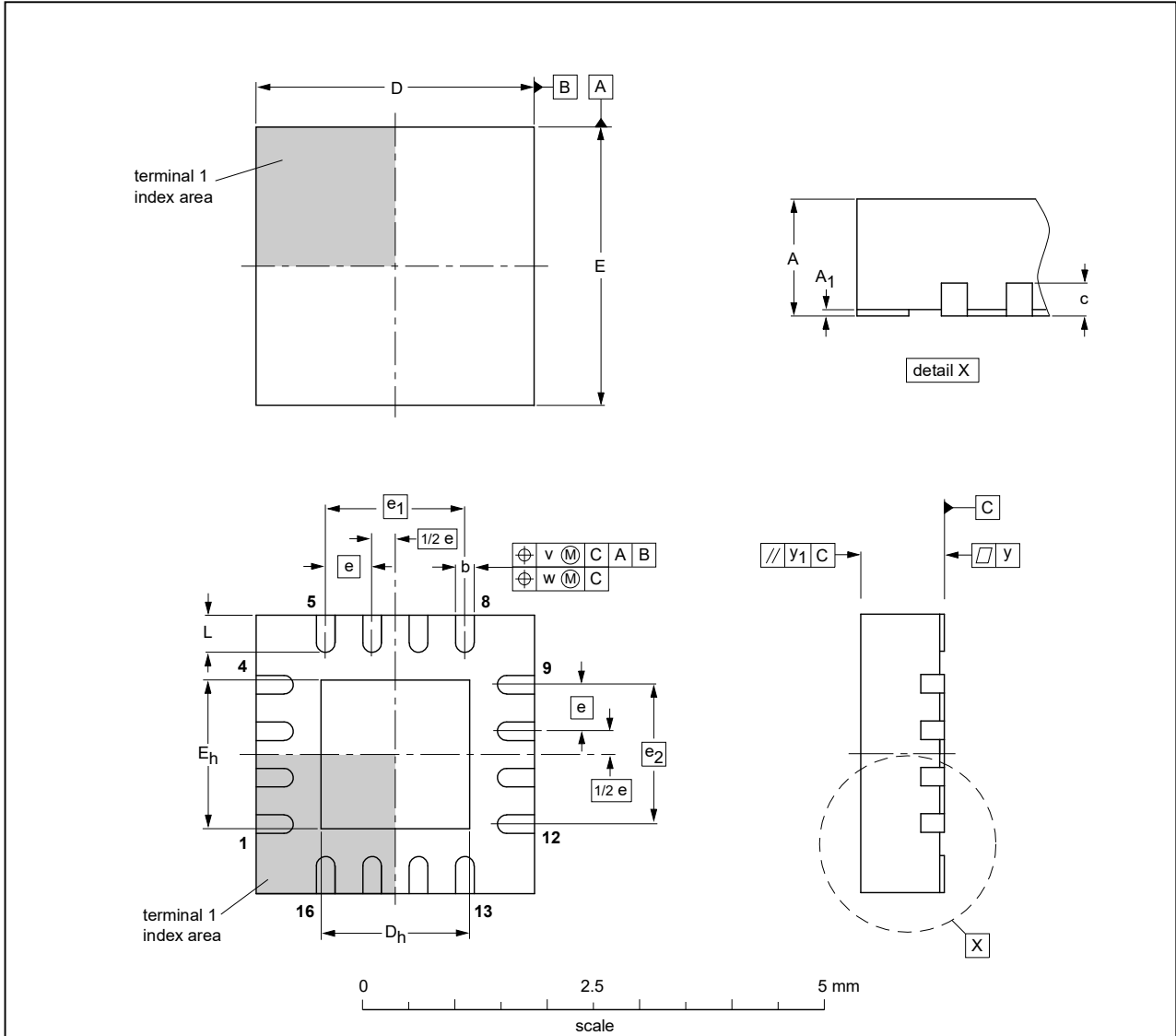

DIMENSIONS (mm are the original dimensions)

UNIT	A ⁽¹⁾ max.	A ₁	b	c	D ⁽¹⁾	D _h	E ⁽¹⁾	E _h	e	e ₁	e ₂	L	v	w	y	y ₁
mm	1	0.05 0.00	0.30 0.18	0.2	3.1 2.9	1.75 1.45	3.1 2.9	1.75 1.45	0.5	1.5	1.5	0.5 0.3	0.1	0.05	0.05	0.1

Note

1. Plastic or metal protrusions of 0.075 mm maximum per side are not included.

OUTLINE VERSION	REFERENCES			EUROPEAN PROJECTION	ISSUE DATE
	IEC	JEDEC	JEITA		
SOT758-1	---	MO-220	---		-02-03-25- 02-10-21

Figure 22. Package outline SOT758-1 (HVQFN16)

16 Handling information

All input and output pins are protected against ElectroStatic Discharge (ESD) under normal handling. When handling ensure that the appropriate precautions are taken as described in *JESD625-A* or equivalent standards.

17 Soldering of SMD packages

This text provides a very brief insight into a complex technology. A more in-depth account of soldering ICs can be found in Application Note *AN10365 "Surface mount reflow soldering description"*.

17.1 Introduction to soldering

Soldering is one of the most common methods through which packages are attached to Printed Circuit Boards (PCBs), to form electrical circuits. The soldered joint provides both the mechanical and the electrical connection. There is no single soldering method that is ideal for all IC packages. Wave soldering is often preferred when through-hole and Surface Mount Devices (SMDs) are mixed on one printed wiring board; however, it is not suitable for fine pitch SMDs. Reflow soldering is ideal for the small pitches and high densities that come with increased miniaturization.

17.2 Wave and reflow soldering

Wave soldering is a joining technology in which the joints are made by solder coming from a standing wave of liquid solder. The wave soldering process is suitable for the following:

- Through-hole components
- Leaded or leadless SMDs, which are glued to the surface of the printed circuit board

Not all SMDs can be wave soldered. Packages with solder balls, and some leadless packages which have solder lands underneath the body, cannot be wave soldered. Also, leaded SMDs with leads having a pitch smaller than ~0.6 mm cannot be wave soldered, due to an increased probability of bridging.

The reflow soldering process involves applying solder paste to a board, followed by component placement and exposure to a temperature profile. Leaded packages, packages with solder balls, and leadless packages are all reflow solderable.

Key characteristics in both wave and reflow soldering are:

- Board specifications, including the board finish, solder masks and vias
- Package footprints, including solder thieves and orientation
- The moisture sensitivity level of the packages
- Package placement
- Inspection and repair
- Lead-free soldering versus SnPb soldering

17.3 Wave soldering

Key characteristics in wave soldering are:

- Process issues, such as application of adhesive and flux, clinching of leads, board transport, the solder wave parameters, and the time during which components are exposed to the wave
- Solder bath specifications, including temperature and impurities

17.4 Reflow soldering

Key characteristics in reflow soldering are:

- Lead-free versus SnPb soldering; note that a lead-free reflow process usually leads to higher minimum peak temperatures (see [Figure 23](#)) than a SnPb process, thus reducing the process window
- Solder paste printing issues including smearing, release, and adjusting the process window for a mix of large and small components on one board
- Reflow temperature profile; this profile includes preheat, reflow (in which the board is heated to the peak temperature) and cooling down. It is imperative that the peak temperature is high enough for the solder to make reliable solder joints (a solder paste characteristic). In addition, the peak temperature must be low enough that the packages and/or boards are not damaged. The peak temperature of the package depends on package thickness and volume and is classified in accordance with [Table 16](#) and [Table 17](#)

Table 16. SnPb eutectic process (from J-STD-020D)

Package thickness (mm)	Package reflow temperature (°C)	
	Volume (mm ³)	
	< 350	≥ 350
< 2.5	235	220
≥ 2.5	220	220

Table 17. Lead-free process (from J-STD-020D)

Package thickness (mm)	Package reflow temperature (°C)		
	Volume (mm ³)		
	< 350	350 to 2000	> 2000
< 1.6	260	260	260
1.6 to 2.5	260	250	245
> 2.5	250	245	245

Moisture sensitivity precautions, as indicated on the packing, must be respected at all times.

Studies have shown that small packages reach higher temperatures during reflow soldering, see [Figure 23](#).

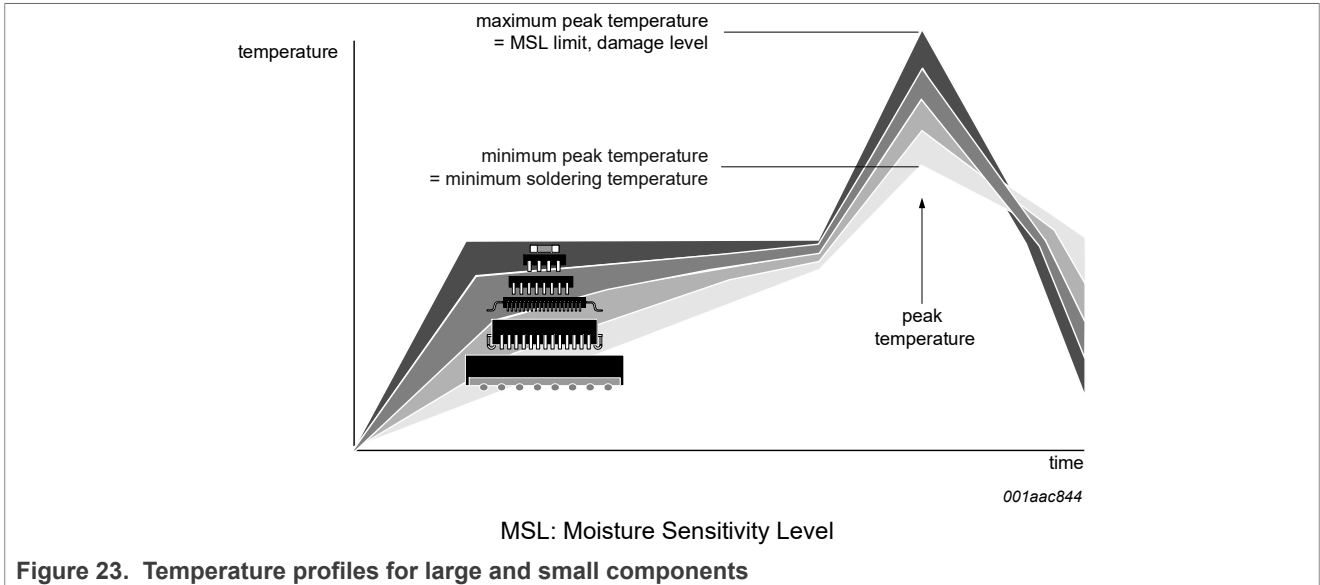

Figure 23. Temperature profiles for large and small components

For further information on temperature profiles, refer to Application Note AN10365 “Surface mount reflow soldering description”.

18 Abbreviations

Table 18. Abbreviations

Acronym	Description
CBT	Cross Bar Technology
CDM	Charged-Device Model
CMOS	Complementary Metal-Oxide Semiconductor
DUT	Device Under Test
ESD	ElectroStatic Discharge
GPIO	General Purpose Input/Output
HBM	Human Body Model
I/O	Input/Output
I ² C-bus	Inter-Integrated Circuit bus
IC	Integrated Circuit
LED	Light Emitting Diode
LP	Low Pass
PCB	Printed-Circuit Board
PLC	Programmable Logic Controller
POR	Power-On Reset
RAID	Redundant Array of Independent Discs
SMBus	System Management Bus

19 Revision history

Table 19. Revision history

Document ID	Release date	Data sheet status	Change notice	Supersedes
PCA9574 v.6.0	20230518	Product data sheet	202301013I	PCA9574 v.5
Modifications:	<ul style="list-style-type: none"> • Table 13: Updated $V_{DD(I/O)}$ max • Table 14: Updated $V_{DD(I/O)}$ (Supplies), V_{IH} and V_{OH} (I/Os) max • Updated Figure 15 • Replaced deprecated terms 'master' and 'slave' with 'controller' and 'target' respectively in accordance with NXP's inclusive language policy 			
PCA9574 v.5	20140925	Product data sheet	-	PCA9574 v.4
PCA9574 v.4	20120425	Product data sheet	-	PCA9574 v.3
PCA9574 v.3	20110622	Product data sheet	-	PCA9574 v.2
PCA9574 v.2	20090727	Product data sheet	-	PCA9574 v.1
PCA9574 v.1	20080515	Product data sheet	-	-

20 Legal information

20.1 Data sheet status

Document status ^{[1][2]}	Product status ^[3]	Definition
Objective [short] data sheet	Development	This document contains data from the objective specification for product development.
Preliminary [short] data sheet	Qualification	This document contains data from the preliminary specification.
Product [short] data sheet	Production	This document contains the product specification.

[1] Please consult the most recently issued document before initiating or completing a design.

[2] The term 'short data sheet' is explained in section "Definitions".

[3] The product status of device(s) described in this document may have changed since this document was published and may differ in case of multiple devices. The latest product status information is available on the Internet at URL <http://www.nxp.com>.

20.2 Definitions

Draft — A draft status on a document indicates that the content is still under internal review and subject to formal approval, which may result in modifications or additions. NXP Semiconductors does not give any representations or warranties as to the accuracy or completeness of information included in a draft version of a document and shall have no liability for the consequences of use of such information.

Short data sheet — A short data sheet is an extract from a full data sheet with the same product type number(s) and title. A short data sheet is intended for quick reference only and should not be relied upon to contain detailed and full information. For detailed and full information see the relevant full data sheet, which is available on request via the local NXP Semiconductors sales office. In case of any inconsistency or conflict with the short data sheet, the full data sheet shall prevail.

Product specification — The information and data provided in a Product data sheet shall define the specification of the product as agreed between NXP Semiconductors and its customer, unless NXP Semiconductors and customer have explicitly agreed otherwise in writing. In no event however, shall an agreement be valid in which the NXP Semiconductors product is deemed to offer functions and qualities beyond those described in the Product data sheet.

20.3 Disclaimers

Limited warranty and liability — Information in this document is believed to be accurate and reliable. However, NXP Semiconductors does not give any representations or warranties, expressed or implied, as to the accuracy or completeness of such information and shall have no liability for the consequences of use of such information. NXP Semiconductors takes no responsibility for the content in this document if provided by an information source outside of NXP Semiconductors.

In no event shall NXP Semiconductors be liable for any indirect, incidental, punitive, special or consequential damages (including - without limitation - lost profits, lost savings, business interruption, costs related to the removal or replacement of any products or rework charges) whether or not such damages are based on tort (including negligence), warranty, breach of contract or any other legal theory.

Notwithstanding any damages that customer might incur for any reason whatsoever, NXP Semiconductors' aggregate and cumulative liability towards customer for the products described herein shall be limited in accordance with the Terms and conditions of commercial sale of NXP Semiconductors.

Right to make changes — NXP Semiconductors reserves the right to make changes to information published in this document, including without limitation specifications and product descriptions, at any time and without notice. This document supersedes and replaces all information supplied prior to the publication hereof.

Suitability for use — NXP Semiconductors products are not designed, authorized or warranted to be suitable for use in life support, life-critical or safety-critical systems or equipment, nor in applications where failure or malfunction of an NXP Semiconductors product can reasonably be expected to result in personal injury, death or severe property or environmental damage. NXP Semiconductors and its suppliers accept no liability for inclusion and/or use of NXP Semiconductors products in such equipment or applications and therefore such inclusion and/or use is at the customer's own risk.

Applications — Applications that are described herein for any of these products are for illustrative purposes only. NXP Semiconductors makes no representation or warranty that such applications will be suitable for the specified use without further testing or modification.

Customers are responsible for the design and operation of their applications and products using NXP Semiconductors products, and NXP Semiconductors accepts no liability for any assistance with applications or customer product design. It is customer's sole responsibility to determine whether the NXP Semiconductors product is suitable and fit for the customer's applications and products planned, as well as for the planned application and use of customer's third party customer(s). Customers should provide appropriate design and operating safeguards to minimize the risks associated with their applications and products.

NXP Semiconductors does not accept any liability related to any default, damage, costs or problem which is based on any weakness or default in the customer's applications or products, or the application or use by customer's third party customer(s). Customer is responsible for doing all necessary testing for the customer's applications and products using NXP Semiconductors products in order to avoid a default of the applications and the products or of the application or use by customer's third party customer(s). NXP does not accept any liability in this respect.

Limiting values — Stress above one or more limiting values (as defined in the Absolute Maximum Ratings System of IEC 60134) will cause permanent damage to the device. Limiting values are stress ratings only and (proper) operation of the device at these or any other conditions above those given in the Recommended operating conditions section (if present) or the Characteristics sections of this document is not warranted. Constant or repeated exposure to limiting values will permanently and irreversibly affect the quality and reliability of the device.

Terms and conditions of commercial sale — NXP Semiconductors products are sold subject to the general terms and conditions of commercial sale, as published at <http://www.nxp.com/profile/terms>, unless otherwise agreed in a valid written individual agreement. In case an individual agreement is concluded only the terms and conditions of the respective agreement shall apply. NXP Semiconductors hereby expressly objects to applying the customer's general terms and conditions with regard to the purchase of NXP Semiconductors products by customer.

No offer to sell or license — Nothing in this document may be interpreted or construed as an offer to sell products that is open for acceptance or the grant, conveyance or implication of any license under any copyrights, patents or other industrial or intellectual property rights.

8-bit I²C-bus and SMBus, level translating, low voltage GPIO with reset and interrupt

Quick reference data — The Quick reference data is an extract of the product data given in the Limiting values and Characteristics sections of this document, and as such is not complete, exhaustive or legally binding.

Export control — This document as well as the item(s) described herein may be subject to export control regulations. Export might require a prior authorization from competent authorities.

Suitability for use in non-automotive qualified products — Unless this data sheet expressly states that this specific NXP Semiconductors product is automotive qualified, the product is not suitable for automotive use. It is neither qualified nor tested in accordance with automotive testing or application requirements. NXP Semiconductors accepts no liability for inclusion and/or use of non-automotive qualified products in automotive equipment or applications.

In the event that customer uses the product for design-in and use in automotive applications to automotive specifications and standards, customer (a) shall use the product without NXP Semiconductors' warranty of the product for such automotive applications, use and specifications, and (b) whenever customer uses the product for automotive applications beyond NXP Semiconductors' specifications such use shall be solely at customer's own risk, and (c) customer fully indemnifies NXP Semiconductors for any liability, damages or failed product claims resulting from customer design and use of the product for automotive applications beyond NXP Semiconductors' standard warranty and NXP Semiconductors' product specifications.

Translations — A non-English (translated) version of a document, including the legal information in that document, is for reference only. The English version shall prevail in case of any discrepancy between the translated and English versions.

Security — Customer understands that all NXP products may be subject to unidentified vulnerabilities or may support established security standards or specifications with known limitations. Customer is responsible for the design and operation of its applications and products throughout their lifecycles to reduce the effect of these vulnerabilities on customer's applications and products. Customer's responsibility also extends to other open and/or proprietary technologies supported by NXP products for use in customer's applications. NXP accepts no liability for any vulnerability. Customer should regularly check security updates from NXP and follow up appropriately.

Customer shall select products with security features that best meet rules, regulations, and standards of the intended application and make the ultimate design decisions regarding its products and is solely responsible for compliance with all legal, regulatory, and security related requirements concerning its products, regardless of any information or support that may be provided by NXP.

NXP has a Product Security Incident Response Team (PSIRT) (reachable at PSIRT@nxp.com) that manages the investigation, reporting, and solution release to security vulnerabilities of NXP products.

20.4 Trademarks

Notice: All referenced brands, product names, service names, and trademarks are the property of their respective owners.

NXP — wordmark and logo are trademarks of NXP B.V.

I²C-bus — logo is a trademark of NXP B.V.

Tables

Tab. 1.	Ordering information	2	Tab. 10.	Register 5 - Output port register (address 05h) bit description	10
Tab. 2.	Ordering options	3	Tab. 11.	Register 6 - Interrupt mask register (address 06h) bit description	10
Tab. 3.	Pin description	5	Tab. 12.	Register 7 - Interrupt status register (address 07h) bit description	10
Tab. 4.	Register summary	6	Tab. 13.	Limiting values	16
Tab. 5.	Register 0 - Input port register (address 00h) bit description	7	Tab. 14.	Static characteristics	16
Tab. 6.	Register 1 - Polarity inversion register (address 01h) bit description	8	Tab. 15.	Dynamic characteristics	17
Tab. 7.	Register 2 - Bus-hold/pull-up/pull-down enable register (address 02h) bit description	8	Tab. 16.	SnPb eutectic process (from J-STD-020D)	23
Tab. 8.	Register 3 - Pull-up/pull-down selector register (address 03h) bit description	9	Tab. 17.	Lead-free process (from J-STD-020D)	23
Tab. 9.	Register 4 - Configuration register (address 04h) bit description	9	Tab. 18.	Abbreviations	24
			Tab. 19.	Revision history	25

Figures

Fig. 1.	Block diagram of PCA9574	3	Fig. 13.	Read from register	14
Fig. 2.	Simplified schematic of the I/Os (P0 to P7)	4	Fig. 14.	Read Input port register	15
Fig. 3.	Pin configuration for TSSOP16	5	Fig. 15.	Typical application	15
Fig. 4.	Pin configuration for HVQFN16	5	Fig. 16.	VOH at VDD = 3.3 V, VDD(IO) = 1.2 V, IOH = -1 mA	17
Fig. 5.	PCA9574 device address	6	Fig. 17.	VOH at VDD = 3.3 V, VDD(IO) = 3.3 V, IOH = -1 mA	17
Fig. 6.	Command register	6	Fig. 18.	Definition of timing	19
Fig. 7.	Bit transfer	12	Fig. 19.	Reset timing	19
Fig. 8.	Definition of START and STOP conditions	12	Fig. 20.	Test circuitry for switching times	19
Fig. 9.	System configuration	13	Fig. 21.	Package outline SOT403-1 (TSSOP16)	20
Fig. 10.	Acknowledgement on the I2C-bus	13	Fig. 22.	Package outline SOT758-1 (HVQFN16)	21
Fig. 11.	Write to Output port register	14	Fig. 23.	Temperature profiles for large and small components	24
Fig. 12.	Write to Polarity inversion, Bus-hold enable, Pull-up/pull-down selector, Configuration, Interrupt mask and Interrupt status registers	14			

Contents

1	General description	1
2	Features and benefits	1
3	Applications	2
4	Ordering information	2
4.1	Ordering options	3
5	Block diagram	3
6	Pinning information	5
6.1	Pinning	5
6.2	Pin description	5
7	Functional description	6
7.1	Device address	6
7.2	Command register	6
7.3	Register definitions	6
7.4	Writing to port registers	7
7.5	Reading the port registers	7
7.5.1	Register 0 - Input port register	7
7.5.2	Register 1 - Polarity inversion register	8
7.5.3	Register 2 - Bus-hold/pull-up/pull-down enable register	8
7.5.4	Register 3 - Pull-up/pull-down selector register	9
7.5.5	Register 4 - Configuration register	9
7.5.6	Register 5 - Output port register	9
7.5.7	Register 6 - Interrupt mask register	10
7.5.8	Register 7 - Interrupt status register	10
7.6	Power-on reset	11
7.7	RESET input	11
7.8	Software reset	11
7.9	Interrupt output (INT)	11
7.10	Standby	12
8	Characteristics of the I²C-bus	12
8.1	Bit transfer	12
8.1.1	START and STOP conditions	12
8.2	System configuration	12
8.3	Acknowledge	13
9	Bus transactions	13
10	Application design-in information	15
11	Limiting values	16
12	Static characteristics	16
13	Dynamic characteristics	17
14	Test information	19
15	Package outline	20
16	Handling information	22
17	Soldering of SMD packages	22
17.1	Introduction to soldering	22
17.2	Wave and reflow soldering	22
17.3	Wave soldering	22
17.4	Reflow soldering	23
18	Abbreviations	24
19	Revision history	25
20	Legal information	26

Please be aware that important notices concerning this document and the product(s) described herein, have been included in section 'Legal information'.