



P82B96

Dual bidirectional bus buffer

Rev. 06 — 31 January 2008

Product data sheet

1. General description

The P82B96 is a bipolar IC that creates a non-latching, bidirectional, logic interface between the normal I²C-bus and a range of other bus configurations. It can interface I²C-bus logic signals to similar buses having different voltage and current levels.

For example, it can interface to the 350 μ A SMBus, to 3.3 V logic devices, and to 15 V levels and/or low-impedance lines to improve noise immunity on longer bus lengths.

It achieves this interface without any restrictions on the normal I²C-bus protocols or clock speed. The IC adds minimal loading to the I²C-bus node, and loadings of the new bus or remote I²C-bus nodes are not transmitted or transformed to the local node. Restrictions on the number of I²C-bus devices in a system, or the physical separation between them, are virtually eliminated. Transmitting SDA and SCL signals via balanced transmission lines (twisted pairs) or with galvanic isolation (opto-coupling) is simple because separate directional Tx and Rx signals are provided. The Tx and Rx signals may be directly connected, without causing latching, to provide an alternative bidirectional signal line with I²C-bus properties.

2. Features

- Bidirectional data transfer of I²C-bus signals
- Isolates capacitance allowing 400 pF on Sx/Sy side and 4000 pF on Tx/Ty side
- Tx/Ty outputs have 60 mA sink capability for driving low-impedance or high capacitive buses
- 400 kHz operation over at least 20 meters of wire (see *AN10148*)
- Supply voltage range of 2 V to 15 V with I²C-bus logic levels on Sx/Sy side independent of supply voltage
- Splits I²C-bus signal into pairs of forward/reverse Tx/Rx, Ty/Ry signals for interface with opto-electrical isolators and similar devices that need unidirectional input and output signal paths.
- Low power supply current
- ESD protection exceeds 3500 V HBM per JESD22-A114, 250 V DIP package, 400 V SO package MM per JESD22-A115, and 1000 V CDM per JESD22-C101
- Latch-up free (bipolar process with no latching structures)
- Packages offered: DIP8, SO8 and TSSOP8

3. Applications

- Interface between I²C-buses operating at different logic levels (for example, 5 V and 3 V or 15 V)
- Interface between I²C-bus and SMBus (350 μ A) standard
- Simple conversion of I²C-bus SDA or SCL signals to multi-drop differential bus hardware, for example, via compatible PCA82C250
- Interfaces with opto-couplers to provide opto-isolation between I²C-bus nodes up to 400 kHz.

4. Ordering information

Table 1. Ordering information

Type number	Package		
	Name	Description	Version
P82B96DP	TSSOP8	plastic thin shrink small outline package; 8 leads; body width 3 mm	SOT505-1
P82B96PN	DIP8	plastic dual in-line package; 8 leads (300 mil)	SOT97-1
P82B96TD	SO8	plastic small outline package; 8 leads; body width 3.9 mm	SOT96-1
P82B96TD/S410	SO8	plastic small outline package; 8 leads; body width 3.9 mm	SOT96-1

4.1 Ordering options

Table 2. Ordering options

Type number	Topside mark	Temperature range
P82B96DP	82B96	-40 °C to +85 °C
P82B96PN	P82B96PN	-40 °C to +85 °C
P82B96TD	P82B96T	-40 °C to +85 °C
P82B96TD/S410	P82B96T	-40 °C to +125 °C

5. Block diagram

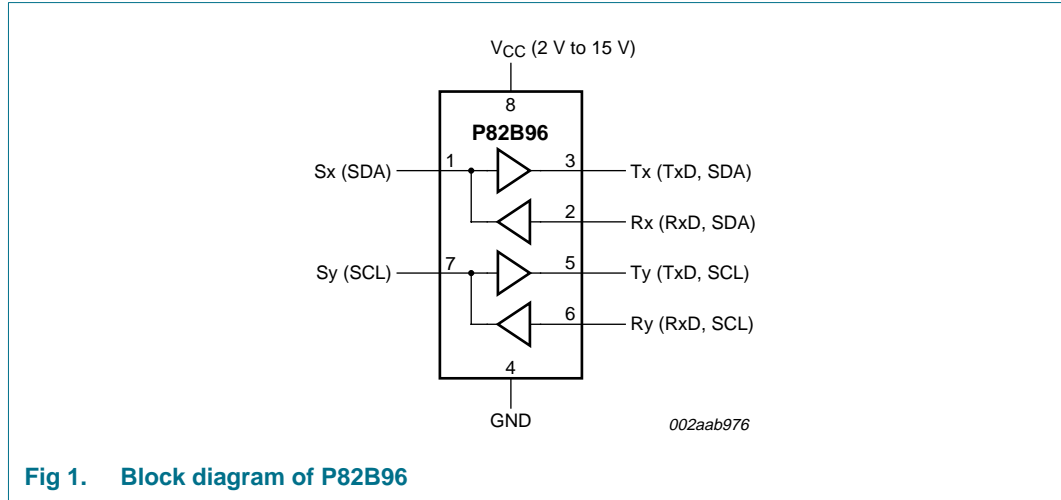

Fig 1. Block diagram of P82B96

6. Pinning information

6.1 Pinning

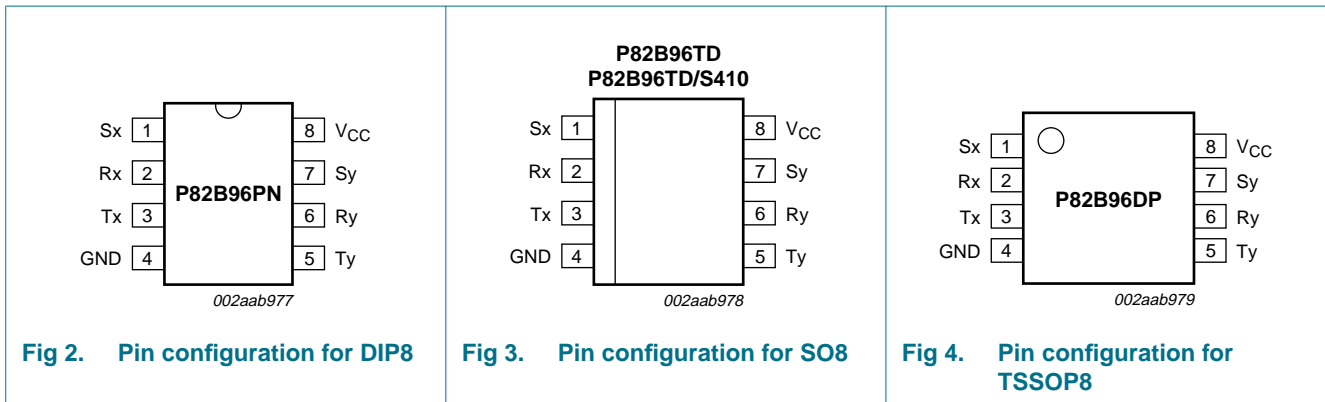

Fig 2. Pin configuration for DIP8

Fig 3. Pin configuration for SO8

Fig 4. Pin configuration for TSSOP8

6.2 Pin description

Table 3. Pin description

Symbol	Pin	Description
Sx	1	I ² C-bus (SDA or SCL)
Rx	2	receive signal
Tx	3	transmit signal
GND	4	negative supply
Ty	5	transmit signal
Ry	6	receive signal
Sy	7	I ² C-bus (SDA or SCL)
V _{CC}	8	positive supply voltage

7. Functional description

Refer to [Figure 1 “Block diagram of P82B96”](#).

The P82B96 has two identical buffers allowing buffering of both of the I²C-bus (SDA and SCL) signals. Each buffer is made up of two logic signal paths, a forward path from the I²C-bus interface pin which drives the buffered bus, and a reverse signal path from the buffered bus input to drive the I²C-bus interface. Thus these paths are:

- sense the voltage state of the I²C-bus pin S_x (or S_y) and transmit this state to the pin T_x (T_y respectively), and
- sense the state of the pin R_x (R_y) and pull the I²C-bus pin LOW whenever R_x (R_y) is LOW.

The rest of this discussion will address only the ‘x’ side of the buffer; the ‘y’ side is identical.

The I²C-bus pin (S_x) is designed to interface with a normal I²C-bus.

The logic threshold voltage levels on the I²C-bus are independent of the IC supply V_{CC}. The maximum I²C-bus supply voltage is 15 V and the guaranteed static sink current is 3 mA.

The logic level of R_x is determined from the power supply voltage V_{CC} of the chip. Logic LOW is below 42 % of V_{CC}, and logic HIGH is above 58 % of V_{CC} (with a typical switching threshold of half V_{CC}).

T_x is an open-collector output without ESD protection diodes to V_{CC}. It may be connected via a pull-up resistor to a supply voltage in excess of V_{CC}, as long as the 15 V rating is not exceeded. It has a larger current sinking capability than a normal I²C-bus device, being able to sink a static current of greater than 30 mA, and typical 100 mA dynamic pull-down capability as well.

A logic LOW is only transmitted to T_x when the voltage at the I²C-bus pin (S_x) is below 0.6 V. A logic LOW at R_x will cause the I²C-bus (S_x) to be pulled to a logic LOW level in accordance with I²C-bus requirements (maximum 1.5 V in 5 V applications) but not low enough to be looped back to the T_x output and cause the buffer to latch LOW.

The minimum LOW level this chip can achieve on the I²C-bus by a LOW at R_x is typically 0.8 V.

If the supply voltage V_{CC} fails, then neither the I²C-bus nor the T_x output will be held LOW. Their open-collector configuration allows them to be pulled up to the rated maximum of 15 V even without V_{CC} present. The input configuration on S_x and R_x also present no loading of external signals even when V_{CC} is not present.

The effective input capacitance of any signal pin, measured by its effect on bus rise times, is less than 7 pF for all bus voltages and supply voltages including V_{CC} = 0 V.

Remark: Two or more S_x or S_y I/Os must not be interconnected. The P82B96 design does not support this configuration. Bidirectional I²C-bus signals do not allow any direction control pin so, instead, slightly different logic low voltage levels are used at S_x/S_y to avoid latching of this buffer. A ‘regular I²C-bus LOW’ applied at the R_x/R_y of a P82B96 will be propagated to S_x/S_y as a ‘buffered LOW’ with a slightly higher voltage level. If this

special 'buffered LOW' is applied to the Sx/Sy of another P82B96 that second P82B96 will not recognize it as a 'regular I²C-bus LOW' and will not propagate it to its Tx/Ty output. The Sx/Sy side of P82B96 may not be connected to similar buffers that rely on special logic thresholds for their operation, for example PCA9511, PCA9515, or PCA9518. The Sx/Sy side is only intended for, and compatible with, the normal I²C-bus logic voltage levels of I²C-bus master and slave chips, or even Tx/Rx signals of a second P82B96 if required. The Tx/Rx and Ty/Ry I/O pins use the standard I²C-bus logic voltage levels of all I²C-bus parts. There are **no** restrictions on the interconnection of the Tx/Rx and Ty/Ry I/O pins to other P82B96s, for example in a star or multipoint configuration with the Tx/Rx and Ty/Ry I/O pins on the common bus and the Sx/Sy side connected to the line card slave devices. For more details see *Application Note AN255*.

8. Limiting values

Table 4. Limiting values

*In accordance with the Absolute Maximum Rating System (IEC 60134).
Voltages with respect to pin GND.*

Symbol	Parameter	Conditions	Min	Max	Unit
V _{CC}	supply voltage	V _{CC} to GND	-0.3	+18	V
V _{Sx}	voltage on pin Sx	I ² C-bus SDA or SCL	-0.3	+18	V
V _{Tx}	voltage on pin Tx	buffered output	-0.3	+18	V
V _{Rx}	voltage on pin Rx	receive input	-0.3	+18	V
I _n	current on any pin		-	250	mA
P _{tot}	total power dissipation		-	300	mW
T _j	junction temperature	operating range P82B96TD/S410	-40	+125	°C
T _{stg}	storage temperature		-55	+125	°C
T _{amb}	ambient temperature	operating	-40	+85	°C

9. Characteristics

Table 5. Characteristics

$T_{amb} = +25\text{ °C}$; voltages are specified with respect to GND with $V_{CC} = 5\text{ V}$, unless otherwise specified.

Symbol	Parameter	Conditions	$T_{amb} = +25\text{ °C}$			$T_{amb} = -40\text{ °C to }+125\text{ °C}$ ^[1]		Unit
			Min	Typ	Max	Min	Max	
Power supply								
V_{CC}	supply voltage	operating	2.0	-	15	2.0	15	V
I_{CC}	supply current	buses HIGH	-	0.9	1.8	-	3	mA
		$V_{CC} = 15\text{ V}$; buses HIGH	-	1.1	2.5	-	4	mA
ΔI_{CC}	additional quiescent supply current	per Tx or Ty LOW	-	1.7	3.5	-	3.5	mA
Bus pull-up (load) voltages and currents								
V_{Sx}, V_{Sy}	maximum input/output voltage	open-collector; I ² C-bus and $V_{Rx}, V_{Ry} = \text{HIGH}$	-	-	15	-	15	V
I_{Sx}, I_{Sy}	static output loading on I ² C-bus	$V_{Sx}, V_{Sy} = 1.0\text{ V}$; $V_{Rx}, V_{Ry} = \text{LOW}$	^[2] 0.2	-	3	0.2	3	mA
I_{Sx}, I_{Sy}	dynamic output sink capability on I ² C-bus	$V_{Sx}, V_{Sy} = 2\text{ V}$; $V_{Rx}, V_{Ry} = \text{LOW}$	7	18	-	7	-	mA
I_{Sx}, I_{Sy}	leakage current on I ² C-bus	$V_{Sx}, V_{Sy} = 5\text{ V}$; $V_{Rx}, V_{Ry} = \text{HIGH}$	-	-	1	-	10	μA
		$V_{Sx}, V_{Sy} = 15\text{ V}$; $V_{Rx}, V_{Ry} = \text{HIGH}$	-	1	-	-	10	μA
V_{Tx}, V_{Ty}	maximum output voltage level	open-collector	-	-	15	-	15	V
I_{Tx}, I_{Ty}	static output loading on buffered bus	$V_{Tx}, V_{Ty} = 0.4\text{ V}$; $V_{Sx}, V_{Sy} = \text{LOW}$ on I ² C-bus = 0.4 V	-	-	30	-	30	mA
I_{Tx}, I_{Ty}	dynamic output sink capability, buffered bus	$V_{Tx}, V_{Ty} > 1\text{ V}$; $V_{Sx}, V_{Sy} = \text{LOW}$ on I ² C-bus = 0.4 V	60	100	-	60	-	mA
I_{Tx}, I_{Ty}	leakage current on buffered bus	$V_{Tx}, V_{Ty} = V_{CC} = 15\text{ V}$; $V_{Sx}, V_{Sy} = \text{HIGH}$	-	1	-	-	10	μA
Input currents								
I_{Sx}, I_{Sy}	input current from I ² C-bus	bus LOW; $V_{Rx}, V_{Ry} = \text{HIGH}$	-	-1	-	-	-10	μA
I_{Rx}, I_{Ry}	input current from buffered bus	bus LOW; $V_{Rx}, V_{Ry} = 0.4\text{ V}$	-	-1	-	-	-10	μA
I_{Rx}, I_{Ry}	leakage current on buffered bus input	$V_{Rx}, V_{Ry} = V_{CC}$	-	1	-	-	10	μA
Output logic LOW level								
V_{Sx}, V_{Sy}	output logic level LOW on normal I ² C-bus	$I_{Sx}, I_{Sy} = 3\text{ mA}$	^[3] 0.8	0.88	1.0	(see Figure 6)		V
		$I_{Sx}, I_{Sy} = 0.2\text{ mA}$	^[3] 670	730	790	(see Figure 5)		mV
$dV_{Sx}/dT, dV_{Sy}/dT$	temperature coefficient of output LOW levels	$I_{Sx}, I_{Sy} = 0.2\text{ mA}$	^[3] -	-1.8	-	-	-	mV/K

Table 5. Characteristics ...continued

$T_{amb} = +25\text{ }^{\circ}\text{C}$; voltages are specified with respect to GND with $V_{CC} = 5\text{ V}$, unless otherwise specified.

Symbol	Parameter	Conditions	$T_{amb} = +25\text{ }^{\circ}\text{C}$			$T_{amb} = -40\text{ }^{\circ}\text{C}$ to $+125\text{ }^{\circ}\text{C}$ ^[1]		Unit	
			Min	Typ	Max	Min	Max		
Input logic switching threshold voltages									
V_{Sx}, V_{Sy}	input logic voltage LOW	on normal I ² C-bus	[4]	-	640	600	(see Figure 7)	mV	
V_{Sx}, V_{Sy}	input logic level HIGH threshold	on normal I ² C-bus	[4]	700	650	-	(see Figure 8)	mV	
$dV_{Sx}/dT, dV_{Sy}/dT$	temperature coefficient of input thresholds			-	-2	-	-	mV/K	
V_{Rx}, V_{Ry}	input logic HIGH level	fraction of applied V_{CC}		$0.58V_{CC}$	-	-	$0.58V_{CC}$	V	
V_{Rx}, V_{Ry}	input threshold	fraction of applied V_{CC}		-	$0.5V_{CC}$	-	-	V	
V_{Rx}, V_{Ry}	input logic LOW level	fraction of applied V_{CC}		-	-	$0.42V_{CC}$	-	$0.42V_{CC}$	
Logic level threshold difference									
V_{Sx}, V_{Sy}	input/output logic level difference	V_{Sx} output LOW at 0.2 mA – V_{Sx} input HIGH maximum	[2]	50	85	-	50	-	mV
Thermal resistance									
$R_{th(j-pcb)}$	thermal resistance from junction to printed-circuit board	SOT96-1 (SO8); average lead temperature at board interface		-	127	-	-	-	K/W
Bus release on V_{CC} failure									
$V_{Sx}, V_{Sy}, V_{Tx}, V_{Ty}$	V_{CC} voltage at which all buses are guaranteed to be released			-	-	1	(see Figure 9)	V	
dV/dT	temperature coefficient of guaranteed release voltage			-	-4	-	-	-	mV/K
Buffer response time^[5]									
$T_{fall\ delay}$ V_{Sx} to V_{Tx}, V_{Sy} to V_{Ty}	buffer time delay on falling input between V_{Sx} = input switching threshold, and V_{Tx} output falling 50 %	R_{Tx} pull-up = 160 Ω ; no capacitive load; $V_{CC} = 5\text{ V}$		-	70	-	-	-	ns
$T_{rise\ delay}$ V_{Sx} to V_{Tx}, V_{Sy} to V_{Ty}	buffer time delay on rising input between V_{Sx} = input switching threshold, and V_{Tx} output reaching 50 % V_{CC}	R_{Tx} pull-up = 160 Ω ; no capacitive load; $V_{CC} = 5\text{ V}$		-	90	-	-	-	ns

Table 5. Characteristics ...continued

$T_{amb} = +25\text{ }^{\circ}\text{C}$; voltages are specified with respect to GND with $V_{CC} = 5\text{ V}$, unless otherwise specified.

Symbol	Parameter	Conditions	$T_{amb} = +25\text{ }^{\circ}\text{C}$			$T_{amb} = -40\text{ }^{\circ}\text{C}$ to $+125\text{ }^{\circ}\text{C}$ ^[1]		Unit
			Min	Typ	Max	Min	Max	
T_{fall} delay V_{Rx} to V_{Sx} , V_{Ry} to V_{Sy}	buffer time delay on falling input between $V_{Rx} =$ input switching threshold, and V_{Sx} output falling 50 %	R_{Sx} pull-up = 1500 Ω ; no capacitive load; $V_{CC} = 5\text{ V}$	-	250	-	-	-	ns
T_{rise} delay V_{Rx} to V_{Sx} , V_{Ry} to V_{Sy}	buffer time delay on rising input between $V_{Rx} =$ input switching threshold, and V_{Sx} output reaching 50 % V_{CC}	R_{Sx} pull-up = 1500 Ω ; no capacitive load; $V_{CC} = 5\text{ V}$	-	270	-	-	-	ns
Input capacitance								
C_i	input capacitance	effective input capacitance of any signal pin measured by incremental bus rise times	-	-	7	-	7	pF

- [1] Limit data for +125 °C applies to P82B96TD/S410 version. It is guaranteed by design/characterization, but not by 100 % test.
- [2] The minimum value requirement for pull-up current, 200 μA , guarantees that the minimum value for V_{Sx} output LOW will always exceed the minimum V_{Sx} input HIGH level to eliminate any possibility of latching. The specified difference is guaranteed by design within any IC. While the tolerances on absolute levels allow a small probability the LOW from one Sx output is recognized by an Sx input of another P82B96, this has no consequences for normal applications. In any design the Sx pins of different ICs should never be linked because the resulting system would be very susceptible to induced noise and would not support all I²C-bus operating modes.
- [3] The output logic LOW depends on the sink current. For scaling, see *Application Note AN255*.
- [4] The input logic threshold is independent of the supply voltage.
- [5] The fall time of V_{Tx} from 5 V to 2.5 V in the test is approximately 15 ns.
The fall time of V_{Sx} from 5 V to 2.5 V in the test is approximately 50 ns.
The rise time of V_{Tx} from 0 V to 2.5 V in the test is approximately 20 ns.
The rise time of V_{Sx} from 0.9 V to 2.5 V in the test is approximately 70 ns.

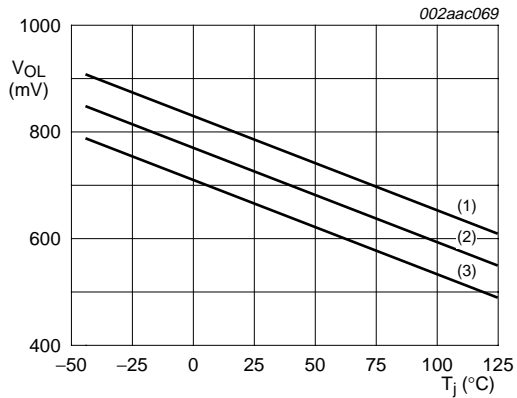

V_{OL} at S_x typical and limits over temperature
 (1) Maximum
 (2) Typical
 (3) Minimum

Fig 5. V_{OL} as a function of junction temperature ($I_{OL} = 0.2$ mA)

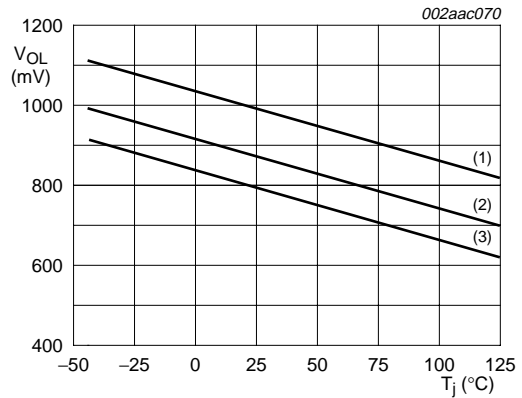

V_{OL} at S_x typical and limits over temperature
 (1) Maximum
 (2) Typical
 (3) Minimum

Fig 6. V_{OL} as a function of junction temperature ($I_{OL} = 3$ mA)

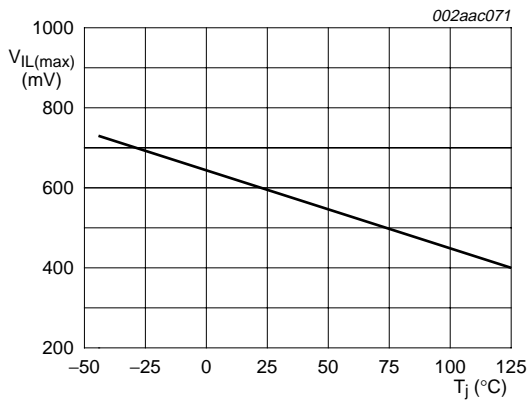

$V_{IL(max)}$ at S_x changes over temperature range

Fig 7. $V_{IL(max)}$ as a function of junction temperature

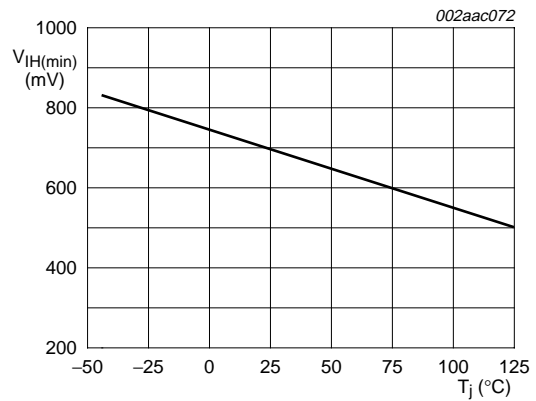

$V_{IH(min)}$ at S_x changes over temperature range.

Fig 8. $V_{IH(min)}$ as a function of junction temperature

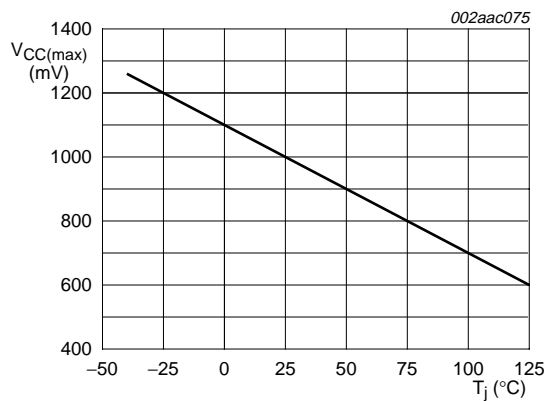

Fig 9. $V_{CC(max)}$ that guarantees bus release limit over temperature

10. Application information

Refer to AN460 and AN255 for more application detail.

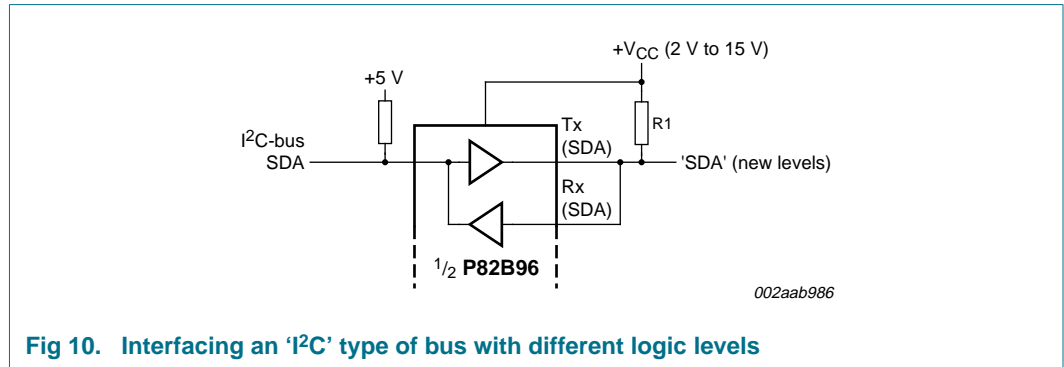

Fig 10. Interfacing an 'I²C' type of bus with different logic levels

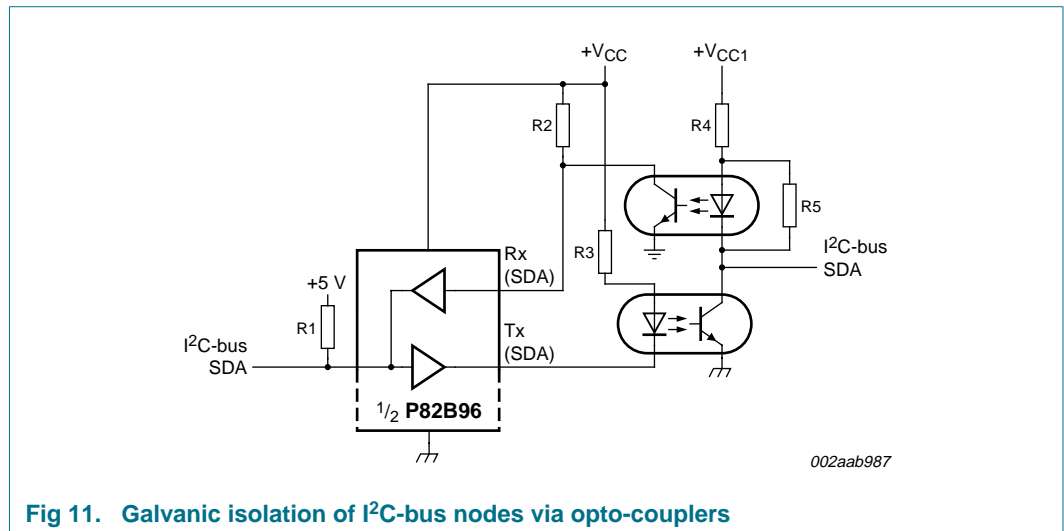

Fig 11. Galvanic isolation of I²C-bus nodes via opto-couplers

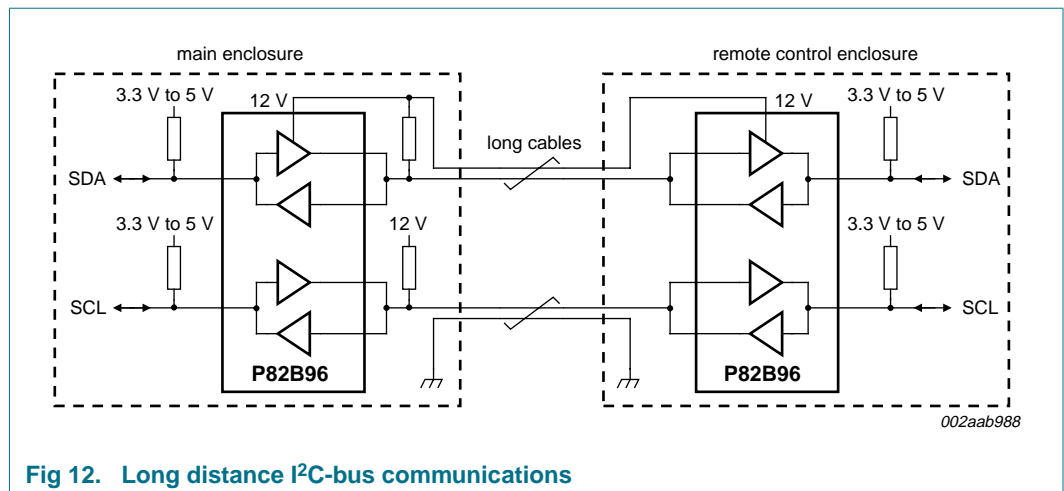
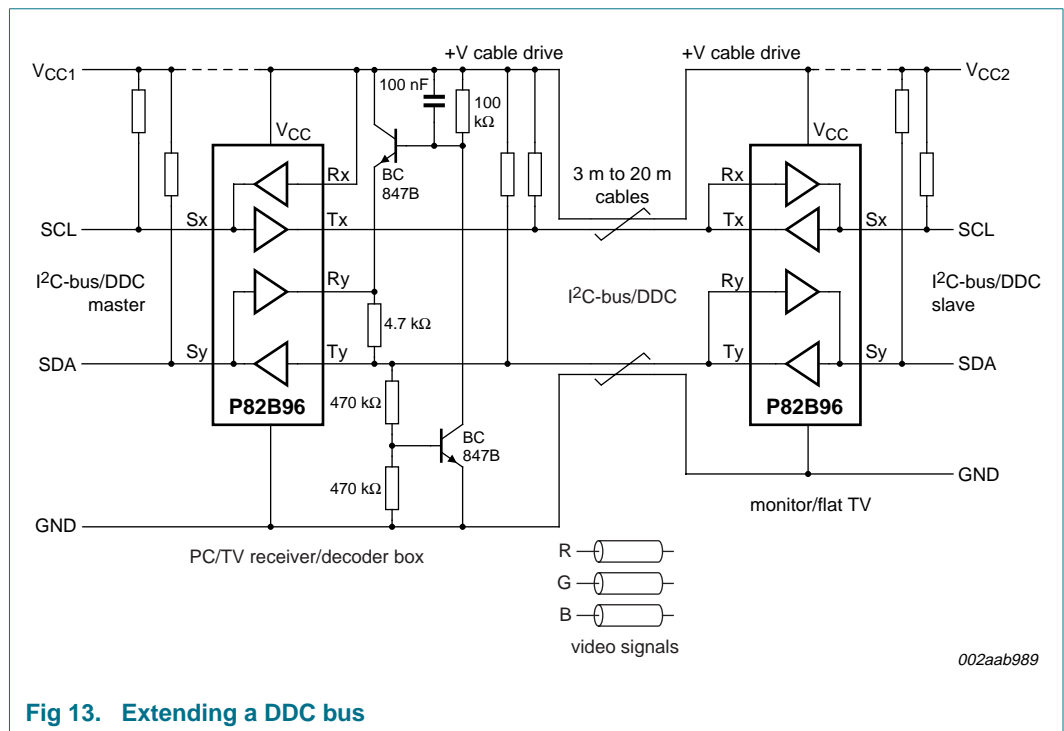

Fig 12. Long distance I²C-bus communications

Figure 13 shows how a master I²C-bus can be protected against short circuits or failures in applications that involve plug and socket connections and long cables that may become damaged. A simple circuit is added to monitor the SDA bus, and if its LOW time exceeds the design value, then the master bus is disconnected. P82B96 will free all its I/Os if its supply is removed, so one option is to connect its V_{CC} to the output of a logic gate from, say, the 74LVC family. The SDA and SCL lines could be timed and V_{CC} disabled via the gate if one or other lines exceeds a design value of 'LOW' period as in Figure 28 of AN255. If the supply voltage of logic gates restricts the choice of V_{CC} supply then the low-cost discrete circuit in Figure 13 can be used. If the SDA line is held LOW, the 100 nF capacitor will charge and the Ry input will be pulled towards V_{CC}. When it exceeds 0.5V_{CC} the Ry input will set the Sy input HIGH, which in practice means simply releasing it.

In this example the SCL line is made unidirectional by tying the Rx pin to V_{CC}. The state of the buffered SCL line cannot affect the master clock line which is allowed when clock-stretching is not required. It is simple to add an additional transistor or diode to control the Rx input in the same way as Ry when necessary. The +V cable drive can be any voltage up to 15 V and the bus may be run at a lower impedance by selecting pull-up resistors for a static sink current up to 30 mA. V_{CC1} and V_{CC2} may be chosen to suit the connected devices. Because DDC uses relatively low speeds (< 100 kHz), the cable length is not restricted to 20 m by the I²C-bus signalling, but it may be limited by the video signalling.



[Figure 14](#) shows that P82B96 can achieve high clock rates over long cables. While calculating with lumped wiring capacitance yields reasonable approximations to actual timing, even 25 meters of cable is better treated using transmission line theory. Flat ribbon cables connected as shown, with the bus signals on the outer edge, will have a characteristic impedance in the range 100 Ω to 200 Ω . For simplicity they cannot be terminated in their characteristic impedance but a practical compromise is to use the minimum pull-up allowed for P82B96 and place half this termination at each end of the cable. When each pull-up is below 330 Ω , the rising edge waveforms have their first voltage 'step' level above the logic threshold at Rx and cable timing calculations can be based on the fast rise/fall times of resistive loading plus simple one-way propagation delays. When the pull-up is larger, but below 750 Ω , the threshold at Rx will be crossed after one signal reflection. So at the sending end it is crossed after 2 times the one-way propagation delay and at the receiving end after 3 times that propagation delay. For flat cables with partial plastic dielectric insulation (by using outer cores) the one-way propagation delays will be about 5 ns per meter. The 10 % to 90 % rise and fall times on the cable will be between 20 ns and 50 ns, so their delay contributions are small. There will be ringing on falling edges that can be damped, if required, by using Schottky diodes as shown.

When the Master SCL HIGH and LOW periods can be programmed separately, for example using control registers I2SCLH and I2SCLL of 89LPC932, the timings can allow for bus delays. The LOW period should be programmed to achieve the minimum 1300 ns plus the net delay in the slave's response data signal caused by bus and buffer delays. The longest data delay is the sum of the delay of the falling edge of SCL from master to slave and the delay of the rising edge of SDA from slave data to master. Because the buffer will 'stretch' the programmed SCL LOW period, the actual SCL frequency will be lower than calculated from the programmed clock periods. In the example for 25 meters the clock is stretched 400 ns, the falling edge of SCL is delayed 490 ns and the SDA rising edge is delayed 570 ns. The required additional LOW period is $(490 \text{ ns} + 570 \text{ ns}) = 1060 \text{ ns}$ and the I²C-bus specifications already include an allowance for a worst case bus rise time 0 % to 70 % of 425 ns. (The bus rise time can be 300 ns 30 % to 70 %, which means it can be 425 ns 0 % to 70 %. The 25 meter cable delay times as quoted already include all rise and fall times.) Therefore, the microcontroller only needs to be programmed with an additional $(1060 \text{ ns} - 400 \text{ ns} - 425 \text{ ns}) = 235 \text{ ns}$, making a total programmed LOW period 1535 ns. The programmed LOW will be stretched by 400 ns to yield an actual bus LOW time of 1935 ns, which, allowing the minimum HIGH period of 600 ns, yields a cycle period of 2535 ns or 394 kHz.

Note that in both the 100 meter and 250 meter examples, the capacitive loading on the I²C-buses at each end is within the maximum allowed Standard mode loading of 400 pF, but exceeds the Fast mode limit. This is an example of a 'hybrid' mode because it relies on the response delays of Fast mode parts but uses (allowable) Standard mode bus loadings with rise times that contribute significantly to the system delays. The cables cause large propagation delays, so these systems need to operate well below the 400 kHz limit, but illustrate how they can still exceed the 100 kHz limit provided all parts are capable of Fast mode operation. The fastest example illustrates how the 400 kHz limit can be exceeded, provided masters and slaves have the required timings, namely smaller than the maximum allowed for Fast mode. Many NXP slaves have delays shorter than 600 ns and all Fm+ devices must be < 450 ns.

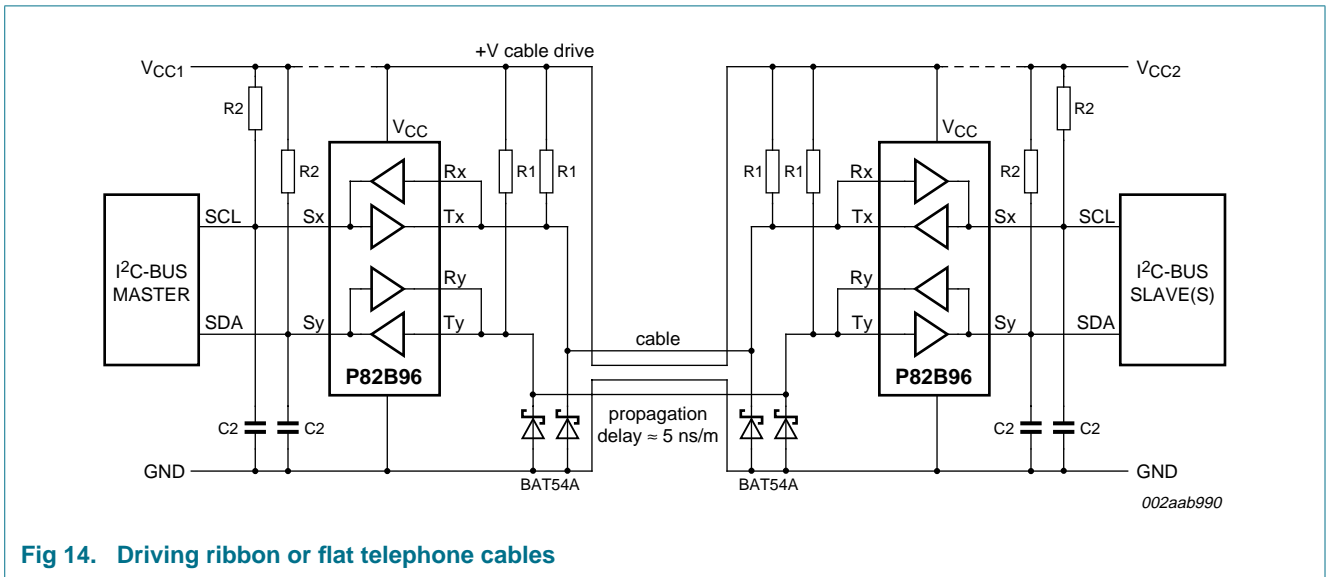
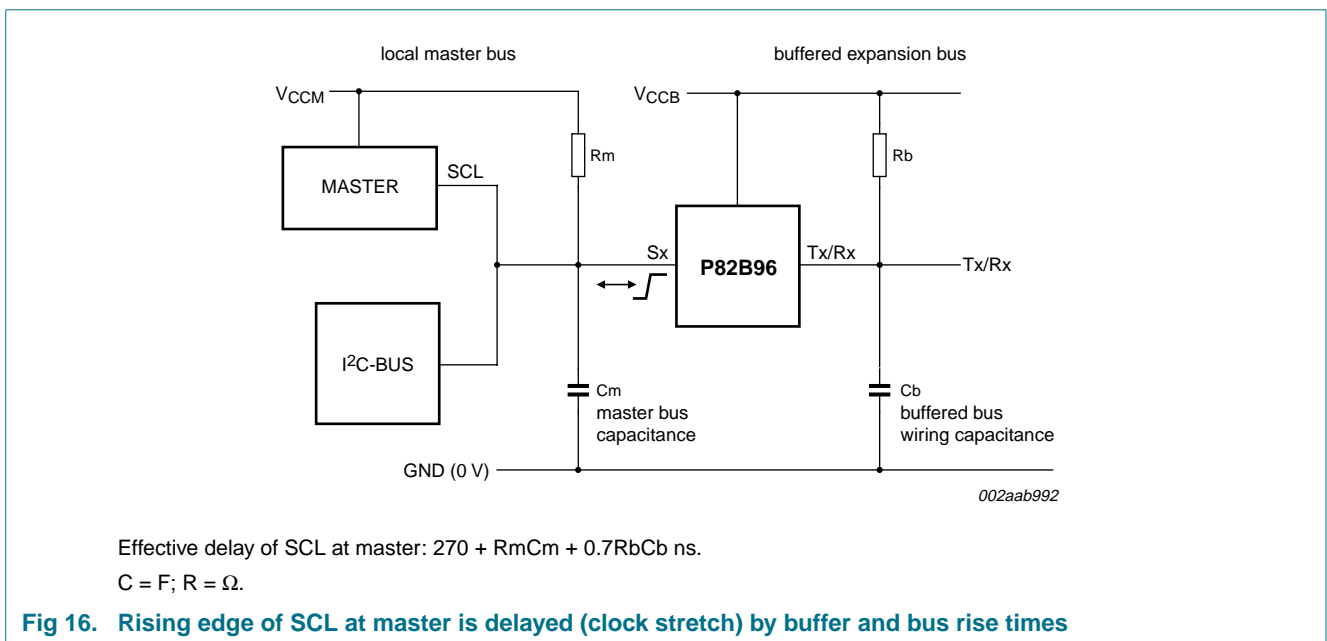
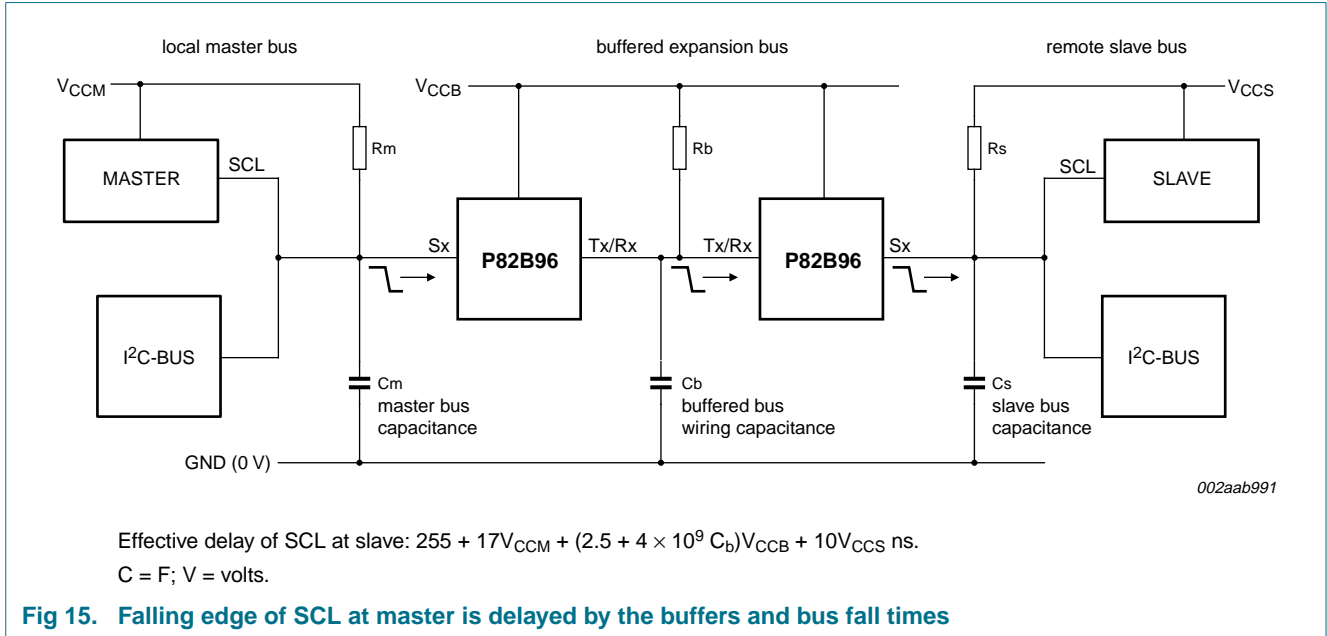

Fig 14. Driving ribbon or flat telephone cables

Table 6. Examples of bus capabilityRefer to [Figure 14](#).

+V _{CC1}	+V cable	+V _{CC2}	R1 (Ω)	R2 (Ω)	C2 (pF)	Cable length	Cable capacitance	Cable delay	Set master nominal SCL		Effective bus clock speed	Maximum slave response delay
									HIGH period	LOW period		
5 V	12 V	5 V	750	2.2 k	400	250 m	n/a (delay based)	1.25 μs	600 ns	4000 ns	120 kHz	Normal spec. 400 kHz parts
5 V	12 V	5 V	750	2.2 k	220	100 m	n/a (delay based)	500 ns	600 ns	2600 ns	185 kHz	Normal spec. 400 kHz parts
3.3 V	5 V	3.3 V	330	1 k	220	25 m	1 nF	125 ns	600 ns	1500 ns	390 kHz	Normal spec. 400 kHz parts
3.3 V	5 V	3.3 V	330	1 k	100	3 m	120 pF	15 ns	600 ns	1000 ns	500 kHz	600 ns

10.1 Calculating system delays and bus clock frequency for a Fast mode system



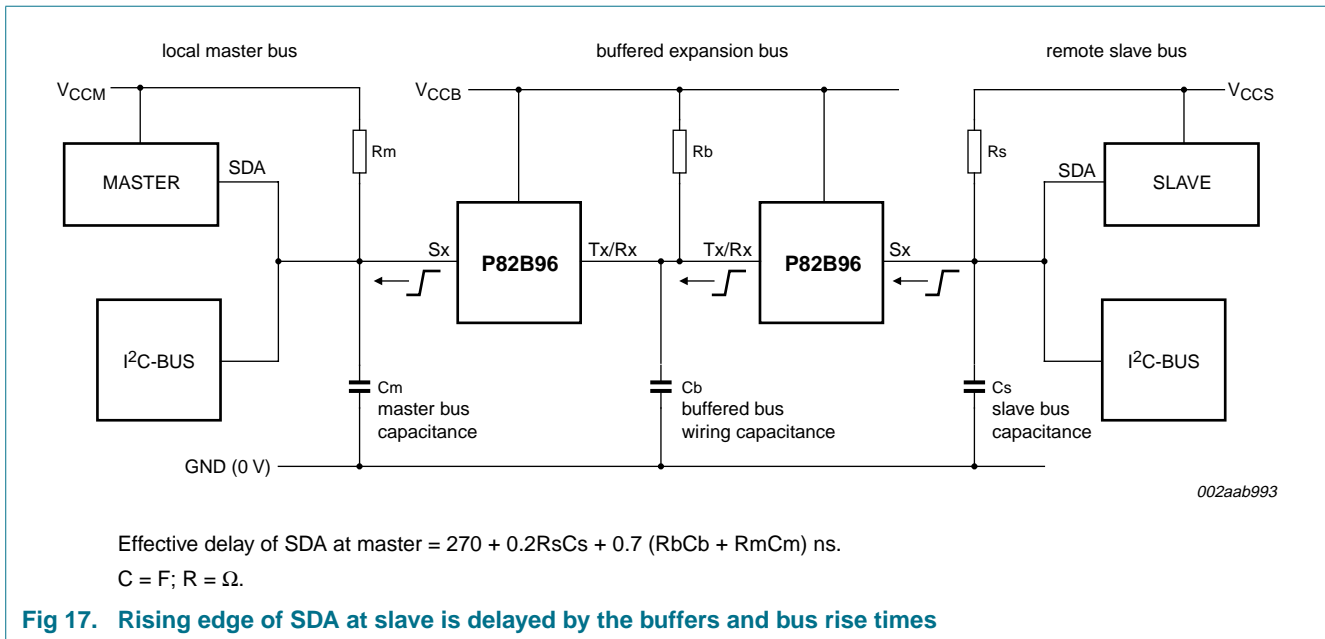

Figure 15, Figure 16, and Figure 17 show the P82B96 used to drive extended bus wiring, with relatively large capacitance, linking two Fast mode I²C-bus nodes. It includes simplified expressions for making the relevant timing calculations for 3.3 V or 5 V operation. Because the buffers and the wiring introduce timing delays, it may be necessary to decrease the nominal SCL frequency below 400 kHz. In most cases the actual bus frequency will be lower than the nominal Master timing due to bit-wise stretching of the clock periods.

The delay factors involved in calculation of the allowed bus speed are:

- A** — The propagation delay of the master signal through the buffers and wiring to the slave. The important delay is that of the falling edge of SCL because this edge ‘requests’ the data or acknowledgment from a slave. See Figure 15.
- B** — The effective stretching of the nominal LOW period of SCL at the master caused by the buffer and bus rise times. See Figure 16.
- C** — The propagation delay of the slave’s response signal through the buffers and wiring back to the master. The important delay is that of a rising edge in the SDA signal. Rising edges are always slower and are therefore delayed by a longer time than falling edges. (The rising edges are limited by the passive pull-up while falling edges are actively driven). See Figure 17.

The timing requirement in any I²C-bus system is that a slave’s data response (which is provided in response to a falling edge of SCL) must be received at the master before the end of the corresponding LOW period of SCL as appears on the bus wiring at the master. Since all slaves will, as a minimum, satisfy the worst case timing requirements of a 400 kHz part, they must provide their response within the minimum allowed clock LOW period of 1300 ns. Therefore in systems that introduce additional delays it is only necessary to extend that minimum clock LOW period by any ‘effective’ delay of the slave’s response. The effective delay of the slave’s response equals the total delays in SCL falling

edge from the master reaching the slave (Figure 15) minus the effective delay (stretch) of the SCL rising edge (Figure 16) plus total delays in the slave's response data, carried on SDA, reaching the master (Figure 17).

The master microcontroller should be programmed to produce a nominal SCL LOW period = $(1300 + A - B + C)$ ns, and should be programmed to produce the nominal minimum SCL HIGH period of 600 ns. Then a check should be made to ensure the cycle time is not shorter than the minimum 2500 ns. If found necessary, just increase either clock period.

Due to clock stretching, the SCL cycle time will always be longer than $(600 + 1300 + A + C)$ ns.

Example:

The master bus has an $RmCm$ product of 100 ns and $V_{CCM} = 5$ V.

The buffered bus has a capacitance of 1 nF and a pull-up resistor of 160 Ω to 5 V giving an $RbCb$ product of 160 ns. The slave bus also has an $RcCs$ product of 100 ns.

The microcontroller LOW period should be programmed to $\geq (1300 + 372.5 - 482 + 472)$ ns, that is ≥ 1662.5 ns.

Its HIGH period may be programmed to the minimum 600 ns.

The nominal microcontroller clock period will be $\geq (1662.5 + 600)$ ns = 2262.5 ns, equivalent to a frequency of 442 kHz.

The actual bus clock period, including the 482 ns clock stretch effect, will be below (nominal + stretch) = $(2262.5 + 482)$ ns or ≥ 2745 ns, equivalent to an allowable frequency of 364 kHz.

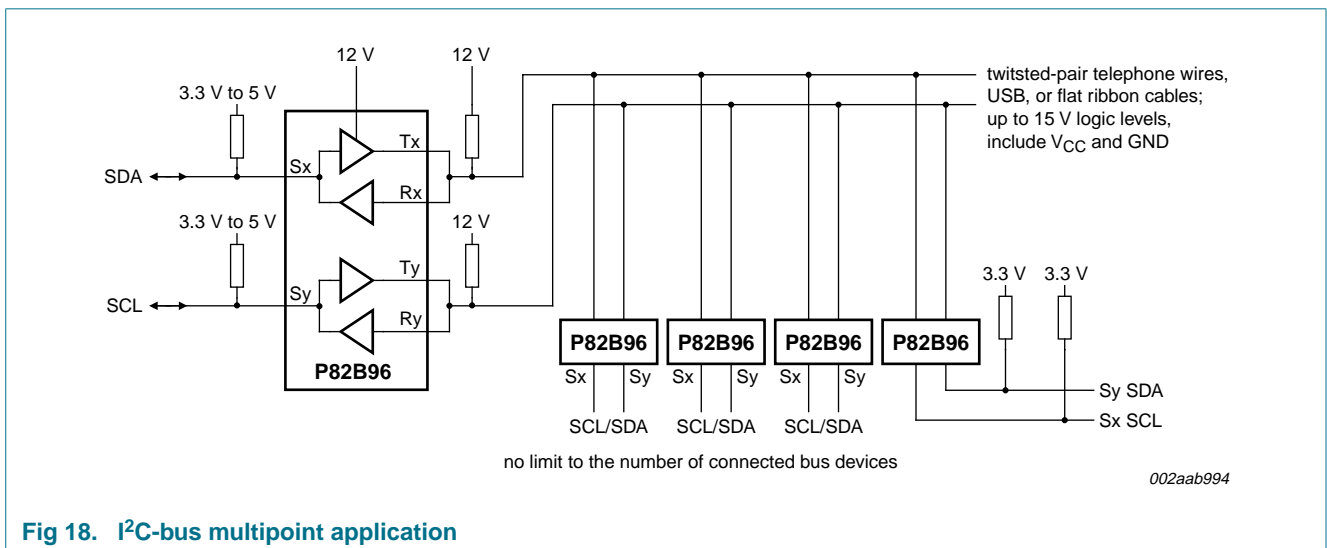
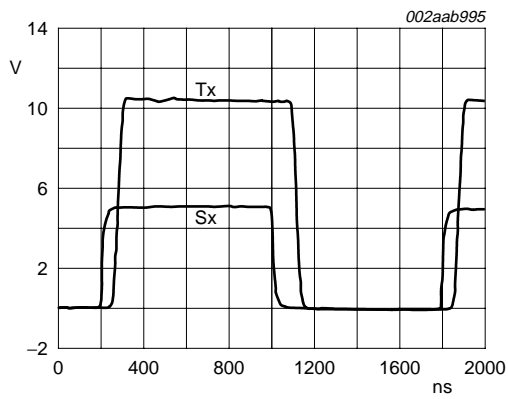
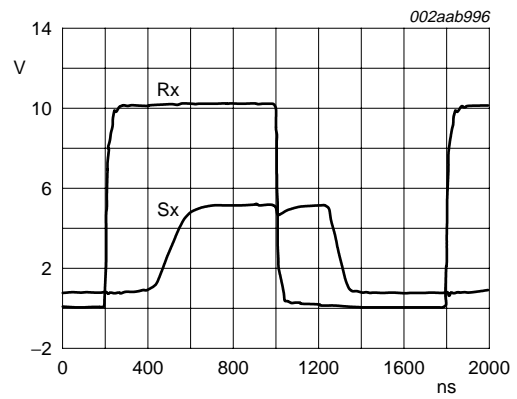

Fig 18. I²C-bus multipoint application



frequency = 624 kHz

Fig 19. Propagation Sx to Tx (Sx pull-up to 5 V; Tx pull-up to V_{CC} = 10 V)



ch1 frequency = 624 kHz

Fig 20. Propagation Rx to Sx (Sx pull-up to 5 V; Rx pull-up to V_{CC} = 10 V)

11. Package outline

DIP8: plastic dual in-line package; 8 leads (300 mil)

SOT97-1

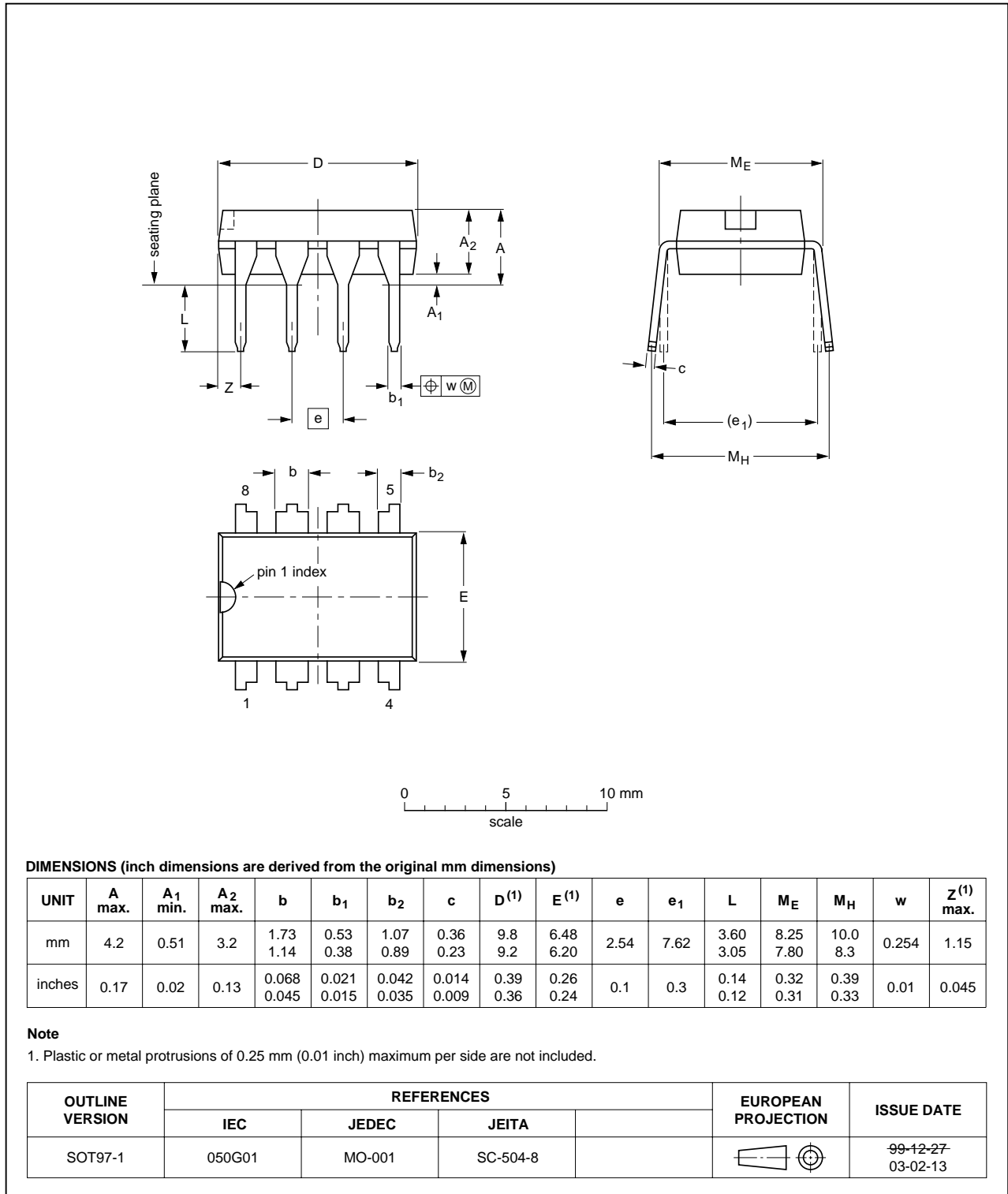

Fig 21. Package outline SOT97-1 (DIP8)

SO8: plastic small outline package; 8 leads; body width 3.9 mm

SOT96-1

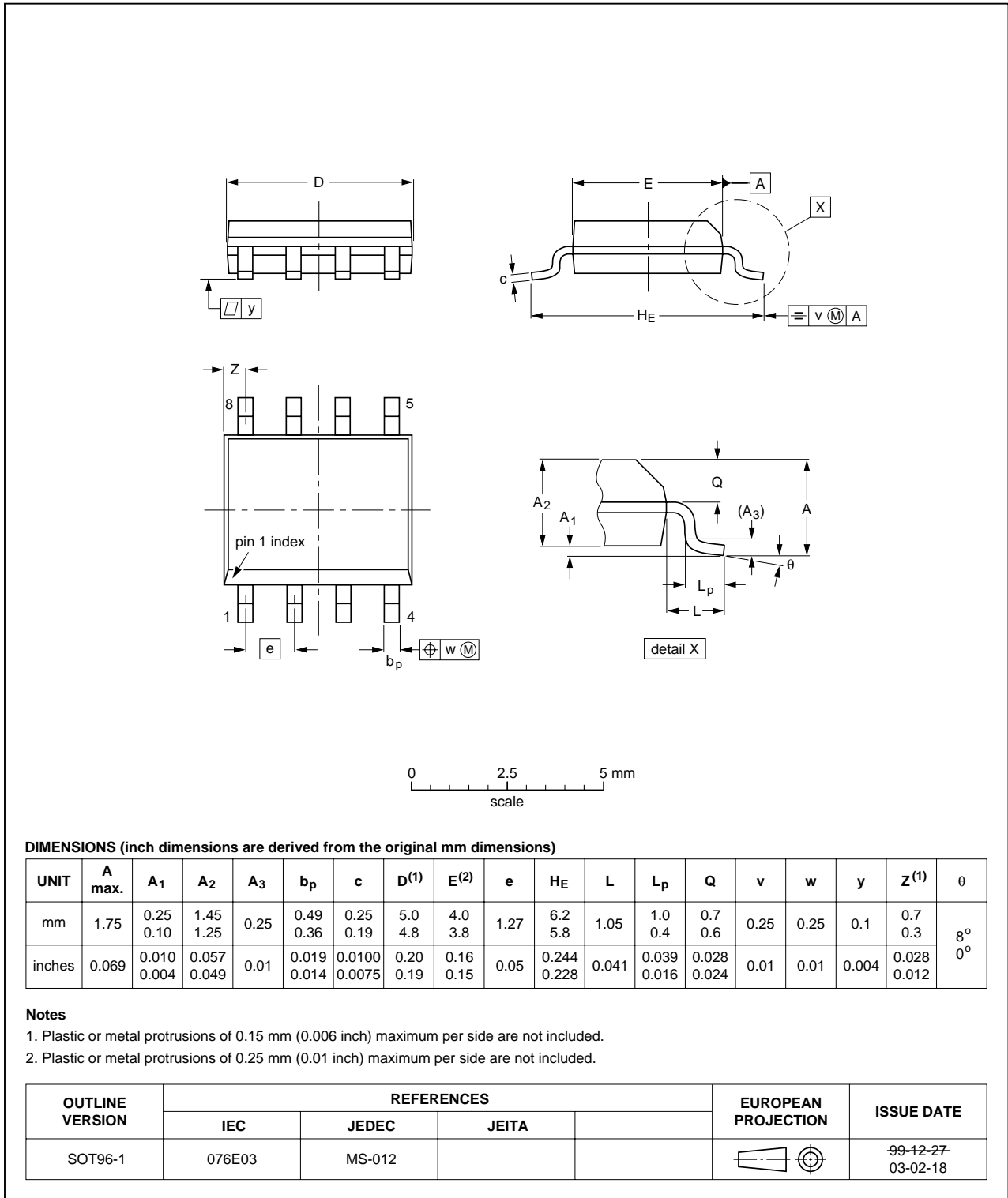

Fig 22. Package outline SOT96-1 (SO8)

TSSOP8: plastic thin shrink small outline package; 8 leads; body width 3 mm

SOT505-1

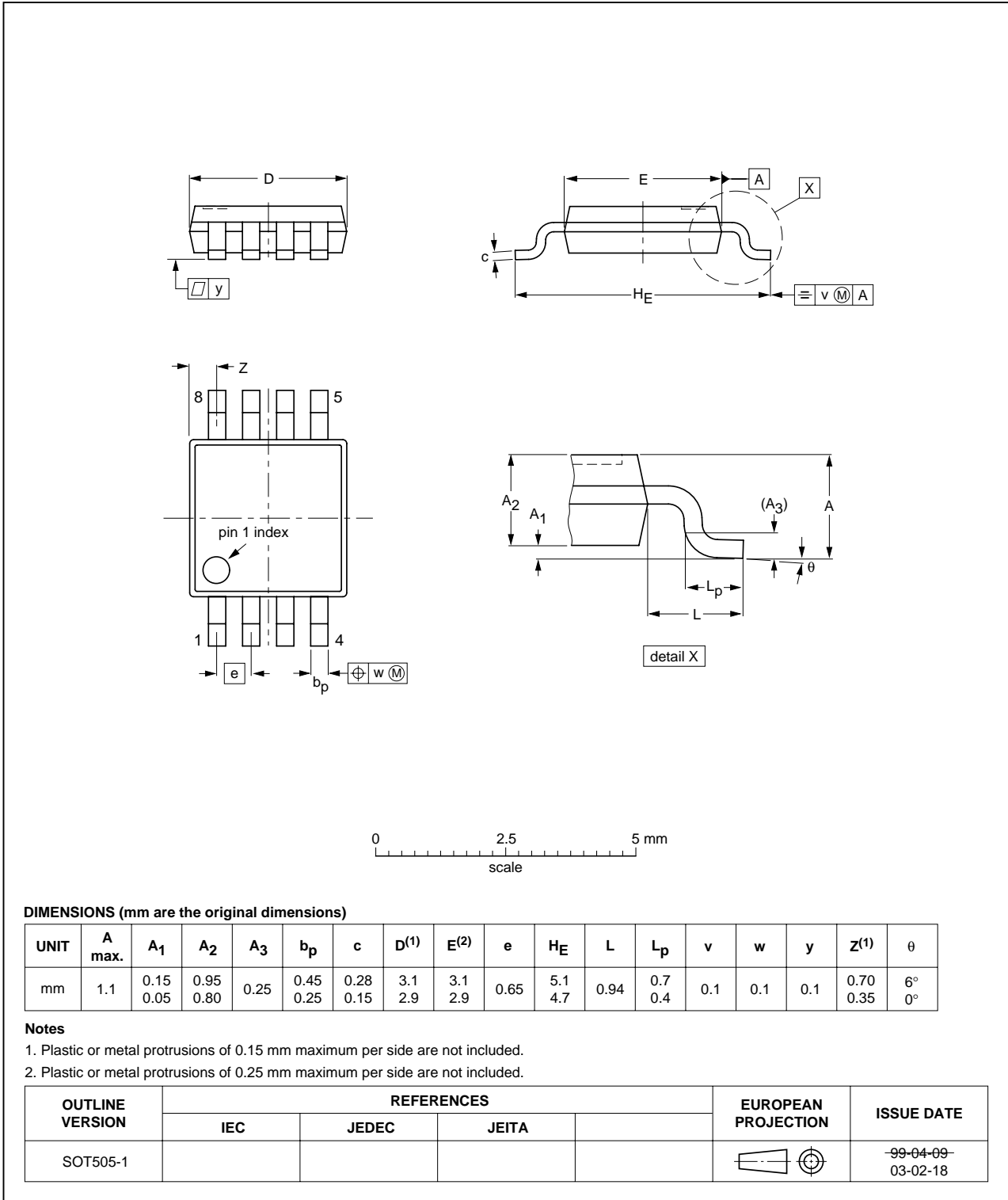

Fig 23. Package outline SOT505-1 (TSSOP8)

12. Soldering of SMD packages

This text provides a very brief insight into a complex technology. A more in-depth account of soldering ICs can be found in Application Note *AN10365 "Surface mount reflow soldering description"*.

12.1 Introduction to soldering

Soldering is one of the most common methods through which packages are attached to Printed Circuit Boards (PCBs), to form electrical circuits. The soldered joint provides both the mechanical and the electrical connection. There is no single soldering method that is ideal for all IC packages. Wave soldering is often preferred when through-hole and Surface Mount Devices (SMDs) are mixed on one printed wiring board; however, it is not suitable for fine pitch SMDs. Reflow soldering is ideal for the small pitches and high densities that come with increased miniaturization.

12.2 Wave and reflow soldering

Wave soldering is a joining technology in which the joints are made by solder coming from a standing wave of liquid solder. The wave soldering process is suitable for the following:

- Through-hole components
- Leaded or leadless SMDs, which are glued to the surface of the printed circuit board

Not all SMDs can be wave soldered. Packages with solder balls, and some leadless packages which have solder lands underneath the body, cannot be wave soldered. Also, leaded SMDs with leads having a pitch smaller than ~0.6 mm cannot be wave soldered, due to an increased probability of bridging.

The reflow soldering process involves applying solder paste to a board, followed by component placement and exposure to a temperature profile. Leaded packages, packages with solder balls, and leadless packages are all reflow solderable.

Key characteristics in both wave and reflow soldering are:

- Board specifications, including the board finish, solder masks and vias
- Package footprints, including solder thieves and orientation
- The moisture sensitivity level of the packages
- Package placement
- Inspection and repair
- Lead-free soldering versus SnPb soldering

12.3 Wave soldering

Key characteristics in wave soldering are:

- Process issues, such as application of adhesive and flux, clinching of leads, board transport, the solder wave parameters, and the time during which components are exposed to the wave
- Solder bath specifications, including temperature and impurities

12.4 Reflow soldering

Key characteristics in reflow soldering are:

- Lead-free versus SnPb soldering; note that a lead-free reflow process usually leads to higher minimum peak temperatures (see [Figure 24](#)) than a SnPb process, thus reducing the process window
- Solder paste printing issues including smearing, release, and adjusting the process window for a mix of large and small components on one board
- Reflow temperature profile; this profile includes preheat, reflow (in which the board is heated to the peak temperature) and cooling down. It is imperative that the peak temperature is high enough for the solder to make reliable solder joints (a solder paste characteristic). In addition, the peak temperature must be low enough that the packages and/or boards are not damaged. The peak temperature of the package depends on package thickness and volume and is classified in accordance with [Table 7](#) and [8](#)

Table 7. SnPb eutectic process (from J-STD-020C)

Package thickness (mm)	Package reflow temperature (°C)	
	Volume (mm ³)	
	< 350	≥ 350
< 2.5	235	220
≥ 2.5	220	220

Table 8. Lead-free process (from J-STD-020C)

Package thickness (mm)	Package reflow temperature (°C)		
	Volume (mm ³)		
	< 350	350 to 2000	> 2000
< 1.6	260	260	260
1.6 to 2.5	260	250	245
> 2.5	250	245	245

Moisture sensitivity precautions, as indicated on the packing, must be respected at all times.

Studies have shown that small packages reach higher temperatures during reflow soldering, see [Figure 24](#).

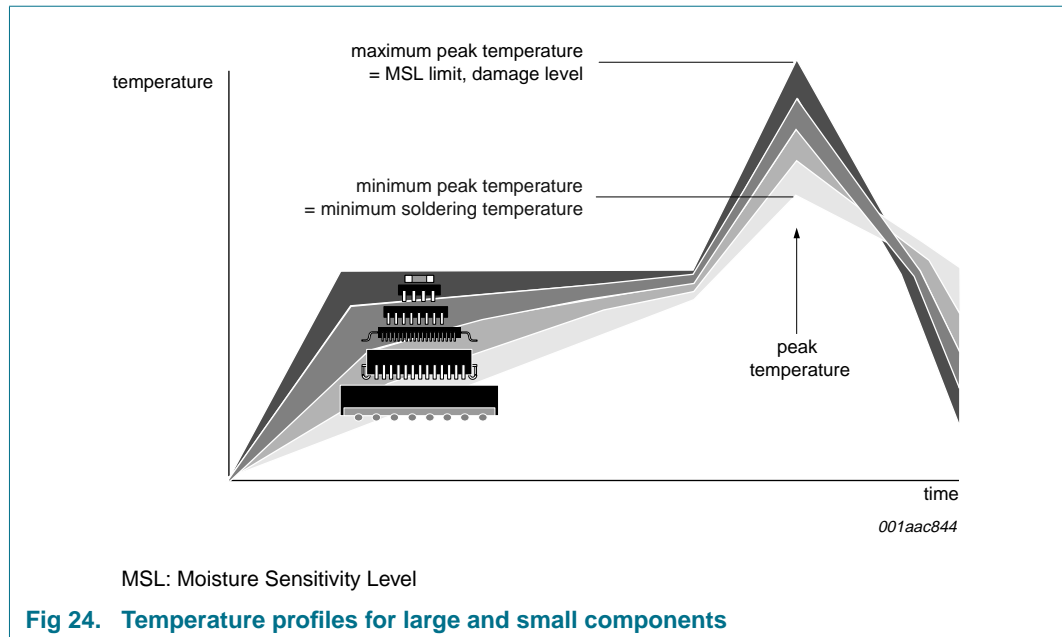

For further information on temperature profiles, refer to Application Note *AN10365* "Surface mount reflow soldering description".

13. Soldering of through-hole mount packages

13.1 Introduction to soldering through-hole mount packages

This text gives a very brief insight into wave, dip and manual soldering.

Wave soldering is the preferred method for mounting of through-hole mount IC packages on a printed-circuit board.

13.2 Soldering by dipping or by solder wave

Driven by legislation and environmental forces the worldwide use of lead-free solder pastes is increasing. Typical dwell time of the leads in the wave ranges from 3 seconds to 4 seconds at 250 °C or 265 °C, depending on solder material applied, SnPb or Pb-free respectively.

The total contact time of successive solder waves must not exceed 5 seconds.

The device may be mounted up to the seating plane, but the temperature of the plastic body must not exceed the specified maximum storage temperature ($T_{stg(max)}$). If the printed-circuit board has been pre-heated, forced cooling may be necessary immediately after soldering to keep the temperature within the permissible limit.

13.3 Manual soldering

Apply the soldering iron (24 V or less) to the lead(s) of the package, either below the seating plane or not more than 2 mm above it. If the temperature of the soldering iron bit is less than 300 °C it may remain in contact for up to 10 seconds. If the bit temperature is between 300 °C and 400 °C, contact may be up to 5 seconds.

13.4 Package related soldering information

Table 9. Suitability of through-hole mount IC packages for dipping and wave soldering

Package	Soldering method	
	Dipping	Wave
CPGA, HCPGA	-	suitable
DBS, DIP, HDIP, RDBS, SDIP, SIL	suitable	suitable ^[1]
PMFP ^[2]	-	not suitable

[1] For SDIP packages, the longitudinal axis must be parallel to the transport direction of the printed-circuit board.

[2] For PMFP packages hot bar soldering or manual soldering is suitable.

14. Abbreviations

Table 10. Abbreviations

Acronym	Description
CDM	Charged Device Model
DDC	Display Data Channel
ESD	ElectroStatic Discharge
HBM	Human Body Model
IC	Integrated Circuit
I ² C-bus	Inter IC bus
MM	Machine Model
SMBus	System Management Bus

15. Revision history

Table 11. Revision history

Document ID	Release date	Data sheet status	Change notice	Supersedes
P82B96_6	20080131	Product data sheet	-	P82B96_5
Modifications:	<ul style="list-style-type: none"> The format of this data sheet has been redesigned to comply with the new identity guidelines of NXP Semiconductors. Legal texts have been adapted to the new company name where appropriate. Table 5 "Characteristics", sub-section "Bus pull-up (load) voltages and currents", I_{Sx}, I_{Sy}; leakage current on I²C-bus: change condition "V_{Sx}, $V_{Sy} = 5\text{ V}$; V_{Rx}, $V_{Ry} = \text{LOW}$" to "V_{Sx}, $V_{Sy} = 5\text{ V}$; V_{Rx}, $V_{Ry} = \text{HIGH}$" Section 10 "Application information", 3rd paragraph on page 12: last 2 sentences re-written. Figure 15 "Falling edge of SCL at master is delayed by the buffers and bus fall times": appended "+ 10 V_{CCS}" to end of equation for effective delay of SCL at slave. 			
P82B96_5	20060127	Product data sheet	-	P82B96_4
P82B96_4 (9397 750 12932)	20040329	Product data	-	P82B96_3
P82B96_3 (9397 750 11351)	20030402	Product data	853-2241 29602 of 2003 Feb 28	P82B96_2
P82B96_2 (9397 750 11093)	20030220	Product data	853-2241 29410 of 2003 Jan 22	P82B96_1
P82B96_1 (9397 750 08122)	20010306	Product data	853-2241 25758 of 2001 Mar 06	-

16. Legal information

16.1 Data sheet status

Document status ^{[1][2]}	Product status ^[3]	Definition
Objective [short] data sheet	Development	This document contains data from the objective specification for product development.
Preliminary [short] data sheet	Qualification	This document contains data from the preliminary specification.
Product [short] data sheet	Production	This document contains the product specification.

[1] Please consult the most recently issued document before initiating or completing a design.

[2] The term 'short data sheet' is explained in section "Definitions".

[3] The product status of device(s) described in this document may have changed since this document was published and may differ in case of multiple devices. The latest product status information is available on the Internet at URL <http://www.nxp.com>.

16.2 Definitions

Draft — The document is a draft version only. The content is still under internal review and subject to formal approval, which may result in modifications or additions. NXP Semiconductors does not give any representations or warranties as to the accuracy or completeness of information included herein and shall have no liability for the consequences of use of such information.

Short data sheet — A short data sheet is an extract from a full data sheet with the same product type number(s) and title. A short data sheet is intended for quick reference only and should not be relied upon to contain detailed and full information. For detailed and full information see the relevant full data sheet, which is available on request via the local NXP Semiconductors sales office. In case of any inconsistency or conflict with the short data sheet, the full data sheet shall prevail.

16.3 Disclaimers

General — Information in this document is believed to be accurate and reliable. However, NXP Semiconductors does not give any representations or warranties, expressed or implied, as to the accuracy or completeness of such information and shall have no liability for the consequences of use of such information.

Right to make changes — NXP Semiconductors reserves the right to make changes to information published in this document, including without limitation specifications and product descriptions, at any time and without notice. This document supersedes and replaces all information supplied prior to the publication hereof.

Suitability for use — NXP Semiconductors products are not designed, authorized or warranted to be suitable for use in medical, military, aircraft, space or life support equipment, nor in applications where failure or malfunction of an NXP Semiconductors product can reasonably be expected

to result in personal injury, death or severe property or environmental damage. NXP Semiconductors accepts no liability for inclusion and/or use of NXP Semiconductors products in such equipment or applications and therefore such inclusion and/or use is at the customer's own risk.

Applications — Applications that are described herein for any of these products are for illustrative purposes only. NXP Semiconductors makes no representation or warranty that such applications will be suitable for the specified use without further testing or modification.

Limiting values — Stress above one or more limiting values (as defined in the Absolute Maximum Ratings System of IEC 60134) may cause permanent damage to the device. Limiting values are stress ratings only and operation of the device at these or any other conditions above those given in the Characteristics sections of this document is not implied. Exposure to limiting values for extended periods may affect device reliability.

Terms and conditions of sale — NXP Semiconductors products are sold subject to the general terms and conditions of commercial sale, as published at <http://www.nxp.com/profile/terms>, including those pertaining to warranty, intellectual property rights infringement and limitation of liability, unless explicitly otherwise agreed to in writing by NXP Semiconductors. In case of any inconsistency or conflict between information in this document and such terms and conditions, the latter will prevail.

No offer to sell or license — Nothing in this document may be interpreted or construed as an offer to sell products that is open for acceptance or the grant, conveyance or implication of any license under any copyrights, patents or other industrial or intellectual property rights.

16.4 Trademarks

Notice: All referenced brands, product names, service names and trademarks are the property of their respective owners.

I²C-bus — logo is a trademark of NXP B.V.

17. Contact information

For more information, please visit: <http://www.nxp.com>

For sales office addresses, please send an email to: salesaddresses@nxp.com

18. Contents

1 General description 1

2 Features 1

3 Applications 2

4 Ordering information 2

4.1 Ordering options 2

5 Block diagram 3

6 Pinning information 3

6.1 Pinning 3

6.2 Pin description 3

7 Functional description 4

8 Limiting values 5

9 Characteristics 6

10 Application information 10

10.1 Calculating system delays and bus clock frequency for a Fast mode system 15

11 Package outline 19

12 Soldering of SMD packages 22

12.1 Introduction to soldering 22

12.2 Wave and reflow soldering 22

12.3 Wave soldering 22

12.4 Reflow soldering 23

13 Soldering of through-hole mount packages . 24

13.1 Introduction to soldering through-hole mount packages 24

13.2 Soldering by dipping or by solder wave 24

13.3 Manual soldering 24

13.4 Package related soldering information 25

14 Abbreviations 25

15 Revision history 26

16 Legal information 27

16.1 Data sheet status 27

16.2 Definitions 27

16.3 Disclaimers 27

16.4 Trademarks 27

17 Contact information 27

18 Contents 28

Please be aware that important notices concerning this document and the product(s) described herein, have been included in section 'Legal information'.



© NXP B.V. 2008.

All rights reserved.

For more information, please visit: <http://www.nxp.com>

For sales office addresses, please send an email to: salesaddresses@nxp.com

Date of release: 31 January 2008

Document identifier: P82B96_6