

P82B715 I²C Bus Extender

1 Features

- Operating Power-Supply Voltage Range of 3 V to 12 V
- Supports Bidirectional Data Transfer of I²C Bus Signals
- Allows Bus Capacitance of 400 pF on Main I²C Bus (Sx/Sy Side) and 3000 pF on Transmission Side (Lx/Ly Side)
- Dual Bidirectional Unity-Voltage-Gain Buffer With No External Directional Control Required
- Drives 10× Lower-Impedance Bus Wiring for Improved Noise Immunity
- Multi-Drop Distribution of I²C Signals Using Low-Cost Twisted-Pair Cables
- I²C Bus Operation Over 50 Meters of Twisted-Pair Wire
- Latch-up Performance Exceeds 100 mA Per JESD 78, Class II
- ESD Protection Exceeds JESD 22
 - 2500-V Human-Body Model (A114-A)
 - 400-V Machine Model (A115-A)
 - 1000-V Charged-Device Model (C101)

2 Applications

- HDMI DDC
- Long I²C Communications
- Industrial Communications

3 Description

The P82B715 is a device for buffering highly-capacitive I²C bus systems, and it supports bidirectional data transfer through the I²C bus. The P82B715 buffers both the serial data (SDA) and serial clock (SCL) signals on the I²C bus and allows for extension of the I²C bus, while retaining all the operating modes and features of the I²C system.

Device Information⁽¹⁾

PART NUMBER	PACKAGE	BODY SIZE (NOM)
P82B715	SOIC (8)	4.90 mm × 3.91 mm
	PDIP (8)	9.81 mm × 6.35 mm

(1) For all available packages, see the orderable addendum at the end of the data sheet.

Block Diagram

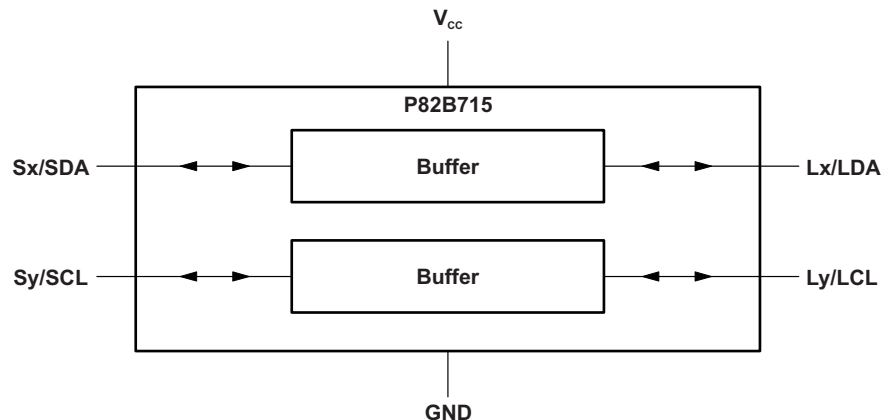

Table of Contents

1 Features 1 2 Applications 1 3 Description 1 4 Revision History 2 5 Pin Configuration and Functions 3 6 Specifications 4 6.1 Absolute Maximum Ratings 4 6.2 ESD Ratings..... 4 6.3 Recommended Operating Conditions 4 6.4 Thermal Information 4 6.5 Electrical Characteristics..... 5 6.6 Switching Characteristics 5 6.7 Typical Characteristics 6 7 Parameter Measurement Information 6 8 Detailed Description 7 8.1 Overview 7	8.2 Functional Block Diagram 7 8.3 Feature Description..... 7 8.4 Device Functional Modes..... 8 9 Application and Implementation 9 9.1 Application Information..... 9 9.2 Typical Application 9 10 Power Supply Recommendations 13 11 Layout 13 11.1 Layout Guidelines 13 11.2 Layout Example 13 12 Device and Documentation Support 14 12.1 Community Resource..... 14 12.2 Trademarks 14 12.3 Electrostatic Discharge Caution..... 14 12.4 Glossary 14 13 Mechanical, Packaging, and Orderable Information 14
---	--

4 Revision History

NOTE: Page numbers for previous revisions may differ from page numbers in the current version.

Changes from Revision A (February 2008) to Revision B	Page
<ul style="list-style-type: none"> • Added <i>ESD Ratings</i> table, <i>Feature Description</i> section, <i>Device Functional Modes</i>, <i>Application and Implementation</i> section, <i>Power Supply Recommendations</i> section, <i>Layout</i> section, <i>Device and Documentation Support</i> section, and <i>Mechanical, Packaging, and Orderable Information</i> section 	1

5 Pin Configuration and Functions



Pin Functions

PIN		I/O	DESCRIPTION
NO.	NAME		
1	NC	—	No connection
2	Lx	I/O	Buffered serial data bus or LDA
3	Sx	I/O	Serial data bus or SDA. Connect to V_{CC} of I ² C master through a pullup resistor.
4	GND	—	Ground
5	NC	—	No connection
6	Sy	I/O	Serial clock bus or SCL. Connect to V_{CC} of I ² C master through a pullup resistor.
7	Ly	I/O	Buffered serial clock bus or LCL
8	V_{CC}	I	Supply voltage

6 Specifications

6.1 Absolute Maximum Ratings

over operating free-air temperature range (unless otherwise noted)⁽¹⁾

			MIN	MAX	UNIT
V _{CC}	Supply voltage		-0.3	12	V
V _b	I ² C bus voltage	Sx or Sy	0	V _{CC}	V
	Buffered bus voltage	Lx or Ly	0	V _{CC}	
I _O	Continuous output current	Sx or Sy		60	mA
		Lx or Ly		60	
I _{CC}	Continuous current through V _{CC} or GND			60	mA
T _{stg}	Storage temperature		-55	125	°C

- (1) Stresses beyond those listed under *Absolute Maximum Ratings* may cause permanent damage to the device. These are stress ratings only, which do not imply functional operation of the device at these or any other conditions beyond those indicated under *Recommended Operating Conditions*. Exposure to absolute-maximum-rated conditions for extended periods may affect device reliability.

6.2 ESD Ratings

			VALUE	UNIT
V _(ESD)	Electrostatic discharge	Human-body model (HBM), per ANSI/ESDA/JEDEC JS-001 ⁽¹⁾	±2500	V
		Charged-device model (CDM), per JEDEC specification JESD22-C101 ⁽²⁾	±1000	
		Machine model (MM)	±400	

- (1) JEDEC document JEP155 states that 500-V HBM allows safe manufacturing with a standard ESD control process.

- (2) JEDEC document JEP157 states that 250-V CDM allows safe manufacturing with a standard ESD control process.

6.3 Recommended Operating Conditions

			MIN	MAX	UNIT
V _{CC}	Supply voltage ⁽¹⁾		4.5	12	V
T _A	Operating free-air temperature		-40	85	°C

- (1) Operation with reduced performance is possible down to 3 V. Typical static sinking performance is not degraded at 3 V, but the dynamic sink currents while the output is being driven through V_{CC}/2 are reduced and can increase fall times. Timing-critical designs should accommodate the specified minimums.

6.4 Thermal Information

THERMAL METRIC ⁽¹⁾		P82B715		UNIT
		D (SOIC)	P (PDIP)	
		8 PINS	8 PINS	
R _{θJA}	Junction-to-ambient thermal resistance	105.3	48.9	°C/W
R _{θJC(top)}	Junction-to-case (top) thermal resistance	51.1	38.1	°C/W
R _{θJB}	Junction-to-board thermal resistance	46.2	26.1	°C/W
ψ _{JT}	Junction-to-top characterization parameter	8.5	15.4	°C/W
ψ _{JB}	Junction-to-board characterization parameter	45.6	26	°C/W
R _{θJC(bot)}	Junction-to-case (bottom) thermal resistance	N/A	N/A	°C/W

- (1) For more information about traditional and new thermal metrics, see the *Semiconductor and IC Package Thermal Metrics* application report, [SPRA953](#).

6.5 Electrical Characteristics

 $V_{CC} = 5\text{ V}$, $T_A = 25^\circ\text{C}$, voltages are specified with respect to GND (unless otherwise specified)

PARAMETER		TEST CONDITIONS		MIN	TYP	MAX	UNIT
I_{CC}	Quiescent supply current	$S_x = S_y = V_{CC}$			14		mA
		$V_{CC} = 12\text{ V}$			15		
		Both I ² C inputs low, Both buffered outputs sinking 30 mA			22		
I_{IOS}	Output sink current on I ² C bus	S_x, S_y	$V_{CC} > 3\text{ V}$, $V_{S_x}, V_{S_y}(\text{low}) = 0.4\text{ V}$, $V_{L_x}, V_{L_y}(\text{low})$ on buffered bus = 0.3 V, $I_{L_x}, I_{L_y} = -3\text{ mA}$ ⁽¹⁾	2.6			mA
I_{IOL}	Output sink current on buffered bus	L_x, L_y	$V_{L_x}, V_{L_y}(\text{low}) = 0.4\text{ V}$, $V_{S_x}, V_{S_y}(\text{low})$ on I ² C bus = 0.3 V	30			mA
			$3\text{ V} < V_{CC} < 4.5\text{ V}$, $V_{L_x}, V_{L_y}(\text{low}) = 0.4\text{ V}$ to 1.5 V, I_{S_x}, I_{S_y} sinking on I ² C bus < -4 mA	24			
			$3\text{ V} < V_{CC} < 4.5\text{ V}$, $V_{L_x}, V_{L_y}(\text{low}) = 1.5\text{ V}$ to V_{CC} , I_{S_x}, I_{S_y} sinking on I ² C bus = -7 mA	24			
I_i	Input current from I ² C bus	S_x, S_y	I_{L_x}, I_{L_y} sink on buffered bus = 30 mA			-3.2	mA
	Input current from buffered bus ⁽¹⁾		$V_{CC} > 3\text{ V}$, I_{S_x}, I_{S_y} sink on I ² C bus = 3 mA ⁽¹⁾			-3	
	Leakage current on buffered bus	L_x, L_y	$V_{CC} = 3\text{ V}$ to 12 V, $V_{L_x}, V_{L_y} = V_{CC}$, $V_{S_x}, V_{S_y} = V_{CC}$			200	
Z_{in}/Z_{out}	Input/output impedance	$V_{S_x} < V_{L_x}$, Buffer is active		8	10	13	

(1) Buffer is passive in this test. The S_x/S_y sink current flows through an internal resistor to the driver connected at the L_x/L_y I/O.

6.6 Switching Characteristics

 $V_{CC} = 5\text{ V}$, $T_A = 25^\circ\text{C}$, no capacitive loads, voltages are specified with respect to GND (unless otherwise specified)

PARAMETER		TEST CONDITIONS	FROM (INPUT)	TO (OUTPUT)	MIN	TYP	MAX	UNIT
BUFFER DELAY TIMES								
$t_{\text{rise/fall}}$	Delay time to V_{L_x} voltage crossing $V_{CC}/2$ for input drive current step I_{S_x} at S_x ⁽¹⁾ (see Figure 2)	R_{L_x} pullup = 270 Ω	I_{S_x} I_{S_y}	V_{L_x} V_{L_y}		250		ns
	Buffer delay time, switching edges between V_{L_x} input and V_{S_x} output ⁽²⁾	R_{L_x} pullup = 4700 Ω	V_{L_x} V_{L_y}	V_{S_x} V_{S_y}		0		ns

- (1) A conventional input-output delay is not observed in the S_x/L_x voltage waveforms, because the input and output pins are internally tied with a 30- Ω resistor so they show equal logic voltage levels to within 100 mV. When connected in an I²C system, an S_x/S_y input pin cannot rise/fall until the buffered bus load at the output pin has been driven by the internal amplifier. This test measures the bus propagation delay caused to falling or rising voltages at the L_x/L_y output (as well as the S_x/S_y input) by the amplifier's response time. The figure given is measured with a drive current as shown in Figure 2. Because this is a dynamic bus test in which a corresponding bus driving IC has an output voltage well above 0.4 V, 6 mA is used instead of the static 3 mA.
- (2) The signal path L_x to S_x and L_y to S_y is passive through the internal 30- Ω resistor. There is no amplifier involved and essentially no signal propagation delay.

6.7 Typical Characteristics

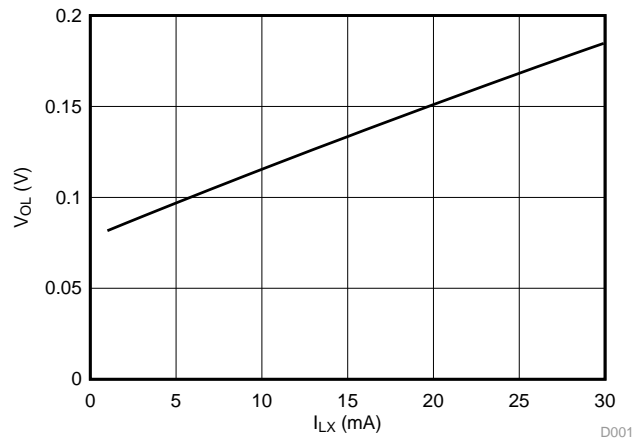

Figure 1. Typical V_{OL} of Lx/Ly (R_{PU} on Sx = 4.7 k Ω , T_A = 25 C, V_{SX} = 0 V)

7 Parameter Measurement Information

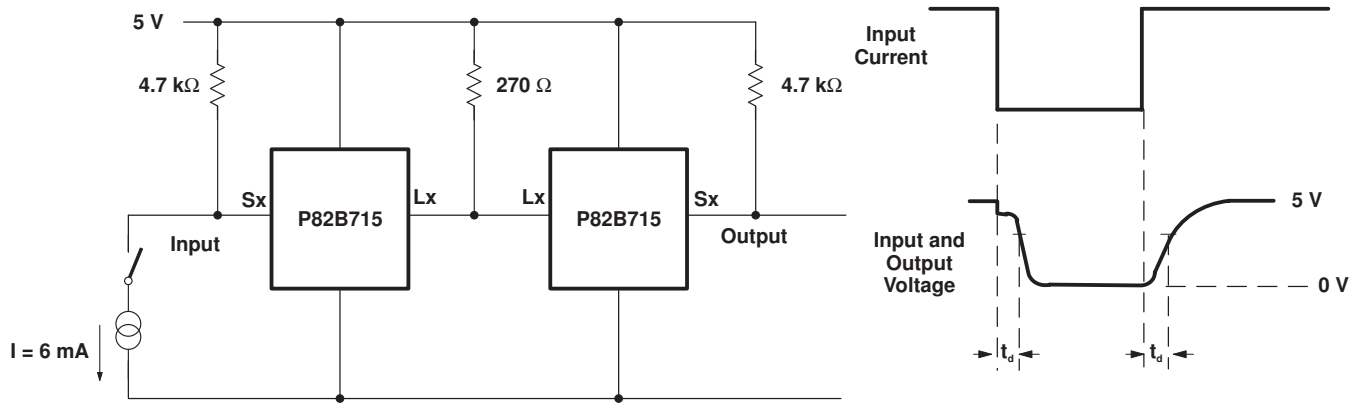

Figure 2. Test Circuit for Delay Times

8 Detailed Description

8.1 Overview

The I²C bus capacitance limit of 400 pF restricts practical communication distances to a few meters. One of the advantages of the P82B715 is that it can isolate bus capacitance such that the total loading (devices, connectors, traces and wires) of the new bus or remote I²C nodes are not apparent to other I²C buses (or nodes). This is achieved by using one P82B715 device at each end of a long cable. The pin Lx of one P82B715 device must be connected to Lx of the second P82B715 (similarly for Ly). This allows the total system capacitance load to be around 3000 pF. The P82B715 uses unidirectional analog current amplification to increase the current sink capability of I²C chips to change the 400-pF I²C bus specification limit into a 3-nF bus wiring capacitance limit. That means longer cables or lower-cost general-purpose wiring may be used to connect two separate I²C-based systems, without worrying about the special voltage levels associated with other I²C bus buffers.

Multiple P82B715s can be connected together in a star or multipoint architecture by their Lx/Ly ports, without limit, as long as the total capacitance of the system remains less than about 3000 pF (400 pF or less when referenced to any Sx/Sy connection). In that arrangement, the master and/or slave devices are attached to the Sx/Sy port of each P82B715. In normal use, the power-supply voltages at each end of the low-impedance buffered bus line should be the same. If these differ by a significant amount, noise margin is sacrificed.

Two or more Sx or Sy I/Os can be interconnected and are also fully compatible with bus buffers that use voltage-level offsets (such as the [TCA9517](#)) because it duplicates and transmits the offset voltage.

8.2 Functional Block Diagram

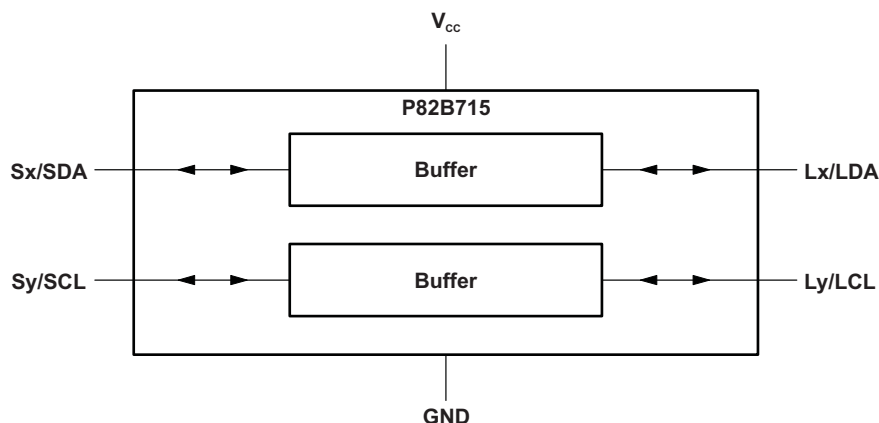

8.3 Feature Description

8.3.1 Sx and Sy

The I²C pins (Sx and Sy) are designed to interface with a normal I²C bus. The maximum I²C bus supply voltage is 12 V. The Sx and Sy pins contain identical circuitry and can be used interchangeably as SCL or SDA.

8.3.2 Lx and Ly

The Lx and Ly pins are designed to interface with the high capacitance bus. This port of the device features circuitry to assist in sinking large amounts of currents required to operate a large capacitance bus at high speeds. More on this circuitry can be found in [Lx/Ly Buffered Bus Circuitry](#).

8.3.3 Lx/Ly Buffered Bus Circuitry

On the special low-impedance or buffered-line side, the corresponding output becomes the LDA data line or LCL clock line. The P82B715 provides current amplification from its I²C bus to its low impedance or buffered bus. Whenever current is flowing out of Sx into an I²C chip driving the I²C bus low, its amplifier sinks ten times that current into Lx, to drive the buffered bus low (see [Figure 3](#)). To minimize interference and ensure stability, the current rise and fall times of the Lx drive amplifier are internally controlled. The P82B715 does not amplify signal

Feature Description (continued)

currents flowing into S_x on the I²C bus driven by currents flowing out of L_x on the buffered side. A buffered bus logic low signal at L_x passes through the internal 30- Ω resistor to drive the I²C bus low. This signal current amplification, dependent on its direction, preserves the multi-master bidirectional open-collector/open-drain characteristic of any connected I²C bus lines and the new low-impedance bus. Bus logic-signal voltage levels are clamped at $(V_{CC} + 0.7\text{ V})$ but, otherwise, are independent of the supply voltage, V_{CC} .

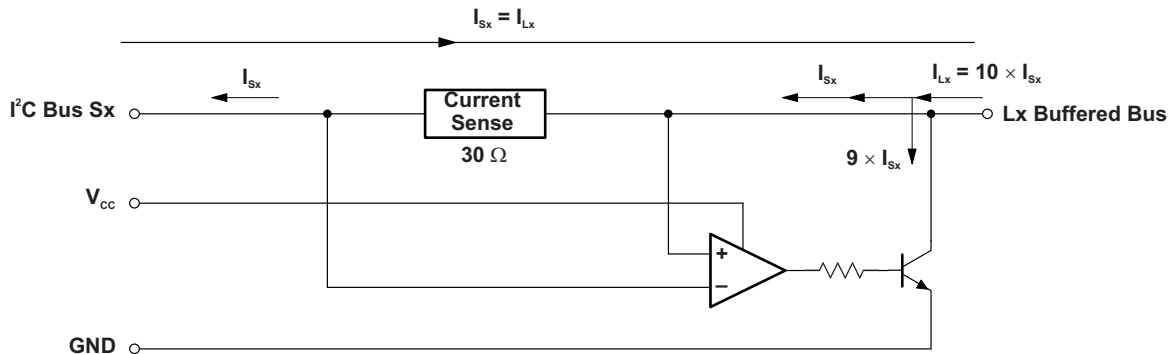

Figure 3. Equivalent Circuit (One-Half of P82B715)

8.4 Device Functional Modes

The P82B715 has two modes when powered, which depend on the state of the I²C bus.

8.4.1 Idle Bus

When the I²C bus is idle and high, little or no current flows through the device. In this case, the L_x/L_y buffer is not turned on.

8.4.2 Active-Low Bus

When a device connected to the S_x / S_y side of the device is transmitting a 0, a large amount of current will flow through the P82B715, which activates the internal pulldown to assist with the large capacitance.

9 Application and Implementation

NOTE

Information in the following applications sections is not part of the TI component specification, and TI does not warrant its accuracy or completeness. TI's customers are responsible for determining suitability of components for their purposes. Customers should validate and test their design implementation to confirm system functionality.

9.1 Application Information

The P82B715 can operate with a supply voltage from 3 V to 12 V, but the logic-signal levels at Sx/Lx are independent of the supply voltage. They remain at the levels presented to the chip by the attached devices. The maximum static I²C bus sink current, 3 mA, flowing in either direction in the internal current sense resistor, causes a difference less than 100 mV in the bus logic low levels at Sx and Lx. This makes P82B715 fully compatible with all logic signal drivers, including TTL. The P82B715 cannot modify the bus logic signal voltage levels, but it contains internal diodes connected between Lx/Sx and V_{CC} that conduct and limit the logic signal swing if the applied logic levels would have exceeded the supply voltage by more than 0.7 V.

In normal applications, external pullup resistors pull the connected buses up to the desired voltage high level. Usually this is the supply voltage, V_{CC}, but for very low logic voltages, it is necessary to use a V_{CC} of at least 3.3 V and preferably higher. Note that full performance over temperature is ensured only from 4.5 V. Specification deratings apply when its supply voltage is reduced below 4.5 V. The absolute minimum V_{CC} is 3 V.

9.2 Typical Application

By using two (or more) P82B715 devices, a subsystem can be built that retains the interface characteristics of a normal I²C device so that the subsystem may be included in, or added to, any I²C or related system.

The subsystem features a low-impedance or buffered bus capable of driving large wiring capacitance (see Figure 4).

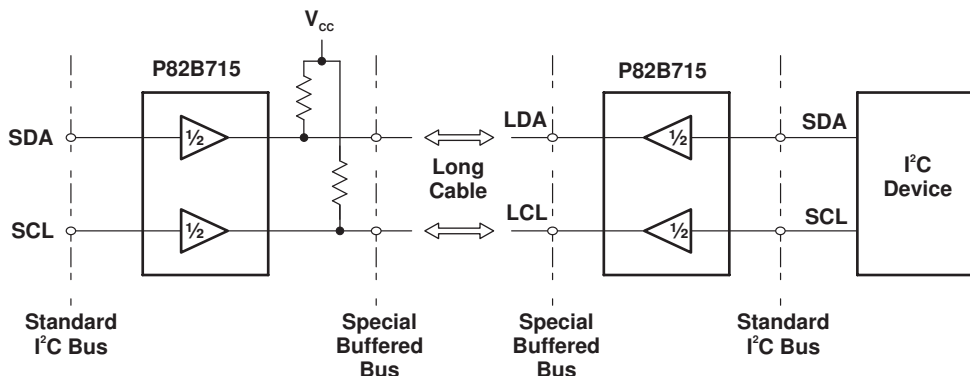

Figure 4. Minimum Subsystem Diagram

9.2.1 Design Requirements

Table 1 lists the design parameters for this example.

Table 1. Design Parameters

PARAMETER	DESCRIPTION	VALUE
V _{CC}	Supply Voltage	3.3 V
C _{Lx}	Capacitance on the Lx / Ly bus	3000 pF
R _{PU_Sx}	Pullup resistor for the Sx / Sy bus	4700 Ω
R _{PU_Lx}	Pullup resistor for the Lx / Ly bus	330 Ω

9.2.2 Detailed Design Procedure

9.2.2.1 I²C Systems

As in standard I²C systems, pullup resistors are required to provide the logic high levels on the buffered bus, as the standard open-collector configuration is retained. The size and number of pullup resistors depends on the system.

If P82B715 devices are to be permanently connected into a system, the circuit may be configured with only one pullup resistor on the buffered bus and none on the I²C buses, but the system design is simplified, and performance is improved by fitting separate pullups on each section of the bus. When a subsystem using P82B715 may be optionally connected to an existing I²C system that already has a pullup, the effects of the subsystem pullups acting in parallel with the existing I²C bus pullup must be considered.

9.2.2.2 Pullup Resistance Calculation

When calculating the pullup resistance values, the gain of the buffer introduces scaling factors that must be applied to the system components. In practical systems, the pullup resistance value is calculated to meet the rise time limit for I²C systems. As an approximation, this limit is satisfied in a 100-kHz system if the time constant of the total system (product of the net resistance and net capacitance) is set to 1 μs or less.

In systems using the P82B715, it is convenient to set the total system time constant by considering each bus node separately (that is, the I²C nodes and the buffered bus node) and selecting a separate pullup resistor for each node to provide time constants of less than 1 μs. If each node complies then the system requirement is also met.

This arrangement, using multiple pullups as shown in Figure 5, provides the best system performance and allows stand-alone operation of individual I²C buses if parts of the extended system are disconnected or reconnected. For each bus section, the pullup resistor is calculated as:

$$R = 1 \mu\text{s} / (C_{\text{device}} + C_{\text{wiring}})$$

where

- C_{device} = Sum of any connected device capacitances
 - C_{wiring} = Total wiring and stray capacitance on the bus section
- (1)

The 1 μs is an approximation with a safety factor to the theoretical time constant necessary to meet the specified 1-μs bus rise-time specification in a system with variable logic thresholds, where the CMOS limits of 30% and 70% of V_{CC} apply. The calculated value is 1.18 μs.

If these capacitances cannot be measured or calculated, an approximation can be made by assuming that each device presents 10 pF of load capacitance and 10 pF of trace capacitance, and that cables range from 50 pF to 100 pF per meter.

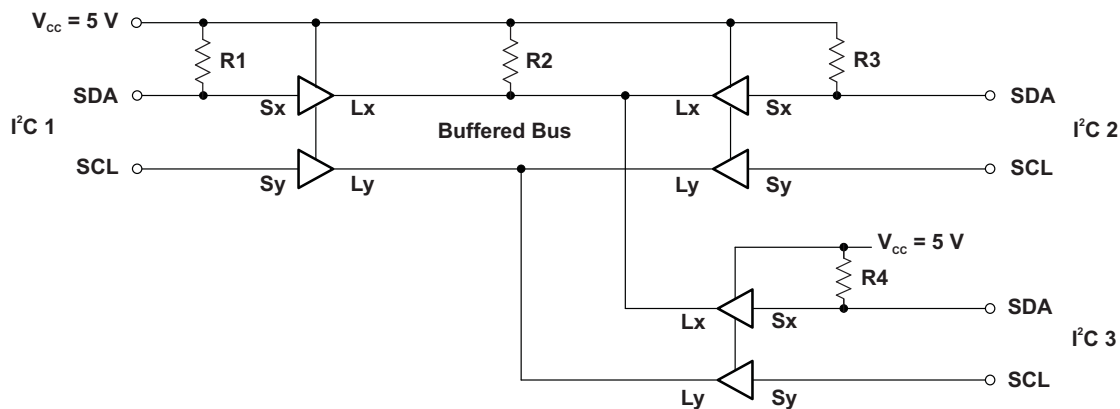

Figure 5. Single Pullup Buffered Bus

If only a single pullup is used, it must be placed on the buffered bus (as R2 in Figure 5) and the associated total system capacitance calculated by combining the individual bus capacitances into an equivalent capacitive loading on the buffered bus.

This equivalent capacitance is the sum of the capacitance on the buffered bus plus ten times the sum of the capacitances on all the connected I²C nodes. The calculated value should not exceed 4 nF. The single buffered bus pullup resistor is then calculated to achieve the 1- μ s rise time, and it provides the pullup for the buffered bus and for all other connected I²C bus nodes included in the calculation.

9.2.2.3 Calculating Bus Drive Currents

Figure 5 shows three P82B715 devices connected to a common buffered bus. The associated bus capacitances are omitted for clarity, but assume the resistors have been selected to give R-C products of less than 1 μ s so the bus rise-time requirement is satisfied. An I²C device connected at I²C 1 and holding the SDA bus low must sink the current flowing in its local pullup R1, plus, with assistance from the P82B715, the currents in R2, R3, and R4. Because the resistors R3 and R4 act to pull the bus nodes I²C 2 and I²C 3 and their corresponding Sx pins to a voltage higher than the voltage at the Lx pins, their buffer amplifiers are inactive. The SDA at Sx of I²C 2 and I²C 3 is pulled low by the low at Lx through the internal 30- Ω resistor that links Lx to Sx. So the effective current that must be sunk by the P82B715 buffer on I²C 1 at its Lx pin is the sum of the currents in R2, R3, and R4. The Sx current that must be sunk by an I²C device at I²C 1 due to the buffer gain action is 1/10 of the Lx current. So the effective pullup determining the current to be sunk by an I²C device at I²C 1 is R1 in parallel with resistors ten times the values of R2, R3, and R4. If R1 = R3 = R4 = 10 k Ω , and R2 = 1 k Ω , the effective pullup load at I²C 1 is 10 k Ω ||10 k Ω ||100 k Ω ||100 k Ω = 4.55 k Ω .

The same calculation applies for I²C 2 or I²C 3.

To calculate the current sunk by the Lx pin of the buffer at I²C 1, note that the current in R1 is sunk directly by the device at I²C 1. The buffer, therefore, sinks only the currents flowing in R2, R3, and R4, so the effective pullup is R2 in parallel with R3 and R4.

In this example that is 1 k Ω ||10 k Ω ||10 k Ω = 833 Ω . For a 5.5-V supply and 0.4-V low, the buffer is sinking 16.3 mA.

The P82B715 has a static sink rating of 30 mA at Lx. The requirement is that the pullup on the buffered bus, in parallel with all other pullups that it is indirectly pulling low on Sx pins of other P82B715 devices, does not cause this 30-mA limit to be exceeded.

The minimum pullup resistance in a 5-V \pm 10% system is 170 Ω .

The general requirement is:

$$(V_{CC(max)} - 0.4)/R_p < 30 \text{ mA}$$

where

- R_p = Parallel combination of all pullup resistors driven by the Lx pin of the P82B715 (2)

Figure 6 shows calculations for an expanded I²C bus with 3 nF of cable capacitance.

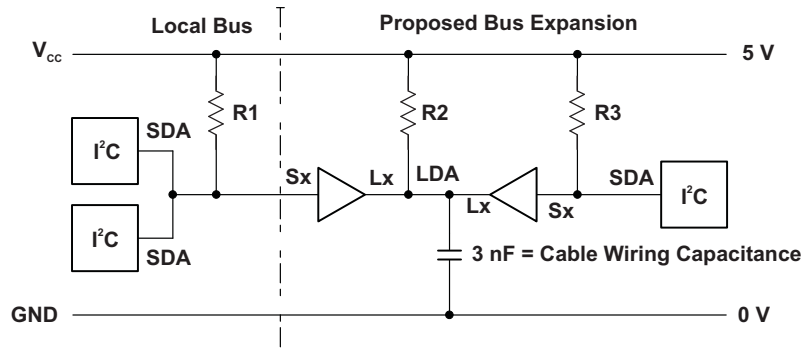

**Effective Capacitance
Local Bus I²C Devices**

2 × I ² C Devices	20 pF
Strays	20 pF
P82B715	10 pF
Total	50 pF

Local I²C Pullup

$$R1 = \frac{1 \mu\text{s}}{50 \text{ pF}} = 20 \text{ k}\Omega$$

**Effective Capacitance
Buffered Line**

Wiring Capacitance	3000 pF
Total	3000 pF

Buffered Bus Pullup

$$R2 = \frac{1 \mu\text{s}}{3000 \text{ pF}} = 330 \Omega$$

**Effective Capacitance
Remote I²C Devices**

1 × I ² C Devices	10 pF
Strays	10 pF
P82B715	10 pF
Total	30 pF

Remote I²C Pullup

$$R3 = \frac{1 \mu\text{s}}{30 \text{ pF}} = 33 \text{ k}\Omega$$

Figure 6. Typical Loading Calculations

9.2.3 Application Curve

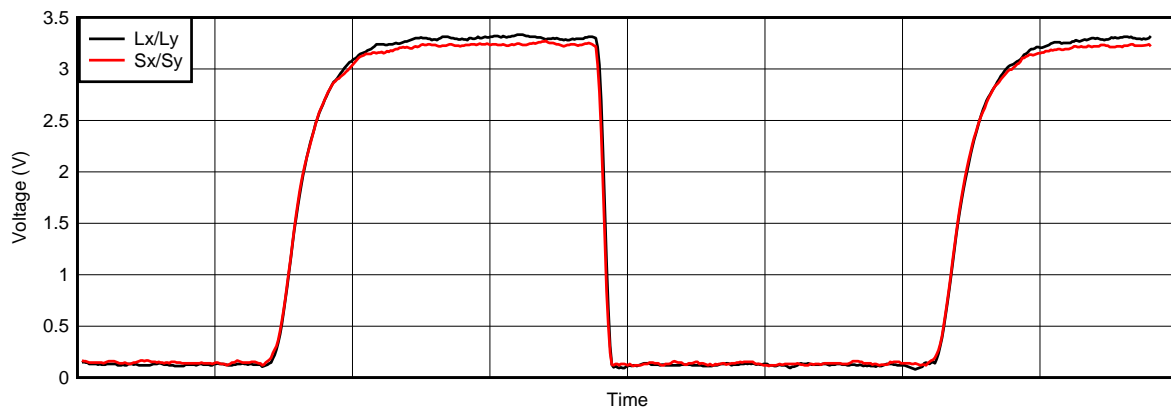

D002

Figure 7. Voltage On Bus (3000 pF on Lx/Ly With R_{PU} = 330 Ω)

10 Power Supply Recommendations

The P82B715 power supply requirements can be seen in the [Recommended Operating Conditions](#). Note that the P82B715 can operate down to 3 V, but at reduced performance.

11 Layout

11.1 Layout Guidelines

General layout best practices are recommended. It is common to have a dedicated ground plane on an inner layer of the board, and pins that are connected to ground must have a low-impedance path to the ground plane in the form of wide polygon pours, and multiple vias.

Bypass and decoupling capacitors are commonly used to control the voltage on the VCC pin, using a larger capacitor to provide additional power in the event of a short power supply glitch (typically 1 μ F), and a smaller capacitor (typically 0.1 μ F) to filter out high-frequency ripple.

11.2 Layout Example

⊙ = VIA to ground plane

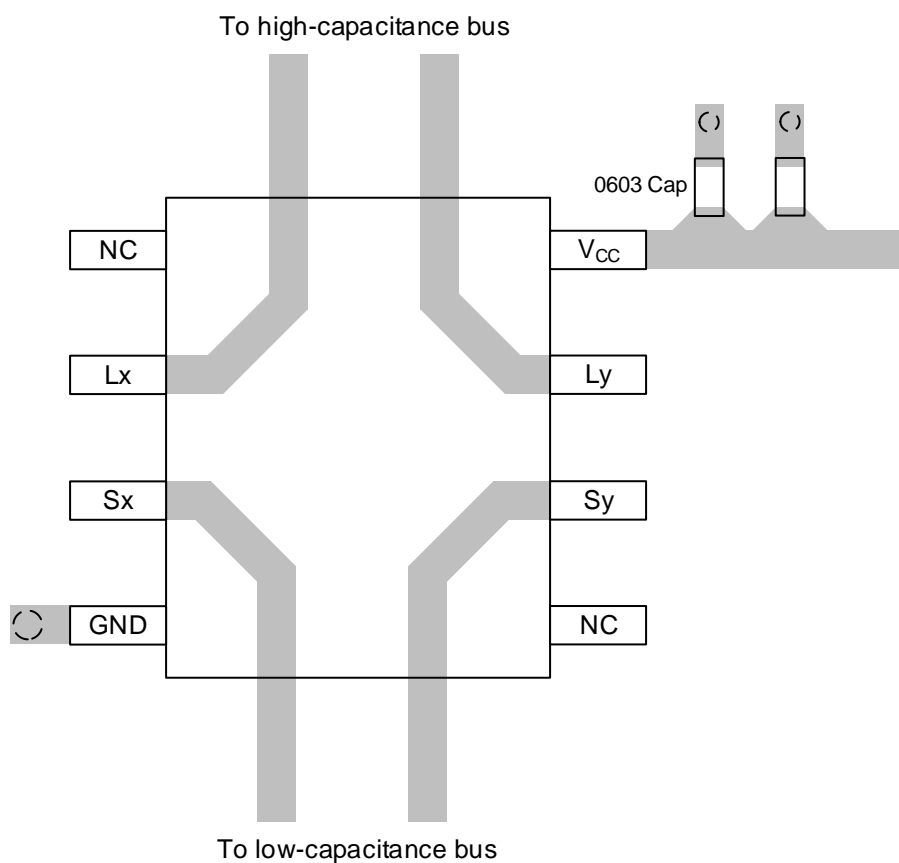

Figure 8. D Package Example Layout

12 Device and Documentation Support

12.1 Community Resource

The following links connect to TI community resources. Linked contents are provided "AS IS" by the respective contributors. They do not constitute TI specifications and do not necessarily reflect TI's views; see TI's [Terms of Use](#).

TI E2E™ Online Community *TI's Engineer-to-Engineer (E2E) Community*. Created to foster collaboration among engineers. At e2e.ti.com, you can ask questions, share knowledge, explore ideas and help solve problems with fellow engineers.

Design Support *TI's Design Support* Quickly find helpful E2E forums along with design support tools and contact information for technical support.

12.2 Trademarks

E2E is a trademark of Texas Instruments.
All other trademarks are the property of their respective owners.

12.3 Electrostatic Discharge Caution



These devices have limited built-in ESD protection. The leads should be shorted together or the device placed in conductive foam during storage or handling to prevent electrostatic damage to the MOS gates.

12.4 Glossary

[SLYZ022](#) — *TI Glossary*.

This glossary lists and explains terms, acronyms, and definitions.

13 Mechanical, Packaging, and Orderable Information

The following pages include mechanical, packaging, and orderable information. This information is the most current data available for the designated devices. This data is subject to change without notice and revision of this document. For browser-based versions of this data sheet, refer to the left-hand navigation.

PACKAGING INFORMATION

Orderable Device	Status (1)	Package Type	Package Drawing	Pins	Package Qty	Eco Plan (2)	Lead/Ball Finish (6)	MSL Peak Temp (3)	Op Temp (°C)	Device Marking (4/5)	Samples
P82B715D	ACTIVE	SOIC	D	8	75	Green (RoHS & no Sb/Br)	CU NIPDAU	Level-1-260C-UNLIM	-40 to 85	PG715	Samples
P82B715DG4	ACTIVE	SOIC	D	8	75	Green (RoHS & no Sb/Br)	CU NIPDAU	Level-1-260C-UNLIM	-40 to 85	PG715	Samples
P82B715DR	ACTIVE	SOIC	D	8	2500	Green (RoHS & no Sb/Br)	CU NIPDAU	Level-1-260C-UNLIM	-40 to 85	PG715	Samples
P82B715DRG4	ACTIVE	SOIC	D	8	2500	Green (RoHS & no Sb/Br)	CU NIPDAU	Level-1-260C-UNLIM	-40 to 85	PG715	Samples
P82B715P	ACTIVE	PDIP	P	8	50	Pb-Free (RoHS)	CU NIPDAU	N / A for Pkg Type	-40 to 85	P82B715P	Samples
P82B715PE4	ACTIVE	PDIP	P	8	50	Pb-Free (RoHS)	CU NIPDAU	N / A for Pkg Type	-40 to 85	P82B715P	Samples

(1) The marketing status values are defined as follows:

ACTIVE: Product device recommended for new designs.

LIFEBUY: TI has announced that the device will be discontinued, and a lifetime-buy period is in effect.

NRND: Not recommended for new designs. Device is in production to support existing customers, but TI does not recommend using this part in a new design.

PREVIEW: Device has been announced but is not in production. Samples may or may not be available.

OBSELETE: TI has discontinued the production of the device.

(2) Eco Plan - The planned eco-friendly classification: Pb-Free (RoHS), Pb-Free (RoHS Exempt), or Green (RoHS & no Sb/Br) - please check <http://www.ti.com/productcontent> for the latest availability information and additional product content details.

TBD: The Pb-Free/Green conversion plan has not been defined.

Pb-Free (RoHS): TI's terms "Lead-Free" or "Pb-Free" mean semiconductor products that are compatible with the current RoHS requirements for all 6 substances, including the requirement that lead not exceed 0.1% by weight in homogeneous materials. Where designed to be soldered at high temperatures, TI Pb-Free products are suitable for use in specified lead-free processes.

Pb-Free (RoHS Exempt): This component has a RoHS exemption for either 1) lead-based flip-chip solder bumps used between the die and package, or 2) lead-based die adhesive used between the die and leadframe. The component is otherwise considered Pb-Free (RoHS compatible) as defined above.

Green (RoHS & no Sb/Br): TI defines "Green" to mean Pb-Free (RoHS compatible), and free of Bromine (Br) and Antimony (Sb) based flame retardants (Br or Sb do not exceed 0.1% by weight in homogeneous material)

(3) MSL, Peak Temp. - The Moisture Sensitivity Level rating according to the JEDEC industry standard classifications, and peak solder temperature.

(4) There may be additional marking, which relates to the logo, the lot trace code information, or the environmental category on the device.

(5) Multiple Device Markings will be inside parentheses. Only one Device Marking contained in parentheses and separated by a "~" will appear on a device. If a line is indented then it is a continuation of the previous line and the two combined represent the entire Device Marking for that device.

⁽⁶⁾ Lead/Ball Finish - Orderable Devices may have multiple material finish options. Finish options are separated by a vertical ruled line. Lead/Ball Finish values may wrap to two lines if the finish value exceeds the maximum column width.

Important Information and Disclaimer: The information provided on this page represents TI's knowledge and belief as of the date that it is provided. TI bases its knowledge and belief on information provided by third parties, and makes no representation or warranty as to the accuracy of such information. Efforts are underway to better integrate information from third parties. TI has taken and continues to take reasonable steps to provide representative and accurate information but may not have conducted destructive testing or chemical analysis on incoming materials and chemicals. TI and TI suppliers consider certain information to be proprietary, and thus CAS numbers and other limited information may not be available for release.

In no event shall TI's liability arising out of such information exceed the total purchase price of the TI part(s) at issue in this document sold by TI to Customer on an annual basis.

TAPE AND REEL INFORMATION



QUADRANT ASSIGNMENTS FOR PIN 1 ORIENTATION IN TAPE



*All dimensions are nominal

Device	Package Type	Package Drawing	Pins	SPQ	Reel Diameter (mm)	Reel Width W1 (mm)	A0 (mm)	B0 (mm)	K0 (mm)	P1 (mm)	W (mm)	Pin1 Quadrant
P82B715DR	SOIC	D	8	2500	330.0	12.4	6.4	5.2	2.1	8.0	12.0	Q1

TAPE AND REEL BOX DIMENSIONS



*All dimensions are nominal

Device	Package Type	Package Drawing	Pins	SPQ	Length (mm)	Width (mm)	Height (mm)
P82B715DR	SOIC	D	8	2500	367.0	367.0	35.0

P (R-PDIP-T8)

PLASTIC DUAL-IN-LINE PACKAGE



- NOTES:
- A. All linear dimensions are in inches (millimeters).
 - B. This drawing is subject to change without notice.
 - C. Falls within JEDEC MS-001 variation BA.

D (R-PDSO-G8)

PLASTIC SMALL OUTLINE



NOTES: A. All linear dimensions are in inches (millimeters).
 B. This drawing is subject to change without notice.
 C. Body length does not include mold flash, protrusions, or gate burrs. Mold flash, protrusions, or gate burrs shall not exceed 0.006 (0,15) each side.
 D. Body width does not include interlead flash. Interlead flash shall not exceed 0.017 (0,43) each side.
 E. Reference JEDEC MS-012 variation AA.

D (R-PDSO-G8)

PLASTIC SMALL OUTLINE



- NOTES:
- A. All linear dimensions are in millimeters.
 - B. This drawing is subject to change without notice.
 - C. Publication IPC-7351 is recommended for alternate designs.
 - D. Laser cutting apertures with trapezoidal walls and also rounding corners will offer better paste release. Customers should contact their board assembly site for stencil design recommendations. Refer to IPC-7525 for other stencil recommendations.
 - E. Customers should contact their board fabrication site for solder mask tolerances between and around signal pads.

IMPORTANT NOTICE

Texas Instruments Incorporated and its subsidiaries (TI) reserve the right to make corrections, enhancements, improvements and other changes to its semiconductor products and services per JESD46, latest issue, and to discontinue any product or service per JESD48, latest issue. Buyers should obtain the latest relevant information before placing orders and should verify that such information is current and complete. All semiconductor products (also referred to herein as "components") are sold subject to TI's terms and conditions of sale supplied at the time of order acknowledgment.

TI warrants performance of its components to the specifications applicable at the time of sale, in accordance with the warranty in TI's terms and conditions of sale of semiconductor products. Testing and other quality control techniques are used to the extent TI deems necessary to support this warranty. Except where mandated by applicable law, testing of all parameters of each component is not necessarily performed.

TI assumes no liability for applications assistance or the design of Buyers' products. Buyers are responsible for their products and applications using TI components. To minimize the risks associated with Buyers' products and applications, Buyers should provide adequate design and operating safeguards.

TI does not warrant or represent that any license, either express or implied, is granted under any patent right, copyright, mask work right, or other intellectual property right relating to any combination, machine, or process in which TI components or services are used. Information published by TI regarding third-party products or services does not constitute a license to use such products or services or a warranty or endorsement thereof. Use of such information may require a license from a third party under the patents or other intellectual property of the third party, or a license from TI under the patents or other intellectual property of TI.

Reproduction of significant portions of TI information in TI data books or data sheets is permissible only if reproduction is without alteration and is accompanied by all associated warranties, conditions, limitations, and notices. TI is not responsible or liable for such altered documentation. Information of third parties may be subject to additional restrictions.

Resale of TI components or services with statements different from or beyond the parameters stated by TI for that component or service voids all express and any implied warranties for the associated TI component or service and is an unfair and deceptive business practice. TI is not responsible or liable for any such statements.

Buyer acknowledges and agrees that it is solely responsible for compliance with all legal, regulatory and safety-related requirements concerning its products, and any use of TI components in its applications, notwithstanding any applications-related information or support that may be provided by TI. Buyer represents and agrees that it has all the necessary expertise to create and implement safeguards which anticipate dangerous consequences of failures, monitor failures and their consequences, lessen the likelihood of failures that might cause harm and take appropriate remedial actions. Buyer will fully indemnify TI and its representatives against any damages arising out of the use of any TI components in safety-critical applications.

In some cases, TI components may be promoted specifically to facilitate safety-related applications. With such components, TI's goal is to help enable customers to design and create their own end-product solutions that meet applicable functional safety standards and requirements. Nonetheless, such components are subject to these terms.

No TI components are authorized for use in FDA Class III (or similar life-critical medical equipment) unless authorized officers of the parties have executed a special agreement specifically governing such use.

Only those TI components which TI has specifically designated as military grade or "enhanced plastic" are designed and intended for use in military/aerospace applications or environments. Buyer acknowledges and agrees that any military or aerospace use of TI components which have **not** been so designated is solely at the Buyer's risk, and that Buyer is solely responsible for compliance with all legal and regulatory requirements in connection with such use.

TI has specifically designated certain components as meeting ISO/TS16949 requirements, mainly for automotive use. In any case of use of non-designated products, TI will not be responsible for any failure to meet ISO/TS16949.

Products

Audio	www.ti.com/audio
Amplifiers	amplifier.ti.com
Data Converters	dataconverter.ti.com
DLP® Products	www.dlp.com
DSP	dsp.ti.com
Clocks and Timers	www.ti.com/clocks
Interface	interface.ti.com
Logic	logic.ti.com
Power Mgmt	power.ti.com
Microcontrollers	microcontroller.ti.com
RFID	www.ti-rfid.com
OMAP Applications Processors	www.ti.com/omap
Wireless Connectivity	www.ti.com/wirelessconnectivity

Applications

Automotive and Transportation	www.ti.com/automotive
Communications and Telecom	www.ti.com/communications
Computers and Peripherals	www.ti.com/computers
Consumer Electronics	www.ti.com/consumer-apps
Energy and Lighting	www.ti.com/energy
Industrial	www.ti.com/industrial
Medical	www.ti.com/medical
Security	www.ti.com/security
Space, Avionics and Defense	www.ti.com/space-avionics-defense
Video and Imaging	www.ti.com/video

TI E2E Community

e2e.ti.com