



250MHz, Rail-to-Rail I/O, CMOS Operational Amplifier with Shutdown

FEATURES

- **UNITY-GAIN BANDWIDTH: 250MHz**
- **WIDE BANDWIDTH: 100MHz GBW**
- **HIGH SLEW RATE: 150V/ μ s**
- **LOW NOISE: 6.5nV/ $\sqrt{\text{Hz}}$**
- **RAIL-TO-RAIL I/O**
- **HIGH OUTPUT CURRENT: > 100mA**
- **EXCELLENT VIDEO PERFORMANCE:**
Diff Gain: 0.02%, Diff Phase: 0.09°
0.1dB Gain Flatness: 40MHz
- **LOW INPUT BIAS CURRENT: 3pA**
- **QUIESCENT CURRENT: 4.9mA**
- **THERMAL SHUTDOWN**
- **SUPPLY RANGE: 2.5V to 5.5V**
- **SHUTDOWN $I_Q < 6\mu\text{A}$**
- **MicroSIZE AND PowerPAD™ PACKAGES**

APPLICATIONS

- VIDEO PROCESSING
- ULTRASOUND
- OPTICAL NETWORKING, TUNABLE LASERS
- PHOTODIODE TRANSIMPEDANCE AMPS
- ACTIVE FILTERS
- HIGH-SPEED INTEGRATORS
- ANALOG-TO-DIGITAL (A/D) CONVERTER INPUT BUFFERS
- DIGITAL-TO-ANALOG (D/A) CONVERTER OUTPUT AMPLIFIERS
- BARCODE SCANNERS
- COMMUNICATIONS

DESCRIPTION

The OPA357 series of high-speed, voltage-feedback CMOS operational amplifiers are designed for video and other applications requiring wide bandwidth. They are unity-gain stable and can drive large output currents. Differential gain is 0.02% and differential phase is 0.09°. Quiescent current is only 4.9mA per channel.

The OPA357 series op amps are optimized for operation on single or dual supplies as low as 2.5V ($\pm 1.25\text{V}$) and up to 5.5V ($\pm 2.75\text{V}$). Common-mode input range extends beyond the supplies. The output swing is within 100mV of the rails, supporting wide dynamic range.

For applications requiring the full 100mA continuous output current, the single SO-8 PowerPAD version is available.

The single version (OPA357), comes in the miniature SOT23-6 and SO-8 PowerPAD packages. The dual version (OPA2357) is offered in the MSOP-10 package.

The dual version features completely independent circuitry for lowest crosstalk and freedom from interaction. All are specified over the extended -40°C to $+125^\circ\text{C}$ temperature range.

OPAx357 RELATED PRODUCTS

FEATURES	PRODUCT
Non-Shutdown Version of OPA357 Family	OPAx354
200MHz GBW, Rail-to-Rail Output, CMOS, Shutdown	OPAx355
200MHz GBW, Rail-to-Rail Output, CMOS	OPAx356
38MHz GBW, Rail-to-Rail Input/Output, CMOS	OPAx350/3
75MHz BW $G = 2$, Rail-to-Rail Output	OPAx631
150MHz BW $G = 2$, Rail-to-Rail Output	OPAx634
100MHz BW, Differential Input/Output, 3.3V Supply	THS412x

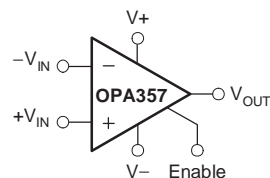

Please be aware that an important notice concerning availability, standard warranty, and use in critical applications of Texas Instruments semiconductor products and disclaimers thereto appears at the end of this data sheet.

All trademarks are the property of their respective owners.

ABSOLUTE MAXIMUM RATINGS(1)

Supply Voltage, V+ to V-	7.5V
Signal Input Terminals Voltage(2)	(V-) - (0.5V) to (V+) + (0.5V)
Current(2)	10mA
Enable Input	(V-) - (0.5V) to (V+) + (0.5V)
Output Short-Circuit(3)	Continuous
Operating Temperature	-55°C to +150°C
Storage Temperature	-65°C to +150°C
Junction Temperature	+150°C
Lead Temperature (soldering, 10s)	+300°C



ELECTROSTATIC DISCHARGE SENSITIVITY

This integrated circuit can be damaged by ESD. Texas Instruments recommends that all integrated circuits be handled with appropriate precautions. Failure to observe proper handling and installation procedures can cause damage.

ESD damage can range from subtle performance degradation to complete device failure. Precision integrated circuits may be more susceptible to damage because very small parametric changes could cause the device not to meet its published specifications.

- (1) Stresses above these ratings may cause permanent damage. Exposure to absolute maximum conditions for extended periods may degrade device reliability. These are stress ratings only, and functional operation of the device at these or any other conditions beyond those specified is not supported.
- (2) Input terminals are diode-clamped to the power-supply rails. Input signals that can swing more than 0.5V beyond the supply rails should be current limited to 10mA or less.
- (3) Short-circuit to ground, one amplifier per package.

PACKAGE/ORDERING INFORMATION(1)

PRODUCT	PACKAGE-LEAD	PACKAGE DESIGNATOR(1)	SPECIFIED TEMPERATURE RANGE	PACKAGE MARKING	ORDERING NUMBER	TRANSPORT MEDIA, QUANTITY
OPA357 "	SO-8 PowerPAD "	DDA "	-40°C to +125°C "	OPA357A "	OPA357AIDDA OPA357AIDDAR	Rails, 97 Tape and Reel, 2500
OPA357 "	SOT23-6 "	DBV "	-40°C to +125°C "	OADI "	OPA357AIDBVT OPA357AIDBVR	Tape and Reel, 250 Tape and Reel, 3000
OPA2357 "	MSOP-10 "	DGS "	-40°C to +125°C "	BBG "	OPA2357AIDGST OPA2357AIDGSR	Tape and Reel, 250 Tape and Reel, 2500

(1) For the most current package and ordering information, see the Package Option Addendum located at the end of this data sheet.

PIN CONFIGURATION

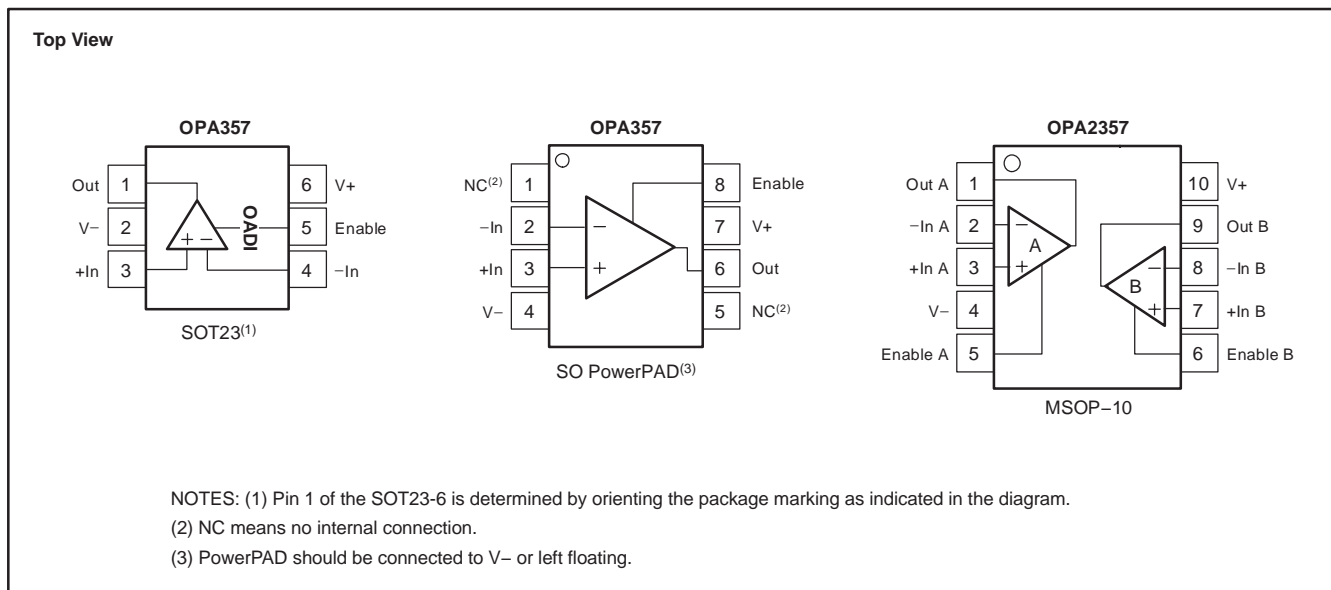

ELECTRICAL CHARACTERISTICS: $V_S = +2.7V$ to $+5.5V$ Single-Supply

Boldface limits apply over the temperature range, $T_A = -40^\circ C$ to $+125^\circ C$.

All specifications at $T_A = +25^\circ C$, $R_F = 0\Omega$, $R_L = 1k\Omega$ connected to $V_S/2$, unless otherwise noted.

PARAMETER	CONDITIONS	OPA357AI OPA2357AI			UNITS
		MIN	TYP	MAX	
OFFSET VOLTAGE					
Input Offset Voltage	V_{OS}		± 2	± 8	mV
vs Temperature	dV_{OS}/dT		± 4	± 10	mV/ $^\circ C$
vs Power Supply	PSRR	$V_S = +2.7V$ to $+5.5V$, $V_{CM} = (V_S/2) - 0.15V$ Specified Temperature Range	± 200	± 800	$\mu V/V$
				± 900	$\mu V/V$
INPUT BIAS CURRENT					
Input Bias Current	I_B		3	± 50	pA
Input Offset Current	I_{OS}		± 1	± 50	pA
NOISE					
Input Voltage Noise Density	e_n	$f = 1MHz$		6.5	nV/\sqrt{Hz}
Current Noise Density	i_n	$f = 1MHz$		50	fA/\sqrt{Hz}
INPUT VOLTAGE RANGE					
Common-Mode Voltage Range	V_{CM}		$(V-) - (0.1)$		V
Common-Mode Rejection Ratio	CMRR	$V_S = +5.5V$, $-0.1V < V_{CM} < +3.5V$ Specified Temperature Range	66	80	dB
		$V_S = +5.5V$, $-0.1V < V_{CM} < +5.6V$ Specified Temperature Range	64	68	dB
			56		dB
			55		dB
INPUT IMPEDANCE					
Differential				$10^{13} \parallel 2$	$\Omega \parallel pF$
Common-Mode				$10^{13} \parallel 2$	$\Omega \parallel pF$
OPEN-LOOP GAIN	A_{OL}	$V_S = +5V$, $+0.3V < V_O < +4.7V$	94	110	dB
Specified Temperature Range		$V_S = +5V$, $+0.4V < V_O < +4.6V$	90		dB
FREQUENCY RESPONSE					
Small-Signal Bandwidth	f_{-3dB}	$G = +1$, $V_O = 100mV_{pp}$, $R_F = 25\Omega$		250	MHz
	f_{-3dB}	$G = +2$, $V_O = 100mV_{pp}$		90	MHz
Gain-Bandwidth Product	GBW	$G = +10$		100	MHz
Bandwidth for 0.1dB Gain Flatness	$f_{0.1dB}$	$G = +2$, $V_O = 100mV_{pp}$		40	MHz
Slew Rate	SR	$V_S = +5V$, $G = +1$, 4V Step		150	V/ μs
		$V_S = +5V$, $G = +1$, 2V Step		130	V/ μs
		$V_S = +3V$, $G = +1$, 2V Step		110	V/ μs
Rise-and-Fall Time		$G = +1$, $V_O = 200mV_{pp}$, 10% to 90%		2	ns
		$G = 1$, $V_O = 2V_{pp}$, 10% to 90%		11	ns
Settling Time, 0.1%		$V_S = +5V$, $G = +1$, 2V Output Step		30	ns
0.01%				60	ns
Overload Recovery Time		$V_{IN} \cdot Gain = V_S$		5	ns
Harmonic Distortion					
2nd-Harmonic		$G = +1$, $f = 1MHz$, $V_O = 2V_{pp}$, $R_L = 200\Omega$, $V_{CM} = 1.5V$		-75	dBc
3rd-Harmonic		$G = +1$, $f = 1MHz$, $V_O = 2V_{pp}$, $R_L = 200\Omega$, $V_{CM} = 1.5V$		-83	dBc
Differential Gain Error		NTSC, $R_L = 150\Omega$		0.02	%
Differential Phase Error		NTSC, $R_L = 150\Omega$		0.09	degrees
Channel-to-Channel Crosstalk, OPA2357		$f = 5MHz$		-100	dB
OUTPUT					
Voltage Output Swing from Rail		$V_S = +5V$, $R_L = 1k\Omega$, $A_{OL} > 94dB$		0.1	V
Specified Temperature Range		$V_S = +5V$, $R_L = 1k\Omega$, $A_{OL} > 90dB$		0.4	V
Output Current ⁽¹⁾⁽²⁾ , Single, Dual	I_O	$V_S = +5V$	100		mA
		$V_S = +3V$		50	mV
Closed-Loop Output Impedance		$f < 100kHz$		0.05	Ω
Open-Loop Output Resistance	R_O			35	Ω

(1) See typical characteristics *Output Voltage Swing vs Output Current*.

(2) Specified by design.

ELECTRICAL CHARACTERISTICS: $V_S = +2.7V$ to $+5.5V$ Single-Supply (continued)

Boldface limits apply over the temperature range, $T_A = -40^{\circ}C$ to $+125^{\circ}C$.

All specifications at $T_A = +25^{\circ}C$, $R_F = 0\Omega$, $R_L = 1k\Omega$ connected to $V_S/2$, unless otherwise noted.

PARAMETER	CONDITIONS	OPA357AI OPA2357AI			UNITS
		MIN	TYP	MAX	
POWER SUPPLY					
Specified Voltage Range	V_S	2.7		5.5	V
Operating Voltage Range			2.5 to 5.5		V
Quiescent Current (per amplifier)	I_Q $V_S = +5V$, Enabled, $I_O = 0$ Specified Temperature Range		4.9	6 7.5	mA mA
ENABLE/SHUTDOWN FUNCTION					
Disabled (logic–LOW Threshold)				0.8	V
Enabled (logic–HIGH Threshold)		2			V
Logic Input Current	Logic LOW		200		nA
Turn-On Time			100		ns
Turn-Off Time			30		ns
Off Isolation	$G = +1$, 5MHz, $R_L = 10\Omega$		74		dB
Quiescent Current (per amplifier)			3.4	6	μA
THERMAL SHUTDOWN					
Junction Temperature	T_J				
Shutdown			+160		$^{\circ}C$
Reset from Shutdown			+140		$^{\circ}C$
TEMPERATURE RANGE					
Specified Range		-40		+125	$^{\circ}C$
Operating Range		-55		+150	$^{\circ}C$
Storage Range		-65		+150	$^{\circ}C$
Thermal Resistance	θ_{JA}				$^{\circ}C/W$
SOT23-6			150		$^{\circ}C/W$
SO-8 PowerPAD			65		$^{\circ}C/W$
MSOP-10			150		$^{\circ}C/W$

(1) See typical characteristics *Output Voltage Swing vs Output Current*.

(2) Specified by design.

TYPICAL CHARACTERISTICS

At $T_A = +25^\circ\text{C}$, $V_S = 5\text{V}$, $G = +1$, $R_F = 0\Omega$, $R_L = 1\text{k}\Omega$, and connected to $V_S/2$, unless otherwise noted.

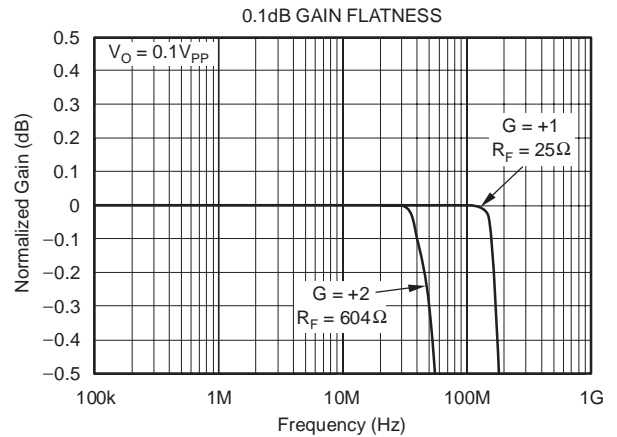
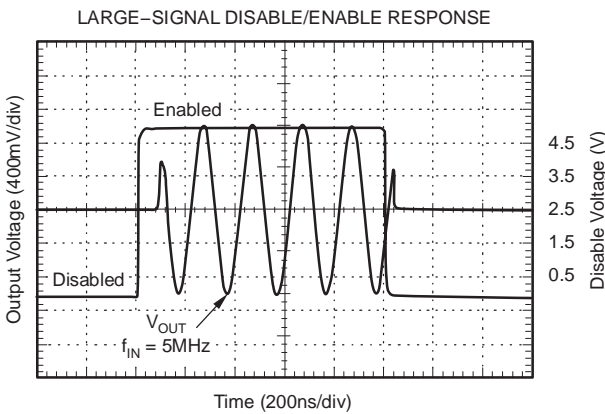
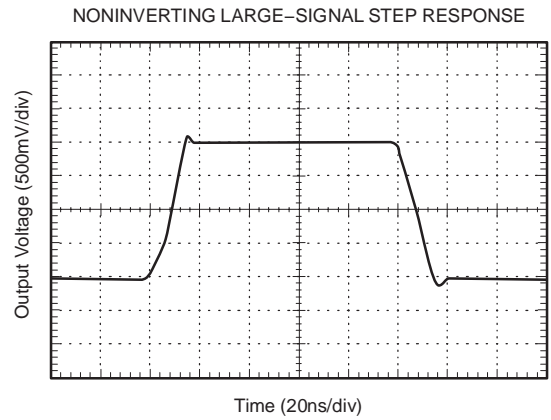
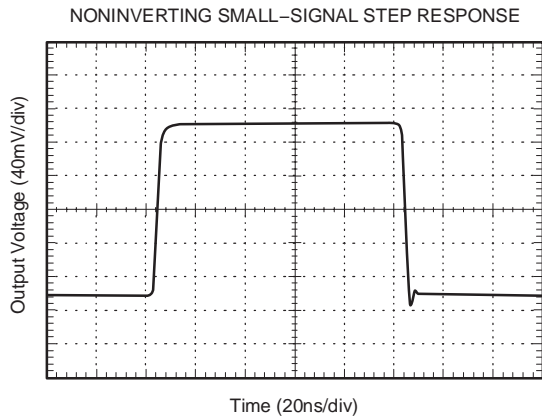
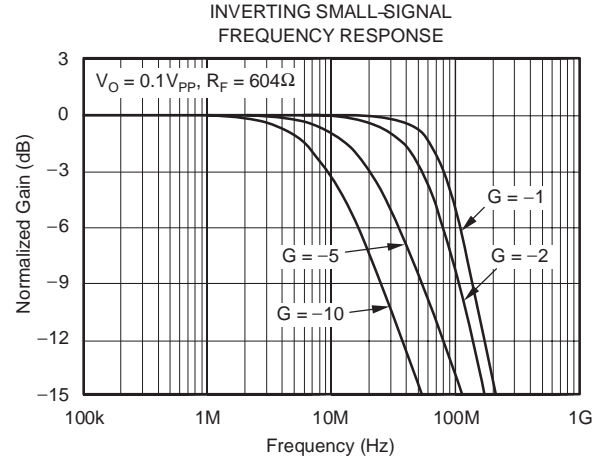
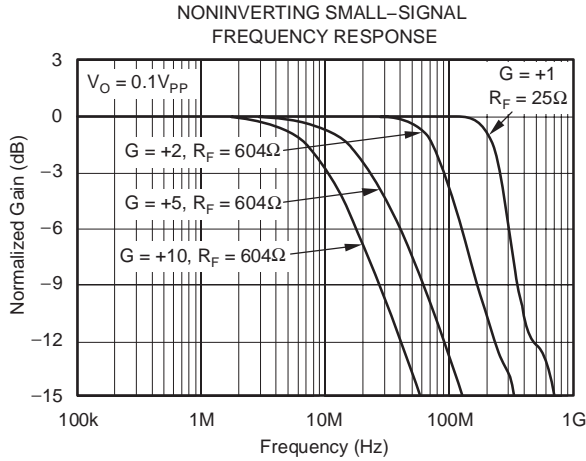

TYPICAL CHARACTERISTICS (continued)

At $T_A = +25^\circ\text{C}$, $V_S = 5\text{V}$, $G = +1$, $R_F = 0\Omega$, $R_L = 1\text{k}\Omega$, and connected to $V_S/2$, unless otherwise noted.

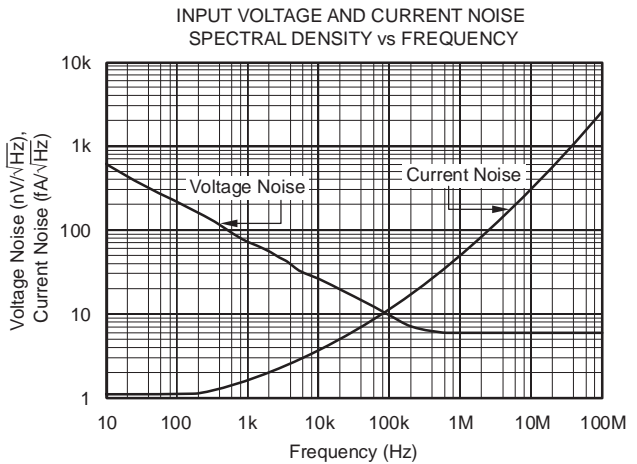
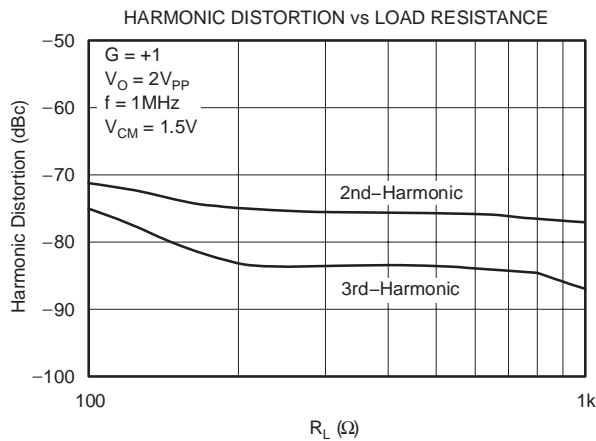
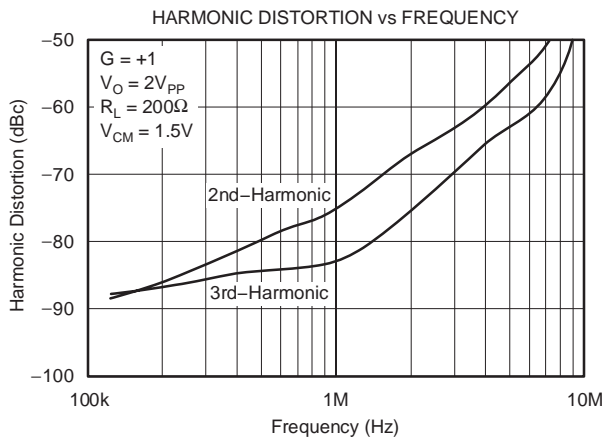
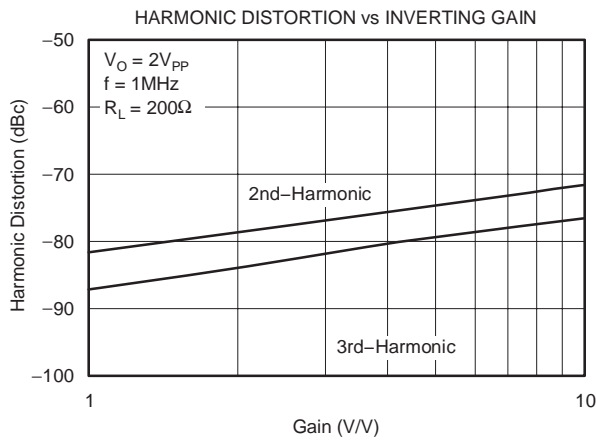
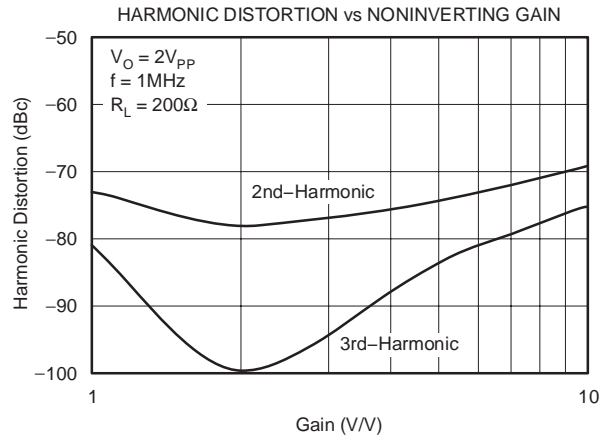
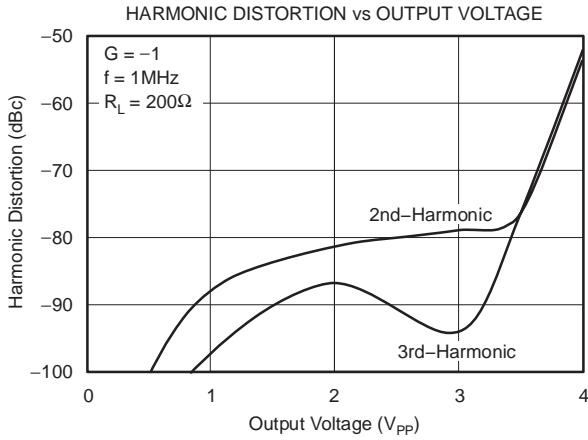

TYPICAL CHARACTERISTICS (continued)

At $T_A = +25^\circ\text{C}$, $V_S = 5\text{V}$, $G = +1$, $R_F = 0\Omega$, $R_L = 1\text{k}\Omega$, and connected to $V_S/2$, unless otherwise noted.

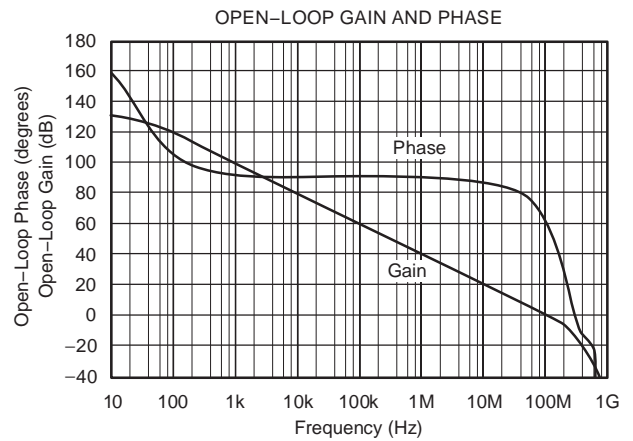
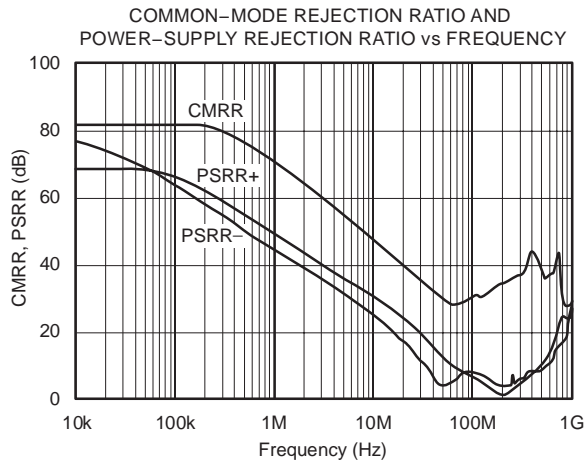
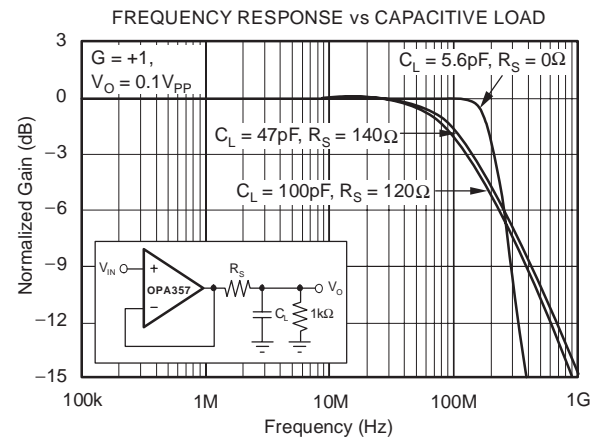
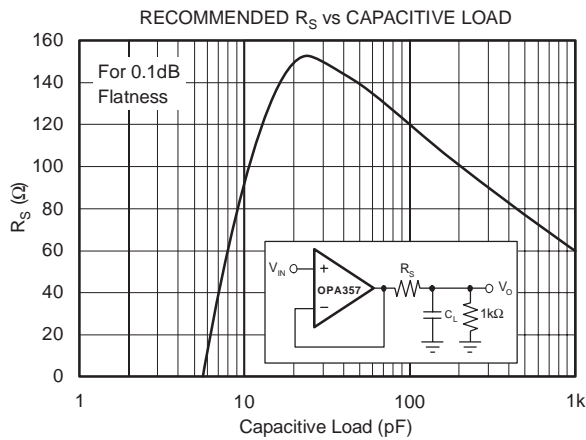
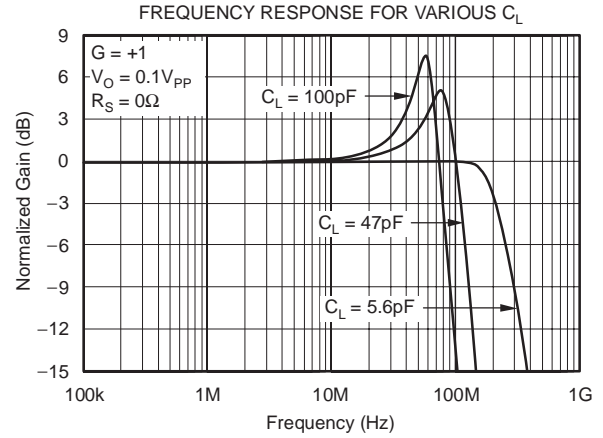
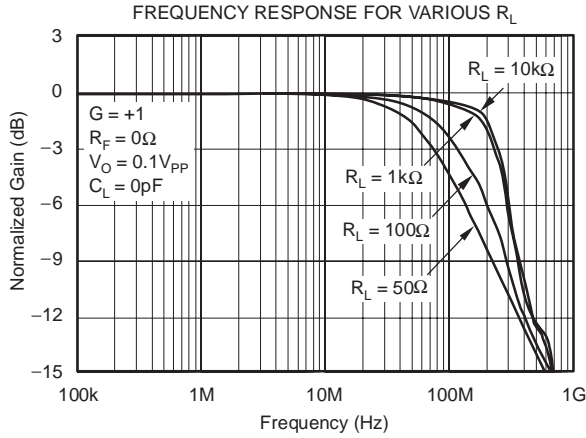

TYPICAL CHARACTERISTICS (continued)

At $T_A = +25^\circ\text{C}$, $V_S = 5\text{V}$, $G = +1$, $R_F = 0\Omega$, $R_L = 1\text{k}\Omega$, and connected to $V_S/2$, unless otherwise noted.

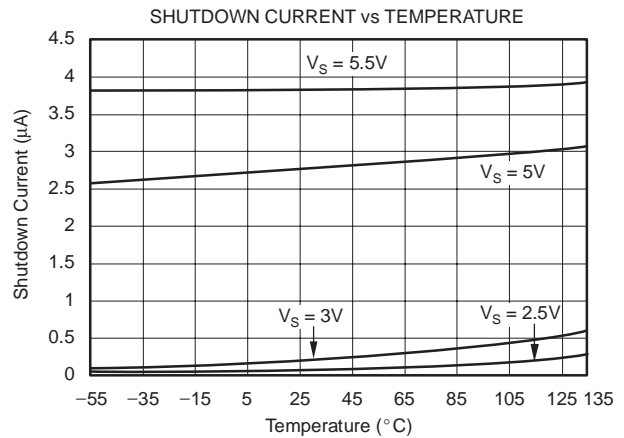
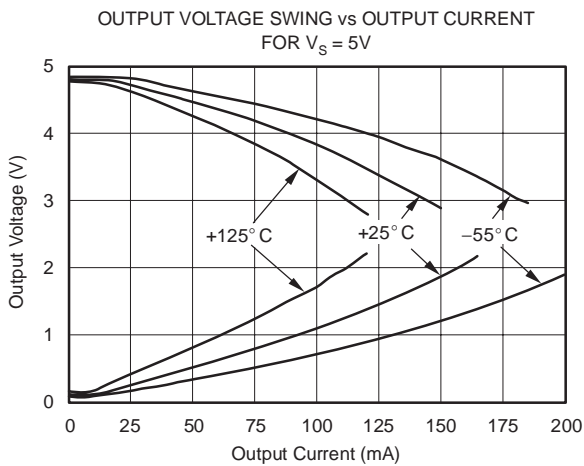
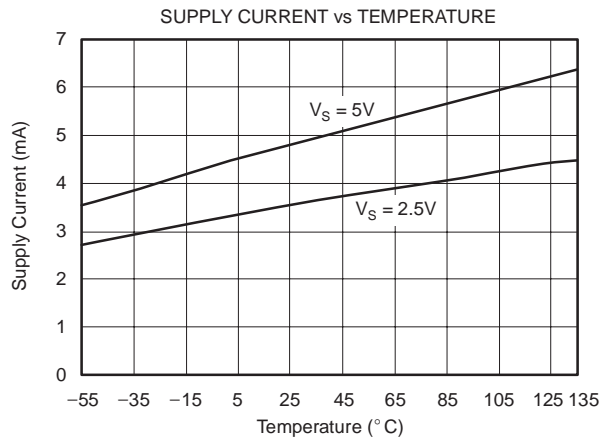
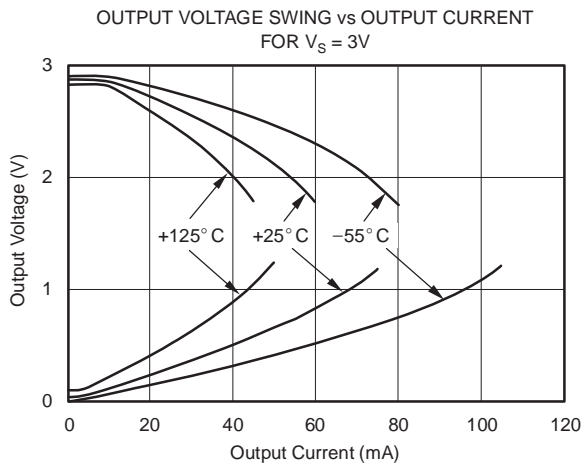
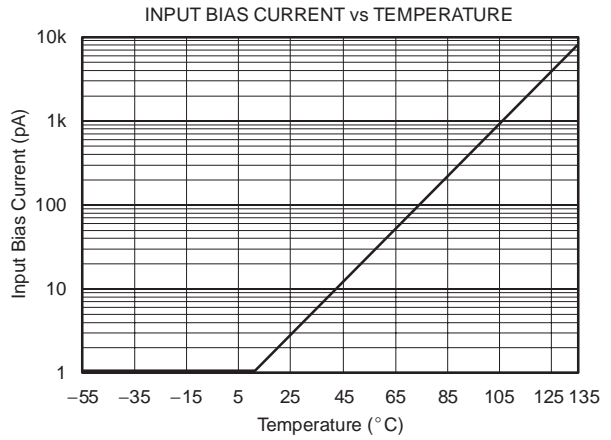
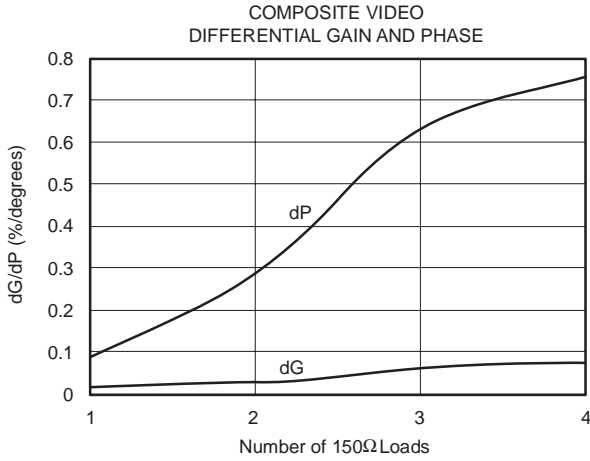

TYPICAL CHARACTERISTICS (continued)

At $T_A = +25^\circ\text{C}$, $V_S = 5\text{V}$, $G = +1$, $R_F = 0\Omega$, $R_L = 1\text{k}\Omega$, and connected to $V_S/2$, unless otherwise noted.

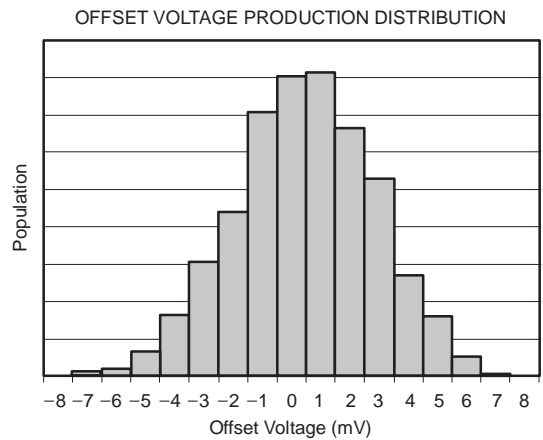
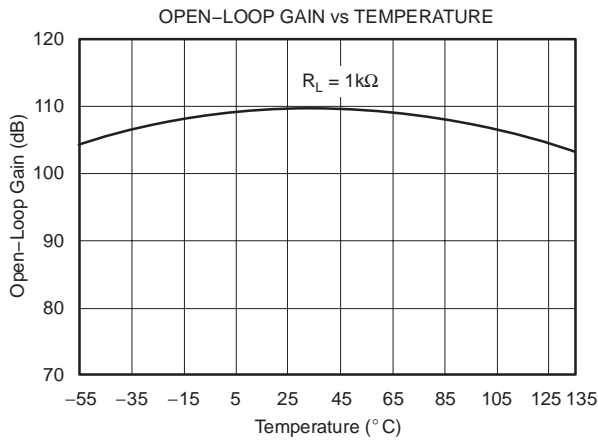
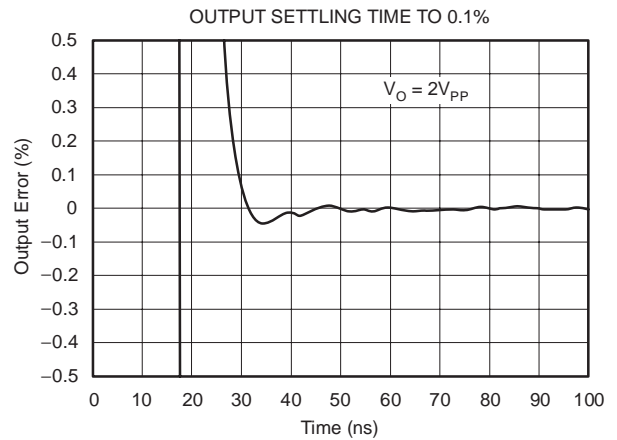
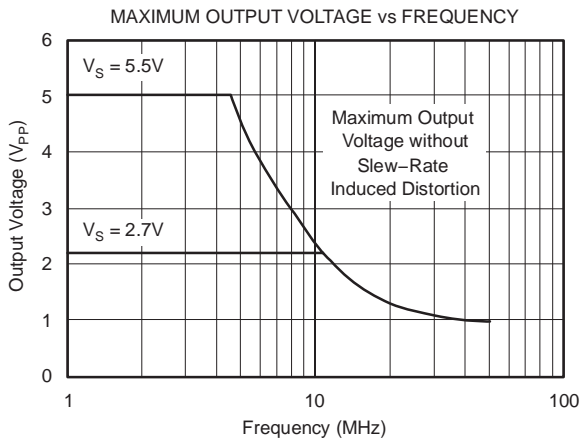
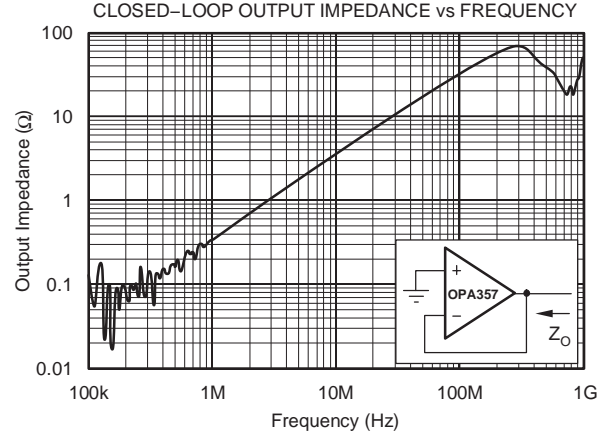
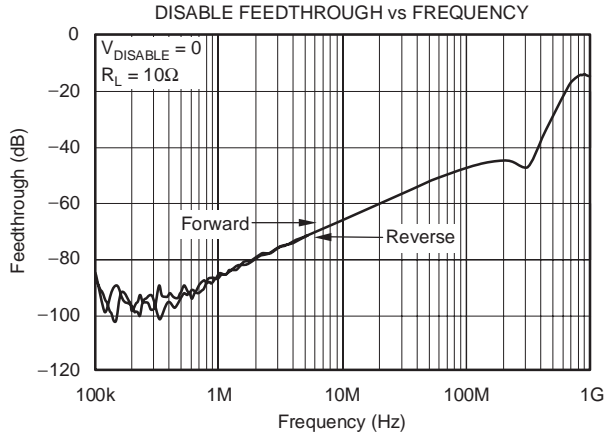

TYPICAL CHARACTERISTICS (continued)

At $T_A = +25^\circ\text{C}$, $V_S = 5\text{V}$, $G = +1$, $R_F = 0\Omega$, $R_L = 1\text{k}\Omega$, and connected to $V_S/2$, unless otherwise noted.

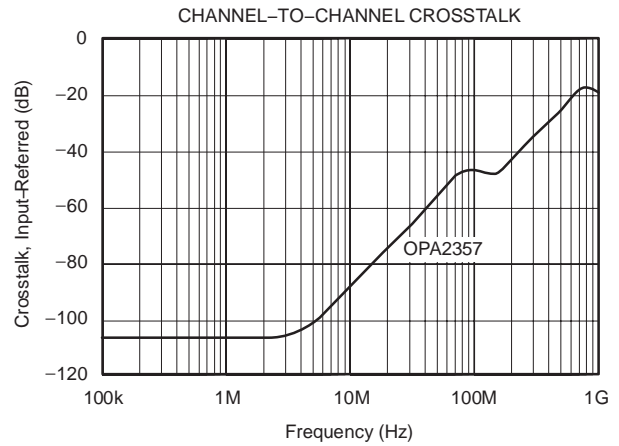
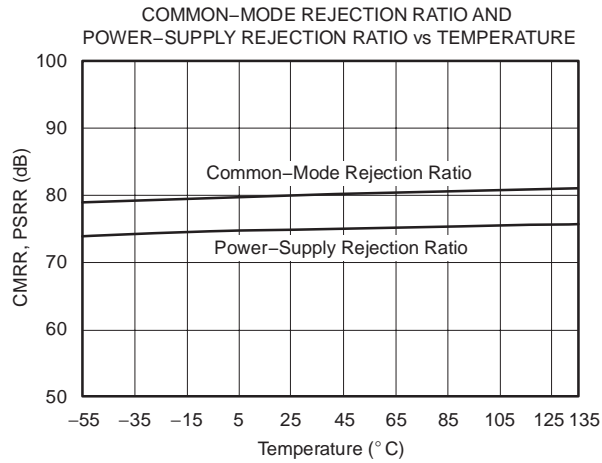

APPLICATIONS INFORMATION

The OPA357 is a CMOS, rail-to-rail I/O, high-speed, voltage-feedback operational amplifier designed for video, high-speed, and other applications. It is available as a single or dual op amp.

The amplifier features a 100MHz gain bandwidth, and 150V/ μ s slew rate, but it is unity-gain stable and can be operated as a +1V/V voltage follower.

OPERATING VOLTAGE

The OPA357 is specified over a power-supply range of +2.7V to +5.5V (± 1.35 V to ± 2.75 V). However, the supply voltage may range from +2.5V to +5.5V (± 1.25 V to ± 2.75 V). Supply voltages higher than 7.5V (absolute maximum) can permanently damage the amplifier.

Parameters that vary over supply voltage or temperature are shown in the Typical Characteristics section of this data sheet.

ENABLE FUNCTION

The OPA357's Enable function is implemented using a Schmitt trigger. The amplifier is enabled by applying a TTL HIGH voltage level (referenced to V_-) to the Enable pin. Conversely, a TTL LOW voltage level (referenced to V_-) will disable the amplifier, reducing its supply current from 4.9mA to only 3.4 μ A per amplifier. Independent Enable pins are available for each channel (dual version), providing maximum design flexibility. For portable battery-operated applications, this feature can be used to greatly reduce the average current and thereby extend battery life.

The Enable input can be modeled as a CMOS input gate with a 100k Ω pull-up resistor to V_+ . This pin should be connected to a valid high or low voltage or driven, not left open circuit.

The enable time is 100ns and the disable time is only 30ns. This allows the OPA357 to be operated as a *gated* amplifier, or to have its output multiplexed onto a common output bus. When disabled, the output assumes a high-impedance state.

RAIL-TO-RAIL INPUT

The specified input common-mode voltage range of the OPA357 extends 100mV beyond the supply rails. This is achieved with a complementary input stage—an N-channel input differential pair in parallel with a P-channel differential pair, as shown in Figure 1. The N-channel pair is active for input voltages close to the positive rail, typically $(V_+) - 1.2$ V to 100mV above the positive supply, while the P-channel pair is on for inputs from 100mV below the negative supply to approximately $(V_+) - 1.2$ V. There is a small transition region, typically $(V_+) - 1.5$ V to $(V_+) - 0.9$ V, in which both pairs are on. This 600mV transition region can vary ± 500 mV with process variation. Thus, the transition region (both input stages on) can range from $(V_+) - 2.0$ V to $(V_+) - 1.5$ V on the low end, up to $(V_+) - 0.9$ V to $(V_+) - 0.4$ V on the high end.

A double-folded cascode adds the signal from the two input pairs and presents a differential signal to the class AB output stage.

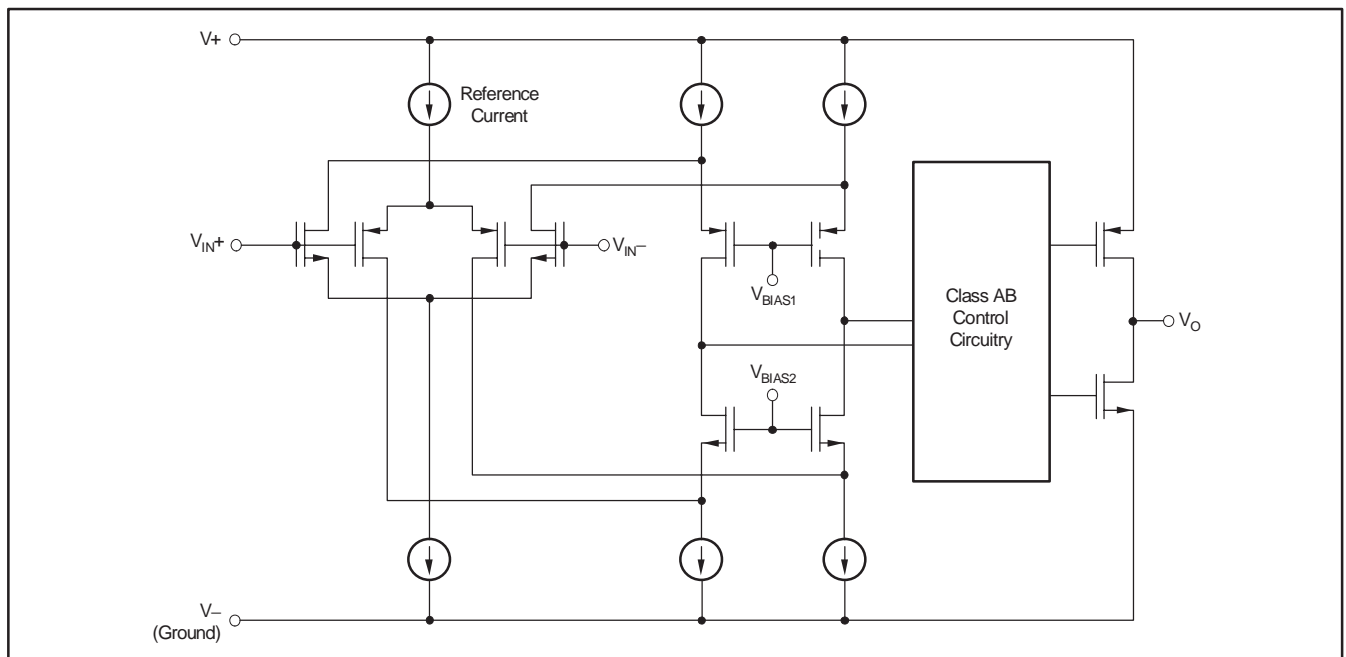

Figure 1. Simplified Schematic

RAIL-TO-RAIL OUTPUT

A class AB output stage with common-source transistors is used to achieve rail-to-rail output. For high-impedance loads ($> 200\Omega$), the output voltage swing is typically 100mV from the supply rails. With 10Ω loads, a useful output swing can be achieved while maintaining high open-loop gain. See the typical characteristic curve *Output Voltage Swing vs Output Current*.

OUTPUT DRIVE

The OPA357's output stage can supply a continuous output current of $\pm 100\text{mA}$ and still provide approximately 2.7V of output swing on a 5V supply, as shown in Figure 2. For maximum reliability, it is not recommended to run a continuous DC current in excess of $\pm 100\text{mA}$. Refer to the typical characteristic curve *Output Voltage Swing vs Output Current*. For supplying continuous output currents greater than $\pm 100\text{mA}$, the OPA357 may be operated in parallel as shown in Figure 3.

The OPA357 will provide peak currents up to 200mA, which corresponds to the typical short-circuit current. Therefore, an on-chip thermal shutdown circuit is provided to protect the OPA357 from dangerously high junction temperatures. At 160°C , the protection circuit will shut down the amplifier. Normal operation will resume when the junction temperature cools to below 140°C .

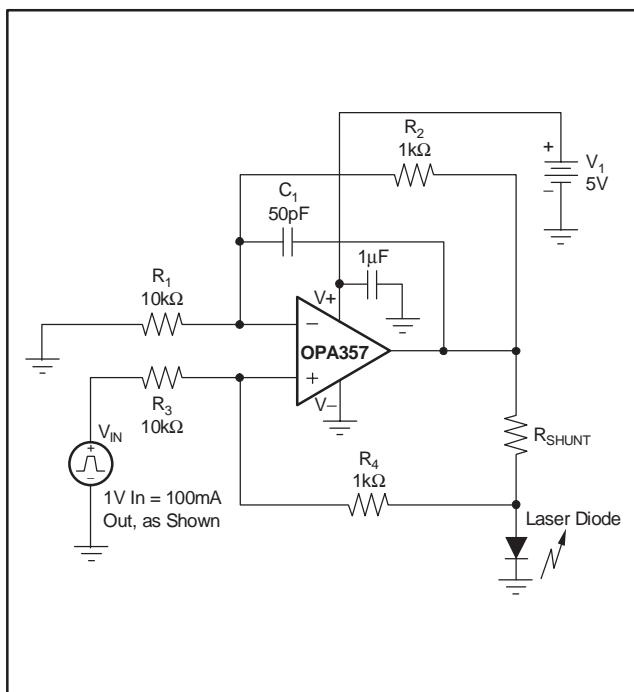

Figure 2. Laser Diode Driver

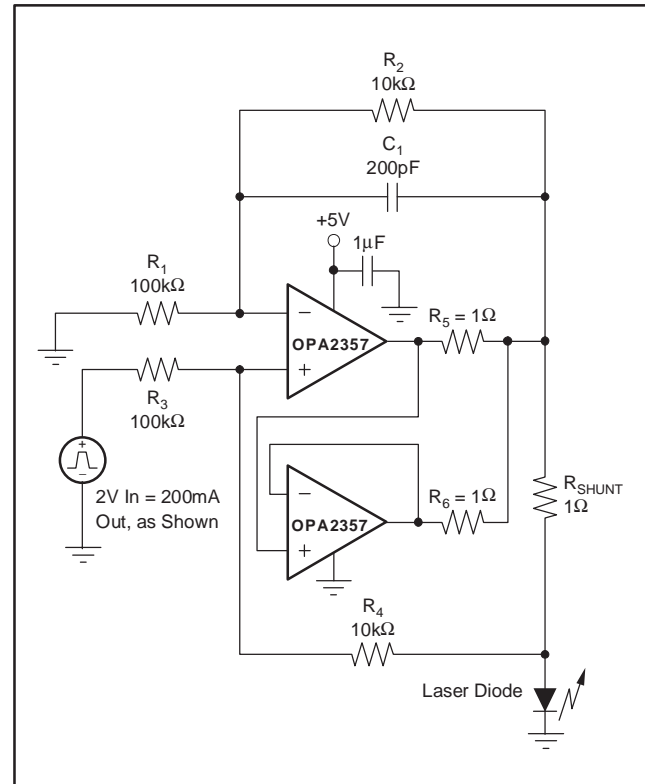

Figure 3. Parallel Operation

VIDEO

The OPA357 output stage is capable of driving standard back-terminated 75Ω video cables, as shown in Figure 4. By back-terminating a transmission line, it does not exhibit a capacitive load to its driver. A properly back-terminated 75Ω cable does not appear as capacitance; it presents only a 150Ω resistive load to the OPA357 output.

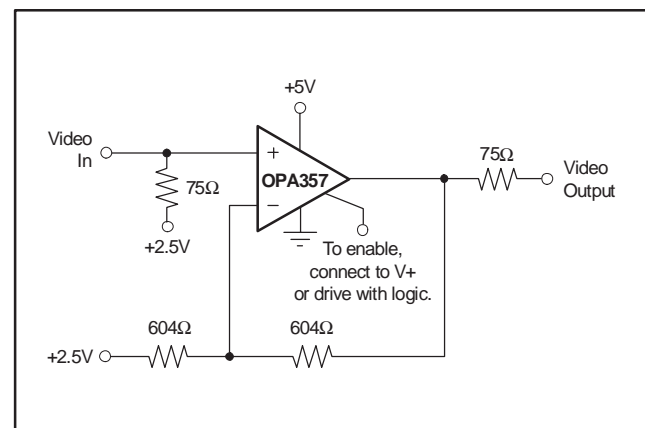

Figure 4. Single-Supply Video Line Driver

The OPA357 can be used as an amplifier for RGB graphic signals, which have a voltage of zero at the video black level, by offsetting and AC-coupling the signal. See Figure 5.

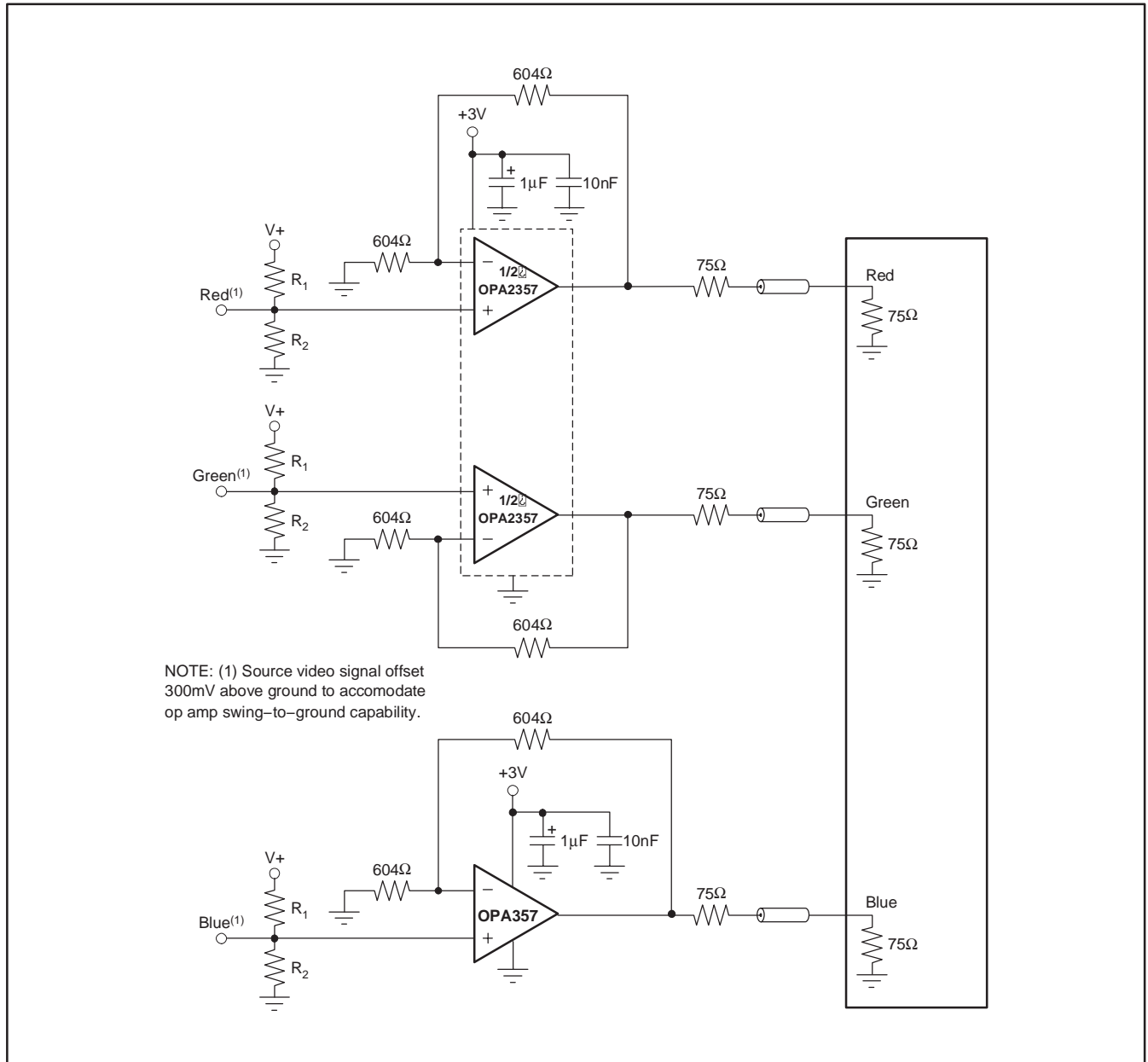

Figure 5. RGB Cable Driver

WIDEBAND VIDEO MULTIPLEXING

One common application for video speed amplifiers which include an enable pin is to wire multiple amplifier outputs together, then select which one of several possible video

inputs to source onto a single line. This simple *Wired-OR Video Multiplexer* can be easily implemented using the OPA357; see Figure 6.

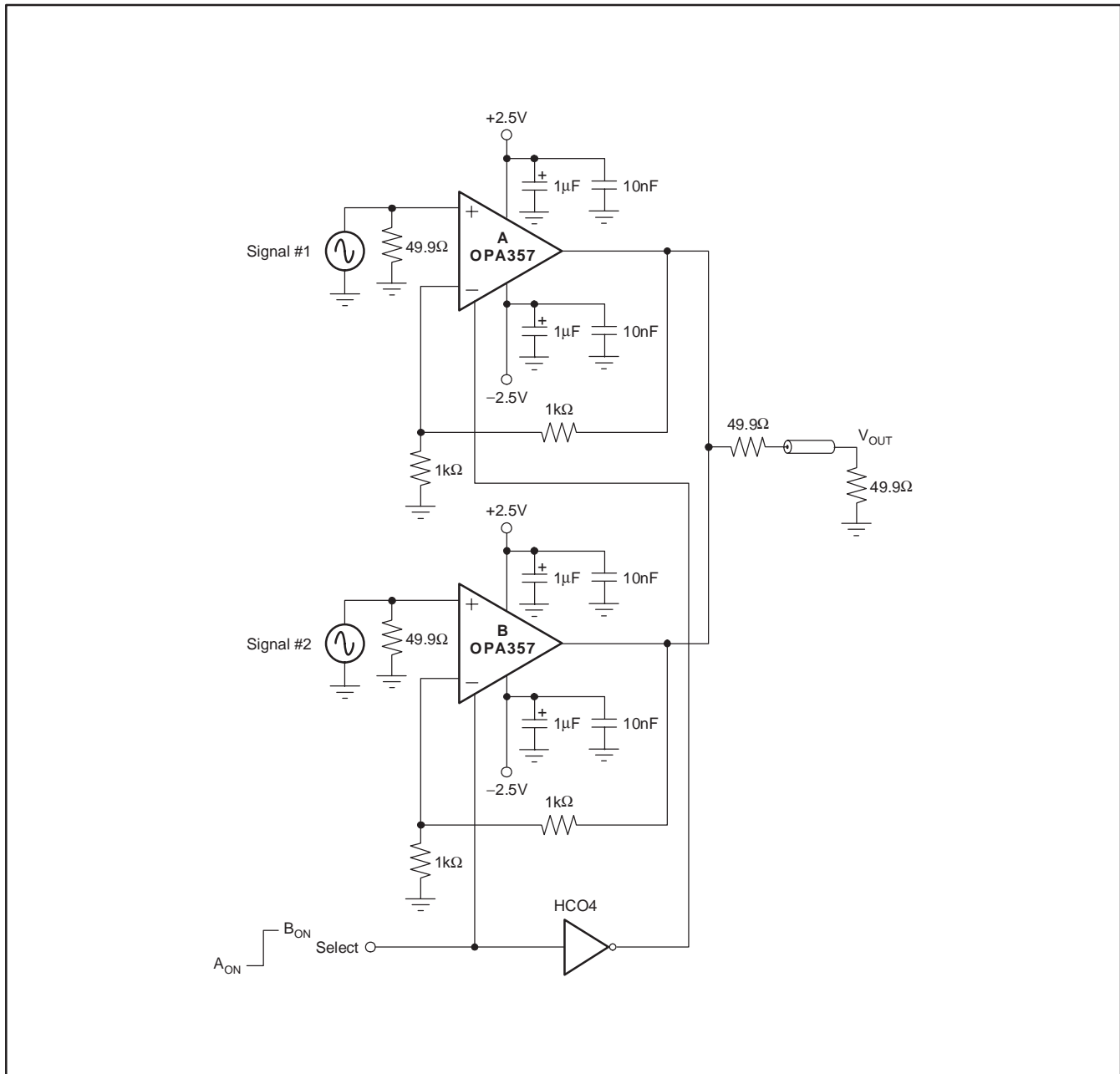

Figure 6. Multiplexed Output

DRIVING ANALOG-TO-DIGITAL CONVERTERS

The OPA357 series op amps offer 60ns of settling time to 0.01%, making them a good choice for driving high- and medium-speed sampling A/D converters and reference circuits. The OPA357 series provide an effective means of buffering the A/D converter's input capacitance and resulting charge injection while providing signal gain.

See Figure 7 for the OPA357 driving an A/D converter. With the OPA357 in an inverting configuration, a capacitor across the feedback resistor can be used to filter high-frequency noise in the signal; see Figure 7.

CAPACITIVE LOAD AND STABILITY

The OPA357 series op amps can drive a wide range of capacitive loads. However, all op amps under certain conditions may become unstable. Op amp configuration, gain, and load value are just a few of the factors to consider when determining stability. An op amp in unity-gain configuration is most susceptible to the effects of capacitive loading. The capacitive load reacts with the op amp's output resistance, along with any additional load

resistance, to create a pole in the small-signal response that degrades the phase margin. Refer to the typical characteristic curve *Frequency Response for Various C_L* for details.

The OPA357's topology enhances its ability to drive capacitive loads. In unity gain, these op amps perform well with large capacitive loads. Refer to the typical characteristic curves *Recommended R_S vs Capacitive Load* and *Frequency Response vs Capacitive Load* for details.

One method of improving capacitive load drive in the unity-gain configuration is to insert a 10Ω to 20Ω resistor in series with the output, as shown in Figure 8. This significantly reduces ringing with large capacitive loads—see the typical characteristic curve *Frequency Response vs Capacitive Load*. However, if there is a resistive load in parallel with the capacitive load, R_S creates a voltage divider. This introduces a DC error at the output and slightly reduces output swing. This error may be insignificant. For instance, with $R_L = 10k\Omega$ and $R_S = 20\Omega$, there is only about a 0.2% error at the output.

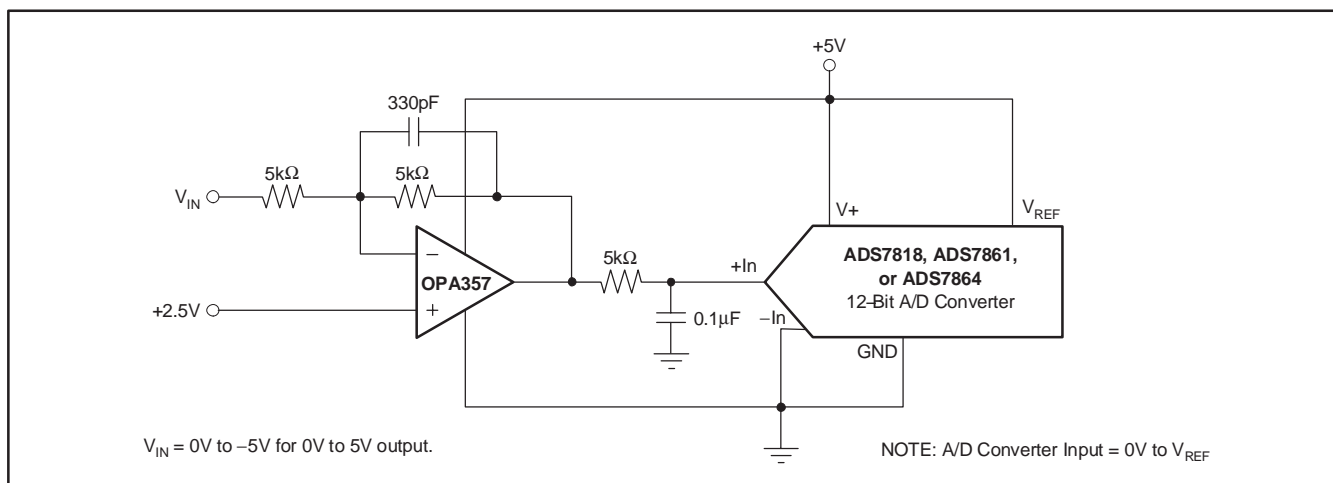

Figure 7. The OPA357 in Inverting Configuration Driving an A/D Converter

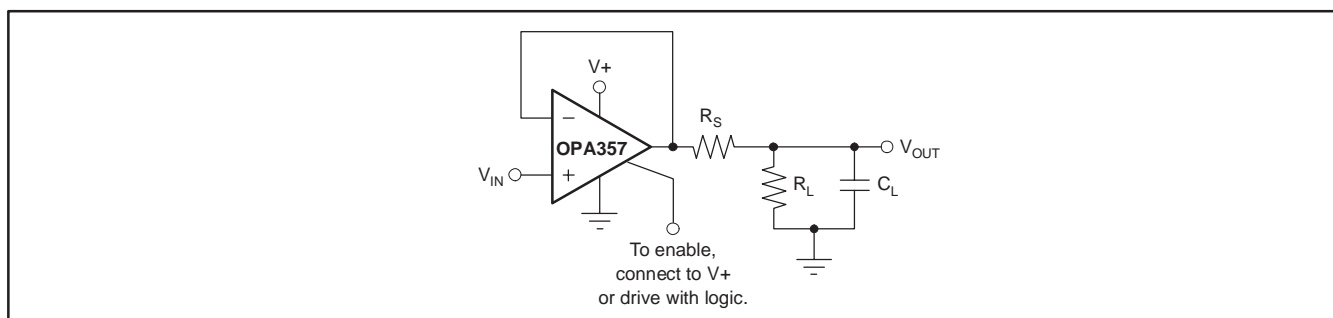

Figure 8. Series Resistor in Unity-Gain Configuration Improves Capacitive Load Drive

WIDEBAND TRANSIMPEDANCE AMPLIFIER

Wide bandwidth, low input bias current, and low input voltage and current noise make the OPA357 an ideal wideband photodiode transimpedance amplifier for low-voltage single-supply applications. Low-voltage noise is important because photodiode capacitance causes the effective noise gain of the circuit to increase at high frequency.

The key elements to a transimpedance design, as shown in Figure 9, are the expected diode capacitance (including the parasitic input common-mode and differential-mode input capacitance (2 + 2)pF for the OPA357), the desired transimpedance gain (R_F), and the Gain Bandwidth Product (GBP) for the OPA357 (100MHz). With these 3 variables set, the feedback capacitor value (C_F) may be set to control the frequency response.

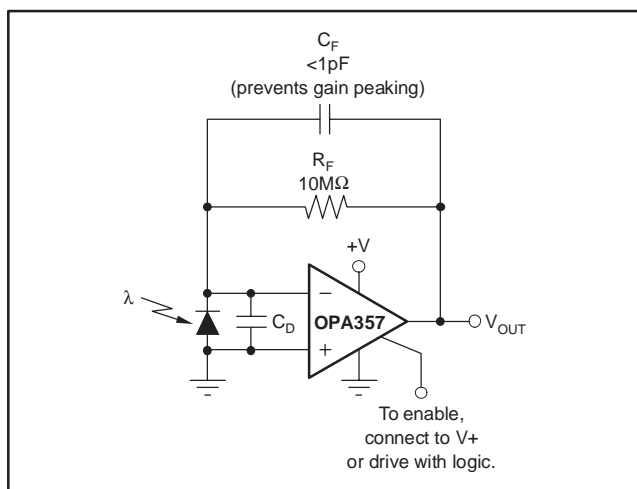

Figure 9. Transimpedance Amplifier

To achieve a maximally flat 2nd-order Butterworth frequency response, the feedback pole should be set to:

$$\frac{1}{2\pi R_F C_F} = \sqrt{\frac{\text{GBP}}{4\pi R_F C_D}} \quad (1)$$

Typical surface-mount resistors have a parasitic capacitance of around 0.2pF that must be deducted from the calculated feedback capacitance value.

Bandwidth is calculated by:

$$f_{-3\text{dB}} = \sqrt{\frac{\text{GBP}}{2\pi R_F C_D}} \text{ Hz} \quad (2)$$

For even higher transimpedance bandwidth, the high-speed CMOS OPA355 (200MHz GBW) or the OPA655 (400MHz GBW) may be used.

PCB LAYOUT

Good high-frequency printed circuit board (PCB) layout techniques should be employed for the OPA357. Generous use of ground planes, short and direct signal traces, and a suitable bypass capacitor located at the V+ pin will assure clean, stable operation. Large areas of copper also provides a means of dissipating heat that is generated in normal operation.

Sockets are definitely not recommended for use with any high-speed amplifier.

A 10nF ceramic bypass capacitor is the minimum recommended value; adding a 1μF or larger tantalum capacitor in parallel can be beneficial when driving a low-resistance load. Providing adequate bypass capacitance is essential to achieving very low harmonic and intermodulation distortion.

POWER DISSIPATION

Besides the regular SOT23-6 and MSOP-10, the single and dual versions of the OPA357 also come in an SO-8 PowerPAD. The SO-8 PowerPAD is a standard-size SO-8 package where the exposed leadframe on the bottom of the package is soldered directly to the PCB to create an extremely low thermal resistance. This will enhance the OPA357's power dissipation capability significantly and eliminates the use of bulky heatsinks and slugs traditionally used in thermal packages. This package can be easily mounted using standard PCB assembly techniques. NOTE: Since the SO-8 PowerPAD is pin-compatible with standard SO-8 packages, the OPA357 can directly replace operational amplifiers in existing sockets. Soldering the PowerPAD to the PCB is always recommended, even with applications that have low power dissipation. This provides the necessary thermal and mechanical connection between the leadframe die pad and the PCB.

For resistive loads, the maximum power dissipation occurs at a DC output voltage of one-half the power-supply voltage. Dissipation with AC signals is lower. Application Bulletin AB-039 (SBOA022), *Power Amplifier Stress and Power Handling Limitations*, explains how to calculate or measure power dissipation with unusual signals and loads, and can be found at www.ti.com.

Any tendency to activate the thermal protection circuit indicates excessive power dissipation or an inadequate heat sink. For reliable operation, junction temperature should be limited to 150°C, maximum. To estimate the margin of safety in a complete design, increase the ambient temperature until the thermal protection is triggered at 160°C. The thermal protection should trigger more than 35°C above the maximum expected ambient condition of your application.

PowerPAD THERMALLY ENHANCED PACKAGE

The OPA357 uses the SO-8 PowerPAD package, a thermally enhanced, standard size IC package designed to eliminate the use of bulky heatsinks and slugs traditionally used in thermal packages. This package can be easily mounted using standard PCB assembly techniques.

The PowerPAD package is designed so that the leadframe die pad (or thermal pad) is exposed on the bottom of the IC, as shown in Figure 10. This provides an extremely low thermal resistance (θ_{JC}) path between the die and the exterior of the package. The thermal pad on the bottom of the IC is then soldered directly to the PCB, using the PCB as a heatsink. In addition, plated-through holes (vias) provide a low thermal resistance heat flow path to the back side of the PCB.

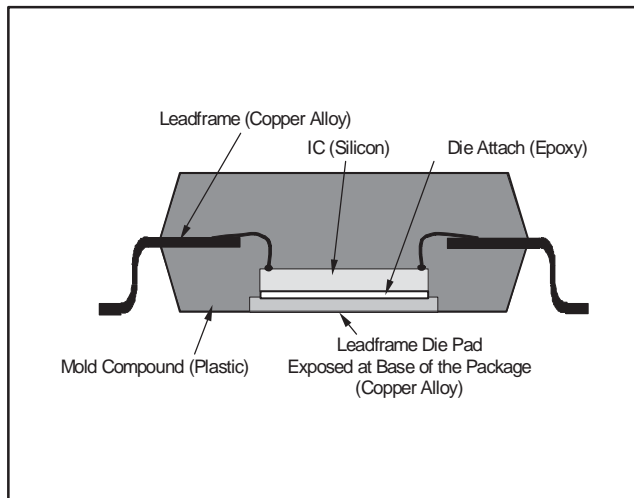

Figure 10. Section View of a PowerPAD Package

PowerPAD ASSEMBLY PROCESS

1. The PowerPAD must be connected to the device's most negative supply voltage, which will be ground in single-supply applications, and V^- in split-supply applications.
2. Prepare the PCB with a top-side etch pattern, as shown in Figure 11. The exact land design may vary based on the specific assembly process requirements. There should be etch for the leads as well as etch for the thermal land.

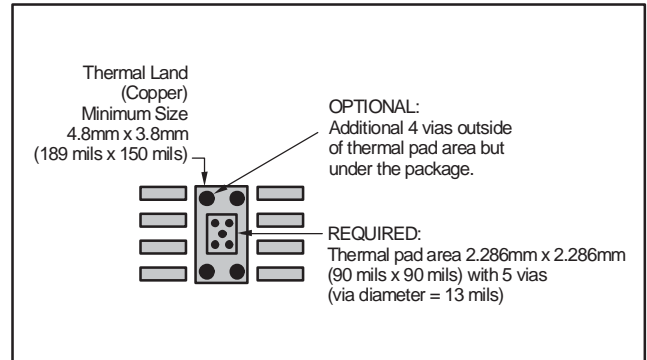

Figure 11. 8-Pin PowerPAD PCB Etch and Via Pattern

3. Place the recommended number of plated-through holes (or thermal vias) in the area of the thermal pad. These holes should be 13 mils in diameter. They are kept small so that solder wicking through the holes is not a problem during reflow. The minimum recommended number of holes for the SO-8 PowerPAD package is 5, as shown in Figure 11.
4. It is recommended, but not required, to place a small number of additional holes under the package and outside the thermal pad area. These holes provide additional heat paths between the copper thermal land and the ground plane. They may be larger because they are not in the area to be soldered, so wicking is not a problem. This is illustrated in Figure 11.

5. Connect all holes, including those within the thermal pad area and outside the pad area, to the internal ground plane or other internal copper plane for single-supply applications, and to V– for split-supply applications.

6. When laying out these holes, do not use the typical web or spoke via connection methodology, as shown in Figure 12. Web connections have a high thermal resistance connection that is useful for slowing the heat transfer during soldering operations. This makes soldering the vias that have ground plane connections easier. However, in this application, low thermal resistance is desired for the most efficient heat transfer. Therefore, the holes under the PowerPAD package should make their connection to the internal ground plane with a complete connection around the entire circumference of the plated-through hole.

7. The top-side solder mask should leave the pad connections and the thermal pad area exposed. The thermal pad area should leave the 13 mil holes exposed. The larger holes outside the thermal pad area may be covered with solder mask.

8. Apply solder paste to the exposed thermal pad area and all of the package terminals.

9. With these preparatory steps in place, the PowerPAD IC is simply placed in position and run through the solder reflow operation as any standard surface-mount component. This results in a part that is properly installed.

For detailed information on the PowerPAD package including thermal modeling considerations and repair procedures, please see Technical Brief SLMA002, *PowerPAD Thermally Enhanced Package*, located at www.ti.com.

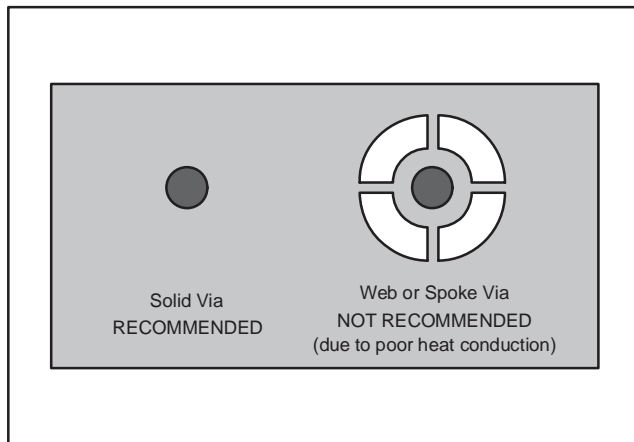

Figure 12. Internal ESD Protection

PACKAGING INFORMATION

ORDERABLE DEVICE	STATUS(1)	PACKAGE TYPE	PACKAGE DRAWING	PINS	PACKAGE QTY
OPA2357AIDGSR	ACTIVE	VSSOP	DGS	10	2500
OPA2357AIDGST	ACTIVE	VSSOP	DGS	10	250
OPA357AIDBVR	ACTIVE	SOP	DBV	6	3000
OPA357AIDBVT	ACTIVE	SOP	DBV	6	250
OPA357AIDDA	ACTIVE	HSOP	DDA	8	100
OPA357AIDAR	ACTIVE	HSOP	DDA	8	2500

(1) The marketing status values are defined as follows:

ACTIVE: Product device recommended for new designs.

LIFEBUY: TI has announced that the device will be discontinued, and a lifetime-buy period is in effect.

NRND: Not recommended for new designs. Device is in production to support existing customers, but TI does not recommend using this part in a new design.

PREVIEW: Device has been announced but is not in production. Samples may or may not be available.

OBSOLETE: TI has discontinued the production of the device.

DBV (R-PDSO-G6)

PLASTIC SMALL-OUTLINE PACKAGE

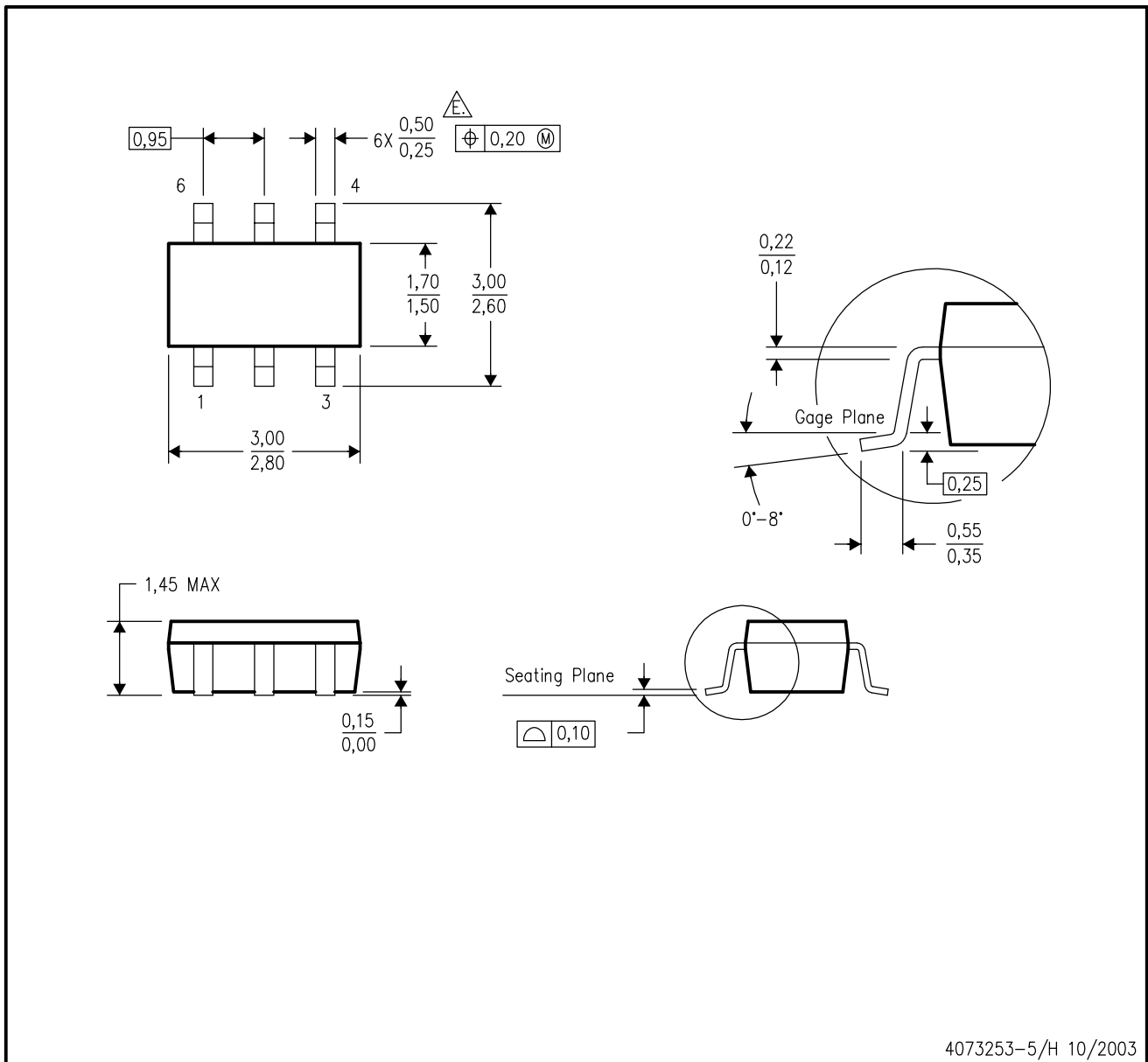

- NOTES:
- A. All linear dimensions are in millimeters.
 - B. This drawing is subject to change without notice.
 - C. Body dimensions do not include mold flash or protrusion.
 - D. Leads 1,2,3 may be wider than leads 4,5,6 for package orientation.
 - \triangle Falls within JEDEC MO-178 Variation AB, except minimum lead width.

DGS (S-PDSO-G10)

PLASTIC SMALL-OUTLINE PACKAGE

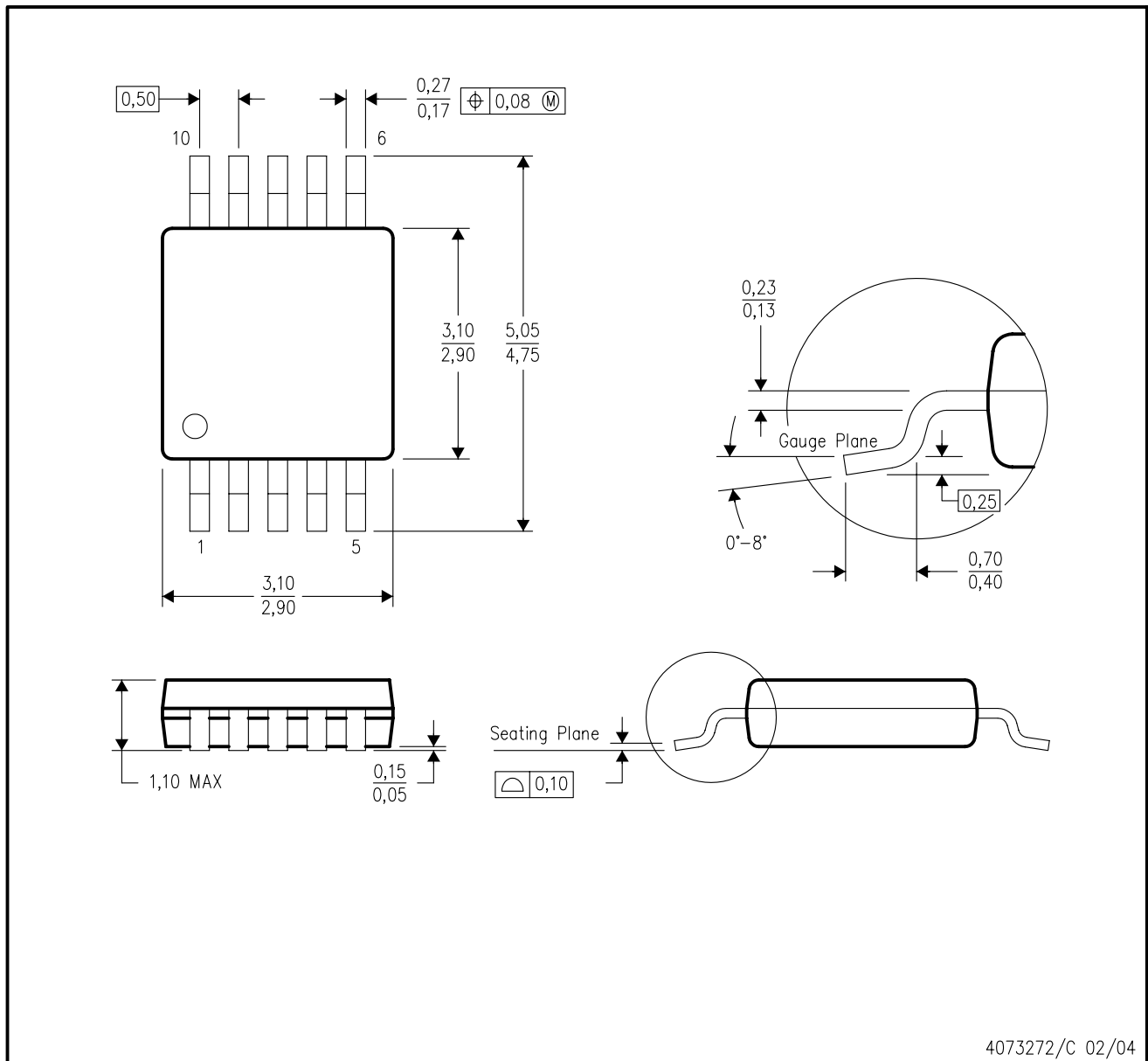

- NOTES:
- A. All linear dimensions are in millimeters.
 - B. This drawing is subject to change without notice.
 - C. Body dimensions do not include mold flash or protrusion.
 - D. Falls within JEDEC MO-187 variation BA.

DDA (R-PDSO-G8)

PowerPAD™ PLASTIC SMALL-OUTLINE PACKAGE

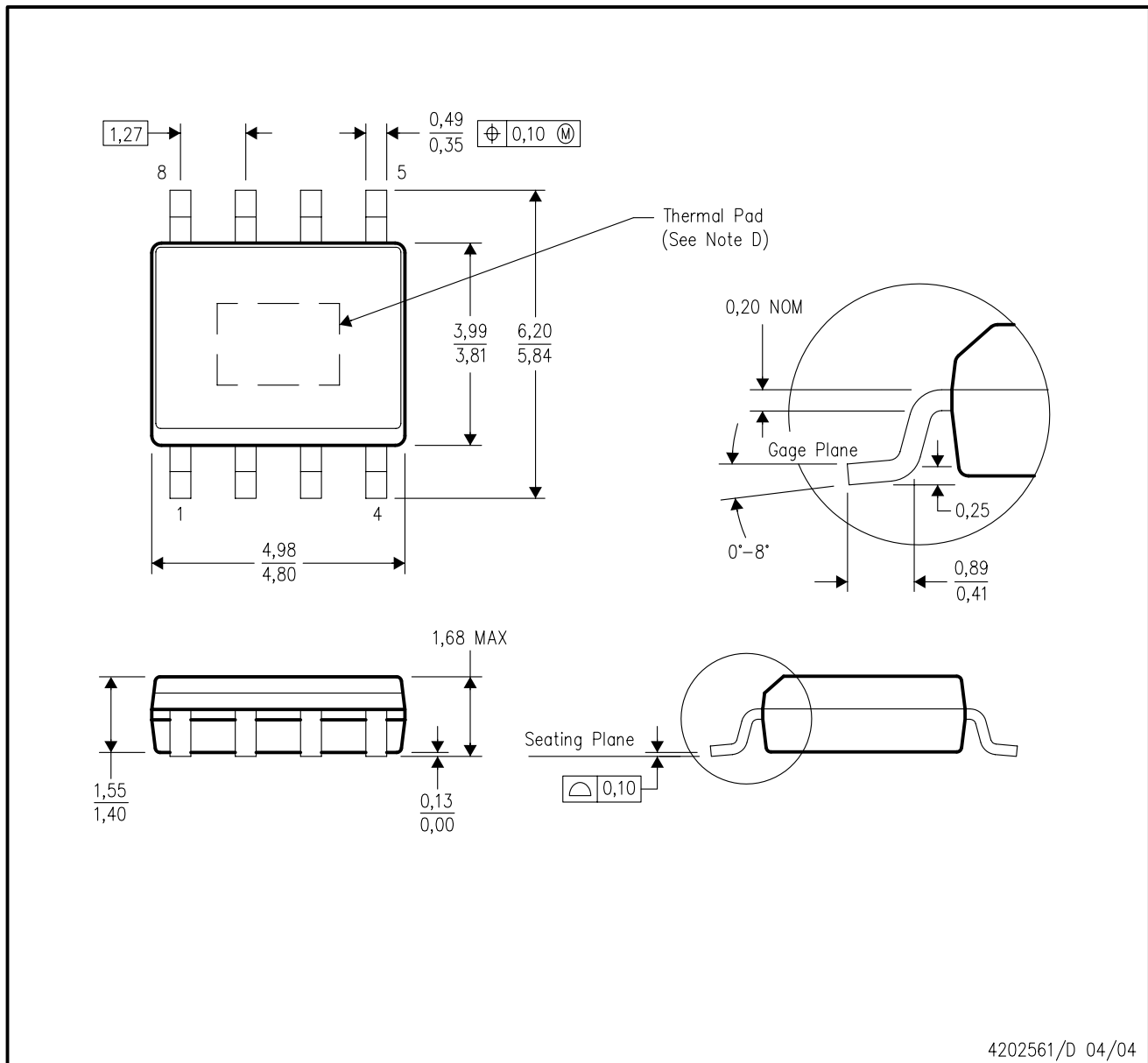

- NOTES:
- All linear dimensions are in millimeters.
 - This drawing is subject to change without notice.
 - Body dimensions do not include mold flash or protrusion not to exceed 0,15.
 - This package is designed to be soldered to a thermal pad on the board. Refer to Technical Brief, PowerPad Thermally Enhanced Package, Texas Instruments Literature No. SLMA002 for information regarding recommended board layout. This document is available at www.ti.com <<http://www.ti.com>>.

PowerPAD is a trademark of Texas Instruments.

IMPORTANT NOTICE

Texas Instruments Incorporated and its subsidiaries (TI) reserve the right to make corrections, modifications, enhancements, improvements, and other changes to its products and services at any time and to discontinue any product or service without notice. Customers should obtain the latest relevant information before placing orders and should verify that such information is current and complete. All products are sold subject to TI's terms and conditions of sale supplied at the time of order acknowledgment.

TI warrants performance of its hardware products to the specifications applicable at the time of sale in accordance with TI's standard warranty. Testing and other quality control techniques are used to the extent TI deems necessary to support this warranty. Except where mandated by government requirements, testing of all parameters of each product is not necessarily performed.

TI assumes no liability for applications assistance or customer product design. Customers are responsible for their products and applications using TI components. To minimize the risks associated with customer products and applications, customers should provide adequate design and operating safeguards.

TI does not warrant or represent that any license, either express or implied, is granted under any TI patent right, copyright, mask work right, or other TI intellectual property right relating to any combination, machine, or process in which TI products or services are used. Information published by TI regarding third-party products or services does not constitute a license from TI to use such products or services or a warranty or endorsement thereof. Use of such information may require a license from a third party under the patents or other intellectual property of the third party, or a license from TI under the patents or other intellectual property of TI.

Reproduction of information in TI data books or data sheets is permissible only if reproduction is without alteration and is accompanied by all associated warranties, conditions, limitations, and notices. Reproduction of this information with alteration is an unfair and deceptive business practice. TI is not responsible or liable for such altered documentation.

Resale of TI products or services with statements different from or beyond the parameters stated by TI for that product or service voids all express and any implied warranties for the associated TI product or service and is an unfair and deceptive business practice. TI is not responsible or liable for any such statements.

Following are URLs where you can obtain information on other Texas Instruments products and application solutions:

Products		Applications	
Amplifiers	amplifier.ti.com	Audio	www.ti.com/audio
Data Converters	dataconverter.ti.com	Automotive	www.ti.com/automotive
DSP	dsp.ti.com	Broadband	www.ti.com/broadband
Interface	interface.ti.com	Digital Control	www.ti.com/digitalcontrol
Logic	logic.ti.com	Military	www.ti.com/military
Power Mgmt	power.ti.com	Optical Networking	www.ti.com/opticalnetwork
Microcontrollers	microcontroller.ti.com	Security	www.ti.com/security
		Telephony	www.ti.com/telephony
		Video & Imaging	www.ti.com/video
		Wireless	www.ti.com/wireless

Mailing Address: Texas Instruments
Post Office Box 655303 Dallas, Texas 75265

Copyright © 2004, Texas Instruments Incorporated