

# MC74HCT4851A, MC74HCT4852A

## Analog Multiplexers/ Demultiplexers with Injection Current Effect Control with LSTTL Compatible Inputs

### Automotive Customized

This device is pin compatible to standard HC405x and MC1405xB analog mux/demux devices, but feature injection current effect control. This makes them especially suited for usage in automotive applications where voltages in excess of normal logic voltage are common.

The injection current effect control allows signals at disabled analog input channels to exceed the supply voltage range without affecting the signal of the enabled analog channel. This eliminates the need for external diode/ resistor networks typically used to keep the analog channel signals within the supply voltage range.

The devices utilize low power silicon gate CMOS technology. The Channel Select and Enable inputs are compatible with standard CMOS or LSTTL outputs.

#### Features

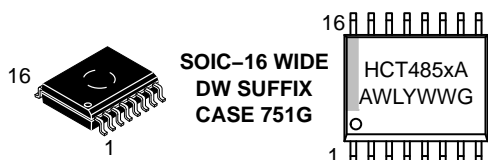
- Injection Current Cross-Coupling Less than 1mV/mA (See Figure 6)
- Pin Compatible to HC405x and MC1405xB Devices
- Power Supply Range ( $V_{CC} - GND$ ) = 4.5 to 5.5 V
- In Compliance With the Requirements of JEDEC Standard No. 7 A
- Chip Complexity: 154 FETs or 36 Equivalent Gates
- NLV Prefix for Automotive and Other Applications Requiring Unique Site and Control Change Requirements; AEC-Q100 Qualified and PPAP Capable
- These Devices are Pb-Free and are RoHS Compliant



ON Semiconductor®

[www.onsemi.com](http://www.onsemi.com)

#### MARKING DIAGRAMS



X = 1 or 2  
A = Assembly Location  
WL, L = Wafer Lot  
YY, Y = Year  
WW, W = Work Week  
G or ■ = Pb-Free Package

(Note: Microdot may be in either location)

#### ORDERING INFORMATION

See detailed ordering and shipping information in the package dimensions section on page 11 of this data sheet.

# MC74HCT4851A, MC74HCT4852A

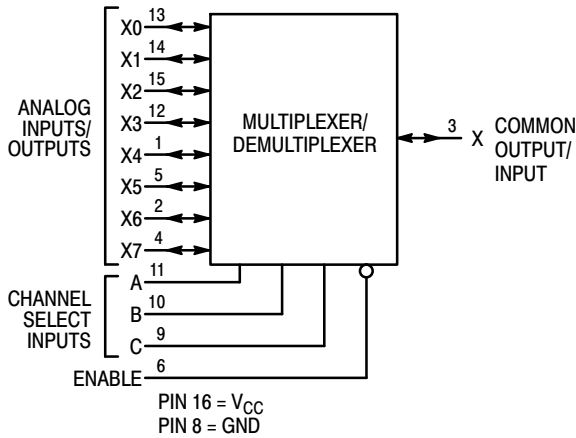


Figure 1. MC74HCT4851A Logic Diagram Single-Pole, 8-Position Plus Common Off

FUNCTION TABLE – MC74HCT4851A

Control Inputs				ON Channels
Enable	Select			
	C	B	A	
L	L	L	L	X0
L	L	L	H	X1
L	L	H	L	X2
L	L	H	H	X3
L	H	L	L	X4
L	H	L	H	X5
L	H	H	L	X6
L	H	H	H	X7
H	X	X	X	NONE

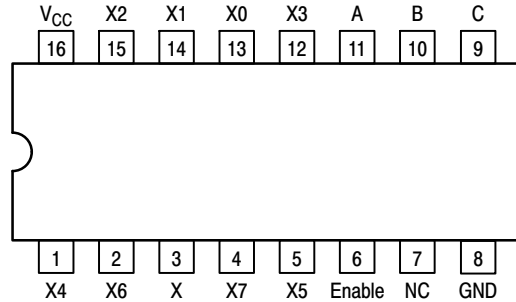


Figure 2. MC74HCT4851A 16-Lead Pinout (Top View)

FUNCTION TABLE – MC74HCT4852A

Control Inputs			ON Channels	
Enable	Select			
	B	A		
L	L	L	Y0	X0
L	L	H	Y1	X1
L	H	L	Y2	X2
L	H	H	Y3	X3
H	X	X	NONE	

X = Don't Care

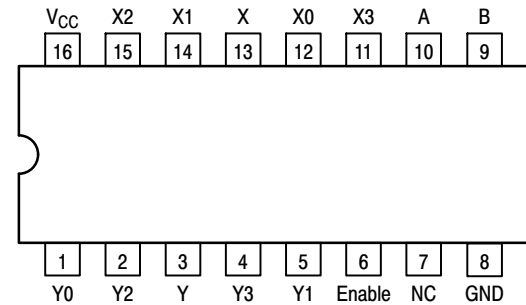


Figure 4. MC74HCT4852A 16-Lead Pinout (Top View)

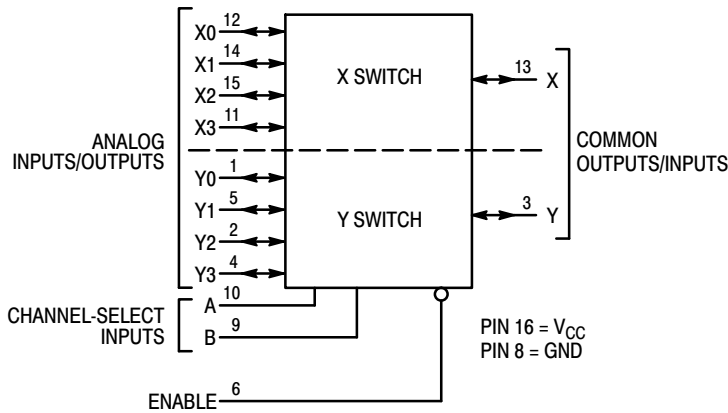


Figure 3. MC74HCT4852A Logic Diagram Double-Pole, 4-Position Plus Common Off

# MC74HCT4851A, MC74HCT4852A

## MAXIMUM RATINGS

Symbol	Parameter	Value	Unit
$V_{CC}$	Positive DC Supply Voltage (Referenced to GND)	-0.5 to + 7.0	V
$V_{in}$	DC Input Voltage (Any Pin) (Referenced to GND)	-0.5 to $V_{CC} + 0.5$	V
I	DC Current, Into or Out of Any Pin	$\pm 25$	mA
$P_D$	Power Dissipation in Still Air, SOIC Package† TSSOP Package†	500 450	mW
$T_{stg}$	Storage Temperature Range	-65 to + 150	°C
$T_L$	Lead Temperature, 1 mm from Case for 10 Seconds SOIC or TSSOP Package	260	°C

This device contains protection circuitry to guard against damage due to high static voltages or electric fields. However, precautions must be taken to avoid applications of any voltage higher than maximum rated voltages to this high-impedance circuit. For proper operation,  $V_{in}$  and  $V_{out}$  should be constrained to the range  $GND \leq (V_{in} \text{ or } V_{out}) \leq V_{CC}$ . Unused inputs must always be tied to an appropriate logic voltage level (e.g., either GND or  $V_{CC}$ ). Unused outputs must be left open.

Stresses exceeding those listed in the Maximum Ratings table may damage the device. If any of these limits are exceeded, device functionality should not be assumed, damage may occur and reliability may be affected.

## RECOMMENDED OPERATING CONDITIONS

Symbol	Parameter	Min	Max	Unit	
$V_{CC}$	Positive DC Supply Voltage (Referenced to GND)	4.5	5.5	V	
$V_{in}$	DC Input Voltage (Any Pin) (Referenced to GND)	GND	$V_{CC}$	V	
$V_{IO}^*$	Static or Dynamic Voltage Across Switch	0.0	1.2	V	
$T_A$	Operating Temperature Range, All Package Types	- 55	+ 125	°C	
$t_r, t_f$	Input Rise/Fall Time (Channel Select or Enable Inputs)	$V_{CC} = 2.0 \text{ V}$ $V_{CC} = 4.5 \text{ V}$ $V_{CC} = 6.0 \text{ V}$	0 0 0	1000 500 400	ns

Functional operation above the stresses listed in the Recommended Operating Ranges is not implied. Extended exposure to stresses beyond the Recommended Operating Ranges limits may affect device reliability.

\*For voltage drops across switch greater than 1.2 V (switch on), excessive  $V_{CC}$  current may be drawn; i.e., the current out of the switch may contain both  $V_{CC}$  and switch input components. The reliability of the device will be unaffected unless the Maximum Ratings are exceeded.

## DC CHARACTERISTICS — Digital Section (Voltages Referenced to GND) $V_{EE} = GND$ , Except Where Noted

Symbol	Parameter	Condition	$V_{CC}$ V	Guaranteed Limit			Unit
				-55 to 25°C	≤85°C	≤125°C	
$V_{IH}$	Minimum High-Level Input Voltage, Channel-Select or Enable Inputs	$R_{on} = \text{Per Spec}$	4.5 to 5.5	2.0	2.0	2.0	V
$V_{IL}$	Maximum Low-Level Input Voltage, Channel-Select or Enable Inputs	$R_{on} = \text{Per Spec}$	4.5 to 5.5	0.8	0.8	0.8	V
$I_{in}$	Maximum Input Leakage Current on Digital Pins (Enable/A/B/C)	$V_{in} = V_{CC}$ or GND	5.5	$\pm 0.1$	$\pm 1.0$	$\pm 1.0$	$\mu\text{A}$
$I_{CC}$	Maximum Quiescent Supply Current (per Package)	$V_{in(\text{digital})} = V_{CC}$ or GND $V_{in(\text{analog})} = GND$	5.5	2.0	20	40	$\mu\text{A}$

# MC74HCT4851A, MC74HCT4852A

## DC CHARACTERISTICS — Analog Section

Symbol	Parameter	Condition	V <sub>CC</sub>	Guaranteed Limit			Unit
				-55 to 25°C	≤85°C	≤125°C	
R <sub>on</sub>	Maximum "ON" Resistance	V <sub>in</sub> = V <sub>IL</sub> or V <sub>IH</sub> ; V <sub>IS</sub> = V <sub>CC</sub> to GND (Note 1); I <sub>S</sub> ≤ 2.0 mA (Note 2)	4.5 5.5	550 400	650 500	750 600	Ω
ΔR <sub>on</sub>	Delta "ON" Resistance	V <sub>in</sub> = V <sub>IL</sub> or V <sub>IH</sub> ; V <sub>IS</sub> = V <sub>CC</sub> /2 (Note 1); I <sub>S</sub> ≤ 2.0 mA (Note 2)	4.5 5.5	80 60	100 80	120 100	Ω
I <sub>off</sub>	Maximum Off-Channel Leakage Current, Any One Channel  Common Channel	V <sub>in</sub> = V <sub>CC</sub> or GND	5.5	±0.1 ±0.1	±0.1 ±0.1	±0.1 ±0.1	μA
I <sub>on</sub>	Maximum On-Channel Leakage Channel-to-Channel	V <sub>in</sub> = V <sub>CC</sub> or GND	5.5	±0.1	±0.1	±0.1	μA

1. V<sub>IS</sub> is the input voltage of an analog I/O pin.
2. I<sub>S</sub> is the current flowing in or out of analog I/O pin.

## AC CHARACTERISTICS (C<sub>L</sub> = 50 pF, Input t<sub>r</sub> = t<sub>f</sub> = 6 ns, V<sub>CC</sub> = 5.0 V ± 10%)

Symbol	Parameter	V <sub>CC</sub>	-55 to 25°C	≤85°C	≤125°C	Unit
t <sub>PHL</sub> , t <sub>PLH</sub>	Maximum Propagation Delay, Analog Input to Analog Output	5.0	40	45	50	ns
t <sub>PHL</sub> , t <sub>PHZ,PZH</sub> , t <sub>PLH</sub> , t <sub>PLZ,PZL</sub>	Maximum Propagation Delay, Enable or Channel-Select to Analog Output	5.0	80	90	100	ns
C <sub>in</sub>	Maximum Input Capacitance (All Switches Off) (All Switches Off)	Digital Pins Any Single Analog Pin Common Analog Pin	10 35 40	10 35 40	10 35 40	pF
C <sub>PD</sub>	Power Dissipation Capacitance	Typical	5.0	20		pF

## INJECTION CURRENT COUPLING SPECIFICATIONS (V<sub>CC</sub> = 5V, T<sub>A</sub> = -55°C to +125°C)

Symbol	Parameter	Condition	Typ	Max	Unit
V <sub>Δout</sub>	Maximum Shift of Output Voltage of Enabled Analog Channel	I <sub>in</sub> * ≤ 1 mA, R <sub>S</sub> ≤ 3.9 kΩ I <sub>in</sub> * ≤ 10 mA, R <sub>S</sub> ≤ 3.9 kΩ I <sub>in</sub> * ≤ 1 mA, R <sub>S</sub> ≤ 20 kΩ I <sub>in</sub> * ≤ 10 mA, R <sub>S</sub> ≤ 20 kΩ	0.1 1.0 0.5 5.0	1.0 5.0 2.0 20	mV

\* I<sub>in</sub> = Total current injected into all disabled channels.

# MC74HCT4851A, MC74HCT4852A

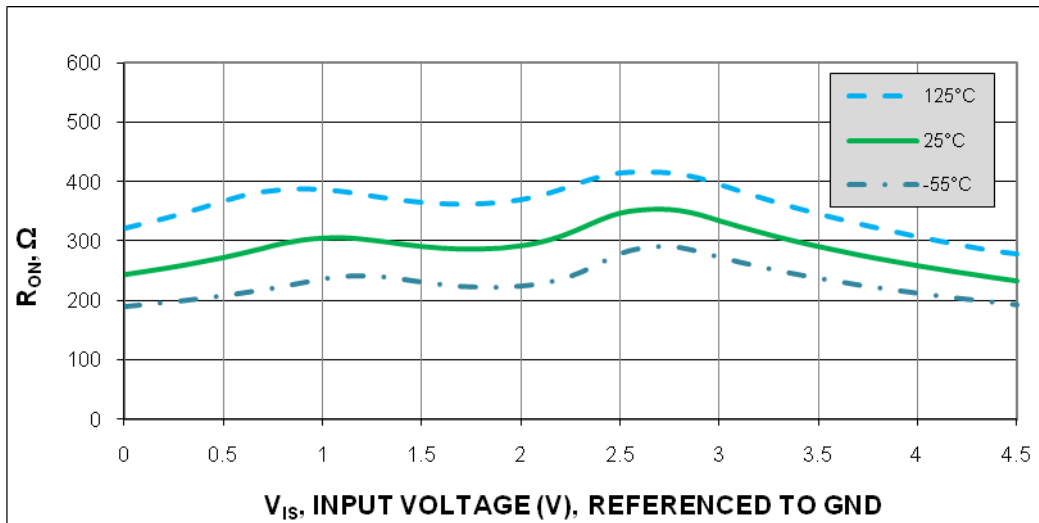


Figure 5. Typical On Resistance  $V_{CC} = 4.5V$

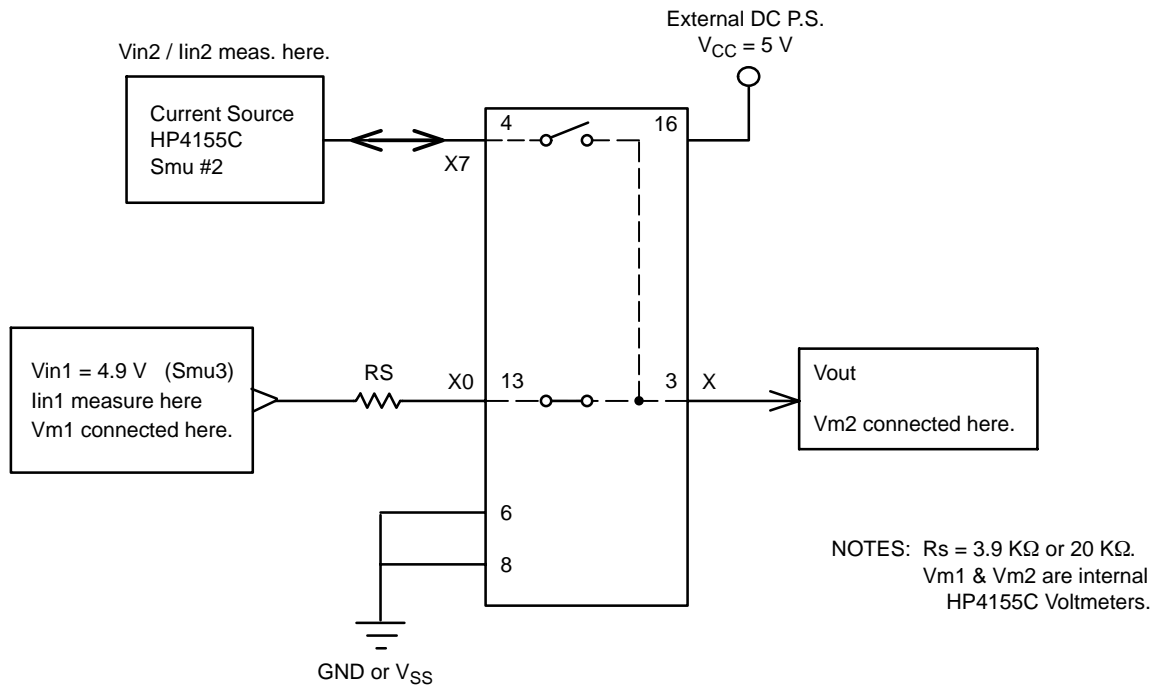
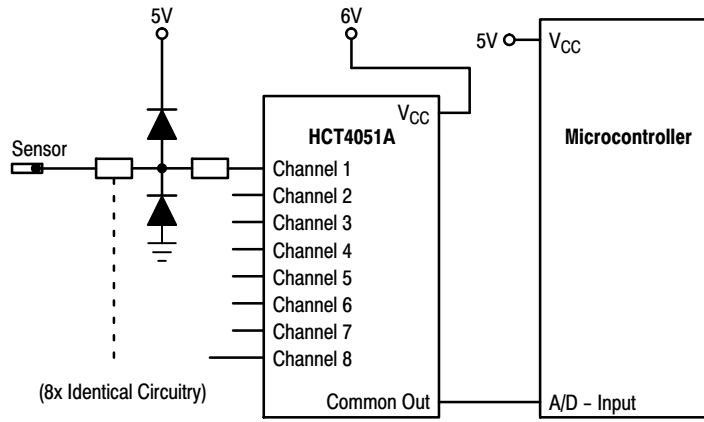


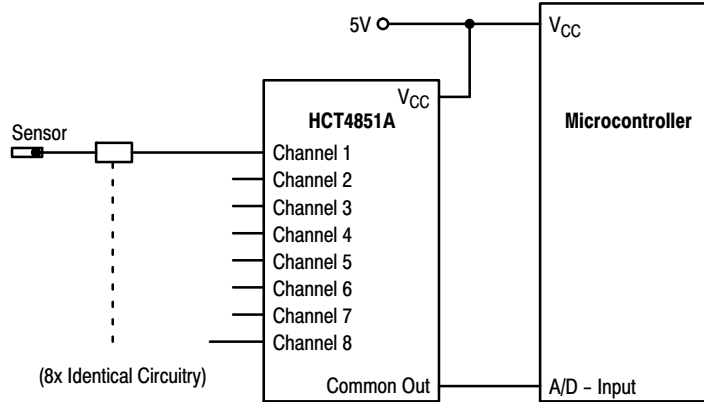
Figure 6. Injection Current Coupling Specification

# MC74HCT4851A, MC74HCT4852A



**Figure 7. Actual Technology**

Requires 32 passive components and one extra 6V regulator to suppress injection current into a standard HCT4051 multiplexer



**Figure 8. MC74HCT4851A Solution**

Solution by applying the HCT4851A multiplexer

# MC74HCT4851A, MC74HCT4852A

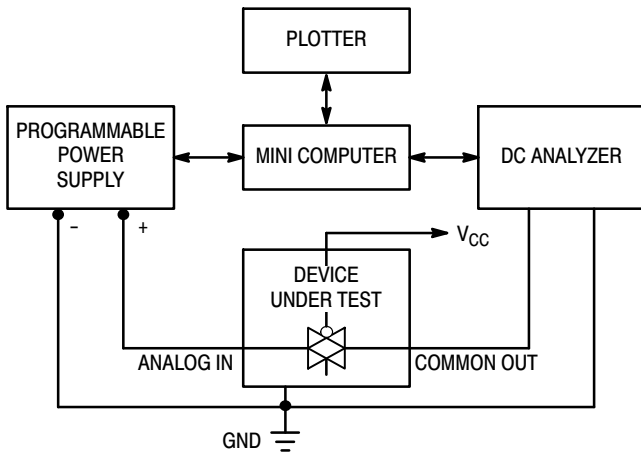


Figure 9. On Resistance Test Set-Up

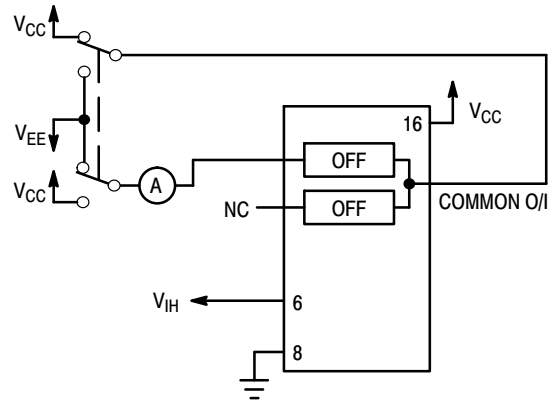


Figure 10. Maximum Off Channel Leakage Current, Any One Channel, Test Set-Up

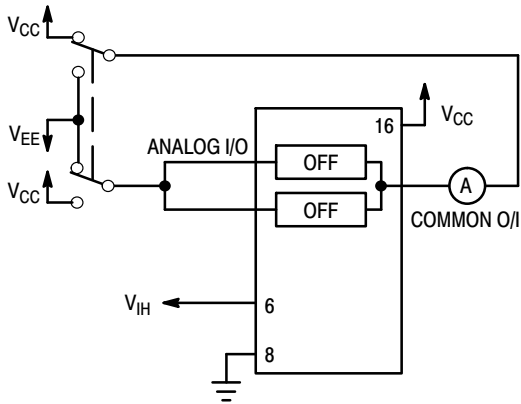


Figure 11. Maximum Off Channel Leakage Current, Common Channel, Test Set-Up

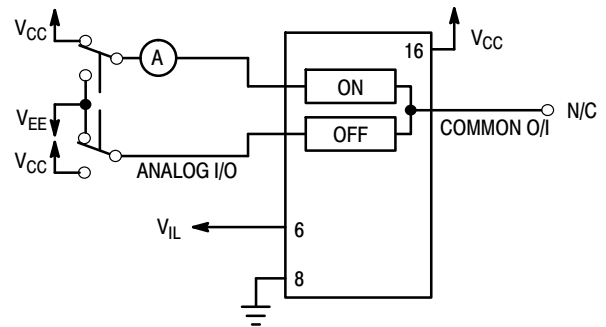


Figure 12. Maximum On Channel Leakage Current, Channel to Channel, Test Set-Up

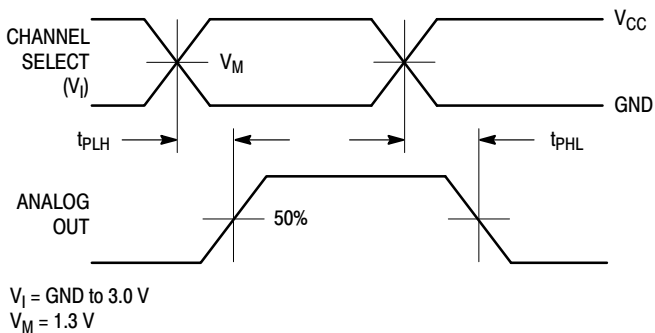
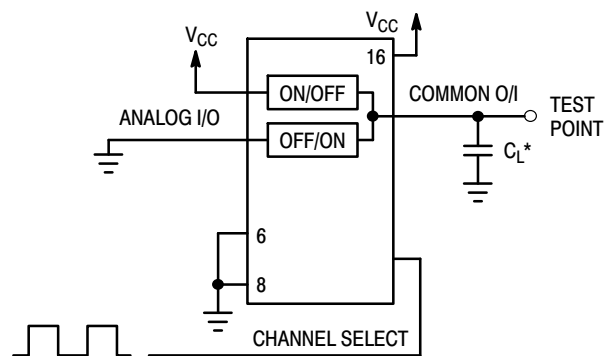


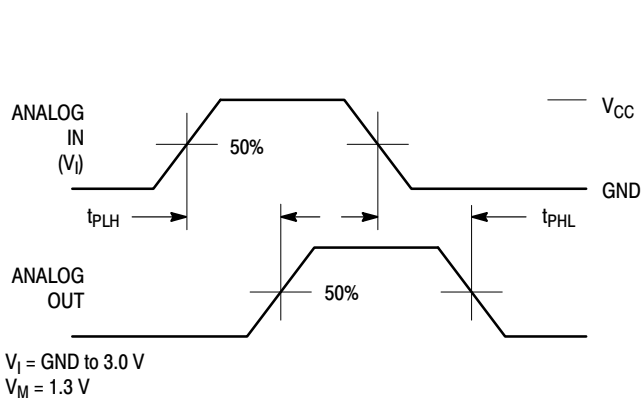
Figure 13. Propagation Delays, Channel Select to Analog Out



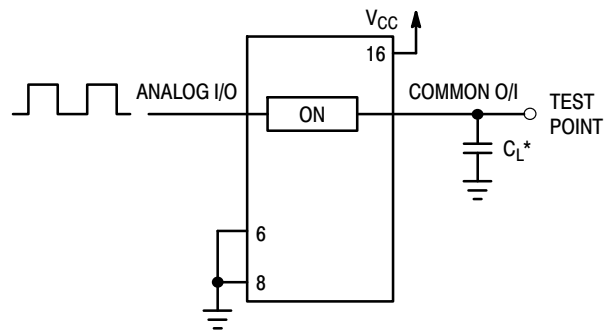
\*Includes all probe and jig capacitance

Figure 14. Propagation Delay, Test Set-Up Channel Select to Analog Out

# MC74HCT4851A, MC74HCT4852A

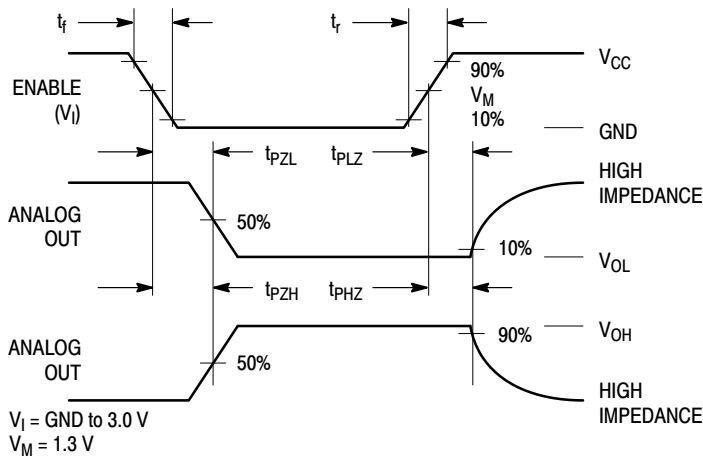


**Figure 15. Propagation Delays, Analog In to Analog Out**

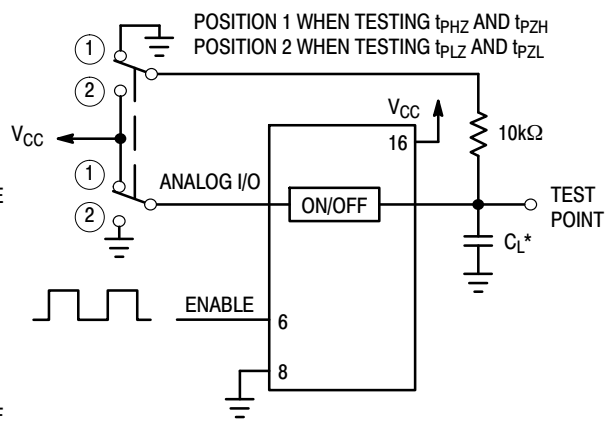


\*Includes all probe and jig capacitance

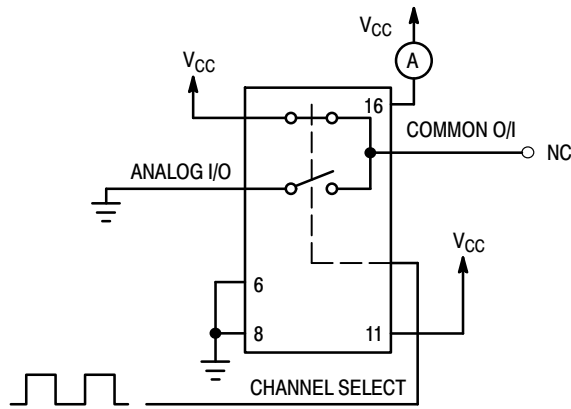
**Figure 16. Propagation Delay, Test Set-Up Analog In to Analog Out**



**Figure 17. Propagation Delays, Enable to Analog Out**



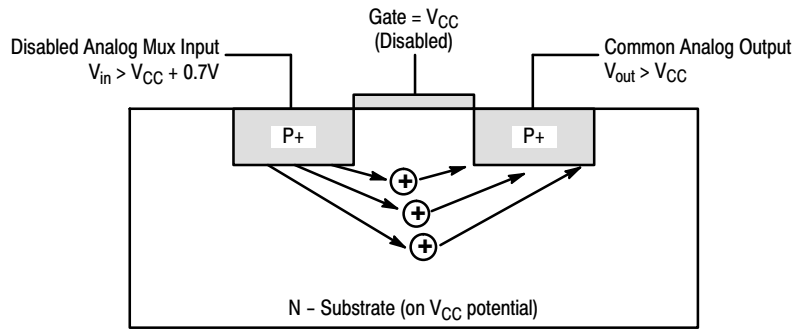
**Figure 18. Propagation Delay, Test Set-Up Enable to Analog Out**



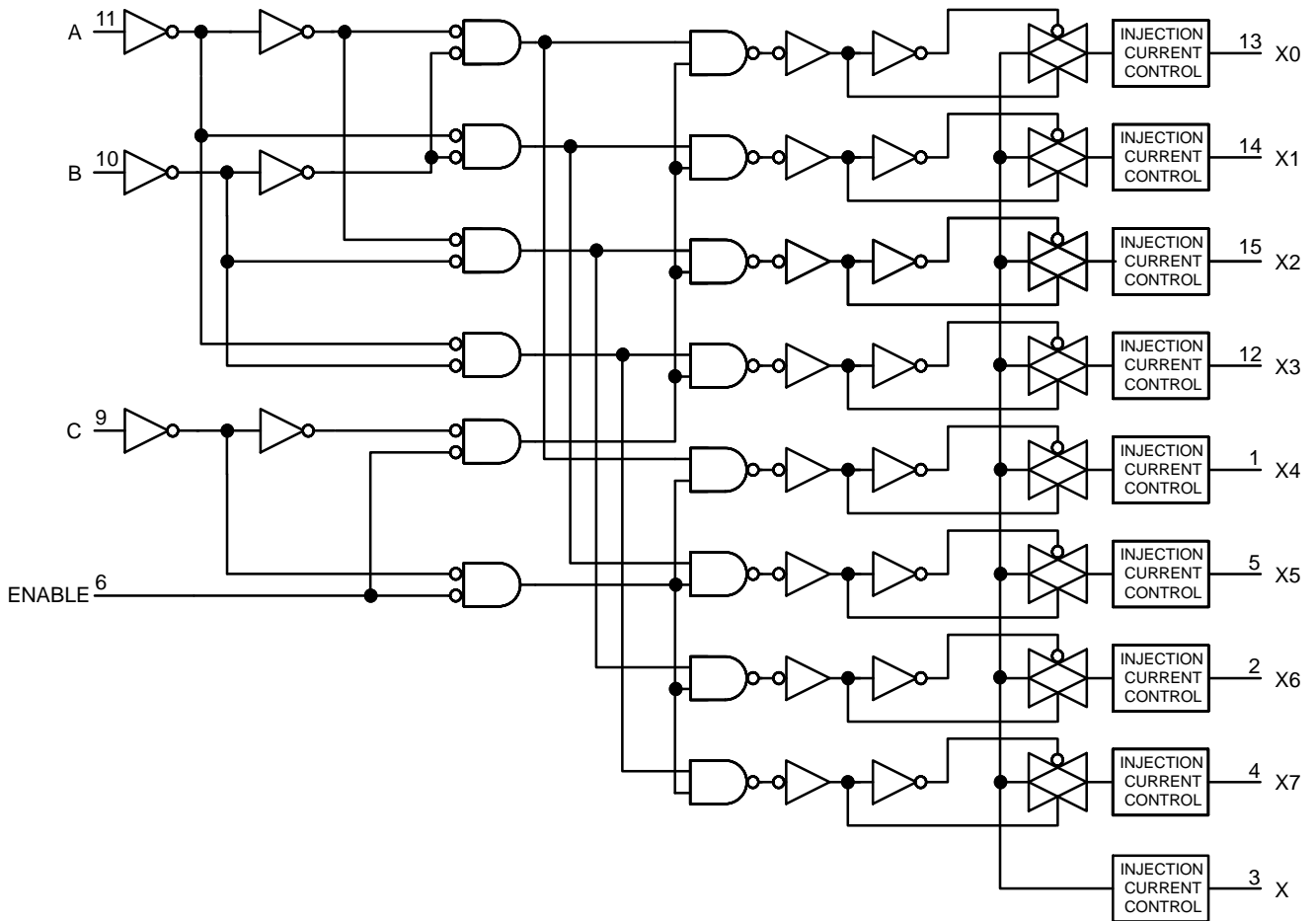
**Figure 19. Power Dissipation Capacitance, Test Set-Up**



# MC74HCT4851A, MC74HCT4852A



**Figure 20. Diagram of Bipolar Coupling Mechanism**  
Appears if V<sub>in</sub> exceeds V<sub>CC</sub>, driving injection current into the substrate



**Figure 21. Function Diagram, HCT4851A**

MC74HCT4851A, MC74HCT4852A

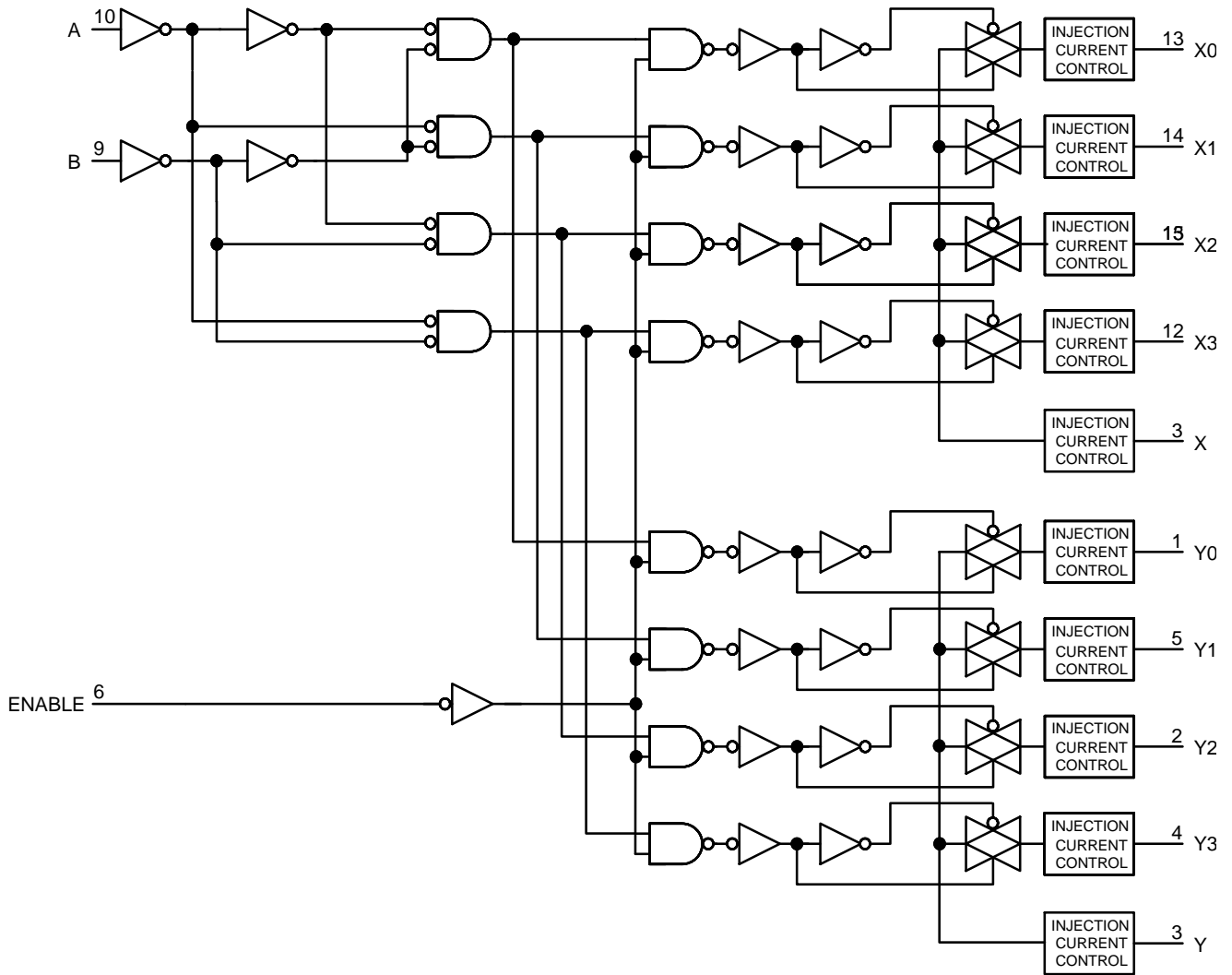


Figure 22. Function Diagram, HCT4852A

## MC74HCT4851A, MC74HCT4852A

### ORDERING INFORMATION

Device	Package	Shipping†
MC74HCT4851ADG	SOIC-16 (Pb-Free)	48 Units / Rail
MC74HCT4851ADR2G	SOIC-16 (Pb-Free)	2500 Units / Tape & Reel
NLV74HCT4851ADRG*	SOIC-16 (Pb-Free)	2500 Units / Tape & Reel
MC74HCT4851ADTG	TSSOP-16 (Pb-Free)	48 Units / Rail
M74HCT4851ADTR2G	TSSOP-16 (Pb-Free)	2500 Units / Tape & Reel
NLVHCT4851ADTR2G*	TSSOP-16 (Pb-Free)	2500 Units / Tape & Reel
M74HCT4851ADWR2G	SOIC-16 WIDE (Pb-Free)	1000 Units / Tape & Reel
MC74HCT4852ADG	SOIC-16 (Pb-Free)	48 Units / Rail
MC74HCT4852ADR2G	SOIC-16 (Pb-Free)	2500 Units / Tape & Reel
MC74HCT4852ADTG	TSSOP-16 (Pb-Free)	48 Units / Rail
M74HCT4852ADTR2G	TSSOP-16 (Pb-Free)	2500 Units / Tape & Reel
NLVHCT4852ADTR2G*	TSSOP-16 (Pb-Free)	2500 Units / Tape & Reel

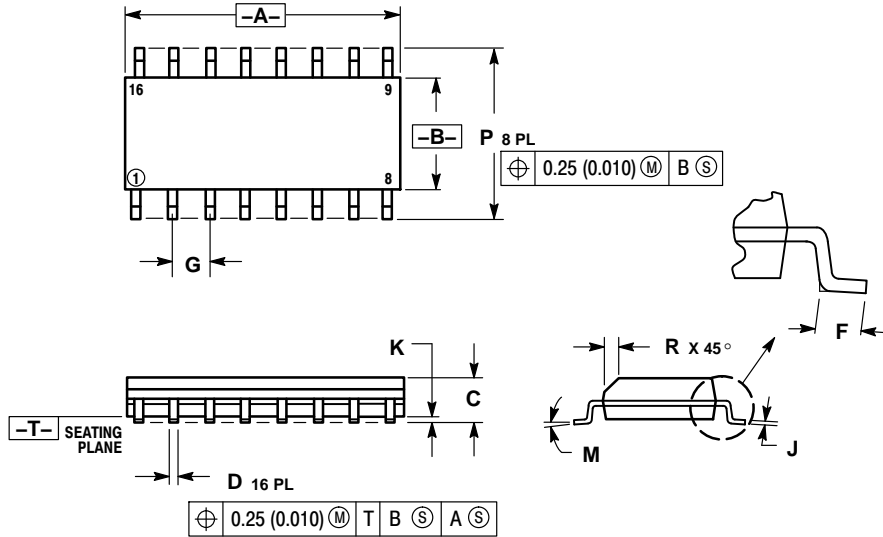
†For information on tape and reel specifications, including part orientation and tape sizes, please refer to our Tape and Reel Packaging Specifications Brochure, BRD8011/D.

\*NLV Prefix for Automotive and Other Applications Requiring Unique Site and Control Change Requirements; AEC-Q100 Qualified and PPAP Capable.

# MC74HCT4851A, MC74HCT4852A

## PACKAGE DIMENSIONS

SOIC-16  
D SUFFIX  
CASE 751B-05  
ISSUE K

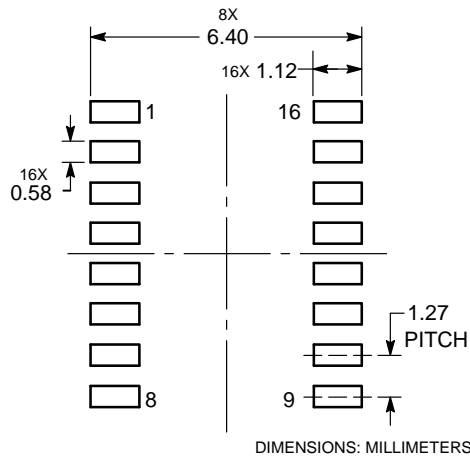


### NOTES:

1. DIMENSIONING AND TOLERANCING PER ANSI Y14.5M, 1982.
2. CONTROLLING DIMENSION: MILLIMETER.
3. DIMENSIONS A AND B DO NOT INCLUDE MOLD PROTRUSION.
4. MAXIMUM MOLD PROTRUSION 0.15 (0.006) PER SIDE.
5. DIMENSION D DOES NOT INCLUDE DAMBAR PROTRUSION. ALLOWABLE DAMBAR PROTRUSION SHALL BE 0.127 (0.005) TOTAL IN EXCESS OF THE D DIMENSION AT MAXIMUM MATERIAL CONDITION.

DIM	MILLIMETERS		INCHES	
	MIN	MAX	MIN	MAX
A	9.80	10.00	0.386	0.393
B	3.80	4.00	0.150	0.157
C	1.35	1.75	0.054	0.068
D	0.35	0.49	0.014	0.019
F	0.40	1.25	0.016	0.049
G	1.27 BSC		0.050 BSC	
J	0.19	0.25	0.008	0.009
K	0.10	0.25	0.004	0.009
M	0°	7°	0°	7°
P	5.80	6.20	0.229	0.244
R	0.25	0.50	0.010	0.019

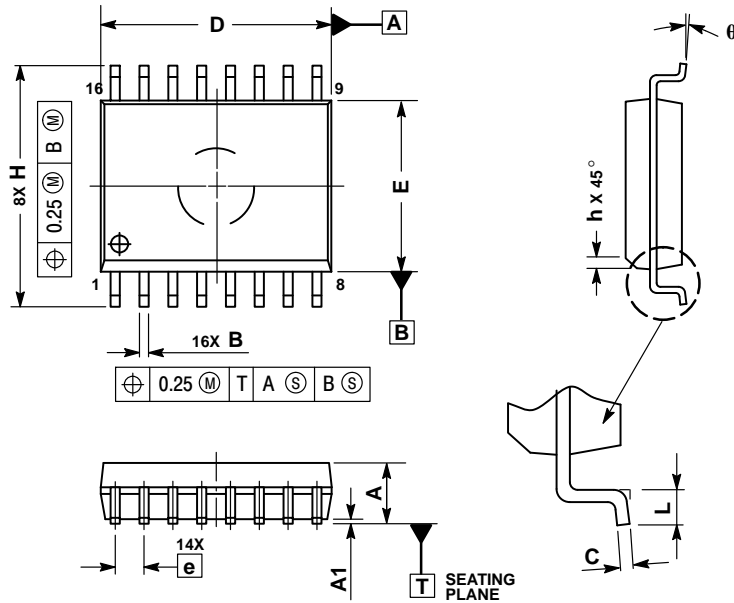
### SOLDERING FOOTPRINT



# MC74HCT4851A, MC74HCT4852A

## PACKAGE DIMENSIONS

SOIC-16 WB  
DW SUFFIX  
CASE 751G-03  
ISSUE D

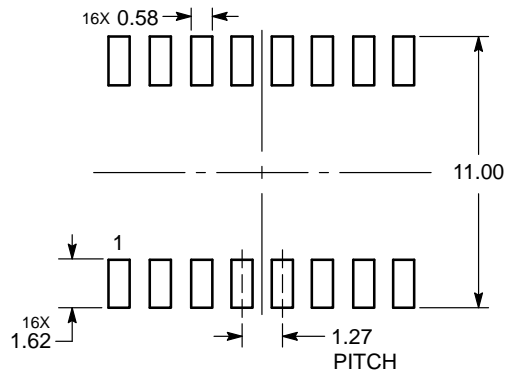


**NOTES:**

1. DIMENSIONS ARE IN MILLIMETERS.
2. INTERPRET DIMENSIONS AND TOLERANCES PER ASME Y14.5M, 1994.
3. DIMENSIONS D AND E DO NOT INCLUDE MOLD PROTRUSION.
4. MAXIMUM MOLD PROTRUSION 0.15 PER SIDE.
5. DIMENSION B DOES NOT INCLUDE DAMBAR PROTRUSION. ALLOWABLE DAMBAR PROTRUSION SHALL BE 0.13 TOTAL IN EXCESS OF THE B DIMENSION AT MAXIMUM MATERIAL CONDITION.

DIM	MILLIMETERS	
	MIN	MAX
A	2.35	2.65
A1	0.10	0.25
B	0.35	0.49
C	0.23	0.32
D	10.15	10.45
E	7.40	7.60
e	1.27 BSC	
H	10.05	10.55
h	0.25	0.75
L	0.50	0.90
q	0°	7°

### SOLDERING FOOTPRINT\*



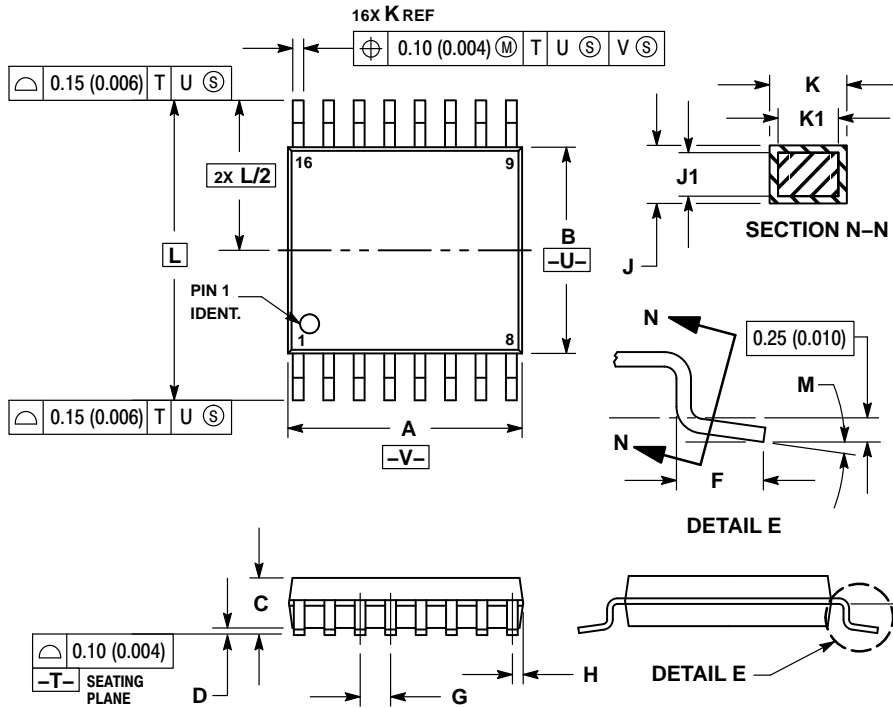
DIMENSIONS: MILLIMETERS

\*For additional information on our Pb-Free strategy and soldering details, please download the ON Semiconductor Soldering and Mounting Techniques Reference Manual, SOLDERRM/D.

# MC74HCT4851A, MC74HCT4852A

## PACKAGE DIMENSIONS

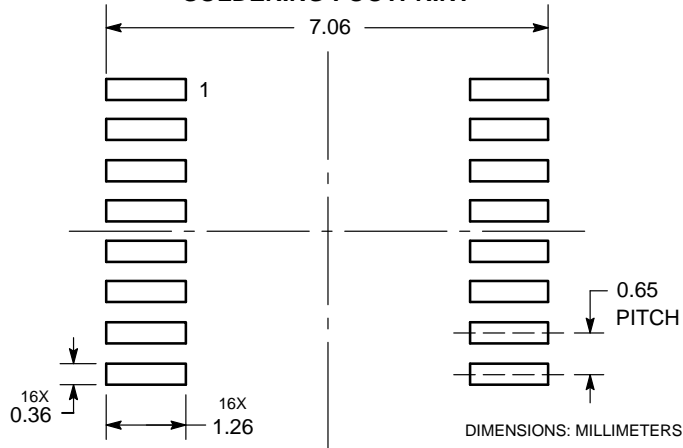
TSSOP-16  
CASE 948F  
ISSUE B



- NOTES:
1. DIMENSIONING AND TOLERANCING PER ANSI Y14.5M, 1982.
  2. CONTROLLING DIMENSION: MILLIMETER.
  3. DIMENSION A DOES NOT INCLUDE MOLD FLASH, PROTRUSIONS OR GATE BURRS. MOLD FLASH OR GATE BURRS SHALL NOT EXCEED 0.15 (0.006) PER SIDE.
  4. DIMENSION B DOES NOT INCLUDE INTERLEAD FLASH OR PROTRUSION. INTERLEAD FLASH OR PROTRUSION SHALL NOT EXCEED 0.25 (0.010) PER SIDE.
  5. DIMENSION K DOES NOT INCLUDE DAMBAR PROTRUSION. ALLOWABLE DAMBAR PROTRUSION SHALL BE 0.08 (0.003) TOTAL IN EXCESS OF THE K DIMENSION AT MAXIMUM MATERIAL CONDITION.
  6. TERMINAL NUMBERS ARE SHOWN FOR REFERENCE ONLY.
  7. DIMENSION A AND B ARE TO BE DETERMINED AT DATUM PLANE -W-.

DIM	MILLIMETERS		INCHES	
	MIN	MAX	MIN	MAX
A	4.90	5.10	0.193	0.200
B	4.30	4.50	0.169	0.177
C	---	1.20	---	0.047
D	0.05	0.15	0.002	0.006
F	0.50	0.75	0.020	0.030
G	0.65 BSC		0.026 BSC	
H	0.18	0.28	0.007	0.011
J	0.09	0.20	0.004	0.008
J1	0.09	0.16	0.004	0.006
K	0.19	0.30	0.007	0.012
K1	0.19	0.25	0.007	0.010
L	6.40 BSC		0.252 BSC	
M	0°	8°	0°	8°

### SOLDERING FOOTPRINT



ON Semiconductor and the are registered trademarks of Semiconductor Components Industries, LLC (SCILLC) or its subsidiaries in the United States and/or other countries. SCILLC owns the rights to a number of patents, trademarks, copyrights, trade secrets, and other intellectual property. A listing of SCILLC's product/patent coverage may be accessed at [www.onsemi.com/site/pdf/Patent-Marking.pdf](http://www.onsemi.com/site/pdf/Patent-Marking.pdf). SCILLC reserves the right to make changes without further notice to any products herein. SCILLC makes no warranty, representation or guarantee regarding the suitability of its products for any particular purpose, nor does SCILLC assume any liability arising out of the application or use of any product or circuit, and specifically disclaims any and all liability, including without limitation special, consequential or incidental damages. "Typical" parameters which may be provided in SCILLC data sheets and/or specifications can and do vary in different applications and actual performance may vary over time. All operating parameters, including "Typicals" must be validated for each customer application by customer's technical experts. SCILLC does not convey any license under its patent rights nor the rights of others. SCILLC products are not designed, intended, or authorized for use as components in systems intended for surgical implant into the body, or other applications intended to support or sustain life, or for any other application in which the failure of the SCILLC product could create a situation where personal injury or death may occur. Should Buyer purchase or use SCILLC products for any such unintended or unauthorized application, Buyer shall indemnify and hold SCILLC and its officers, employees, subsidiaries, affiliates, and distributors harmless against all claims, costs, damages, and expenses, and reasonable attorney fees arising out of, directly or indirectly, any claim of personal injury or death associated with such unintended or unauthorized use, even if such claim alleges that SCILLC was negligent regarding the design or manufacture of the part. SCILLC is an Equal Opportunity/Affirmative Action Employer. This literature is subject to all applicable copyright laws and is not for resale in any manner.

### PUBLICATION ORDERING INFORMATION

#### LITERATURE FULFILLMENT:

Literature Distribution Center for ON Semiconductor  
P.O. Box 5163, Denver, Colorado 80217 USA  
Phone: 303-675-2175 or 800-344-3860 Toll Free USA/Canada  
Fax: 303-675-2176 or 800-344-3867 Toll Free USA/Canada  
Email: [orderlit@onsemi.com](mailto:orderlit@onsemi.com)

N. American Technical Support: 800-282-9855 Toll Free  
USA/Canada  
Europe, Middle East and Africa Technical Support:  
Phone: 421 33 790 2910  
Japan Customer Focus Center  
Phone: 81-3-5817-1050

ON Semiconductor Website: [www.onsemi.com](http://www.onsemi.com)

Order Literature: <http://www.onsemi.com/orderlit>

For additional information, please contact your local Sales Representative