

General-purpose dual bipolar timers

Features

- Low turn-off time
- Maximum operating frequency greater than 500 kHz
- Timing from microseconds to hours
- Operates in both astable and monostable modes
- Output can source or sink up to 200 mA
- Adjustable duty cycle
- TTL compatible
- Temperature stability of 0.005% per °C

Description

The NE556, SA556 and SE556 dual monolithic timing circuits are highly stable controllers capable of producing accurate time delays or oscillation. In the time delay mode of operation, the time is precisely controlled by one external resistor and capacitor. For a stable operation as an oscillator, the free running frequency and the duty cycle are both accurately controlled with two external resistors and one capacitor.

The circuits may be triggered and reset on falling waveforms, and the output structure can source or sink up to 200 mA.

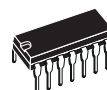

N
DIP14
(Plastic package)



D
SO14
(Plastic micropackage)

Pin connections (top view)

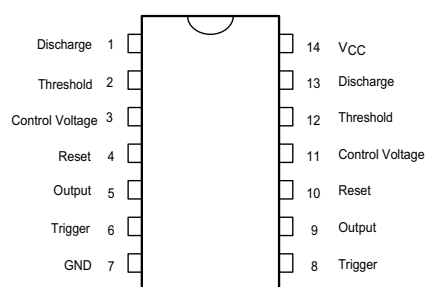

1 Schematic diagrams

Figure 1. Block diagram

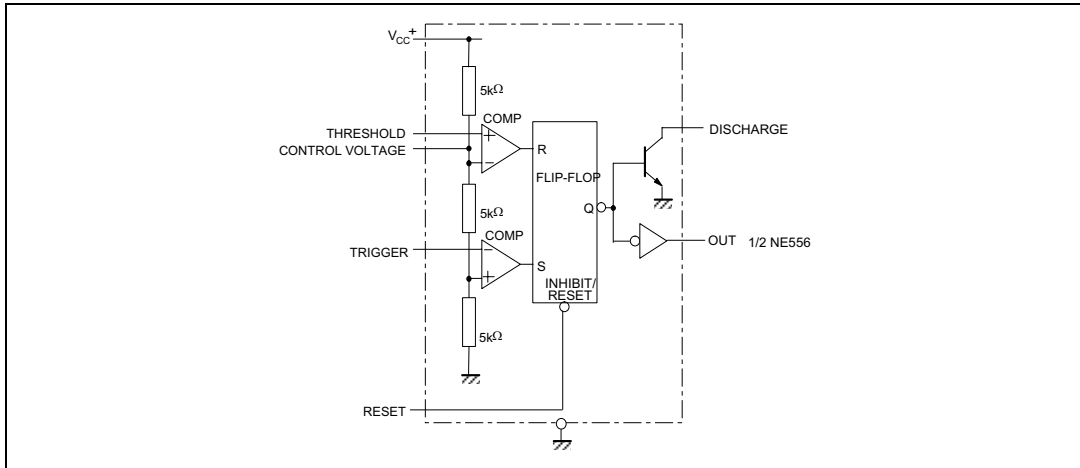
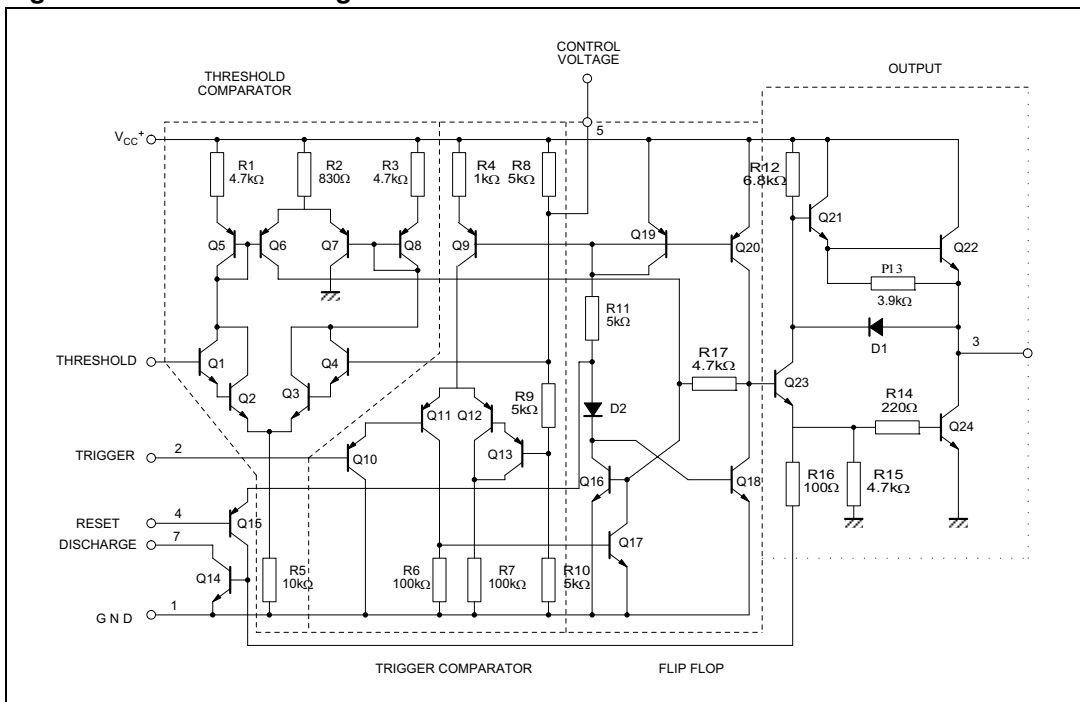

Figure 2. Schematic diagram



2 Absolute maximum ratings and operating conditions

Table 1. Absolute maximum ratings

Symbol	Parameter	Value	Unit
V_{CC}	Supply voltage	18	V
I_{OUT}	Output current (sink and source)	± 225	mA
R_{thja}	Thermal resistance junction to ambient ⁽¹⁾		$^{\circ}\text{C}/\text{W}$
	DIP14 SO-14	80 105	
R_{thjc}	Thermal resistance junction to case ⁽¹⁾		$^{\circ}\text{C}/\text{W}$
	DIP14 SO-14	33 31	
ESD	Human body model (HBM) ⁽²⁾	1000	V
	Machine model (MM) ⁽³⁾	150	
	Charged device model (CDM) ⁽⁴⁾	1500	
	Latch-up immunity	200	mA
T_{LEAD}	Lead temperature (soldering 10 seconds)	260	$^{\circ}\text{C}$
T_j	Junction temperature	150	$^{\circ}\text{C}$
T_{stg}	Storage temperature range	-65 to 150	$^{\circ}\text{C}$

- Short-circuits can cause excessive heating. These values are typical and valid only for a single layer PCB.
- Human body model: a 100 pF capacitor is charged to the specified voltage, then discharged through a 1.5k Ω resistor between two pins of the device. This is done for all couples of connected pin combinations while the other pins are floating.
- Machine model: a 200 pF capacitor is charged to the specified voltage, then discharged directly between two pins of the device with no external series resistor (internal resistor < 5 Ω). This is done for all couples of connected pin combinations while the other pins are floating.
- Charged device model: all pins and the package are charged together to the specified voltage and then discharged directly to the ground through only one pin. This is done for all pins.

Table 2. Operating conditions

Symbol	Parameter	Value	Unit
V_{CC}	Supply voltage		V
	NE556	4.5 to 16	
	SA556 SE556	4.5 to 16 4.5 to 18	
V_{th} , V_{trig} , V_{cl} , V_{reset}	Maximum input voltage	V_{CC}	V
I_{OUT}	Output current (sink and source)	± 200	mA
T_{oper}	Operating free air temperature range		$^{\circ}\text{C}$
	NE556	0 to 70	
	SA556 SE556	-40 to 105 -55 to 125	

3 Electrical characteristics

Table 3. $T_{amb} = +25^{\circ}C$, $V_{CC} = +5V$ to $+15V$ (unless otherwise specified)

Symbol	Parameter	SE556			NE556 - SA556			Unit
		Min.	Typ.	Max.	Min.	Typ.	Max.	
I_{CC}	Supply current ($R_L \rightarrow \infty$) (2 timers)							mA
	Low state $V_{CC} = +5V$		6	10		6	12	
	$V_{CC} = +15V$		20	24		20	30	
	High State $V_{CC} = +5V$		4			4		
	Timing error (monostable) ($R_A = 2k\Omega$ to $100k\Omega$, $C = 0.1\mu F$)							% ppm/ $^{\circ}C$ %/V
	Initial accuracy ⁽¹⁾		0.5	2		1	3	
	Drift with temperature		30	100		50		
	Drift with supply voltage		0.05	0.2		0.1	0.5	
	Timing error (astable) ($R_A, R_B = 1k\Omega$ to $100k\Omega$, $C = 0.1\mu F$, $V_{CC} = +15V$)							% ppm/ $^{\circ}C$ %/V
	Initial accuracy ⁽¹⁾		1.5			2.25		
	Drift with temperature		90			150		
	Drift with supply voltage		0.15			0.3		
V_{CL}	Control voltage level							V
	$V_{CC} = +15V$	9.6	10	10.4	9	10	11	
	$V_{CC} = +5V$	2.9	3.33	3.8	2.6	3.33	4	
V_{th}	Threshold voltage							V
	$V_{CC} = +15V$	9.4	10	10.6	8.8	10	11.2	
	$V_{CC} = +5V$	2.7	3.33	4	2.4	3.33	4.2	
I_{th}	Threshold current ⁽²⁾		0.1	0.25		0.1	0.25	μA
V_{trig}	Trigger voltage							V
	$V_{CC} = +15V$	4.8	5	5.2	4.5	5	5.6	
	$V_{CC} = +5V$	1.45	1.67	1.9	1.1	1.67	2.2	
I_{trig}	Trigger current ($V_{trig} = 0V$)		0.5	0.9		0.5	2.0	μA
V_{reset}	Reset voltage ⁽³⁾	0.4	0.7	1	0.4	0.7	1	V
I_{reset}	Reset current							mA
	$V_{reset} = +0.4V$		0.1	0.4		0.1	0.4	
	$V_{reset} = 0V$		0.4	1		0.4	1.5	
V_{OL}	Low level output voltage							V
	$V_{CC} = +15V$		0.1	0.15		0.1	0.25	
	$I_{O(sink)} = 10mA$		0.4	0.5		0.4	0.75	
	$I_{O(sink)} = 50mA$		2	2.2		2	2.5	
	$I_{O(sink)} = 100mA$		2.5			2.5		
	$I_{O(sink)} = 200mA$		0.1	0.25		0.3	0.4	
$V_{CC} = +5V$		0.05	0.2		0.25	0.35		
V_{OH}	High level output voltage							V
	$V_{CC} = +15V$	13	12.5			12.5		
	$I_{O(sink)} = 200mA$		13.3			13.3		
	$I_{O(sink)} = 100mA$		3	3.3		3.3		
	$V_{CC} = +5V$				12.75		12.75	
	$I_{O(sink)} = 100mA$				2.75		3.3	

Table 3. $T_{amb} = +25^{\circ}C$, $V_{CC} = +5V$ to $+15V$ (unless otherwise specified) (continued)

Symbol	Parameter	SE556			NE556 - SA556			Unit
		Min.	Typ.	Max.	Min.	Typ.	Max.	
$I_{dis(off)}$	Discharge pin leakage current (output high) ($V_{dis} = 10V$)		20	100		20	100	nA
$V_{dis(sat)}$	Discharge pin saturation voltage (output low) ⁽⁴⁾ $V_{CC} = +15V, I_{dis} = 15mA$ $V_{CC} = +5V, I_{dis} = 4.5mA$		180	480		180	480	mV
			80	200		80	200	
t_r t_f	Output rise time		100	200		100	300	ns
	Output fall time		100	200		100	300	
t_{off}	Turn-off time ⁽⁵⁾ ($V_{reset} = V_{CC}$)		0.5			0.5		μs

1. Tested at $V_{CC} = +5V$ and $V_{CC} = +15V$
2. This will determine the maximum value of $R_A + R_B$ for +15V operation the max total is $R = 20 M\Omega$ and for +5 V operation the max total $R = 3.5 M\Omega$
3. Specified with trigger input high
4. No protection against excessive pin 7 current is necessary, providing the package dissipation rating will not be exceeded
5. Time measured from a positive going input pulse from 0 to $0.8 \times V_{CC}$ into the threshold to the drop from high to low of the output trigger is tied to threshold.

Figure 3. Minimum pulse width required for triggering

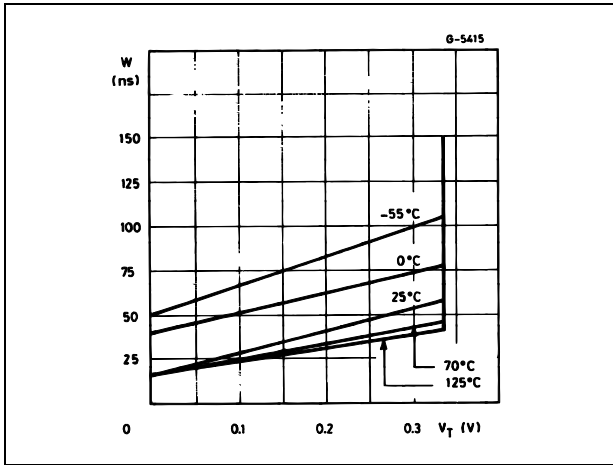

Figure 4. Supply current versus supply voltage

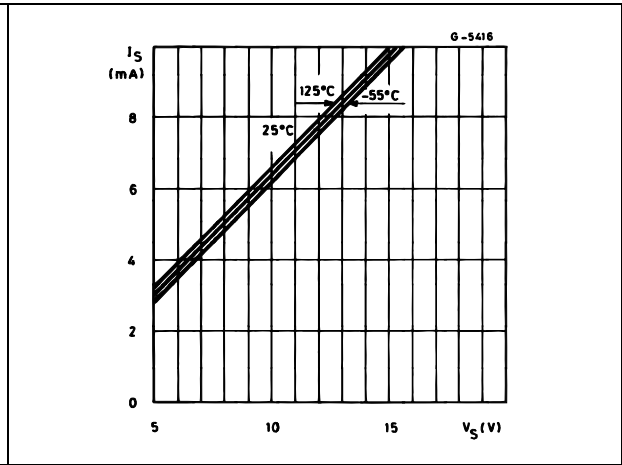

Figure 5. Delay time versus temperature

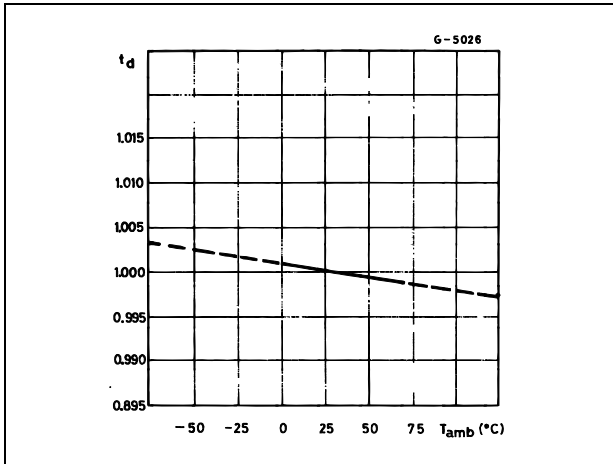

Figure 6. Low output voltage versus output sink current

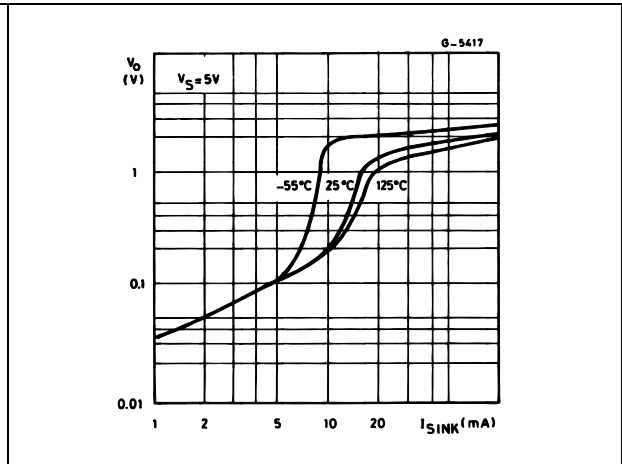

Figure 7. Low output voltage versus output sink current

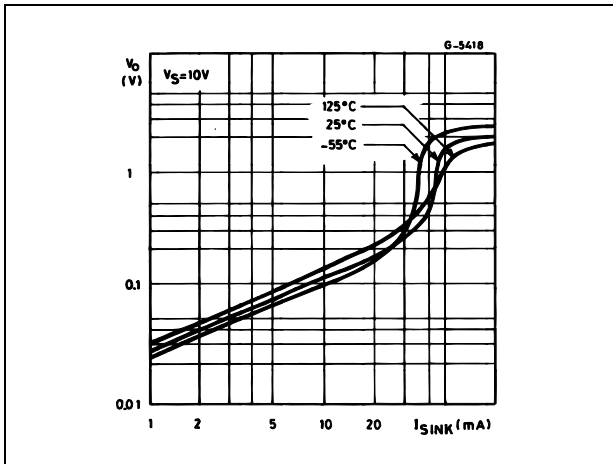

Figure 8. Low output voltage versus output sink current

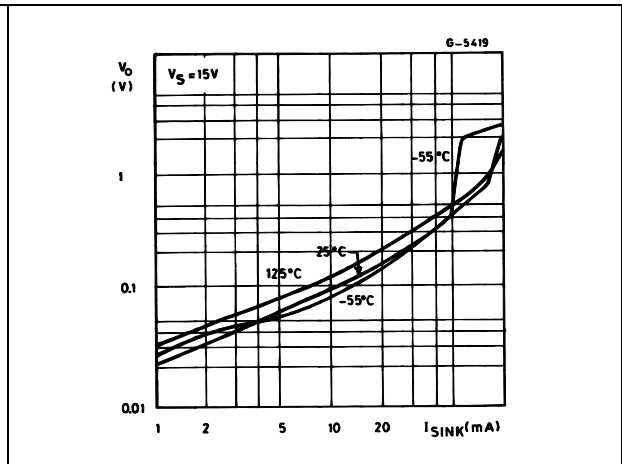

Figure 9. High output voltage drop versus output

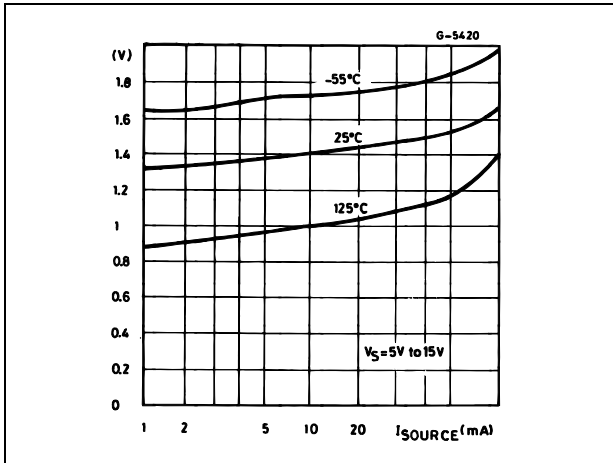

Figure 10. Delay time versus supply voltage

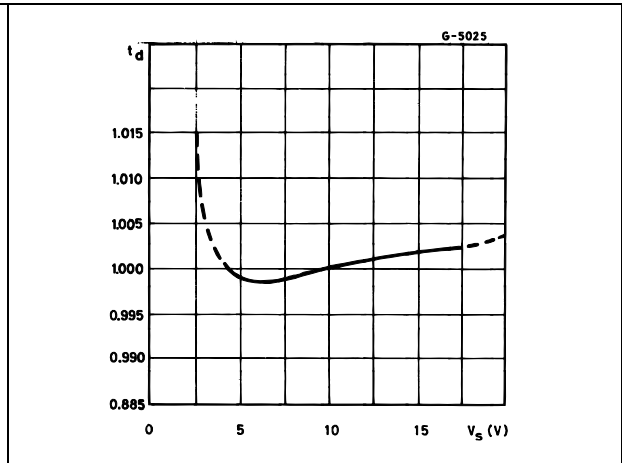
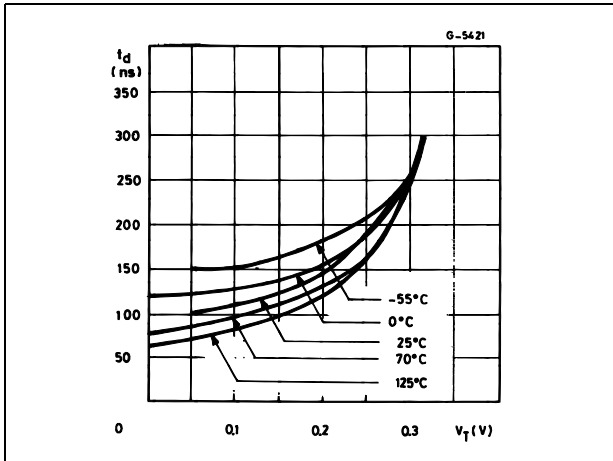

Figure 11. Propagation delay versus voltage level of trigger value



4 Application information

4.1 Typical application

Figure 12. 50% duty cycle oscillator

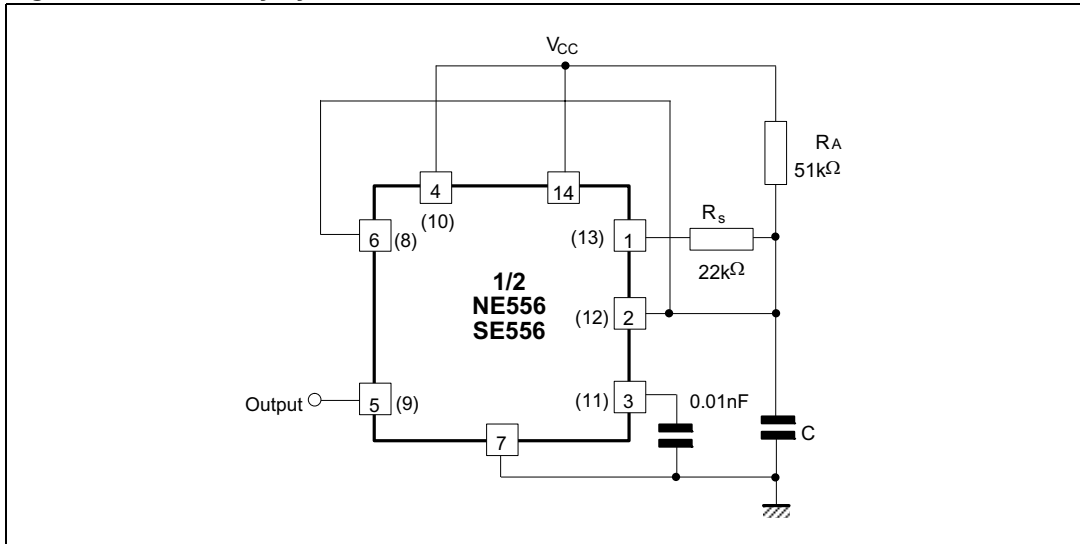

$$t_1 = 0.693 R_A \cdot C$$

$$t_2 = \left[\frac{R_A R_B}{R_A + R_B} \right] C \ln \left[\frac{R_B - 2R_A}{2R_B - R_A} \right]$$

$$f = \frac{t_1}{t_1 + t_2} \quad R_B < \frac{1}{2} R_A \quad t_i$$

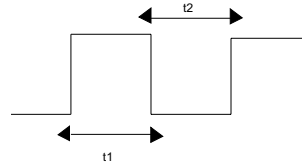

Figure 13. Pulse width modulator

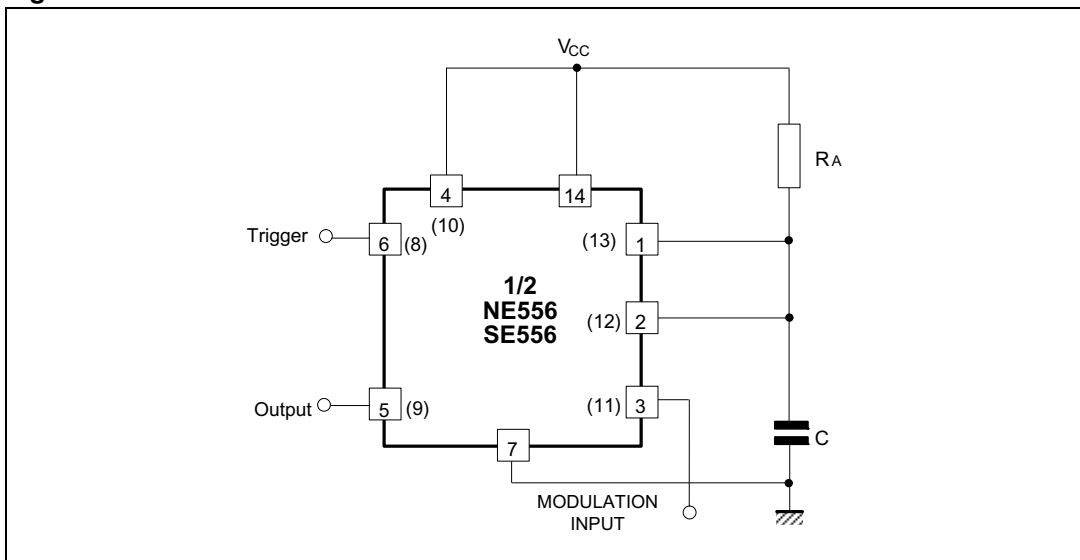
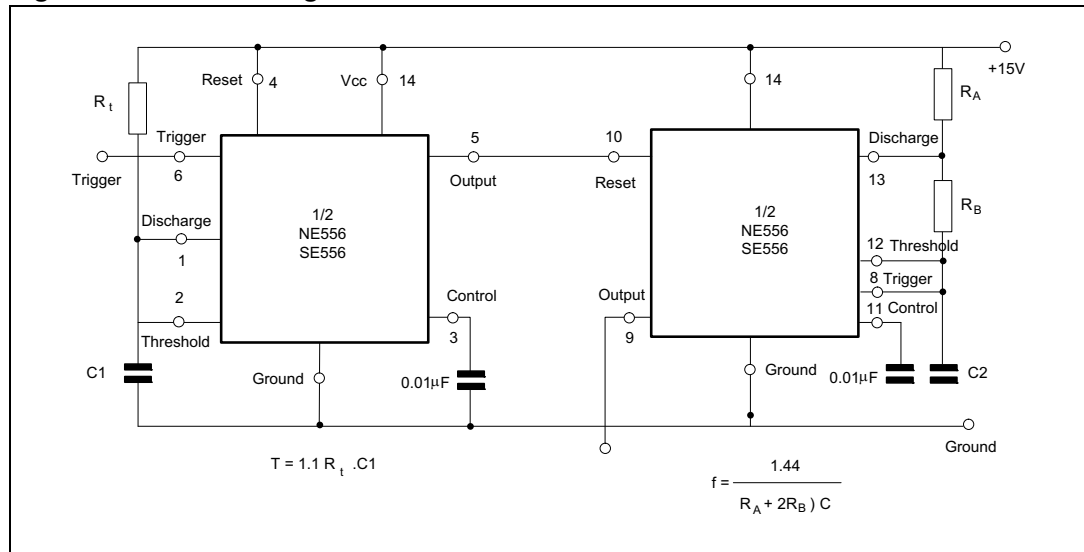

Figure 14. Tone burst generator



For a tone burst generator the first timer is used as a monostable and determines the tone duration when triggered by a positive pulse at pin 6. The second timer is enabled by the high output or the monostable. It is connected as an astable and determines the frequency of the tone.

Figure 15. Monostable operation

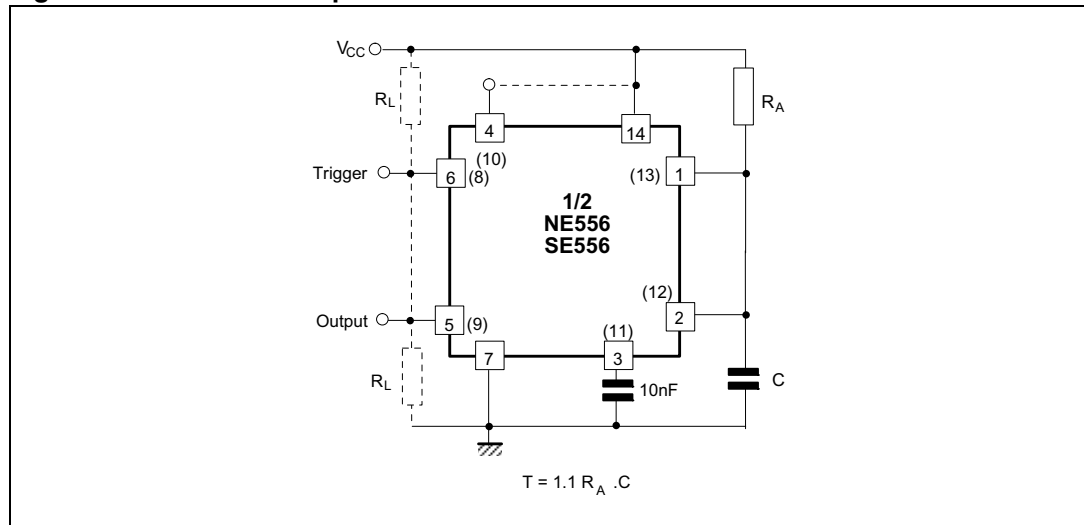
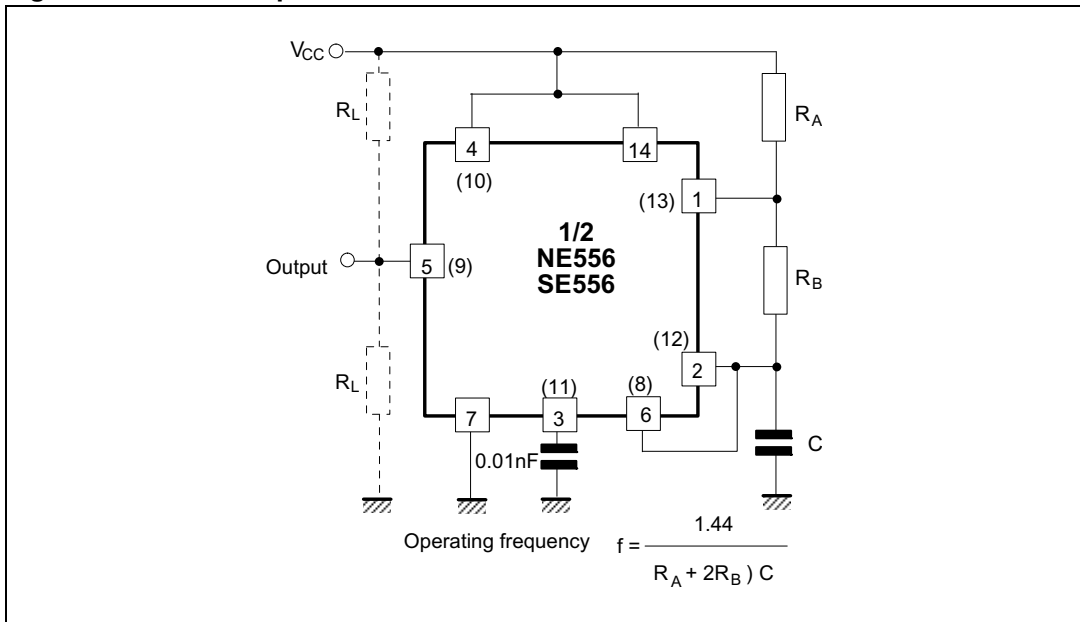
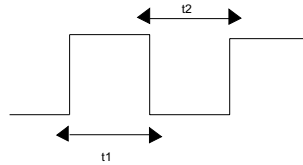

Figure 16. Astable operation



$t_1 = 0.693 (R_A + R_B) C$ output high

$t_2 = 0.693 R_B C$ output low



5 Package information

In order to meet environmental requirements, ST offers these devices in different grades of ECOPACK® packages, depending on their level of environmental compliance. ECOPACK® specifications, grade definitions and product status are available at: www.st.com. ECOPACK® is an ST trademark.

5.1 DIP14 package information

Figure 17. DIP14 package mechanical drawing

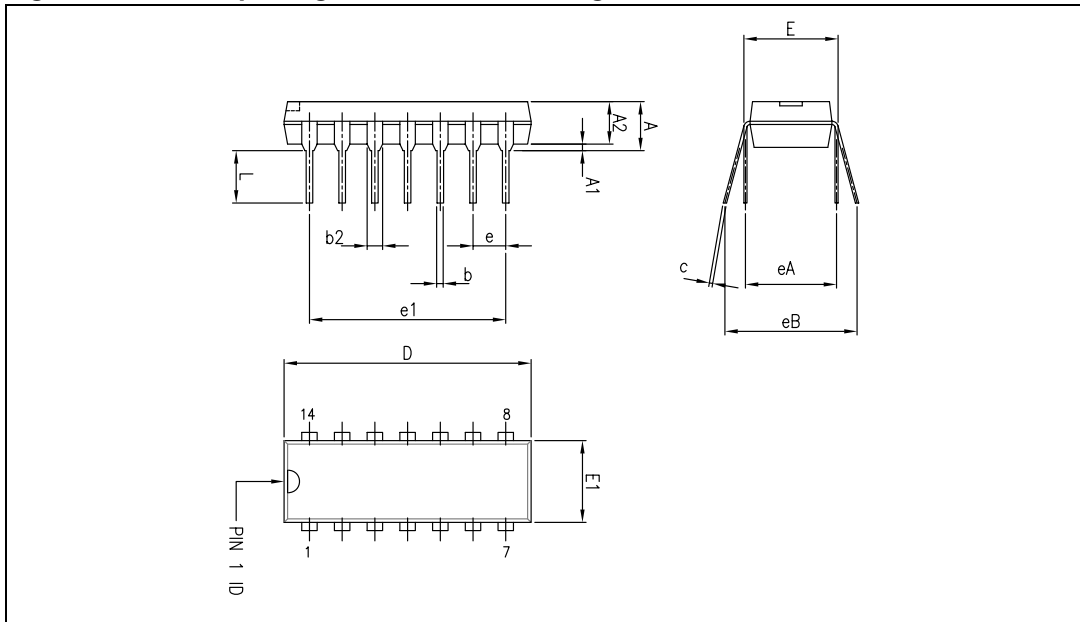

Table 4. DIP14 package mechanical data

Dimensions						
Ref.	Millimeters			Inches		
	Min.	Typ.	Max.	Min.	Typ.	Max.
A			5.33			0.21
A1	0.38			0.015		
A2	2.92	3.30	4.95	0.11	0.13	0.19
b	0.36	0.46	0.56	0.014	0.018	0.022
b2	1.14	1.52	1.78	0.04	0.06	0.07
c	0.20	0.25	0.36	0.007	0.009	0.01
D	18.67	19.05	19.69	0.73	0.75	0.77
E	7.62	7.87	8.26	0.30	0.31	0.32
E1	6.10	6.35	7.11	0.24	0.25	0.28
e		2.54			0.10	
e1		15.24			0.60	
eA		7.62			0.30	
eB			10.92			0.43
L	2.92	3.30	3.81	0.11	0.13	0.15

Note: D and E1 dimensions do not include mold flash or protrusions. Mold flash or protrusions shall not exceed 0.25 mm.

5.2 SO-14 package information

Figure 18. SO-14 package mechanical drawing

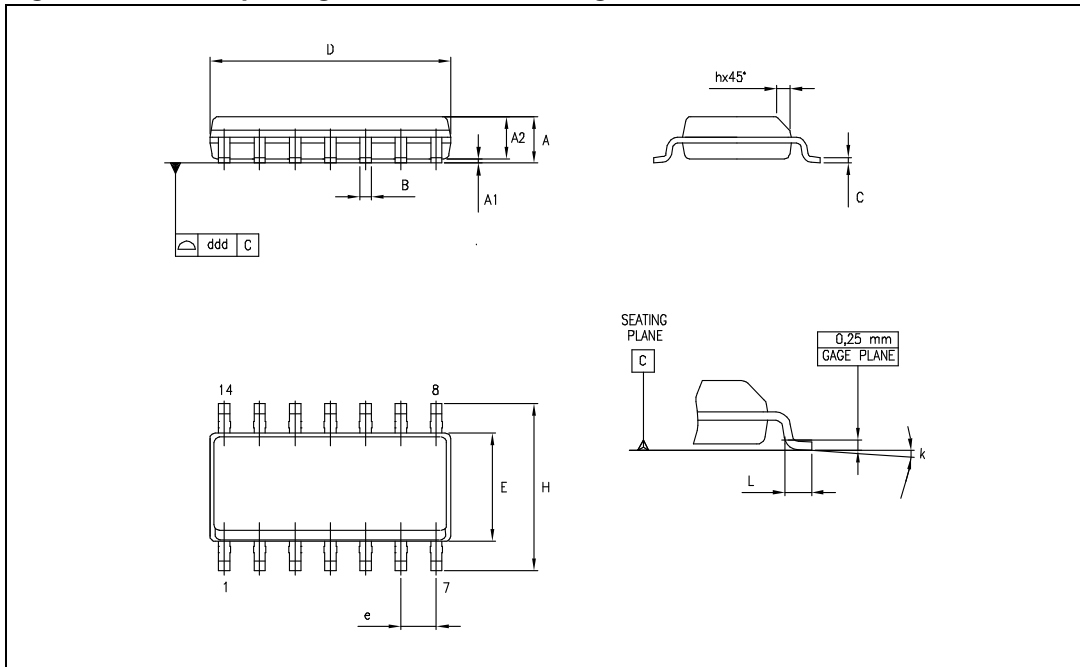

Table 5. SO-14 package mechanical data

Dimensions						
Ref.	Millimeters			Inches		
	Min.	Typ.	Max.	Min.	Typ.	Max.
A	1.35		1.75	0.05		0.068
A1	0.10		0.25	0.004		0.009
A2	1.10		1.65	0.04		0.06
B	0.33		0.51	0.01		0.02
C	0.19		0.25	0.007		0.009
D	8.55		8.75	0.33		0.34
E	3.80		4.0	0.15		0.15
e		1.27			0.05	
H	5.80		6.20	0.22		0.24
h	0.25		0.50	0.009		0.02
L	0.40		1.27	0.015		0.05
k	8° (max.)					
ddd			0.10			0.004

Note: D and F dimensions do not include mold flash or protrusions. Mold flash or protrusions must not exceed 0.15 mm.

6 Ordering information

Table 6. Order codes

Part number	Temperature range	Package	Packing	Marking
NE556N	0°C, +70°C	DIP14	Tube	NE556N
NE556D/DT		SO-14	Tube or tape & reel	NE556
SA556N	-40°C, +105°C	DIP14	Tube	SA556N
SA556D/DT		SO-14	Tube or tape & reel	SA556
SE556N	-55°C, + 125°C	DIP14	Tube	SE556N
SE556D/DT		SO-14	Tube or tape & reel	SE556

7 Revision history

Table 7. Document revision history

Date	Revision	Changes
01-Jun-2003	1	Initial release.
27-Jan-2009	2	Document reformatted. Added I _{OUT} value in Table 1: Absolute maximum ratings and Table 2: Operating conditions . Added ESD tolerance, latch-up tolerance, R _{thja} and R _{thjc} in Table 1: Absolute maximum ratings . Updated Section 5.1: DIP14 package information and Section 5.2: SO-14 package information .

Please Read Carefully:

Information in this document is provided solely in connection with ST products. STMicroelectronics NV and its subsidiaries ("ST") reserve the right to make changes, corrections, modifications or improvements, to this document, and the products and services described herein at any time, without notice.

All ST products are sold pursuant to ST's terms and conditions of sale.

Purchasers are solely responsible for the choice, selection and use of the ST products and services described herein, and ST assumes no liability whatsoever relating to the choice, selection or use of the ST products and services described herein.

No license, express or implied, by estoppel or otherwise, to any intellectual property rights is granted under this document. If any part of this document refers to any third party products or services it shall not be deemed a license grant by ST for the use of such third party products or services, or any intellectual property contained therein or considered as a warranty covering the use in any manner whatsoever of such third party products or services or any intellectual property contained therein.

UNLESS OTHERWISE SET FORTH IN ST'S TERMS AND CONDITIONS OF SALE ST DISCLAIMS ANY EXPRESS OR IMPLIED WARRANTY WITH RESPECT TO THE USE AND/OR SALE OF ST PRODUCTS INCLUDING WITHOUT LIMITATION IMPLIED WARRANTIES OF MERCHANTABILITY, FITNESS FOR A PARTICULAR PURPOSE (AND THEIR EQUIVALENTS UNDER THE LAWS OF ANY JURISDICTION), OR INFRINGEMENT OF ANY PATENT, COPYRIGHT OR OTHER INTELLECTUAL PROPERTY RIGHT.

UNLESS EXPRESSLY APPROVED IN WRITING BY AN AUTHORIZED ST REPRESENTATIVE, ST PRODUCTS ARE NOT RECOMMENDED, AUTHORIZED OR WARRANTED FOR USE IN MILITARY, AIR CRAFT, SPACE, LIFE SAVING, OR LIFE SUSTAINING APPLICATIONS, NOR IN PRODUCTS OR SYSTEMS WHERE FAILURE OR MALFUNCTION MAY RESULT IN PERSONAL INJURY, DEATH, OR SEVERE PROPERTY OR ENVIRONMENTAL DAMAGE. ST PRODUCTS WHICH ARE NOT SPECIFIED AS "AUTOMOTIVE GRADE" MAY ONLY BE USED IN AUTOMOTIVE APPLICATIONS AT USER'S OWN RISK.

Resale of ST products with provisions different from the statements and/or technical features set forth in this document shall immediately void any warranty granted by ST for the ST product or service described herein and shall not create or extend in any manner whatsoever, any liability of ST.

ST and the ST logo are trademarks or registered trademarks of ST in various countries.

Information in this document supersedes and replaces all information previously supplied.

The ST logo is a registered trademark of STMicroelectronics. All other names are the property of their respective owners.

© 2009 STMicroelectronics - All rights reserved

STMicroelectronics group of companies

Australia - Belgium - Brazil - Canada - China - Czech Republic - Finland - France - Germany - Hong Kong - India - Israel - Italy - Japan - Malaysia - Malta - Morocco - Singapore - Spain - Sweden - Switzerland - United Kingdom - United States of America

www.st.com