

# NCP100

## Sub 1.0 V Precision Adjustable Shunt Regulator

The NCP100 is a precision low voltage shunt regulator that is programmable over a voltage range of 0.9 V to 6.0 V. This device features a guaranteed reference accuracy of  $\pm 1.7\%$  at 25°C and  $\pm 2.6\%$  over the entire temperature range of -40°C to 85°C. The NCP100 exhibits a sharp low current turn-on characteristic with a low dynamic impedance of 0.20  $\Omega$  over an operating current range of 100  $\mu\text{A}$  to 20 mA. These characteristics make this device an ideal replacement for zener diodes in numerous application circuits that require a precise low voltage reference. When combined with an optocoupler, the NCP100 can be used as an error amplifier for controlling the feedback loop in isolated low output voltage (2.3 V) switching power supplies. This device is available in TO-92 and in an economical space saving TSOP-5 package.

### Features

- Programmable Output Voltage Range of 0.9 V to 6.0 V
- Voltage Reference Tolerance of  $\pm 1.7\%$
- Sharp Low Current Turn-ON Characteristic
- Low Dynamic Output Impedance of 0.2  $\Omega$  from 100  $\mu\text{A}$  to 20 mA
- Wide Operating Current Range of 80  $\mu\text{A}$  to 20 mA
- TO-92 and Space Saving TSOP-5 Package
- Pb-Free Package is Available

### Applications

- Reference for Single Cell Alkaline, NiCD and NiMH Applications
- Low Output Voltage (2.3 V) Switching Power Supply Error Amp
- Battery Powered Consumer Products
- Portable Test Equipment and Instrumentation

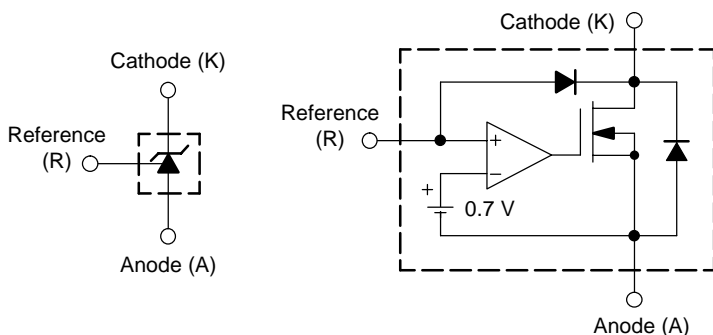

Figure 1. Symbol

Figure 2. Representative Block Diagram



**ON Semiconductor®**

<http://onsemi.com>



Pin 1. Reference  
2. Anode  
3. Cathode

**TO-92 (TO-226)  
LP SUFFIX  
CASE 029**



**TSOP-5  
SN SUFFIX  
CASE 483**

### PIN CONNECTIONS AND MARKING DIAGRAM

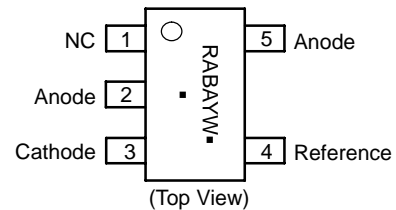

RAB = Device Code  
A = Assembly Location  
Y = Year  
W = Work Week  
▪ = Pb-Free Package

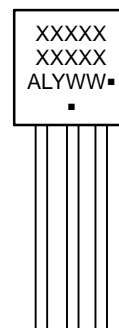

XXXXX = Specific Device Code  
A = Assembly Location  
L = Wafer Lot  
Y = Year  
WW = Work Week  
▪ = Pb-Free Package  
(Note: Microdot may be in either location)

### ORDERING INFORMATION

Device	Package	Shipping†
NCP100SNT1	TSOP-5	3000 / Tape & Reel
NCP100SNT1G	TSOP-5 (Pb-Free)	3000 / Tape & Reel
NCP100ALPRPG	TO-92 (Pb-Free)	2000 / Ammo Pack

†For information on tape and reel specifications, including part orientation and tape sizes, please refer to our Tape and Reel Packaging Specifications Brochure, BRD8011/D.

# NCP100

## MAXIMUM RATINGS (T<sub>A</sub> = 25°C, unless otherwise noted.)

Rating	Symbol	Value	Unit
Cathode to Anode Voltage (Note 1)	V <sub>KA</sub>	7.0	V
Cathode Current Range, Continuous (Note 2)	I <sub>K</sub>	-20 to 25	mA
Reference Input Current Range, Continuous (Note 1)	I <sub>REF</sub>	-0.05 to 2.0	mA
Thermal Resistance LP Suffix, TO-92 Package Thermal Resistance, Junction-to-Ambient Thermal Resistance, Junction-to-Lead SN Suffix, TSOP-5 Package Thermal Resistance, Junction-to-Ambient	R <sub>θJA</sub> R <sub>psi-J-Anode lead</sub> R <sub>θJA</sub>	168 32 225	°C/W
Operating Junction Temperature Range	T <sub>J</sub>	-40 to 125	°C
Storage Temperature Range	T <sub>stg</sub>	-65 to 150	°C

Stresses exceeding Maximum Ratings may damage the device. Maximum Ratings are stress ratings only. Functional operation above the Recommended Operating Conditions is not implied. Extended exposure to stresses above the Recommended Operating Conditions may affect device reliability.

- This device series contains ESD protection and exceeds the following tests:  
Human Body Model 4000 V per JESD-22, Method A114B.  
Machine Model Method 400 V.
- The maximum package power dissipation limit must not be exceeded.

$$P_D = \frac{T_{J(max)} - T_A}{R_{\theta JA}}$$

## RECOMMENDED OPERATING CONDITIONS

Condition	Symbol	Min	Max	Unit
Cathode-to-Anode Voltage Range (Note 3)	V <sub>KA</sub>	0.9	6.0	V
Cathode Current Range	I <sub>K</sub>	0.1	20	mA

- Valid device operation is not guaranteed if V<sub>ka</sub> is allowed to fall below 0.875 V at any time over the operating temperature range of -40°C to +85°C.

# NCP100

## ELECTRICAL CHARACTERISTICS (T<sub>A</sub> = 25°C, unless otherwise noted.)

Characteristic	Symbol	Min	Typ	Max	Unit
Reference Voltage (I <sub>KA</sub> = 10 mA, Figure 3) V <sub>KA</sub> = 0.9 V T <sub>A</sub> = 25°C T <sub>A</sub> = 0°C to 70°C T <sub>A</sub> = -40°C to 85°C V <sub>KA</sub> = 1.0 V T <sub>A</sub> = 25°C T <sub>A</sub> = 0°C to 70°C T <sub>A</sub> = -40°C to 85°C	V <sub>REF</sub>	0.684 0.682 0.678 0.686 0.684 0.680	0.696 – – 0.698 – –	0.708 0.710 0.714 0.710 0.712 0.716	V
Reference Input Voltage Change Over Temperature V <sub>KA</sub> = 1.0 V, I <sub>K</sub> = 10 mA, T <sub>A</sub> = -40°C to 85°C, Figure 3 (Notes 4, 5)	ΔV <sub>REF</sub>	–	1.0	12	mV
Reference Input Voltage Change Over Programmed Cathode Voltage (I <sub>K</sub> = 10 mA, Figure 3) V <sub>KA</sub> = 0.9 V to 1.0 V V <sub>KA</sub> = 1.0 V to 6.0 V	Reg <sub>line</sub>	-5.0 0	0.2 6.7	5.0 12	mV
Ratio of Reference Input Voltage Change to Cathode Voltage Change V <sub>KA</sub> = 0.9 V to 6.0 V, I <sub>K</sub> = 10 mA, Figure 3	$\frac{\Delta V_{REF}}{\Delta V_{KA}}$	–	1.3	2.4	mV/V
Reference Input Current (V <sub>KA</sub> = 1.0 V, I <sub>K</sub> = 10 mA)	I <sub>REF</sub>	-100	-30	100	nA
Minimum Cathode Current for Regulation	I <sub>K(min)</sub>	–	80	–	μA
Cathode Off-State Current (V <sub>KA</sub> = 6.0 V, V <sub>REF</sub> = 0 V)	I <sub>K(off)</sub>	–	70	90	μA
Dynamic Output Impedance V <sub>KA</sub> = 1.0 V, I <sub>K</sub> = 100 μA to 20 mA, f ≤ 1.0 kHz, Figure 3	Z <sub>KA</sub>	–	0.2	–	Ω

- Low duty cycle pulse techniques are used during testing to maintain the junction temperatures as close to ambient as possible.
- The ΔV<sub>REF</sub> parameter is defined as the difference between the maximum and minimum values obtained over the ambient temperature range of -40°C to 85°C.

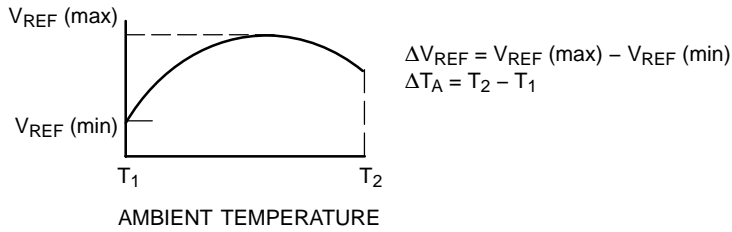

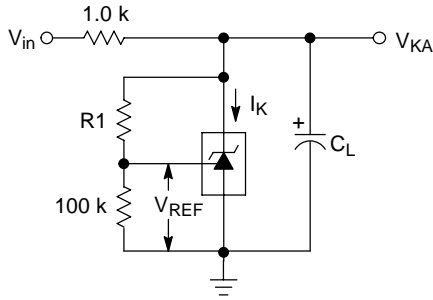

Figure 3. General Test Circuit

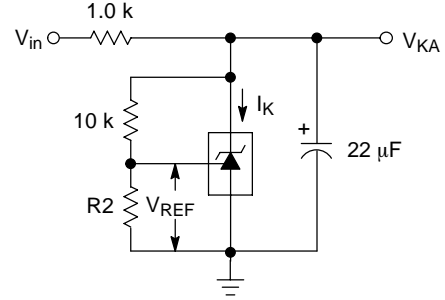

Figure 4. Test Circuit for Reference Input Voltage Change vs. Cathode Voltage

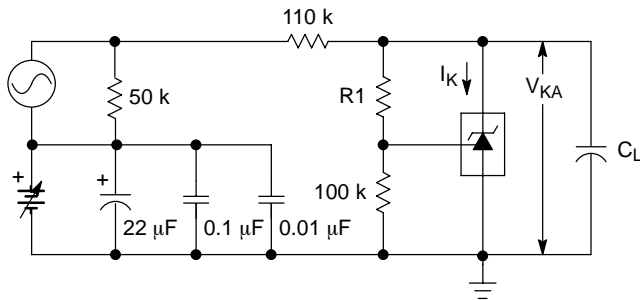

Figure 5. Test Circuit for Dynamic Impedance vs. Frequency

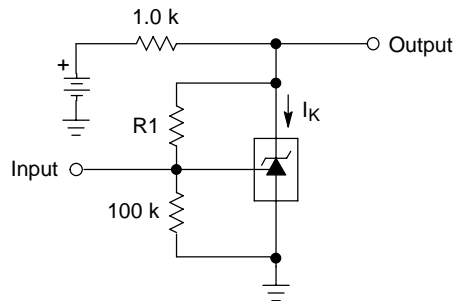

Figure 6. Test Circuit for Spectral Noise Density

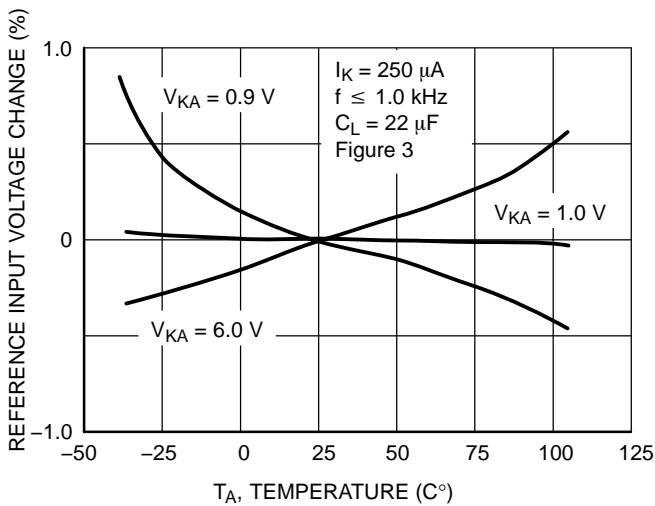

Figure 7. Reference Input Voltage Change vs. Ambient Temperature

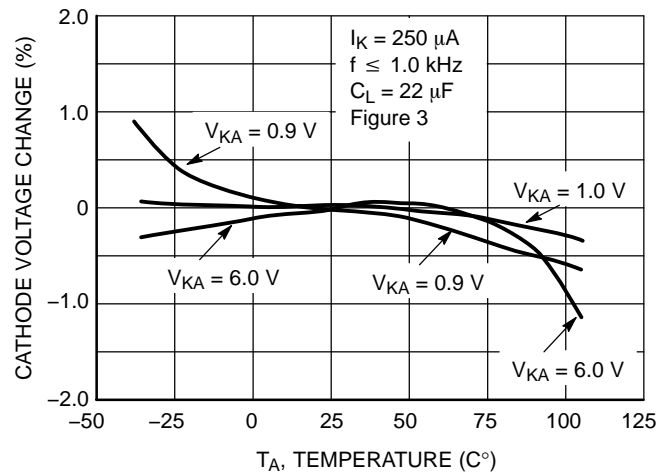

Figure 8. Cathode Voltage Change vs. Ambient Temperature

# NCP100

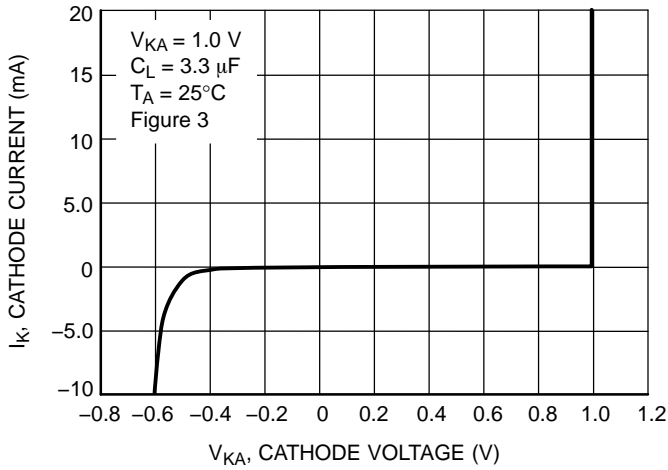

Figure 9. Cathode Current vs. Cathode Voltage

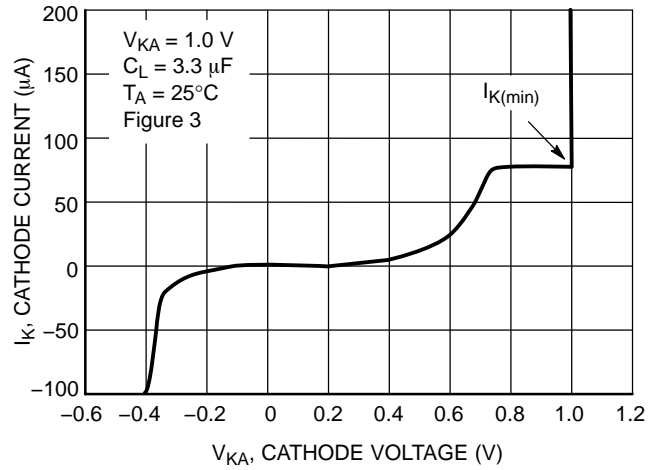

Figure 10. Cathode Current vs. Cathode Voltage

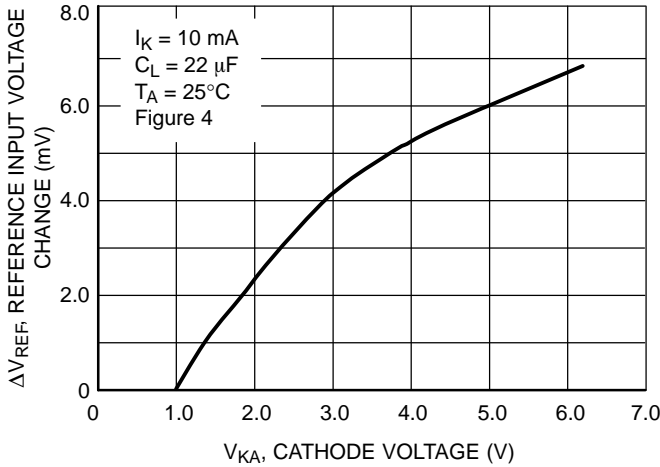

Figure 11. Reference Input Voltage Change vs. Cathode Voltage

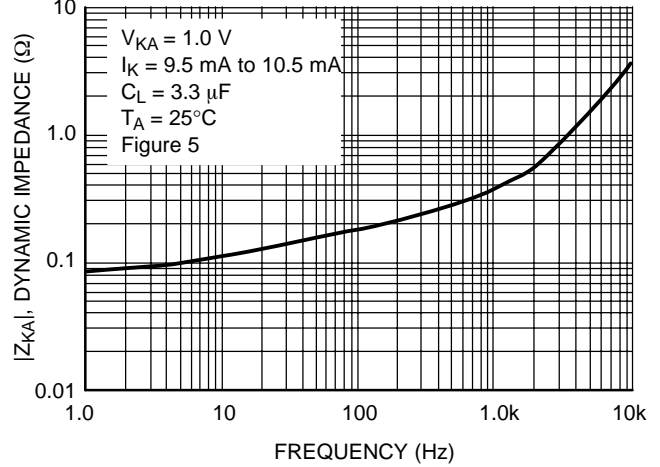

Figure 12. Dynamic Impedance vs. Frequency

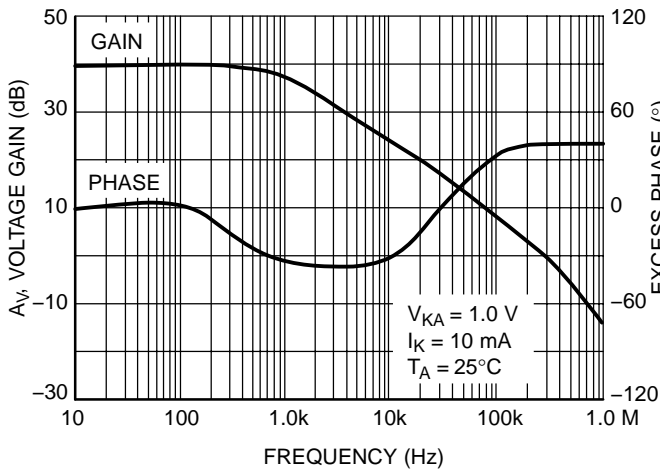

Figure 13. Small-Signal Voltage Gain and Phase vs. Frequency

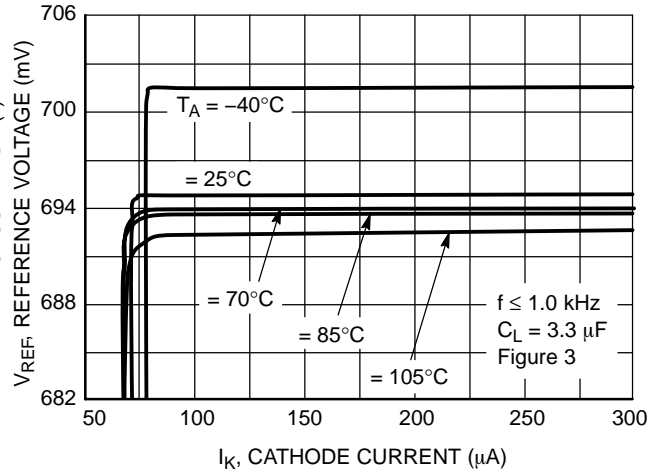
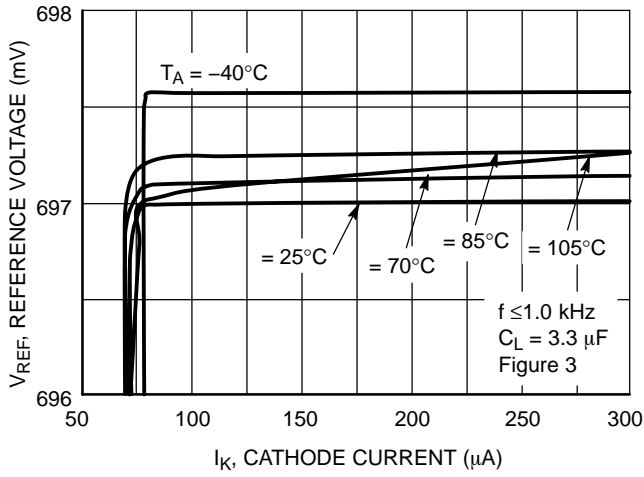
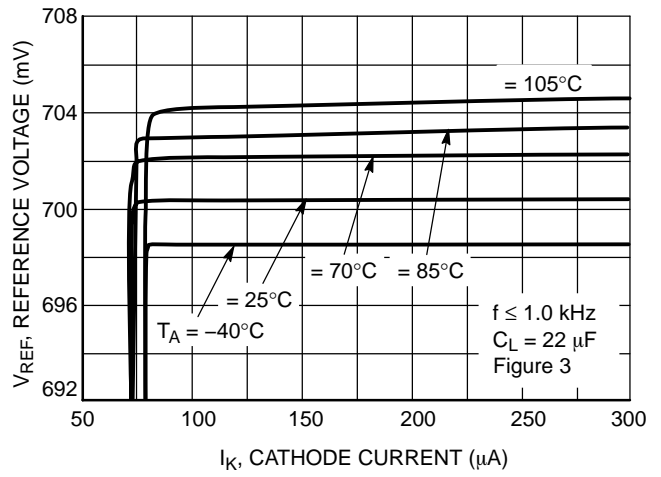

Figure 14. Reference Voltage vs. Cathode Current for  $V_{KA} = 0.9 V$

# NCP100



**Figure 15. Reference Voltage vs. Cathode Current for  $V_{KA} = 1.0 \text{ V}$**



**Figure 16. Reference Voltage vs. Cathode Current for  $V_{KA} = 6.0 \text{ V}$**

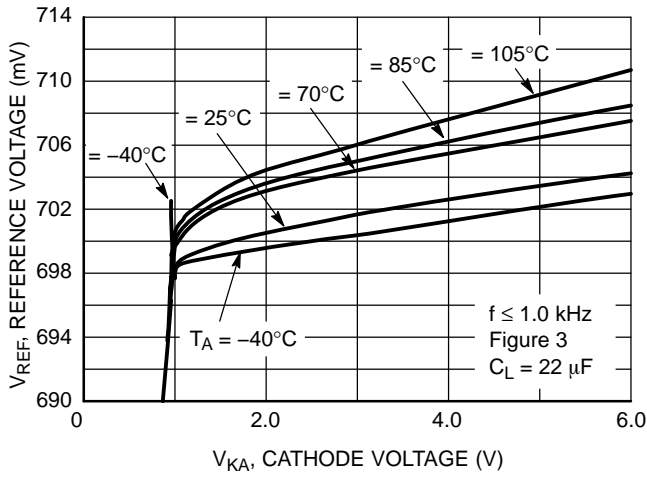

**Figure 17. Reference Voltage vs. Cathode Current**

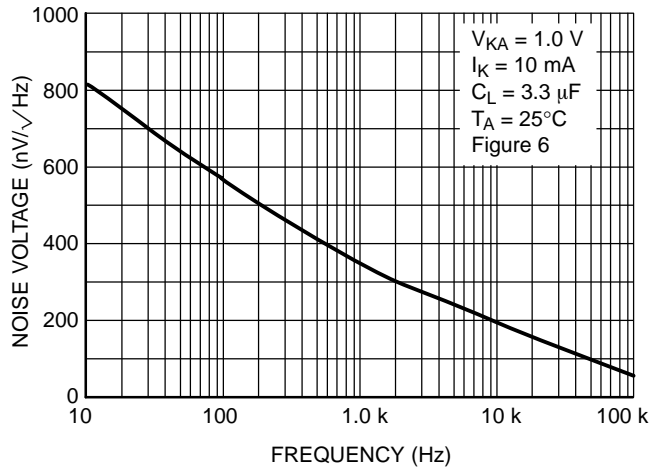

**Figure 18. Spectral Noise Density**

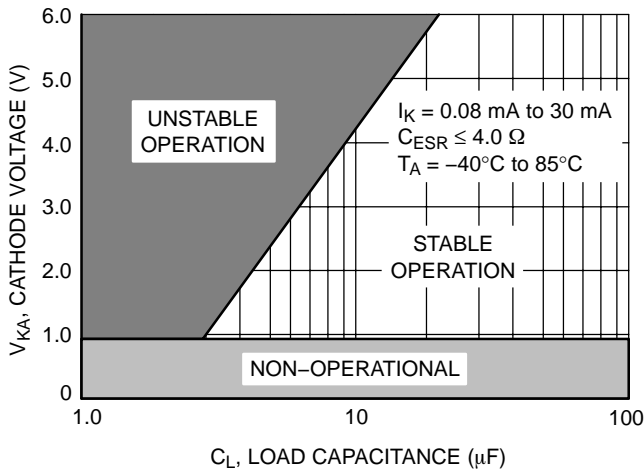

**Figure 19. Stability Boundary Conditions**

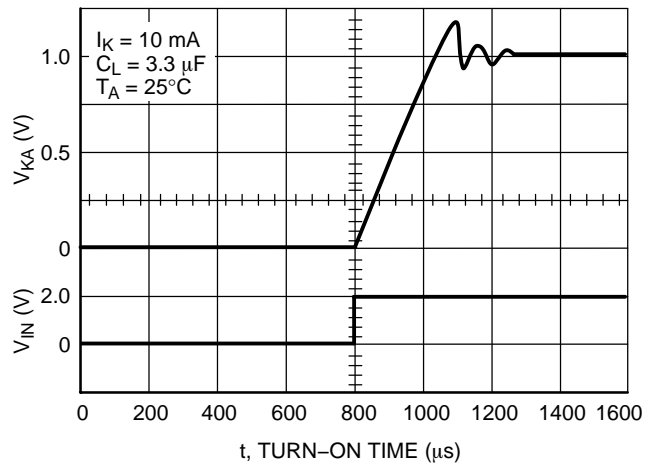

**Figure 20. Turn-On Time**

APPLICATIONS INFORMATION

The NCP100 is an adjustable shunt regulator similar to the industry standard 431-type regulators. Each device is laser trimmed at wafer probe to allow for tight reference accuracy and low reference voltage shift over the full operating temperature range of  $-40^{\circ}\text{C}$  to  $+85^{\circ}\text{C}$  (Figure 7).

The nominal value for the reference is 0.698 V. This lower voltage allows the device to be used in low voltage applications where the traditional 1.25 V and 2.5 V references are not suitable.

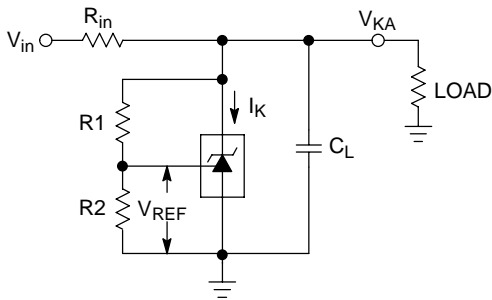

Figure 21. Typical Application Circuit

The typical application circuit for this device is shown in Figure 21. The cathode voltage can be programmed between 0.9 V to 6.0 V to allow for proper operation by setting the R1/R2 resistor divider network values. The following equation can be used in calculating the cathode voltage ( $V_{KA}$ ). Note, if  $V_{KA}$  is known then the ratio of R1 and R2 can be determined from this equation as well.

$$V_{KA} = V_{REF} \left( 1 + \frac{R1}{R2} \right) + I_{REF} R1$$

The table below shows the required R1/R2 values using 1.0% resistors for commonly used voltages.

$V_{KA}$ (V)	R1 (k $\Omega$ )	R2 (k $\Omega$ )
0.9	30	100
1.0	43.2	100
1.8	158	100
3.3	374	100
5.0	619	100
6.0	750	100

Because the error amplifier is a CMOS design the value of  $I_{REF}$  is extremely low allowing it to be neglected for most applications. The low  $I_{REF}$  also allows for higher R1 and R2 values keeping current consumption very low.

The NCP100 is especially well suited for lower voltage applications, particularly at  $V_{KA} = 1.0$  V. As is seen in Figures 7 and 8, this device exhibits excellent cathode and reference voltage flatness across the  $-40^{\circ}\text{C}$  to  $+85^{\circ}\text{C}$  temperature range.

In Figure 21, the input resistor ( $R_{in}$ ) is nominally set to 1.0 k $\Omega$ . For proper operation, once  $V_{in}$ , R1 and R2 are set, the resistance and power value of  $R_{in}$  can be determined by the following equation.

$$R_{in} = \frac{V_{in} - V_{KA}}{I_K + I_L + \left( \frac{V_{KA}}{R1 + R2} \right)}$$

The maximum current that will flow through  $R_{in}$  must be determined. This is the sum of the maximum values of cathode current, resistor divider network current, and load current. With  $V_{in}$  set, the difference ( $V_{in} - V_{KA}$ ) is now constant. This value is divided by the maximum current calculated above to arrive at the value of  $R_{in}$ . Once the value of  $R_{in}$  is calculated, its minimum power rating is easily derived by:

$$P_{in} = (I_{in})^2 R_{in}$$

Once these values are determined, it should be verified that the minimum and maximum values of  $I_K$  are within the recommended range of 0.1 mA to 20 mA under the worst case conditions.

For stability, the NCP100 requires an output capacitor between the cathode and anode. Figure 19 shows the capacitance boundary values required for stable operation across the  $-40^{\circ}\text{C}$  to  $85^{\circ}\text{C}$  temperature range. The goal is to remain to the right of the curve for any programmed cathode voltages. For example, if the  $V_{KA}$  is programmed to 1.0 V, then a load capacitor value of 3.0  $\mu\text{F}$  or greater would be selected. The load capacitor's Equivalent Series Resistance, ESR, should be less than 4.0  $\Omega$ . Both the capacitance and ESR values should be checked across the anticipated application temperature range to insure that the values meet the requirements stated above.

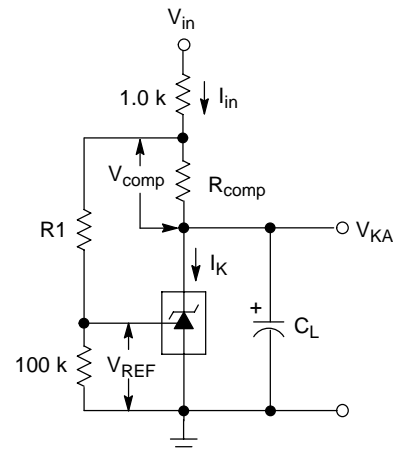

Figure 22. Negative Dynamic Impedance Circuit

One unique use for the NCP100 is that it can be configured for negative dynamic impedance as shown in Figure 22. This circuit is equivalent to Figure 21 with the addition of a small value resistor  $R_{comp}$  in the cathode circuit. The regulated voltage output remains across the NCP100 cathode and anode leads. The voltage programming and stability requirements remain the same as in the typical application shown in Figure 21.

# NCP100

The circuit performs the same as the one in Figure 21 with the exception of the effects of  $R_{comp}$ . As  $I_K$  increases, the voltage across  $R_{comp}$  also increases by:

$$V_{comp} = I_K R_{comp}$$

$V_{comp}$  effectively adjusts the NCP100 programmed  $V_{KA}$  voltage slightly down since the R1/R2 voltage divider will try to hold the point it is connected to at the programmed voltage. The regulator  $V_{KA}$  will now be lowered by the value of the  $V_{comp}$ . This effect can compensate for the NCP100's intrinsic positive impedance versus cathode current ( $I_K$ ) to allow for  $0 \Omega$  or even a negative dynamic impedance.

Figure 23 shows this phenomenon for a program voltage of 1.0 V. The NCP100 intrinsic positive dynamic impedance response is the  $R_{comp} = 0 \Omega$  curve. A  $0 \Omega$  dynamic impedance regulator response is realized with  $R_{comp} = 0.15 \Omega$ . Negative dynamic impedance responses are achieved with  $R_{comp} > 0.15 \Omega$ .

Figure 24 shows the characteristic at a programmed  $V_{KA}$  of 6.0 V. The  $0 \Omega$  dynamic impedance value corresponds to  $R_{comp} = 2.9 \Omega$ .

Figure 25 shows the dynamic impedance versus cathode compensation resistance for programmed voltages of 1.0 V, 3.3 V and 6.0 V. It can be seen that any value up to the positive intrinsic dynamic impedance of the NCP100 can be realized. The other limit is that with a high enough negative dynamic impedance, the NCP100 V may drop below the minimum operating  $V_{KA}$  voltage of 0.9 V, which can result in unpredictable performance.

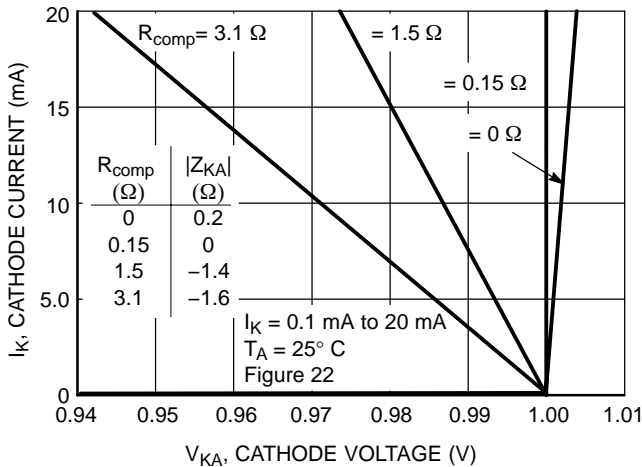

Figure 23. Cathode Current vs. Cathode Voltage for Programmed  $V_{KA} = 1.0 \text{ V}$

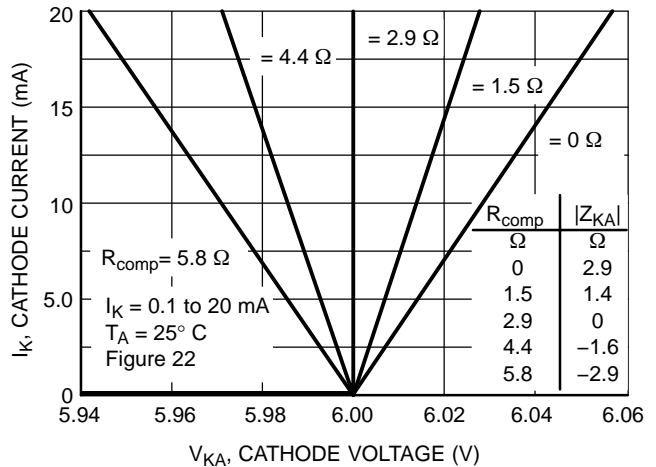

Figure 24. Cathode Current vs. Cathode Voltage for Programmed  $V_{KA} = 6.0 \text{ V}$

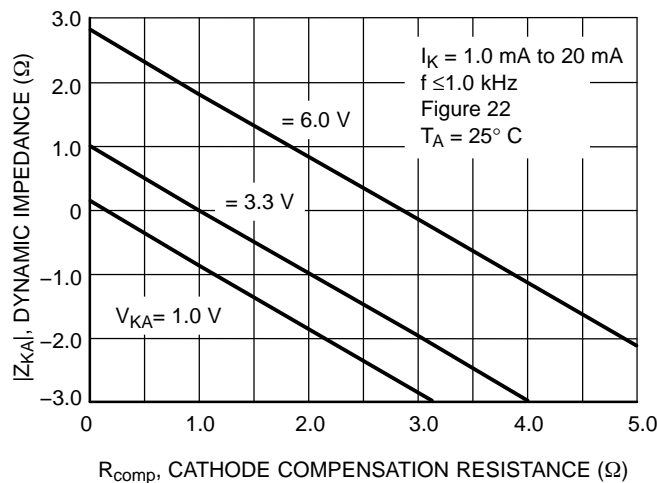

Figure 25. Dynamic Impedance vs. Cathode Compensation Resistance



# NCP100

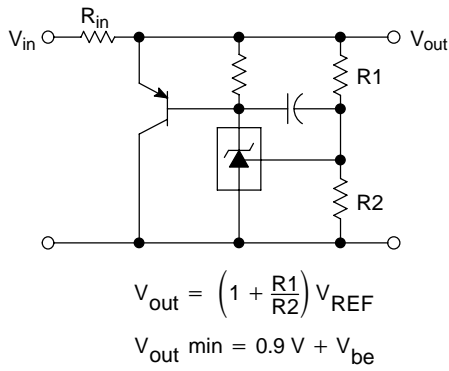

Figure 26. High Current Shunt Regulator

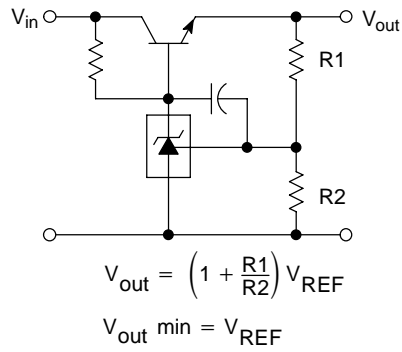

Figure 27. Low Dropout Series Pass Regulator

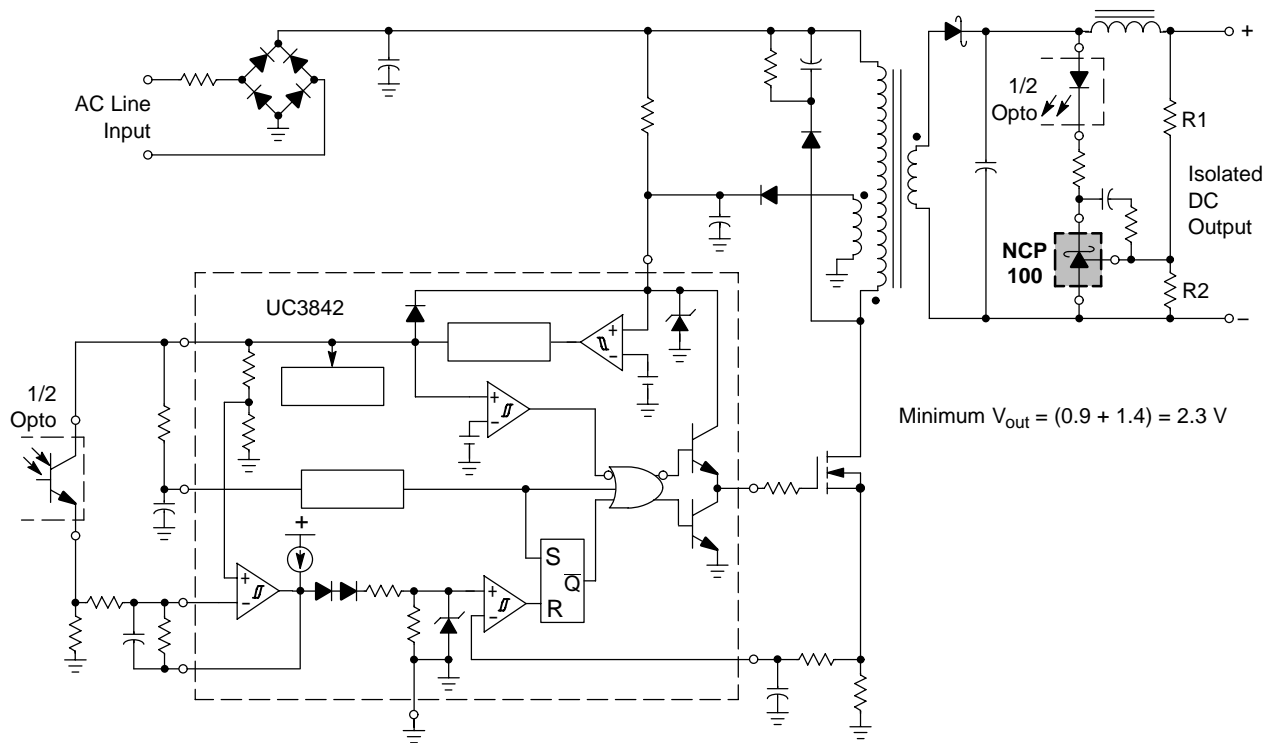

Figure 28. Offline Converter with Isolated DC Output

The circuit in Figure 28 uses the NCP100 as a compensated amplifier for controlling the feedback loop of an isolated output line powered converter. This device allows the converter to directly regulate the output voltage at a significantly lower level than obtainable with the

common TL431 device family. The output voltage is programmed by the resistors R1 and R2. The minimum regulated DC output is limited to the sum of the lowest allowable cathode to anode voltage (0.9 V) and the forward drop of the optocoupler light emitting diode (1.4 V).

# NCP100

## TO-92 EIA RADIAL TAPE ON REEL

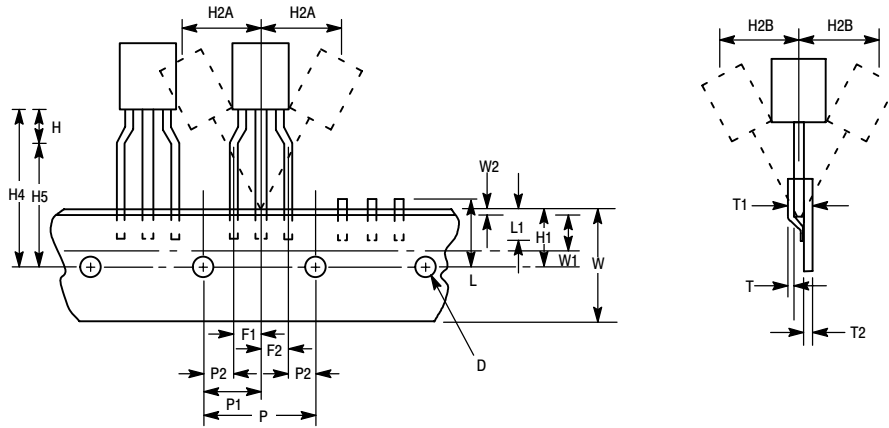

Figure 29. Device Positioning on Tape

Symbol	Item	Specification			
		Inches		Millimeter	
		Min	Max	Min	Max
D	Tape Feedhole Diameter	0.1496	0.1653	3.8	4.2
D2	Component Lead Thickness Dimension	0.015	0.020	0.38	0.51
F1, F2	Component Lead Pitch	0.0945	0.110	2.4	2.8
H	Bottom of Component to Seating Plane	.059	.156	1.5	4.0
H1	Feedhole Location	0.3346	0.3741	8.5	9.5
H2A	Deflection Left or Right	0	0.039	0	1.0
H2B	Deflection Front or Rear	0	0.051	0	1.0
H4	Feedhole to Bottom of Component	0.7086	0.768	18	19.5
H5	Feedhole to Seating Plane	0.610	0.649	15.5	16.5
L	Defective Unit Clipped Dimension	0.3346	0.433	8.5	11
L1	Lead Wire Enclosure	0.09842	—	2.5	—
P	Feedhole Pitch	0.4921	0.5079	12.5	12.9
P1	Feedhole Center to Center Lead	0.2342	0.2658	5.95	6.75
P2	First Lead Spacing Dimension	0.1397	0.1556	3.55	3.95
T	Adhesive Tape Thickness	0.06	0.08	0.15	0.20
T1	Overall Taped Package Thickness	—	0.0567	—	1.44
T2	Carrier Strip Thickness	0.014	0.027	0.35	0.65
W	Carrier Strip Width	0.6889	0.7481	17.5	19
W1	Adhesive Tape Width	0.2165	0.2841	5.5	6.3
W2	Adhesive Tape Position	.0059	0.01968	.15	0.5

NOTES:

1. Maximum alignment deviation between leads not to be greater than 0.2 mm.
2. Defective components shall be clipped from the carrier tape such that the remaining protrusion (L) does not exceed a maximum of 11 mm.
3. Component lead to tape adhesion must meet the pull test requirements.
4. Maximum non-cumulative variation between tape feed holes shall not exceed 1 mm in 20 pitches.
5. Hold down tape not to extend beyond the edge(s) of carrier tape and there shall be no exposure of adhesive.
6. No more than 1 consecutive missing component is permitted.
7. A tape trailer and leader, having at least three feed holes is required before the first and after the last component.
8. Splices will not interfere with the sprocket feed holes.

# NCP100

## PACKAGE DIMENSIONS

TO-92 (TO-226)  
CASE 29-11  
ISSUE AL

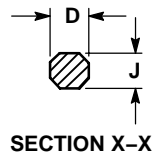
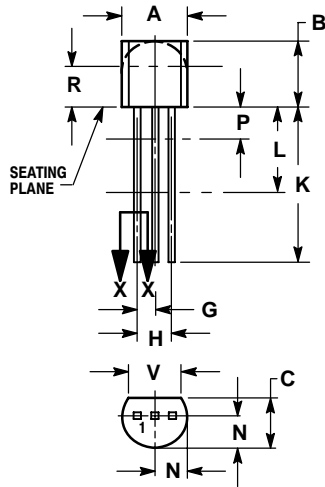

NOTES:

1. DIMENSIONING AND TOLERANCING PER ANSI Y14.5M, 1982.
2. CONTROLLING DIMENSION: INCH.
3. CONTOUR OF PACKAGE BEYOND DIMENSION R IS UNCONTROLLED.
4. LEAD DIMENSION IS UNCONTROLLED IN P AND BEYOND DIMENSION K MINIMUM.

DIM	INCHES		MILLIMETERS	
	MIN	MAX	MIN	MAX
A	0.175	0.205	4.45	5.20
B	0.170	0.210	4.32	5.33
C	0.125	0.165	3.18	4.19
D	0.016	0.021	0.407	0.533
G	0.045	0.055	1.15	1.39
H	0.095	0.105	2.42	2.66
J	0.015	0.020	0.39	0.50
K	0.500	---	12.70	---
L	0.250	---	6.35	---
N	0.080	0.105	2.04	2.66
P	---	0.100	---	2.54
R	0.115	---	2.93	---
V	0.135	---	3.43	---

# NCP100

## PACKAGE DIMENSIONS

### TSOP-5 SN SUFFIX PLASTIC PACKAGE CASE 483-02 ISSUE C

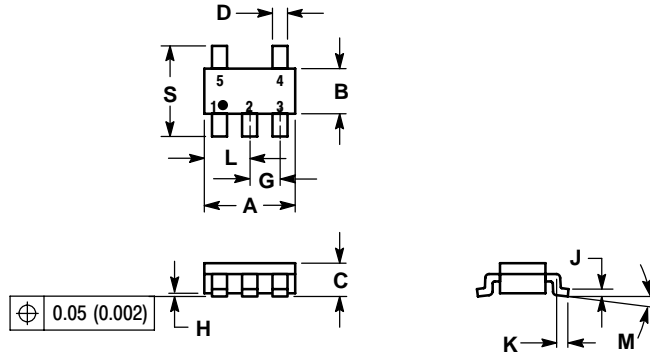

#### NOTES:

1. DIMENSIONING AND TOLERANCING PER ANSI Y14.5M, 1982.
2. CONTROLLING DIMENSION: MILLIMETER.
3. MAXIMUM LEAD THICKNESS INCLUDES LEAD FINISH THICKNESS. MINIMUM LEAD THICKNESS IS THE MINIMUM THICKNESS OF BASE MATERIAL.
4. A AND B DIMENSIONS DO NOT INCLUDE MOLD FLASH, PROTRUSIONS, OR GATE BURRS.

DIM	MILLIMETERS		INCHES	
	MIN	MAX	MIN	MAX
A	2.90	3.10	0.1142	0.1220
B	1.30	1.70	0.0512	0.0669
C	0.90	1.10	0.0354	0.0433
D	0.25	0.50	0.0098	0.0197
G	0.85	1.05	0.0335	0.0413
H	0.013	0.100	0.0005	0.0040
J	0.10	0.26	0.0040	0.0102
K	0.20	0.60	0.0079	0.0236
L	1.25	1.55	0.0493	0.0610
M	0	10	0	10
S	2.50	3.00	0.0985	0.1181

### SOLDERING FOOTPRINT\*

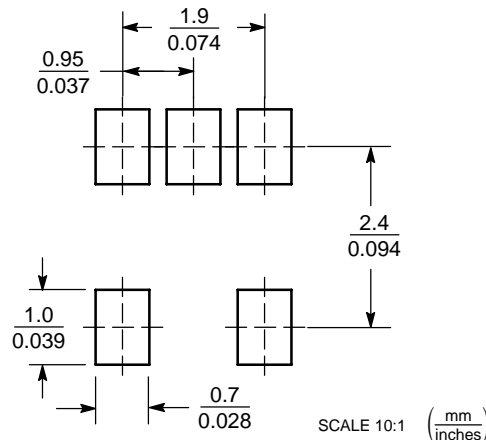

\*For additional information on our Pb-Free strategy and soldering details, please download the ON Semiconductor Soldering and Mounting Techniques Reference Manual, SOLDERRM/D.

ON Semiconductor and are registered trademarks of Semiconductor Components Industries, LLC (SCILLC). SCILLC reserves the right to make changes without further notice to any products herein. SCILLC makes no warranty, representation or guarantee regarding the suitability of its products for any particular purpose, nor does SCILLC assume any liability arising out of the application or use of any product or circuit, and specifically disclaims any and all liability, including without limitation special, consequential or incidental damages. "Typical" parameters which may be provided in SCILLC data sheets and/or specifications can and do vary in different applications and actual performance may vary over time. All operating parameters, including "Typicals" must be validated for each customer application by customer's technical experts. SCILLC does not convey any license under its patent rights nor the rights of others. SCILLC products are not designed, intended, or authorized for use as components in systems intended for surgical implant into the body, or other applications intended to support or sustain life, or for any other application in which the failure of the SCILLC product could create a situation where personal injury or death may occur. Should Buyer purchase or use SCILLC products for any such unintended or unauthorized application, Buyer shall indemnify and hold SCILLC and its officers, employees, subsidiaries, affiliates, and distributors harmless against all claims, costs, damages, and expenses, and reasonable attorney fees arising out of, directly or indirectly, any claim of personal injury or death associated with such unintended or unauthorized use, even if such claim alleges that SCILLC was negligent regarding the design or manufacture of the part. SCILLC is an Equal Opportunity/Affirmative Action Employer. This literature is subject to all applicable copyright laws and is not for resale in any manner.

### PUBLICATION ORDERING INFORMATION

**LITERATURE FULFILLMENT:**  
Literature Distribution Center for ON Semiconductor  
P.O. Box 5163, Denver, Colorado 80217 USA  
**Phone:** 303-675-2175 or 800-344-3860 Toll Free USA/Canada  
**Fax:** 303-675-2176 or 800-344-3867 Toll Free USA/Canada  
**Email:** orderlit@onsemi.com

**N. American Technical Support:** 800-282-9855 Toll Free  
USA/Canada  
**Europe, Middle East and Africa Technical Support:**  
Phone: 421 33 790 2910  
**Japan Customer Focus Center**  
Phone: 81-3-5773-3850

**ON Semiconductor Website:** [www.onsemi.com](http://www.onsemi.com)

**Order Literature:** <http://www.onsemi.com/orderlit>

For additional information, please contact your local Sales Representative