

NB7V33M

1.8V / 2.5V, 10GHz ÷4 Clock Divider with CML Outputs

Multi-Level Inputs w/ Internal Termination

Description

The NB7V33M is a differential ÷4 Clock divider with asynchronous reset. The differential Clock inputs incorporate internal 50 Ω termination resistors and will accept LVPECL, CML and LVDS logic levels. The NB7V33M produces a ÷4 output copy of an input Clock operating up to 10 GHz with minimal jitter. The Reset pin is asserted on the rising edge. Upon powerup, the internal flip-flops will attain a random state; the Reset allows for the synchronization of multiple NB7V33M's in a system. The 16 mA differential CML output provides matching internal 50 Ω termination which guarantees 400 mV output swing when externally receiver terminated with 50 Ω to V_{CC}.

The NB7V33M is the ÷4 version of the NB7V32M (÷2) and is offered in a low profile 3 mm x 3 mm 16-pin QFN package.

The NB7V33M is a member of the GigaComm™ family of high performance clock products. Application notes, models, and support documentation are available at www.onsemi.com.

Features

- Maximum Input Clock Frequency > 10 GHz, typical
- 260 ps Typical Propagation Delay
- 35 ps Typical Rise and Fall Times
- Differential CML Outputs, 400 mV Peak-to-Peak, Typical
- Operating Range: V_{CC} = 1.71 V to 2.625 V with GND = 0 V
- Internal 50 Ω Input Termination Resistors
- Random Clock Jitter < 0.8 ps RMS
- QFN-16 Package, 3 mm x 3 mm
- -40°C to +85°C Ambient Operating Temperature
- These are Pb-Free Devices



ON Semiconductor®

<http://onsemi.com>

MARKING DIAGRAM*

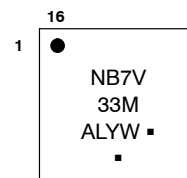

- A = Assembly Location
- L = Wafer Lot
- Y = Year
- W = Work Week
- = Pb-Free Package

(Note: Microdot may be in either location)

*For additional marking information, refer to Application Note AND8002/D.

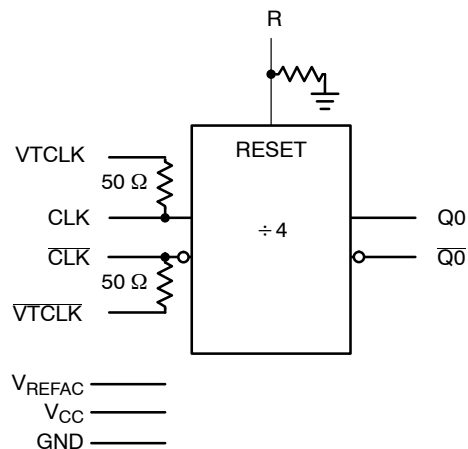

Figure 1. Simplified Logic Diagram

ORDERING INFORMATION

See detailed ordering and shipping information in the package dimensions section on page 9 of this data sheet.

NB7V33M

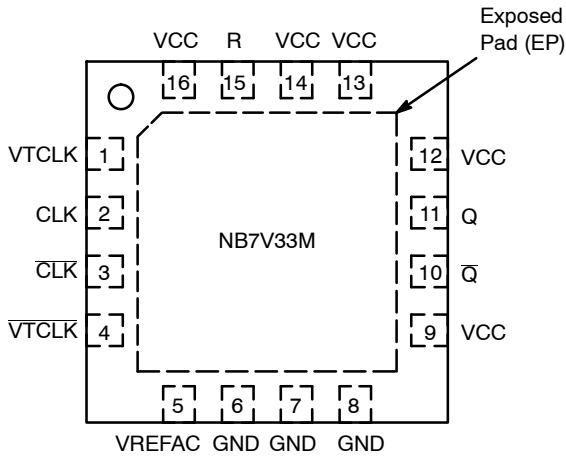

Figure 2. Pin Configuration (Top View)

Table 1. TRUTH TABLE

CLK	CLK	R	Q	Q
x	x	H	L	H
Z	W	L	CLK ÷ 4	CLK ÷ 4

Z = Low to High Transition
W = High to Low Transition
X = Don't Care

Table 2. PIN DESCRIPTION

Pin	Name	I/O	Description
1	VTCLK	-	Internal 50 Ω Termination Pin for CLK
2	CLK	LVPECL, CML, LVDS Input	Non-inverted Differential CLK Input. Note 1.
3	CLK	LVPECL, CML, LVDS Input	Inverted Differential CLK Input. Note 1.
4	VTCLK	-	Internal 50 Ω Termination Pin for CLK
5	VREFAC	-	Internally Generated Output Voltage Reference for Capacitor-Coupled Inputs, Only
6	GND	-	Negative Supply Voltage
7	GND	-	Negative Supply Voltage
8	GND	-	Negative Supply Voltage
9	VCC	-	Positive Supply Voltage. Note 2.
10	Q	CML Output	Inverted Differential Output
11	Q	CML Output	Non-Inverted Differential Output
12	VCC	-	Positive Supply Voltage. Note 2.
13	VCC	-	Positive Supply Voltage. Note 2.
14	VCC	-	Positive Supply Voltage. Note 2.
15	R	LVC MOS Input	Asynchronous Reset Input. Internal 75 kΩ pulldown to GND.
16	VCC	-	Positive Supply Voltage. Note 2.
-	EP	-	The Exposed Pad (EP) on the QFN-16 package bottom is thermally connected to the die for improved heat transfer out of package. The exposed pad must be attached to a heat-sinking conduit. The pad is electrically connected to the die, and must be electrically and thermally connected to GND on the PC board.

1. In the differential configuration when the input termination pins (VTCLK/VTCLK) are connected to a common termination voltage or left open, and if no signal is applied on CLK/CLK input, then the device will be susceptible to self-oscillation. Q/Q outputs have internal 50 Ω source termination resistors.
2. All V_{CC} and GND pins must be externally connected to a power supply for proper operation.

NB7V33M

Table 3. ATTRIBUTES

Characteristics		Value
ESD Protection	Human Body Model Machine Model	> 4 kV > 200 V
R _{PD} – Reset Input Pulldown Resistor		75 kΩ
Moisture Sensitivity (Note 3)	QFN16	Level 1
Flammability Rating	Oxygen Index: 28 to 34	UL 94 V-0 @ 0.125 in
Transistor Count		190
Meets or exceeds JEDEC Spec EIA/JESD78 IC Latchup Test		

3. For additional information, see Application Note AND8003/D.

Table 4. MAXIMUM RATINGS

Symbol	Parameter	Condition 1	Condition 2	Rating	Unit
V _{CC}	Positive Power Supply	GND = 0 V		3.0	V
V _{IN}	Positive Input Voltage	GND = 0 V		-0.5 to V _{CC} +0.5	V
V _{INPP}	Differential Input Voltage D - \bar{D}			1.89	V
I _{IN}	Input Current Through R _T (50 Ω Resistor)			± 40	mA
I _{OUT}	Output Current Through R _T (50 Ω Resistor)			± 40	mA
I _{VREFAC}	VREFAC Sink/Source Current			± 1.5	mA
T _A	Operating Temperature Range			-40 to +85	°C
T _{stg}	Storage Temperature Range			-65 to +150	°C
θ _{JA}	Thermal Resistance (Junction-to-Ambient) (Note 4)	0 lfpm 500 lfpm	QFN-16 QFN-16	42 35	°C/W
θ _{JC}	Thermal Resistance (Junction-to-Case) (Note 4)		QFN-16	4	°C/W
T _{sol}	Wave Solder Pb-Free			265	°C

Stresses exceeding Maximum Ratings may damage the device. Maximum Ratings are stress ratings only. Functional operation above the Recommended Operating Conditions is not implied. Extended exposure to stresses above the Recommended Operating Conditions may affect device reliability.

4. JEDEC standard multilayer board – 2S2P (2 signal, 2 power) with 8 filled thermal vias under exposed pad.

NB7V33M

Table 5. DC CHARACTERISTICS POSITIVE CML OUTPUT $V_{CC} = 1.71\text{ V to }2.625\text{ V}$; $GND = 0\text{ V}$; $T_A = -40^\circ\text{C to }85^\circ\text{C}$ (Note 5)

Symbol	Characteristic	Min	Typ	Max	Unit
POWER SUPPLY CURRENT					
I_{CC}	Power Supply Current (Inputs and Outputs Open) $V_{CC} = 2.5\text{ V} \pm 5\%$ $V_{CC} = 1.8\text{ V} \pm 5\%$		95 85	115 100	mA
CML OUTPUTS					
V_{OH}	Output HIGH Voltage (Note 6) $V_{CC} = 2.5\text{ V}$ $V_{CC} = 1.8\text{ V}$	$V_{CC} - 30$ 2470 1770	$V_{CC} - 10$ 2490 1790	V_{CC} 2500 1800	mV
V_{OL}	Output LOW Voltage (Note 6) $V_{CC} = 2.5\text{ V}$ $V_{CC} = 1.8\text{ V}$	$V_{CC} - 650$ 1850 $V_{CC} - 600$ 1200	$V_{CC} - 550$ 1950 $V_{CC} - 500$ 1300	$V_{CC} - 450$ 2050 $V_{CC} - 400$ 1400	mV
DIFFERENTIAL INPUTS DRIVEN SINGLE-ENDED (Note 7) (Figures 5 & 6)					
V_{th}	Input Threshold Reference Voltage Range (Note 8)	1050		$V_{CC} - 100$	mV
V_{IH}	Single-ended Input HIGH Voltage	$V_{th} + 100$		V_{CC}	mV
V_{IL}	Single-ended Input LOW Voltage	GND		$V_{th} - 100$	mV
V_{ISE}	Single-ended Input Voltage ($V_{IH} - V_{IL}$)	200		1200	mV
VREFAC					
V_{REFAC}	Output Reference Voltage @100 μA for Capacitor- Coupled Inputs, Only $V_{CC} = 2.5\text{ V}$ $V_{CC} = 1.8\text{ V}$	$V_{CC} - 850$ $V_{CC} - 750$		$V_{CC} - 500$ $V_{CC} - 450$	mV
DIFFERENTIAL INPUTS DRIVEN DIFFERENTIALLY (Figures 7 & 8) (Note 9)					
V_{IHD}	Differential Input HIGH Voltage	1100		V_{CC}	mV
V_{ILD}	Differential Input LOW Voltage	GND		$V_{CC} - 100$	mV
V_{ID}	Differential Input Voltage ($V_{IHD} - V_{ILD}$)	100		1200	mV
V_{CMR}	Input Common Mode Range (Differential Configuration, Note 10) (Figure 9)	1050		$V_{CC} - 50$	mV
I_{IH}	Input HIGH Current ($V_{TX}/\sqrt{T_X}$ Open)	-150		150	μA
I_{IL}	Input LOW Current ($V_{TX}/\sqrt{T_X}$ Open)	-150		150	μA
CONTROL INPUT (Reset pin)					
V_{IH}	Input HIGH Voltage for Control Pin	$V_{CC} - 200$		V_{CC}	mV
V_{IL}	Input LOW Voltage for Control Pin	GND		200	mV
I_{IH}	Input HIGH Current	-150		150	μA
I_{IL}	Input LOW Current	-150		150	μA
TERMINATION RESISTORS					
R_{TIN}	Internal Input Termination Resistor	45	50	55	Ω
R_{TOUT}	Internal Output Termination Resistor	45	50	55	Ω

NOTE: Device will meet the specifications after thermal equilibrium has been established when mounted in a test socket or printed circuit board with maintained transverse airflow greater than 500 lpm. Electrical parameters are guaranteed only over the declared operating temperature range. Functional operation of the device exceeding these conditions is not implied. Device specification limit values are applied individually under normal operating conditions and not valid simultaneously.

5. Input and output parameters vary 1:1 with V_{CC} .
6. CML outputs loaded with $50\text{-}\Omega$ to V_{CC} for proper operation.
7. V_{th} , V_{IH} , V_{IL} , and V_{ISE} parameters must be complied with simultaneously.
8. V_{th} is applied to the complementary input when operating in single-ended mode.
9. V_{IHD} , V_{ILD} , V_{ID} and V_{CMR} parameters must be complied with simultaneously.
10. V_{CMR} min varies 1:1 with GND, V_{CMR} max varies 1:1 with V_{CC} . The V_{CMR} range is referenced to the most positive side of the differential input signal.

NB7V33M

Table 6. AC CHARACTERISTICS $V_{CC} = 1.71\text{ V to }2.625\text{ V}$; $GND = 0\text{ V}$; $T_A = -40^\circ\text{C to }85^\circ\text{C}$ (Note 11)

Symbol	Characteristic	Min	Typ	Max	Unit	
f_{MAX}	Maximum Input Clock Frequency	10	11		GHz	
V_{OUTPP}	Output Voltage Amplitude (@ $V_{INPPmin}$) $f_{in} \leq 10\text{ GHz}$ (Note 12) (Figure 3)	260	400		mV	
t_{PLH} , t_{PHL}	Propagation Delay to Differential Outputs, @ 1 GHz, measured at differential crosspoint	CLK/ \overline{CLK} to Q, \overline{Q} R to Q, \overline{Q}	150 500	200 600	350 700	ps
$t_{PLH\ TC}$	Propagation Delay Temperature Coefficient		50		$\Delta fs/^\circ C$	
t_{skew}	Duty Cycle Skew (Note 13) Device – Device skew ($tpdmax - tpdmin$)			20 50	ps	
t_{RR}	Reset Recovery (See Figure 16)	550	135		ps	
t_{PW}	Minimum Pulse Width R	500	200		ps	
t_{DC}	Output Clock Duty Cycle (Reference Duty Cycle = 50%) $f_{in} \leq 10\text{ GHz}$	45	50	55	%	
ϕ_N	Phase Noise, $f_c = 1\text{ GHz}$		10 kHz 100 kHz 1 MHz 10 MHz 20 MHz 40 MHz	-144 -147 -152 -152 -152 -153	dBc	
$t_{j\phi N}$	Integrated Phase Jitter (Figure x) $f_c = 1\text{ GHz}$, 12 kHz – 20 MHz Offset		35		fs	
t_{JITTER}	RJ – Output Random Jitter (Note 14) $f_{in} \leq 10.0\text{ GHz}$		0.2	0.8	ps RMS	
V_{INPP}	Input Voltage Swing (Differential Configuration) (Figure 11) (Note 15)	200		1200	mV	
t_r , t_f	Output Rise/Fall Times @ 1 GHz (20% – 80%), Q, \overline{Q}	20	35	60	ps	

NOTE: Device will meet the specifications after thermal equilibrium has been established when mounted in a test socket or printed circuit board with maintained transverse airflow greater than 500 lfm. Electrical parameters are guaranteed only over the declared operating temperature range. Functional operation of the device exceeding these conditions is not implied. Device specification limit values are applied individually under normal operating conditions and not valid simultaneously.

11. Measured using a 1 GHz, $V_{INPPmin}$, 50% duty-cycle clock source. All output loading with external 50 Ω to V_{CC} . Input edge rates 40 ps (20% – 80%).
12. Output voltage swing is a single-ended measurement operating in differential mode.
13. Duty cycle skew is defined only for differential operation when the delays are measured from cross-point of the inputs to the cross-point of the outputs. Duty cycle skew is measured between differential outputs using the deviations of the sum of T_{pw-} and T_{pw+} @ 1 GHz. Skew is measured between outputs under identical transitions and conditions.
14. Additive RMS jitter with 50% duty cycle clock signal.
15. Input voltage swing is a single-ended measurement operating in differential mode.

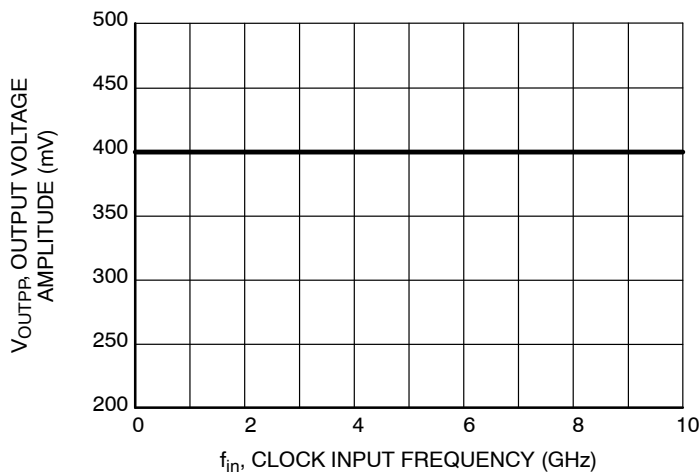

Figure 3. Output Voltage Amplitude (V_{OUTPP}) vs. Input Frequency (f_{in}) at Ambient Temperature (Typical)

NB7V33M

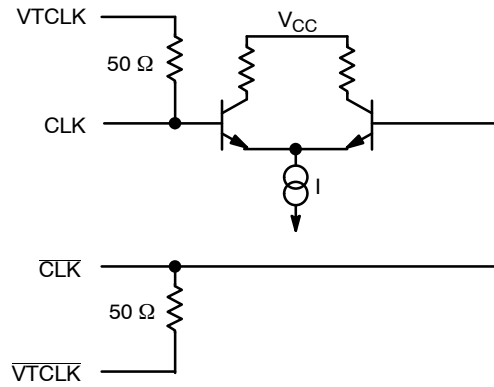

Figure 4. Input Structure

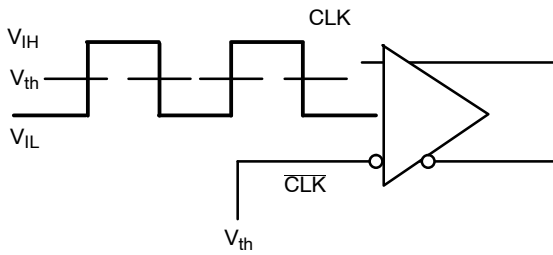

Figure 5. Differential Input Driven Single-Ended

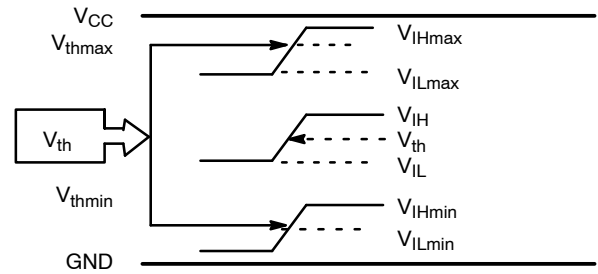

Figure 6. V_{th} Diagram

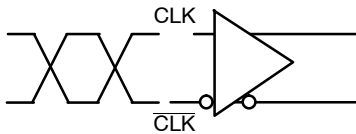

Figure 7. Differential Inputs Driven Differentially

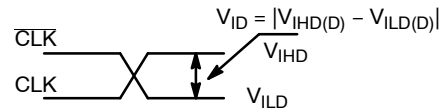

Figure 8. Differential Inputs Driven Differentially

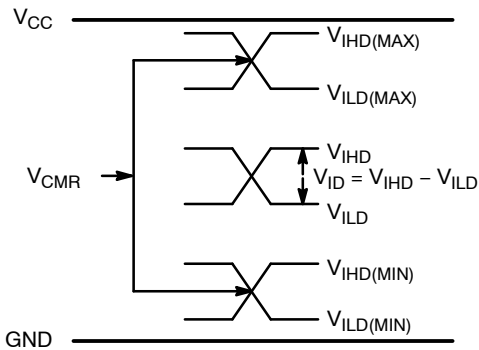

Figure 9. V_{CMR} Diagram

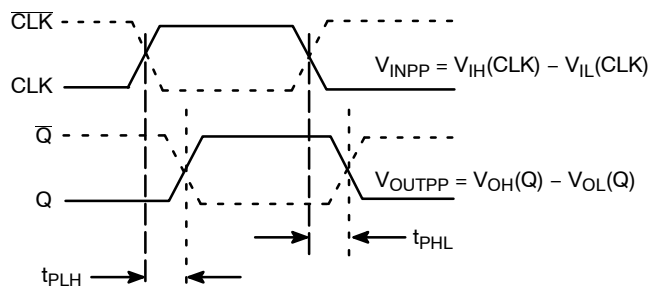

Figure 10. AC Reference Measurement

NB7V33M

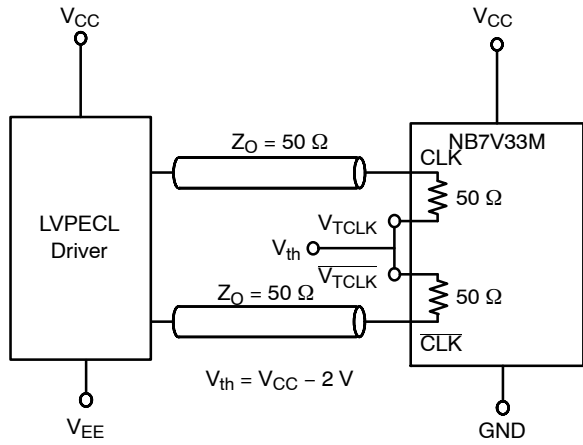

Figure 11. LVPECL Interface

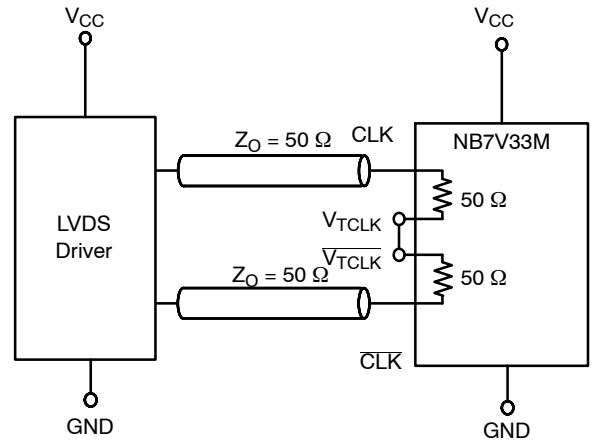

Figure 12. LVDS Interface

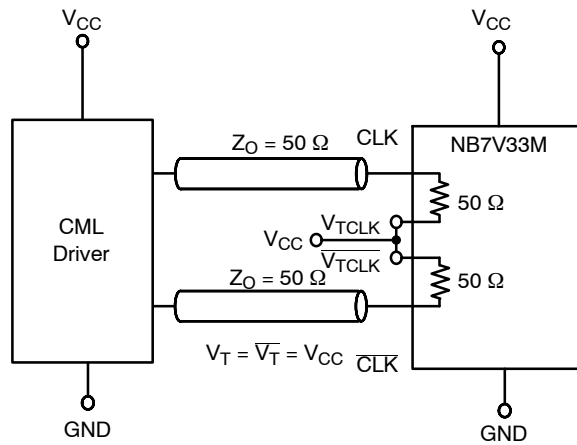

Figure 13. Standard 50 Ω Load CML Interface

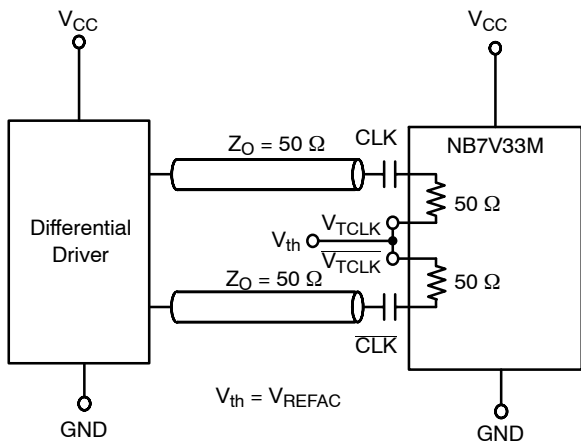

Figure 14. Capacitor-Coupled Differential Interface ($V_{TCLK}/\sqrt{V_{TCLK}}$ Connected to V_{REFAC} ; V_{REFAC} Bypassed to Ground with 0.1 μ F Capacitor)

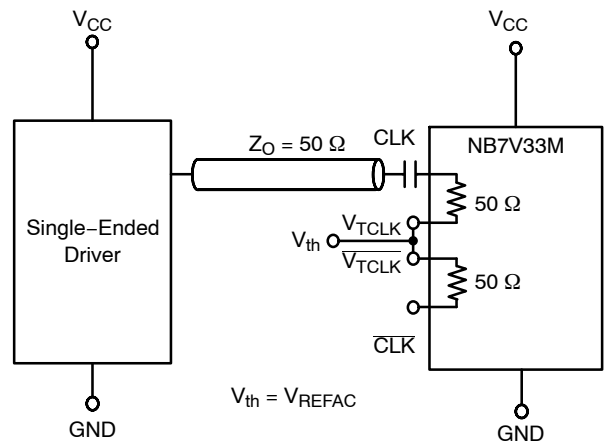

Figure 15. Capacitor-Coupled Single-Ended Interface ($V_{TCLK}/\sqrt{V_{TCLK}}$ Connected to V_{REFAC} ; V_{REFAC} Bypassed to Ground with 0.1 μ F Capacitor)

NB7V33M

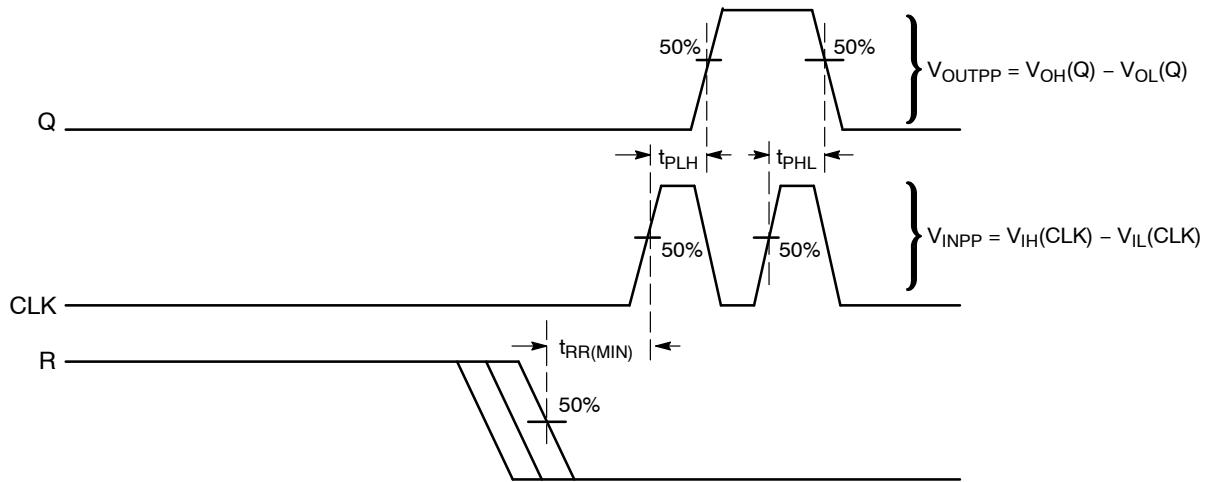

Figure 16. AC Reference Measurement (Timing Diagram)

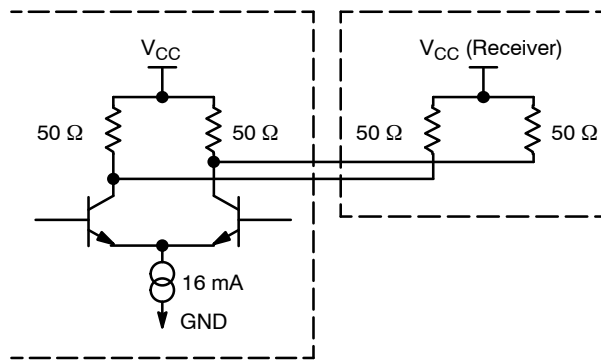

Figure 17. Typical CML Output Structure and Termination

NB7V33M

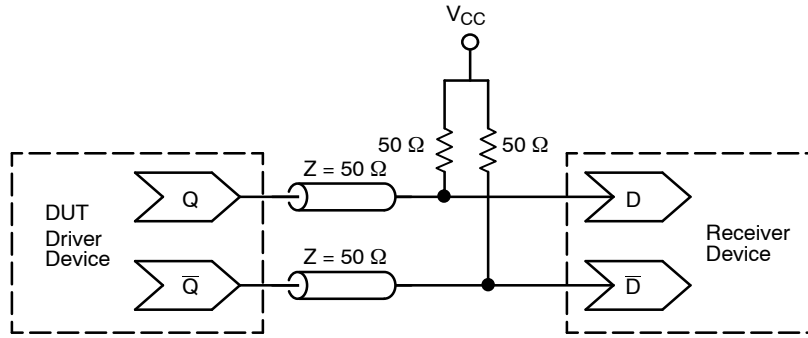

Figure 18. Typical Termination for CML Output Driver and Device Evaluation

DEVICE ORDERING INFORMATION¹

Device	Package	Shipping [†]
NB7V33MMNG	QFN-16 (Pb-Free)	123 Units / Rail
NB7V33MMNHTBG	QFN-16 (Pb-Free)	100 / Tape & Reel
NB7V33MMNTXG	QFN-16 (Pb-Free)	3000 / Tape & Reel

[†]For information on tape and reel specifications, including part orientation and tape sizes, please refer to our Tape and Reel Packaging Specifications Brochure, BRD8011/D.

NB7V33M

PACKAGE DIMENSIONS

16 PIN QFN
CASE 485G-01
ISSUE D

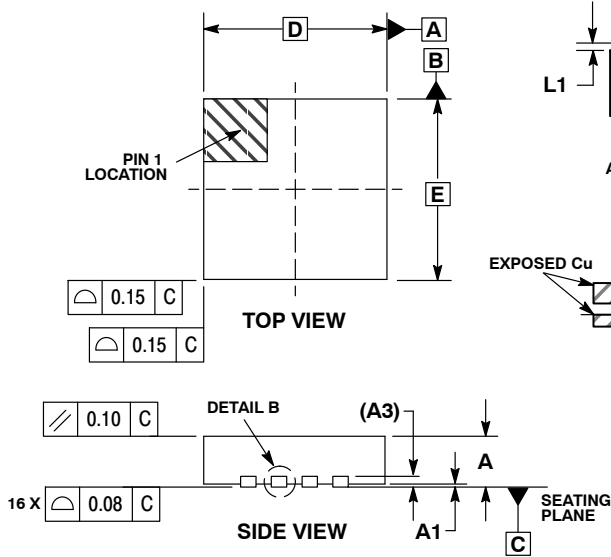

NOTES:

1. DIMENSIONING AND TOLERANCING PER ASME Y14.5M, 1994.
2. CONTROLLING DIMENSION: MILLIMETERS.
3. DIMENSION b APPLIES TO PLATED TERMINAL AND IS MEASURED BETWEEN 0.25 AND 0.30 MM FROM TERMINAL.
4. COPLANARITY APPLIES TO THE EXPOSED PAD AS WELL AS THE TERMINALS.
5. L_{max} CONDITION CAN NOT VIOLATE 0.2 MM MINIMUM SPACING BETWEEN LEAD TIP AND FLAG

DIM	MILLIMETERS	
	MIN	MAX
A	0.80	1.00
A1	0.00	0.05
A3	0.20 REF	
b	0.18	0.30
D	3.00 BSC	
D2	1.65	1.85
E	3.00 BSC	
E2	1.65	1.85
e	0.50 BSC	
K	0.18 TYP	
L	0.30	0.50
L1	0.00	0.15

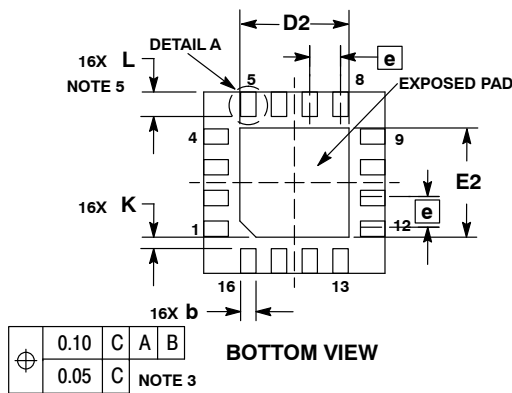

SOLDERING FOOTPRINT*

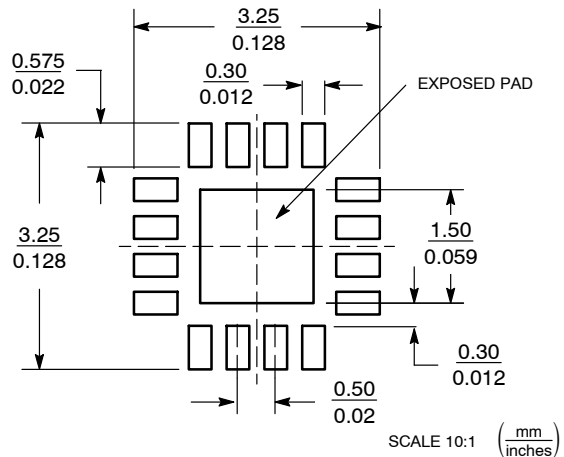

*For additional information on our Pb-Free strategy and soldering details, please download the ON Semiconductor Soldering and Mounting Techniques Reference Manual, SOLDERRM/D.

The products described herein (NB7V33M), may be covered by U.S. patents including 6,362,644. There may be other patents pending. GigaComm is a trademark of Semiconductor Component Industries, LLC (SCILLC).

ON Semiconductor and are registered trademarks of Semiconductor Components Industries, LLC (SCILLC). SCILLC reserves the right to make changes without further notice to any products herein. SCILLC makes no warranty, representation or guarantee regarding the suitability of its products for any particular purpose, nor does SCILLC assume any liability arising out of the application or use of any product or circuit, and specifically disclaims any and all liability, including without limitation special, consequential or incidental damages. "Typical" parameters which may be provided in SCILLC data sheets and/or specifications can and do vary in different applications and actual performance may vary over time. All operating parameters, including "Typicals" must be validated for each customer application by customer's technical experts. SCILLC does not convey any license under its patent rights nor the rights of others. SCILLC products are not designed, intended, or authorized for use as components in systems intended for surgical implant into the body, or other applications intended to support or sustain life, or for any other application in which the failure of the SCILLC product could create a situation where personal injury or death may occur. Should Buyer purchase or use SCILLC products for any such unintended or unauthorized application, Buyer shall indemnify and hold SCILLC and its officers, employees, subsidiaries, affiliates, and distributors harmless against all claims, costs, damages, and expenses, and reasonable attorney fees arising out of, directly or indirectly, any claim of personal injury or death associated with such unintended or unauthorized use, even if such claim alleges that SCILLC was negligent regarding the design or manufacture of the part. SCILLC is an Equal Opportunity/Affirmative Action Employer. This literature is subject to all applicable copyright laws and is not for resale in any manner.

PUBLICATION ORDERING INFORMATION

LITERATURE FULFILLMENT:
Literature Distribution Center for ON Semiconductor
P.O. Box 5163, Denver, Colorado 80217 USA
Phone: 303-675-2175 or 800-344-3860 Toll Free USA/Canada
Fax: 303-675-2176 or 800-344-3867 Toll Free USA/Canada
Email: orderlit@onsemi.com

N. American Technical Support: 800-282-9855 Toll Free USA/Canada
Europe, Middle East and Africa Technical Support:
Phone: 421 33 790 2910
Japan Customer Focus Center
Phone: 81-3-5773-3850

ON Semiconductor Website: www.onsemi.com
Order Literature: <http://www.onsemi.com/orderlit>
For additional information, please contact your local Sales Representative