

NB3N853531E

3.3 V Xtal or LVTTL/LVCMOS Input 2:1 MUX to 1:4 LVPECL Fanout Buffer

Description

The NB3N853531E is a low skew 3.3 V supply 1:4 clock distribution fanout buffer. An input MUX selects either a Fundamental Parallel Mode Crystal or a LVCMOS/LVTTL Clock by using the CLK_SEL pin (HIGH for Crystal, LOW for Clock) with LVCMOS / LVTTL levels.

The single ended CLK input is translated to four LVPECL Outputs. Using the crystal input, the NB3N853531E can be a Clock Generator. A CLK_EN pin can enable or disable the outputs synchronously to eliminate runt pulses using LVCMOS/LVTTL levels (HIGH to enable outputs, LOW to disable outputs).

Features

- Four Differential 3.3 V LVPECL Outputs
- Selectable Crystal or LVCMOS/LVTTL CLOCK Inputs
- Up to 266 MHz Clock Operation
- Output to Output Skew: 30 ps (Max)
- Device to Device Skew 200 ps (Max)
- Propagation Delay 1.8 ns (Max)
- Operating Range: $V_{CC} = 3.3 \pm 5\% V$ (3.135 to 3.465 V)
- Additive Phase Jitter, RMS: 0.053 ps (Typ)
- Synchronous Clock Enable Control
- Industrial Temp. Range (-40°C to 85°C)
- Pb-Free TSSOP-20 Package
- Ambient Operating Temperature Range -40°C to +85°C
- These are Pb-Free Devices



ON Semiconductor®

<http://onsemi.com>

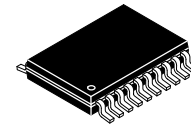

TSSOP-20
DT SUFFIX
CASE 948E

MARKING DIAGRAM

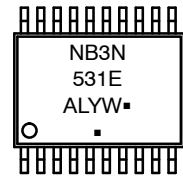

- A = Assembly Location
- L = Wafer Lot
- Y = Year
- W = Work Week
- = Pb-Free Package

(Note: Microdot may be in either location)

ORDERING INFORMATION

See detailed ordering and shipping information in the package dimensions section on page 7 of this data sheet.

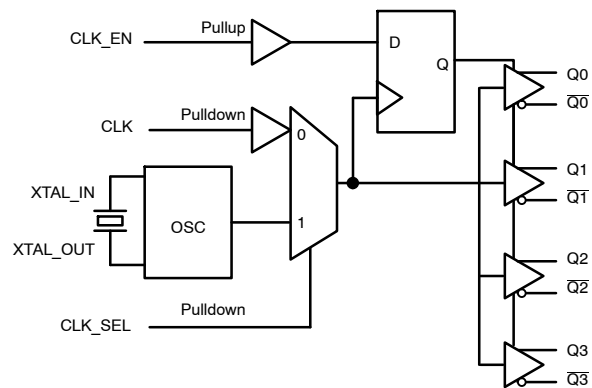

Figure 1. Simplified Logic Diagram

NB3N853531E

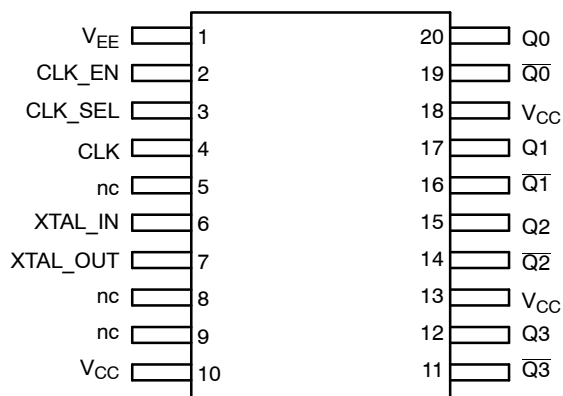

Figure 2. Pinout Diagram (Top View)

Table 1. PIN DESCRIPTION

Pin	Name	I/O	Open Default	Description
1	V _{EE}			Negative (Ground) Power Supply pin must be externally connected to power supply to guarantee proper operation.
2	CLK_EN	LVC MOS / LV TTL	Pullup	Synchronized Clock Enable when HIGH. When LOW, outputs are disabled (Qx HIGH, Q _x LOW)
3	CLK_SEL	LVC MOS / LV TTL	Pulldown	Clock Input Select (HIGH selects crystal, LOW selects CLK input)
4	CLK	LVC MOS / LV TTL	Pulldown	Clock Input. Float open when unused.
5, 8, 9	nc			No Connect
6	XTAL_IN	Crystal		Crystal Oscillator Input (used with pin 7). Float open when unused.
7	XTAL_OUT	Crystal		Crystal Oscillator Output (used with pin 6). Float open when unused.
10, 13, 18	V _{CC}			Positive Power Supply pins must be externally connected to power supply to guarantee proper operation.
11, 14, 16, 19	Q[3:0]	LVPECL		Complement Differential Outputs (See AND8020 for termination)
12, 15, 17, 20	Q[3:0]	LVPECL		True Differential Outputs (See AND8020 for termination)

Table 2. FUNCTIONS

Inputs			Outputs		
CLK_EN	CLK_SEL	Input Function	Output Function	Q _x	Q _x
0	0	CLK input selected	Disabled	LOW	HIGH
0	1	Crystal Inputs Selected	Disabled	LOW	HIGH
1	0	CLK input selected	Enabled	CLK0	Invert of CLK1
1	1	Crystal Inputs Selected	Enabled	CLK1	Invert of CLK1

1. After CLK_EN switches, the clock outputs are disabled or enabled following a rising and falling input clock edge as show in Figure 3.

NB3N853531E

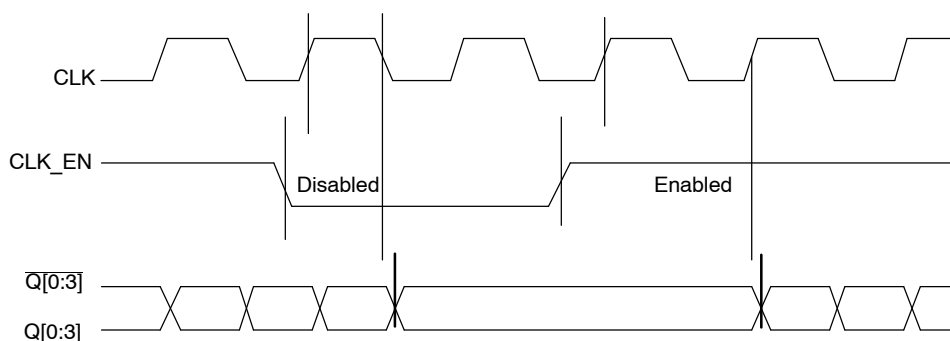

Figure 3. CLK_EN Timing Diagram

Table 3. ATTRIBUTES (Note 2)

Characteristics	Value
Internal Input Pullup Resistor	50 kΩ
Internal Input Pulldown Resistor	50 kΩ
C _{in} Input Capacitance	4 pF
ESD Protection	Human Body Model Machine Model
	> 2 kV > 200 V
Moisture Sensitivity, Indefinite Time Out of Drypack (Note 2)	Level 1
Flammability Rating Oxygen Index	UL 94 V-0 @ 0.125 in 28 to 34
Transistor Count	333 Devices
Meets or exceeds JEDEC Spec EIA/JESD78 IC Latchup Test	

2. For additional information, see Application Note AND8003/D.

Table 4. MAXIMUM RATINGS (Note 3)

Symbol	Parameter	Condition 1	Condition 2	Rating	Unit
V _{CC}	Supply Voltage			4.6	V
V _{in}	Input Voltage			-0.5 ≤ V _I ≤ V _{CC} + 0.5	V
I _{out}	Output Current	Continuous Surge		50 100	mA
T _A	Operating Temperature Range, Industrial			-40 to ≤ +85	°C
T _{stg}	Storage Temperature Range			-65 to +150	°C
θ _{JA}	Thermal Resistance (Junction-to-Ambient)	0 lfpm	Single-Layer PCB (700 mm ² , 2 oz)	128	°C/W
		200 lfpm	Multi-Layer PCB (700 mm ² , 2 oz)	94	
θ _{JC}	Thermal Resistance (Junction-to-Case)	(Note 4)	TSSOP-20	23 to 41	°C/W
T _{sol}	Wave Solder			265	°C

Stresses exceeding Maximum Ratings may damage the device. Maximum Ratings are stress ratings only. Functional operation above the Recommended Operating Conditions is not implied. Extended exposure to stresses above the Recommended Operating Conditions may affect device reliability.

3. Maximum ratings applied to the device are individual stress limit values (not normal operating conditions) and not valid simultaneously.

If stress limits are exceeded device functional operation is not implied, damage may occur and reliability may be affected.

4. JEDEC standard multilayer board – 2S2P (2 signal, 2 power).

Table 5. CRYSTAL CHARACTERISTICS AND CONNECTIONS

Parameter	Min	Typ	Max	Unit
Mode of Oscillation	Fundamental Parallel			
Frequency	12		40	MHz
Equivalent Series Resistance (ESR)			50	Ω
Shunt Capacitance			7	pF
Drive Level			1	mW

Table 6. DC CHARACTERISTICS $V_{CC} = 3.3 \pm 5\% V$ (3.135 to 3.465 V), $V_{EE} = 0 V$, $T_A = -40^\circ C$ to $+85^\circ C$ (Note 5)

Symbol	Characteristic	Min	Typ	Max	Unit
I_{EE}	Power Supply Current			60	mA
V_{IH}	Input HIGH Voltage	2		$V_{CC} + 0.3$	V
V_{IL}	Input LOW Voltage	-0.3		0.8	V
I_{IH}	Input High Current ($V_{CC} = 3.456 V$) CLK, CLK_SEL = 3.456 V CLK_EN = 3.456 V			150 5	μA
I_{IL}	Input LOW Current ($V_{CC} = 3.456 V$) CLK, CLK_SEL = 3.456 V CLK_EN = 3.456 V	-5 -150			μA
V_{OH}	Output HIGH Voltage	$V_{CC} - 1.4$		$V_{CC} - 0.9$	V
V_{OL}	Output LOW Voltage	$V_{CC} - 2.0$		$V_{CC} - 1.7$	V
V_{OUT_SWING}	Output Voltage Swing (peak-to-peak)	0.6		1.0	V

NOTE: Device will meet the specifications after thermal equilibrium has been established when mounted in a test socket or printed circuit board with maintained transverse airflow greater than 500 lfm. Electrical parameters are guaranteed only over the declared operating temperature range. Functional operation of the device exceeding these conditions is not implied. Device specification limit values are applied individually under normal operating conditions and not valid simultaneously.

5. Outputs terminated 50 Ω to $V_{CC} - 2.0 V$, see Figure 4.

Table 7. AC CHARACTERISTICS $V_{CC} = 3.3 \pm 5\% V$ (3.135 to 3.465 V), $V_{EE} = 0 V$, $T_A = -40^\circ C$ to $+85^\circ C$ (Note 6)

Symbol	Characteristic	Min	Typ	Max	Unit
F_{MAX}	Maximum Operating Frequency	0		266	MHz
t_{PD}	Propagation Delay (Notes 7 and 9)	1.1		1.8	ns
$t_{SKEW_{DC}}$	Duty Cycle Skew same path similar conditions at 50 MHz (Notes 7, 8 and 9)	46		54	%
$t_{SKEW_{O-O}}$	Output to Output Skew Within A Device (Notes 7, 8 and 9)			30	ps
$t_{SKEW_{D-D}}$	Device to Device Skew similar path and conditions (Notes 7, 8 and 9)			200	ps
t_{JIT}	Additive Phase Noise Jitter (RMS) @ 155.52 MHz (Integrated from 12 kHz to 20 MHz) See Figure 6. (Note 9)		0.053		ps
t_r/t_f	Output rise and fall times (20% and 80% points) (Note 9)	225		600	ps

NOTE: Device will meet the specifications after thermal equilibrium has been established when mounted in a test socket or printed circuit board with maintained transverse airflow greater than 500 lfm. Electrical parameters are guaranteed only over the declared operating temperature range. Functional operation of the device exceeding these conditions is not implied. Device specification limit values are applied individually under normal operating conditions and not valid simultaneously.

6. Outputs terminated 50 Ω to $V_{CC} - 2.0 V$, see Figure 4.

7. Measured under the same supply voltage, output loading, and input conditions.

8. Similar conditions.

9. Limits do not apply to overdriving XTAL_IN.

NB3N853531E

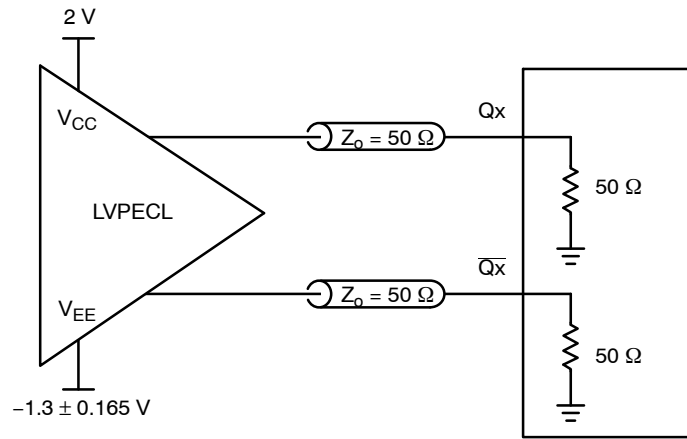

Figure 4. Typical Test Setup and Termination for Evaluation. A split supply of $V_{CC} = 2.0\text{ V}$ and $V_{EE} = -1.3 \pm 0.165\text{ V}$ allows a convenient direct connection termination into typical oscilloscope $50\ \Omega$ to GND impedance modules. For Application termination schemes see AND8020.

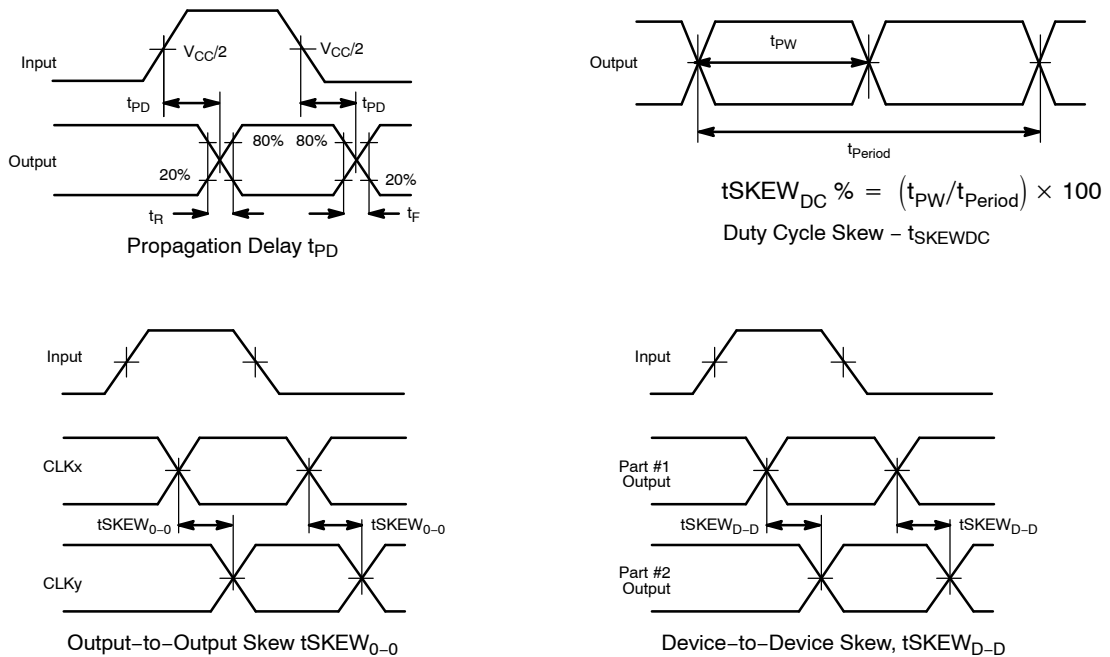

Figure 5. AC Measurement Reference

NB3N853531E

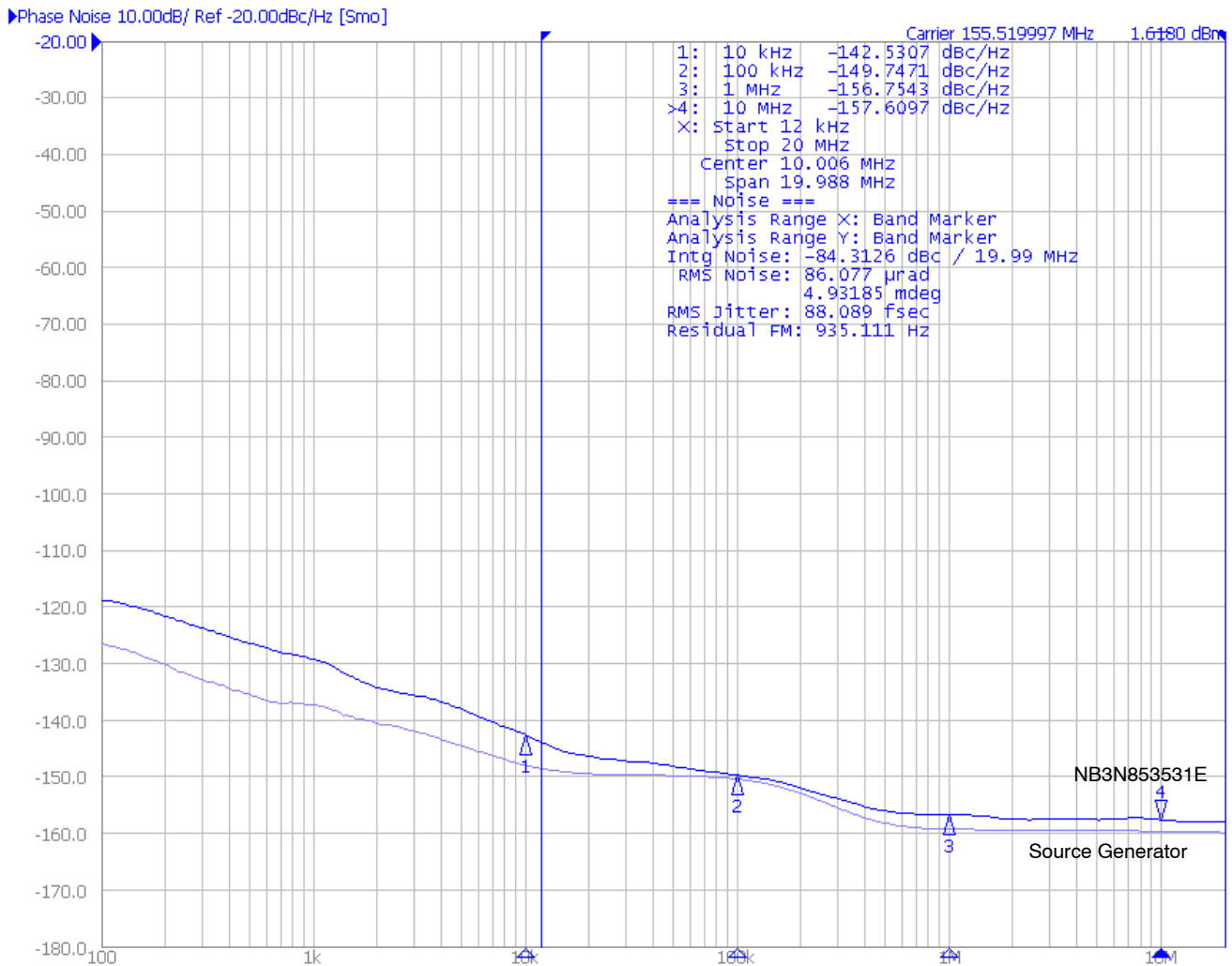

Figure 6. For 155.52 MHz Carrier, the NB3N853531E Additive Phase Noise (dBc/Hz) versus SSB Offset Frequency (Hz) Integrated Jitter from 12 kHz to 20 MHz (Upper Heavy Line) is 88.1 fs RMS. The E8663B Source Generator Additive Phase Noise (Lower Light Line) is 70.1 fs RMS. Where $t_{JIT} = \sqrt{(t_{JIToutput})^2 - (t_{JITinput})^2} = 53$ fs

Application – Crystal Input Interface

Figure 7 shows the NB3N853531E device crystal oscillator interface using a typical parallel resonant crystal. A parallel crystal with loading capacitance $C_L = 18$ pF could use Series Load Caps $C1 = 32$ pF and $C2 = 32$ pF as nominal values, after subtracting a typical 4 pF of stray cap per line. The frequency accuracy and duty cycle skew can be fine tuned by adjusting the C1 and C2 values. For example, increasing the C1 and C2 values will reduce the operational frequency. Note R1 is optional and may be 0 Ω.

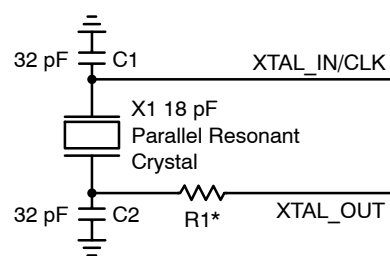

Figure 7. NB3N853531E Crystal Oscillator Interface
 *R1 is optional. Assuming 4 pF stray cap per pin.

NB3N853531E

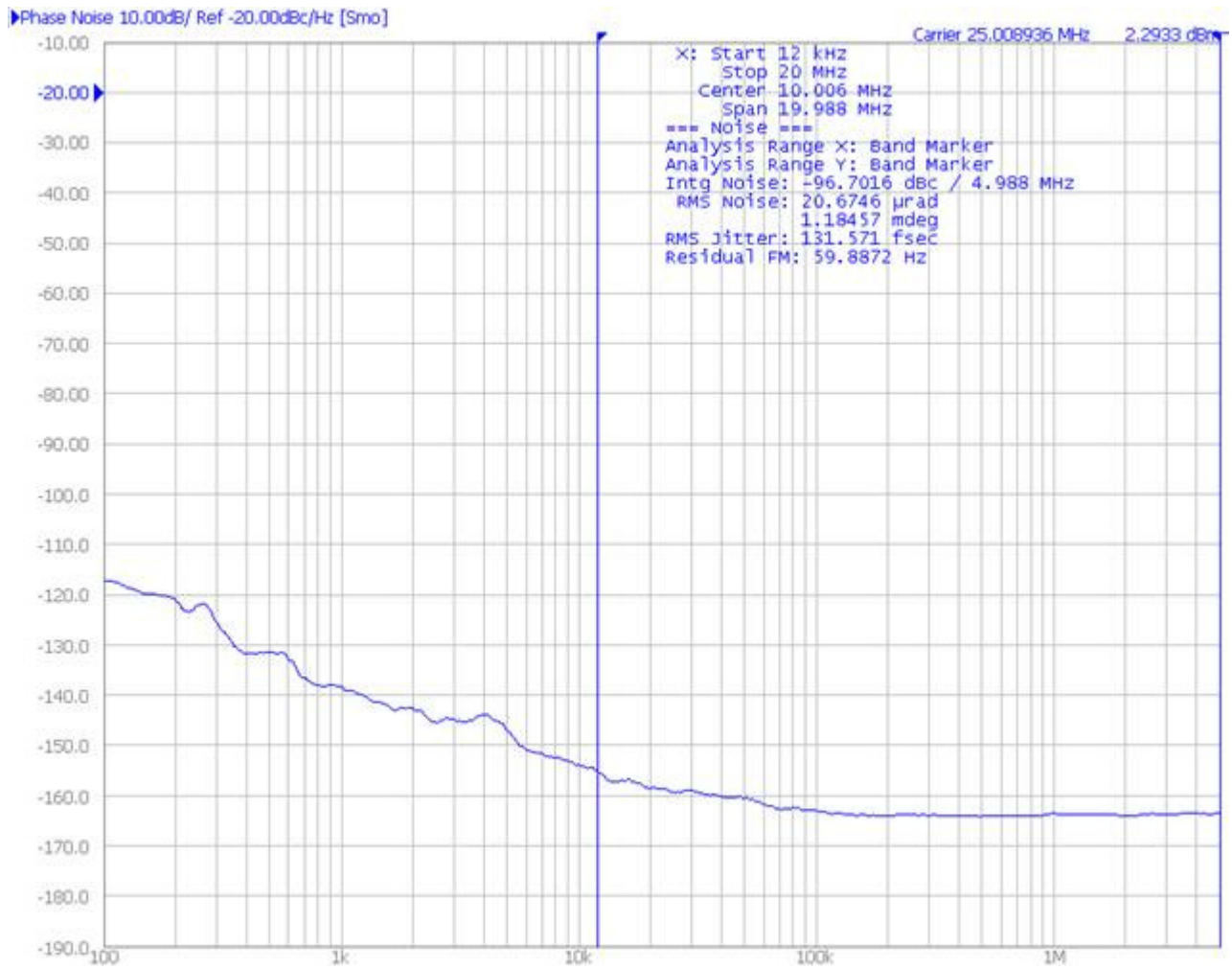

Figure 8. NB3N853531E Phase Noise with 25 MHz Crystal

ORDERING INFORMATION

Device	Package	Shipping†
NB3N853531EDTG	TSSOP-20 (Pb-Free)	75 Units / Rail
NB3N853531EDTR2G	TSSOP-20 (Pb-Free)	2500 / Tape & Reel

†For information on tape and reel specifications, including part orientation and tape sizes, please refer to our Tape and Reel Packaging Specifications Brochure, BRD8011/D.

NB3N853531E

PACKAGE DIMENSIONS

TSSOP-20
CASE 948E-02
ISSUE C

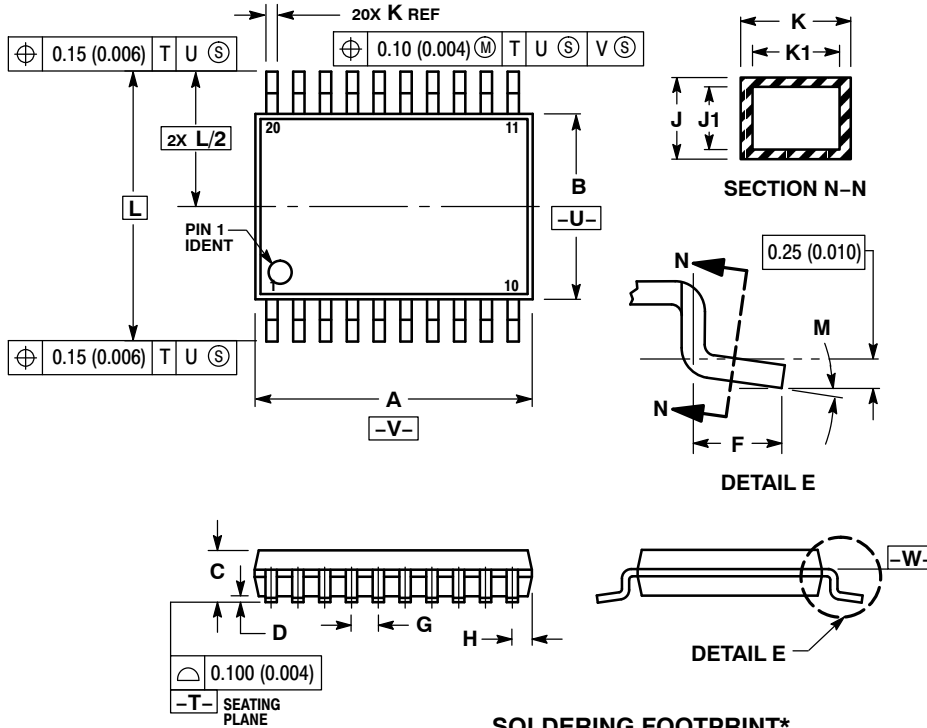

NOTES:

1. DIMENSIONING AND TOLERANCING PER ANSI Y14.5M, 1982.
2. CONTROLLING DIMENSION: MILLIMETER.
3. DIMENSION A DOES NOT INCLUDE MOLD FLASH, PROTRUSIONS OR GATE BURRS. MOLD FLASH OR GATE BURRS SHALL NOT EXCEED 0.15 (0.006) PER SIDE.
4. DIMENSION B DOES NOT INCLUDE INTERLEAD FLASH OR PROTRUSION. INTERLEAD FLASH OR PROTRUSION SHALL NOT EXCEED 0.25 (0.010) PER SIDE.
5. DIMENSION K DOES NOT INCLUDE DAMBAR PROTRUSION. ALLOWABLE DAMBAR PROTRUSION SHALL BE 0.08 (0.003) TOTAL IN EXCESS OF THE K DIMENSION AT MAXIMUM MATERIAL CONDITION.
6. TERMINAL NUMBERS ARE SHOWN FOR REFERENCE ONLY.
7. DIMENSION A AND B ARE TO BE DETERMINED AT DATUM PLANE -V-.

DIM	MILLIMETERS		INCHES	
	MIN	MAX	MIN	MAX
A	6.40	6.60	0.252	0.260
B	4.30	4.50	0.169	0.177
C	---	1.20	---	0.047
D	0.05	0.15	0.002	0.006
F	0.50	0.75	0.020	0.030
G	0.65 BSC		0.026 BSC	
H	0.27	0.37	0.011	0.015
J	0.09	0.20	0.004	0.008
J1	0.09	0.16	0.004	0.006
K	0.19	0.30	0.007	0.012
K1	0.19	0.25	0.007	0.010
L	6.40 BSC		0.252 BSC	
M	0°	8°	0°	8°

SOLDERING FOOTPRINT*

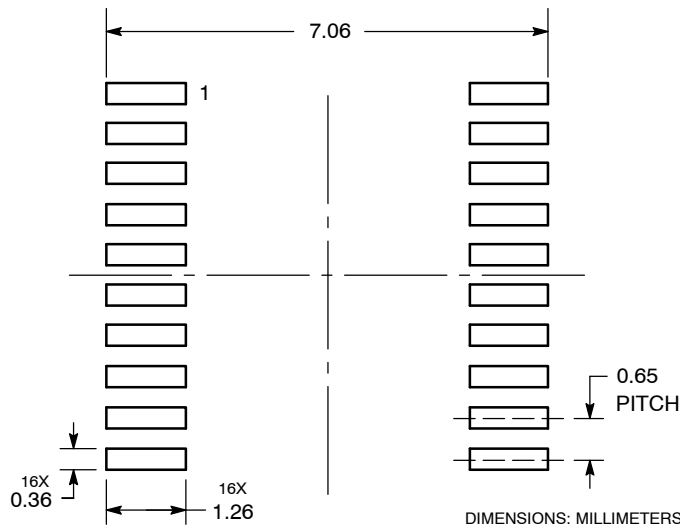

*For additional information on our Pb-Free strategy and soldering details, please download the ON Semiconductor Soldering and Mounting Techniques Reference Manual, SOLDERRM/D.

ON Semiconductor and **ON** are registered trademarks of Semiconductor Components Industries, LLC (SCILLC). SCILLC reserves the right to make changes without further notice to any products herein. SCILLC makes no warranty, representation or guarantee regarding the suitability of its products for any particular purpose, nor does SCILLC assume any liability arising out of the application or use of any product or circuit, and specifically disclaims any and all liability, including without limitation special, consequential or incidental damages. "Typical" parameters which may be provided in SCILLC data sheets and/or specifications can and do vary in different applications and actual performance may vary over time. All operating parameters, including "Typicals" must be validated for each customer application by customer's technical experts. SCILLC does not convey any license under its patent rights nor the rights of others. SCILLC products are not designed, intended, or authorized for use as components in systems intended for surgical implant into the body, or other applications intended to support or sustain life, or for any other application in which the failure of the SCILLC product could create a situation where personal injury or death may occur. Should Buyer purchase or use SCILLC products for any such unintended or unauthorized application, Buyer shall indemnify and hold SCILLC and its officers, employees, subsidiaries, affiliates, and distributors harmless against all claims, costs, damages, and expenses, and reasonable attorney fees arising out of, directly or indirectly, any claim of personal injury or death associated with such unintended or unauthorized use, even if such claim alleges that SCILLC was negligent regarding the design or manufacture of the part. SCILLC is an Equal Opportunity/Affirmative Action Employer. This literature is subject to all applicable copyright laws and is not for resale in any manner.

PUBLICATION ORDERING INFORMATION

LITERATURE FULFILLMENT:

Literature Distribution Center for ON Semiconductor
P.O. Box 5163, Denver, Colorado 80217 USA
Phone: 303-675-2175 or 800-344-3860 Toll Free USA/Canada
Fax: 303-675-2176 or 800-344-3867 Toll Free USA/Canada
Email: orderlit@onsemi.com

N. American Technical Support: 800-282-9855 Toll Free
USA/Canada
Europe, Middle East and Africa Technical Support:
Phone: 421 33 790 2910
Japan Customer Focus Center
Phone: 81-3-5817-1050

ON Semiconductor Website: www.onsemi.com
Order Literature: <http://www.onsemi.com/orderlit>
For additional information, please contact your local
Sales Representative