

- **Low Supply Voltage Range 1.8 V to 3.6 V**
- **Ultralow-Power Consumption:**
 - Active Mode: 200 μ A at 1 MHz, 2.2 V
 - Standby Mode: 0.7 μ A
 - Off Mode (RAM Retention): 0.1 μ A
- **Five Power Saving Modes**
- **Wake-Up From Standby Mode in less than 6 μ s**
- **16-Bit RISC Architecture, 125 ns Instruction Cycle Time**
- **Basic Clock Module Configurations:**
 - Various Internal Resistors
 - Single External Resistor
 - 32 kHz Crystal
 - High Frequency Crystal
 - Resonator
 - External Clock Source
- **16-Bit Timer_A With Three Capture/Compare Registers**
- **On-Chip Comparator for Analog Signal Compare Function or Slope A/D Conversion**
- **Serial Communication Interface (USART0) Software-Selects Asynchronous UART or Synchronous SPI**
- **Serial Onboard Programming, No External Programming Voltage Needed Programmable Code Protection by Security Fuse**
- **Family Members Include:**
 - MSP430F122: 4KB + 256B Flash Memory
256B RAM
 - MSP430F123: 8KB + 256B Flash Memory
256B RAM
- **Available in a 28-Pin Plastic Small-Outline Wide Body (SOWB) Package, 28-Pin Plastic Thin Shrink Small-Outline Package (TSSOP) and 32-Pin QFN Package**
- **For Complete Module Descriptions, See the *MSP430x1xx Family User's Guide*, Literature Number SLAU049**

description

The Texas Instruments MSP430 family of ultralow power microcontrollers consist of several devices featuring different sets of peripherals targeted for various applications. The architecture, combined with five low power modes is optimized to achieve extended battery life in portable measurement applications. The device features a powerful 16-bit RISC CPU, 16-bit registers, and constant generators that attribute to maximum code efficiency. The digitally controlled oscillator (DCO) allows wake-up from low-power modes to active mode in less than 6 μ s.

The MSP430F12x series is an ultralow-power mixed signal microcontroller with a built-in 16-bit timer and twenty-two I/O pins. The MSP430F12x series also has a built-in communication capability using asynchronous (UART) and synchronous (SPI) protocols in addition to a versatile analog comparator.

Typical applications include sensor systems that capture analog signals, convert them to digital values, and then process the data and display them or transmit them to a host system. Stand alone RF sensor front end is another area of application. The I/O port inputs provide single slope A/D conversion capability on resistive sensors.

AVAILABLE OPTIONS

T _A	PACKAGED DEVICES		
	PLASTIC 28-PIN SOWB (DW)	PLASTIC 28-PIN TSSOP (PW)	PLASTIC 32-PIN QFN (RHB)
–40°C to 85°C	MSP430F122IDW MSP430F123IDW	MSP430F122IPW MSP430F123IPW	MSP430F122IRHB MSP430F123IRHB



Please be aware that an important notice concerning availability, standard warranty, and use in critical applications of Texas Instruments semiconductor products and disclaimers thereto appears at the end of this data sheet.

PRODUCTION DATA information is current as of publication date. Products conform to specifications per the terms of Texas Instruments standard warranty. Production processing does not necessarily include testing of all parameters.



POST OFFICE BOX 655303 • DALLAS, TEXAS 75265

Copyright © 2001 – 2004 Texas Instruments Incorporated

MSP430x12x MIXED SIGNAL MICROCONTROLLER

SLAS312C – JULY 2001 – REVISED SEPTEMBER 2004

pin designation, MSP430x12x

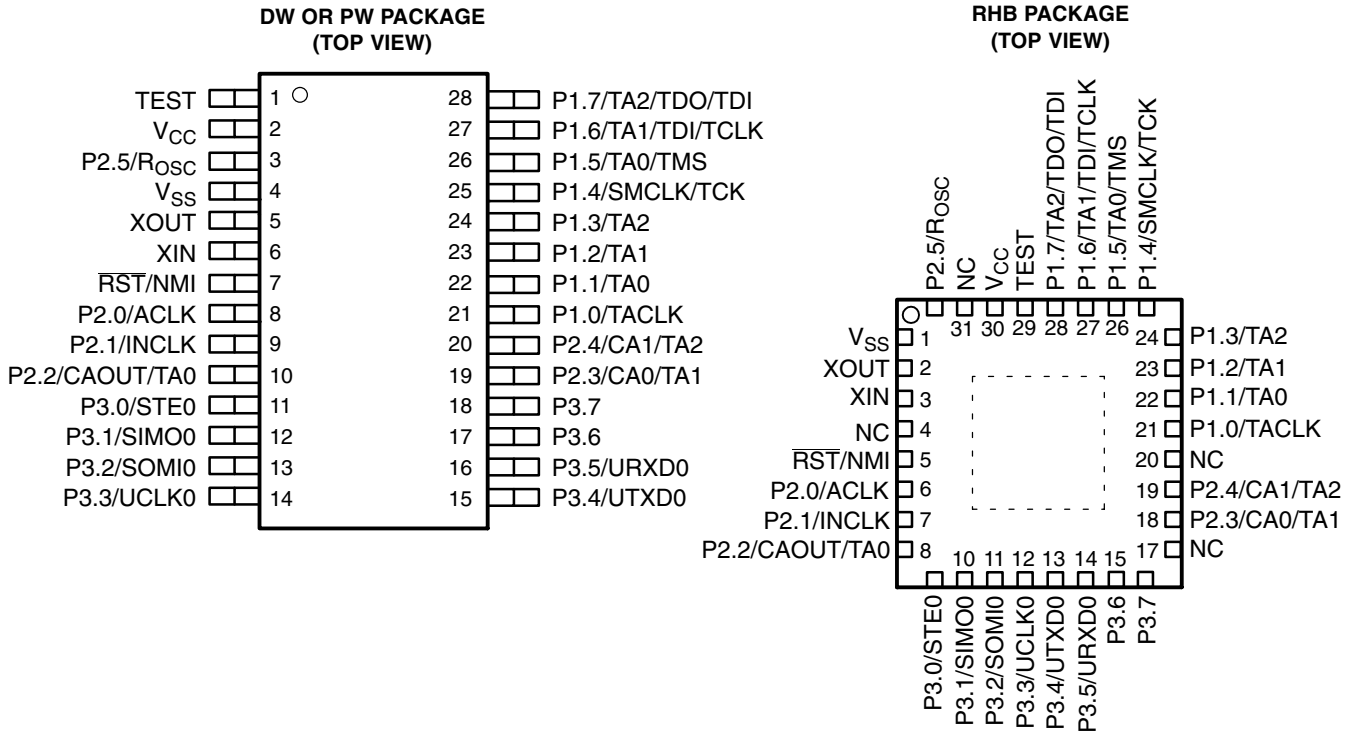

Note: NC pins not internally connected
Power Pad connection to V_{SS} recommended

functional block diagram

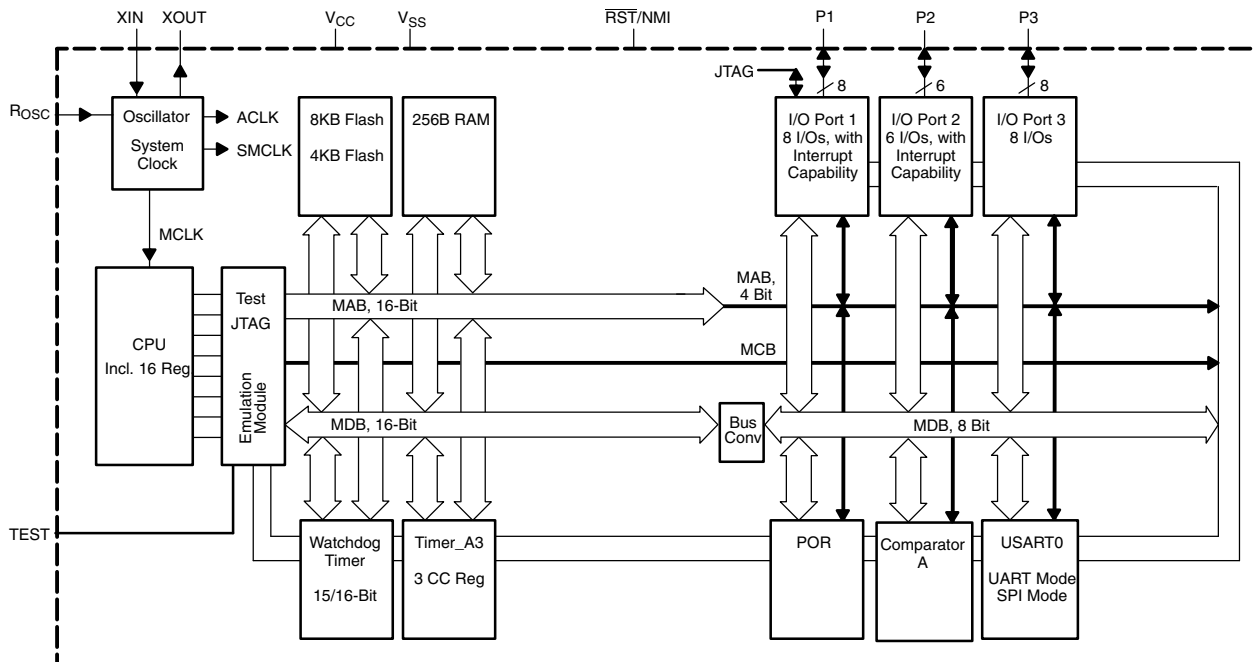

Terminal Functions

TERMINAL			I/O	DESCRIPTION
NAME	DW, PW	RHB		
	NO.	NO.		
P1.0/TACLK	21	21	I/O	General-purpose digital I/O pin/Timer_A, clock signal TACLK input
P1.1/TA0	22	22	I/O	General-purpose digital I/O pin/Timer_A, capture: CCI0A input, compare: Out0 output/BSL transmit
P1.2/TA1	23	23	I/O	General-purpose digital I/O pin/Timer_A, capture: CCI1A input, compare: Out1 output
P1.3/TA2	24	24	I/O	General-purpose digital I/O pin/Timer_A, capture: CCI2A input, compare: Out2 output
P1.4/SMCLK/TCK	25	25	I/O	General-purpose digital I/O pin/SMCLK signal output/test clock, input terminal for device programming and test
P1.5/TA0/TMS	26	26	I/O	General-purpose digital I/O pin/Timer_A, compare: Out0 output/test mode select, input terminal for device programming and test
P1.6/TA1/TDI/TCLK	27	27	I/O	General-purpose digital I/O pin/Timer_A, compare: Out1 output/test data input terminal or test clock input
P1.7/TA2/TDO/TDI†	28	28	I/O	General-purpose digital I/O pin/Timer_A, compare: Out2 output/test data output terminal or data input during programming
P2.0/ACLK	8	6	I/O	General-purpose digital I/O pin/ACLK output
P2.1/INCLK	9	7	I/O	General-purpose digital I/O pin/Timer_A, clock signal at INCLK
P2.2/CAOUT/TA0	10	8	I/O	General-purpose digital I/O pin/Timer_A, capture: CCI0B input/comparator_A, output/BSL receive
P2.3/CA0/TA1	19	18	I/O	General-purpose digital I/O pin/Timer_A, compare: Out1 output/comparator_A, input
P2.4/CA1/TA2	20	19	I/O	General-purpose digital I/O pin/Timer_A, compare: Out2 output/comparator_A, input
P2.5/R _{OSC}	3	32	I/O	General-purpose digital I/O pin/Input for external resistor that defines the DCO nominal frequency
P3.0/STE0	11	9	I/O	General-purpose digital I/O pin/slave transmit enable—USART0/SPI mode
P3.1/SIMO0	12	10	I/O	General-purpose digital I/O pin/slave in/master out of USART0/SPI mode
P3.2/SOMI0	13	11	I/O	General-purpose digital I/O pin/slave out/master in of USART0/SPI mode
P3.3/UCLK0	14	12	I/O	General-purpose digital I/O pin/external clock input—USART0/UART or SPI mode, clock output—USART0/SPI mode clock input
P3.4/UTXD0	15	13	I/O	General-purpose digital I/O pin/transmit data out—USART0/UART mode
P3.5/URXD0	16	14	I/O	General-purpose digital I/O pin/receive data in—USART0/UART mode
P3.6	17	15	I/O	General-purpose digital I/O pin
P3.7	18	16	I/O	General-purpose digital I/O pin
RST/NMI	7	5	I	Reset or nonmaskable interrupt input
TEST	1	29	I	Selects test mode for JTAG pins on Port1
V _{CC}	2	30		Supply voltage
V _{SS}	4	1		Ground reference
XIN	6	3	I	Input terminal of crystal oscillator
XOUT	5	2	O	Output terminal of crystal oscillator
NC		4, 17, 20, 31		No internal connection
QFN Pad	NA	Package Pad	NA	QFN package pad connection to V _{SS} recommended.

† TDO or TDI is selected via JTAG instruction.

MSP430x12x MIXED SIGNAL MICROCONTROLLER

SLAS312C – JULY 2001 – REVISED SEPTEMBER 2004

short-form description

CPU

The MSP430 CPU has a 16-bit RISC architecture that is highly transparent to the application. All operations, other than program-flow instructions, are performed as register operations in conjunction with seven addressing modes for source operand and four addressing modes for destination operand.

The CPU is integrated with 16 registers that provide reduced instruction execution time. The register-to-register operation execution time is one cycle of the CPU clock.

Four of the registers, R0 to R3, are dedicated as program counter, stack pointer, status register, and constant generator respectively. The remaining registers are general-purpose registers.

Peripherals are connected to the CPU using data, address, and control buses, and can be handled with all instructions.

instruction set

The instruction set consists of 51 instructions with three formats and seven address modes. Each instruction can operate on word and byte data. Table 1 shows examples of the three types of instruction formats; the address modes are listed in Table 2.

Program Counter	PC/R0
Stack Pointer	SP/R1
Status Register	SR/CG1/R2
Constant Generator	CG2/R3
General-Purpose Register	R4
General-Purpose Register	R5
General-Purpose Register	R6
General-Purpose Register	R7
General-Purpose Register	R8
General-Purpose Register	R9
General-Purpose Register	R10
General-Purpose Register	R11
General-Purpose Register	R12
General-Purpose Register	R13
General-Purpose Register	R14
General-Purpose Register	R15

Table 1. Instruction Word Formats

Dual operands, source-destination	e.g. ADD R4,R5	R4 + R5 ----> R5
Single operands, destination only	e.g. CALL R8	PC --->(TOS), R8---> PC
Relative jump, un/conditional	e.g. JNE	Jump-on-equal bit = 0

Table 2. Address Mode Descriptions

ADDRESS MODE	S	D	SYNTAX	EXAMPLE	OPERATION
Register	●	●	MOV Rs,Rd	MOV R10,R11	R10 --> R11
Indexed	●	●	MOV X(Rn),Y(Rm)	MOV 2(R5),6(R6)	M(2+R5)---> M(6+R6)
Symbolic (PC relative)	●	●	MOV EDE,TONI		M(EDE) ---> M(TONI)
Absolute	●	●	MOV &MEM,&TCDAT		M(MEM) ---> M(TCDAT)
Indirect	●		MOV @Rn,Y(Rm)	MOV @R10,Tab(R6)	M(R10) ---> M(Tab+R6)
Indirect autoincrement	●		MOV @Rn+,Rm	MOV @R10+,R11	M(R10) ---> R11 R10 + 2---> R10
Immediate	●		MOV #X,TONI	MOV #45,TONI	#45 ---> M(TONI)

NOTE: S = source D = destination



POST OFFICE BOX 655303 • DALLAS, TEXAS 75265

operating modes

The MSP430 has one active mode and five software selectable low-power modes of operation. An interrupt event can wake up the device from any of the five low-power modes, service the request and restore back to the low-power mode on return from the interrupt program.

The following six operating modes can be configured by software:

- Active mode AM;
 - All clocks are active
- Low-power mode 0 (LPM0);
 - CPU is disabled
ACLK and SMCLK remain active. MCLK is disabled
- Low-power mode 1 (LPM1);
 - CPU is disabled
ACLK and SMCLK remain active. MCLK is disabled
DCO's dc-generator is disabled if DCO not used in active mode
- Low-power mode 2 (LPM2);
 - CPU is disabled
MCLK and SMCLK are disabled
DCO's dc-generator remains enabled
ACLK remains active
- Low-power mode 3 (LPM3);
 - CPU is disabled
MCLK and SMCLK are disabled
DCO's dc-generator is disabled
ACLK remains active
- Low-power mode 4 (LPM4);
 - CPU is disabled
ACLK is disabled
MCLK and SMCLK are disabled
DCO's dc-generator is disabled
Crystal oscillator is stopped

MSP430x12x MIXED SIGNAL MICROCONTROLLER

SLAS312C – JULY 2001 – REVISED SEPTEMBER 2004

interrupt vector addresses

The interrupt vectors and the power-up starting address are located in the address range of 0FFFFh-0FFE0h. The vector contains the 16-bit address of the appropriate interrupt handler instruction sequence.

INTERRUPT SOURCE	INTERRUPT FLAG	SYSTEM INTERRUPT	WORD ADDRESS	PRIORITY
Power-up External reset Watchdog Flash memory	WDTIFG (see Note 1) KEYV (see Note 1)	Reset	0FFFEh	15, highest
NMI Oscillator fault Flash memory access violation	NMIIFG (see Notes 1 and 4) OFIFG (see Notes 1 and 4) ACCVIFG (see Notes 1 and 4)	(non)-maskable, (non)-maskable, (non)-maskable	0FFFCh	14
			0FFFAh	13
			0FFF8h	12
Comparator_A	CAIFG	maskable	0FFF6h	11
Watchdog timer	WDTIFG	maskable	0FFF4h	10
Timer_A3	TACCR0 CCIFG (see Note 2)	maskable	0FFF2h	9
Timer_A3	TACCR1 and TACCR2 CCIFGs, TAIFG (see Notes 1 and 2)	maskable	0FFF0h	8
USART0 receive	URXIFG0	maskable	0FFEEh	7
USART0 transmit	UTXIFG0	maskable	0FFEC h	6
			0FFEAh	5
			0FFE8h	4
I/O Port P2 (eight flags – see Note 3)	P2IFG.0 to P2IFG.7 (see Notes 1 and 2)	maskable	0FFE6h	3
I/O Port P1 (eight flags)	P1IFG.0 to P1IFG.7 (see Notes 1 and 2)	maskable	0FFE4h	2
			0FFE2h	1
			0FFE0h	0, lowest

- NOTES:
- Multiple source flags
 - Interrupt flags are located in the module
 - There are eight Port P2 interrupt flags, but only six Port P2 I/O pins (P2.0–5) are implemented on the '12x devices.
 - (non)-maskable: the individual interrupt enable bit can disable an interrupt event, but the general interrupt enable cannot.



special function registers

Most interrupt and module enable bits are collected into the lowest address space. Special function register bits that are not allocated to a functional purpose are not physically present in the device. Simple software access is provided with this arrangement.

interrupt enable 1 and 2

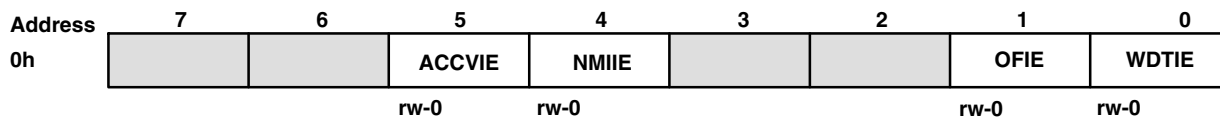

WDTIE: Watchdog-timer interrupt enable. Inactive if watchdog mode is selected. Active if watchdog timer is configured in interval timer mode.

OFIE: Oscillator-fault-interrupt enable

NMIIE: Nonmaskable-interrupt enable

ACCVIE: Flash access violation interrupt enable

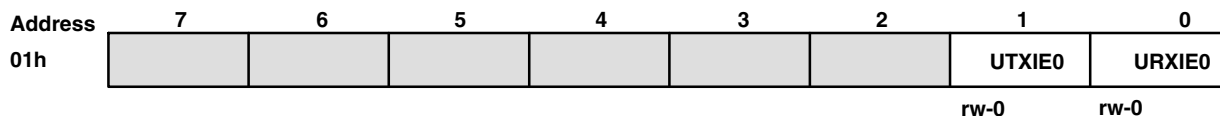

URXIE0: USART0: UART and SPI receive-interrupt enable

UTXIE0: USART0: UART and SPI transmit-interrupt enable

interrupt flag register 1 and 2

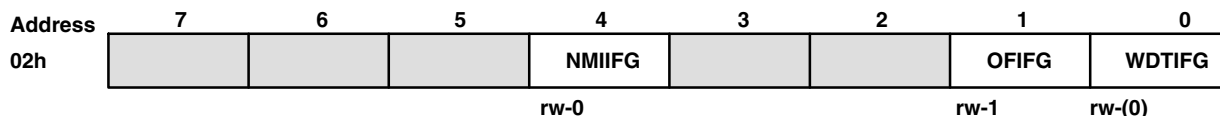

WDTIFG: Set on watchdog timer overflow (in watchdog mode) or security key violation. Reset on V_{CC} power up or a reset condition at the \overline{RST}/NMI pin in reset mode.

OFIFG: Flag set on oscillator fault

NMIIFG: Set via \overline{RST}/NMI pin

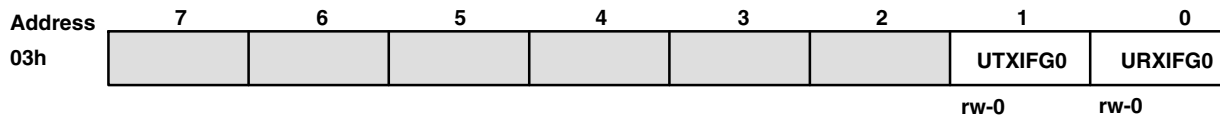

URXIFG0: USART0: UART and SPI receive flag

UTXIFG0: USART0: UART and SPI transmit flag

MSP430x12x MIXED SIGNAL MICROCONTROLLER

SLAS312C – JULY 2001 – REVISED SEPTEMBER 2004

module enable registers 1 and 2

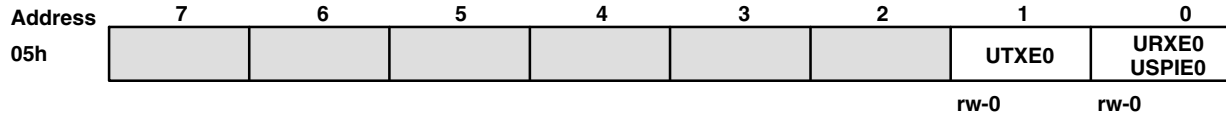
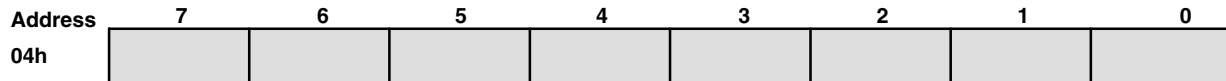

URXE0: USART0: UART receive enable

UTXE0: USART0: UART transmit enable

USPIE0: USART0: SPI (synchronous peripheral interface) transmit and receive enable

Legend rw: Bit can be read and written.
 rw-0,1: Bit can be read and written. It is Reset or Set by PUC
 rw-(0,1): Bit can be read and written. It is Reset or Set by POR
 [Grey Box] SFR bit is not present in device.

memory organization

		MSP430F122	MSP430F123
Memory	Size	4KB Flash	8KB Flash
Main: interrupt vector	Flash	0FFFFh–0FFE0h	0FFFFh–0FFE0h
Main: code memory	Flash	0FFFFh–0F000h	0FFFFh–0E000h
Information memory	Size	256 Byte	256 Byte
	Flash	010FFh – 01000h	010FFh – 01000h
Boot memory	Size	1KB	1KB
	ROM	0FFFh – 0C00h	0FFFh – 0C00h
RAM	Size	256 Byte	256 Byte
		02FFh – 0200h	02FFh – 0200h
Peripherals	16-bit	01FFh – 0100h	01FFh – 0100h
	8-bit	0FFh – 010h	0FFh – 010h
	8-bit SFR	0Fh – 00h	0Fh – 00h

bootstrap loader (BSL)

The MSP430 bootstrap loader (BSL) enables users to program the flash memory or RAM using a UART serial interface. Access to the MSP430 memory via the BSL is protected by user-defined password. For complete description of the features of the BSL and its implementation, see the Application report *Features of the MSP430 Bootstrap Loader*, Literature Number SLAA089.

BSL Function	DW & PW Package Pins	RHB Package Pins
Data Transmit	22 - P1.1	22 - P1.1
Data Receive	10 - P2.2	8 - P2.2

flash memory

The flash memory can be programmed via the JTAG port, the bootstrap loader, or in-system by the CPU. The CPU can perform single-byte and single-word writes to the flash memory. Features of the flash memory include:

- Flash memory has n segments of main memory and two segments of information memory (A and B) of 128 bytes each. Each segment in main memory is 512 bytes in size.
- Segments 0 to n may be erased in one step, or each segment may be individually erased.
- Segments A and B can be erased individually, or as a group with segments 0–n. Segments A and B are also called *information memory*.
- New devices may have some bytes programmed in the information memory (needed for test during manufacturing). The user should perform an erase of the information memory prior to the first use.

peripherals

Peripherals are connected to the CPU through data, address, and control busses and can be handled using all instructions. For complete module descriptions, see the *MSP430x1xx Family User's Guide*, literature number SLAU049.

oscillator and system clock

The clock system in the MSP430x12x devices is supported by the basic clock module that includes support for a 32768-Hz watch crystal oscillator, an internal digitally-controlled oscillator (DCO) and a high frequency crystal oscillator. The basic clock module is designed to meet the requirements of both low system cost and low-power consumption. The internal DCO provides a fast turn-on clock source and stabilizes in less than 6 μ s. The basic clock module provides the following clock signals:

- Auxiliary clock (ACLK), sourced from a 32768-Hz watch crystal or a high frequency crystal.
- Main clock (MCLK), the system clock used by the CPU.
- Sub-Main clock (SMCLK), the sub-system clock used by the peripheral modules.

digital I/O

There are three 8-bit I/O ports implemented—ports P1, P2, and P3 (only six port P2 I/O signals are available on external pins):

- All individual I/O bits are independently programmable.
- Any combination of input, output, and interrupt conditions is possible.
- Edge-selectable interrupt input capability for all the eight bits of ports P1 and six bits of port P2.
- Read/write access to port-control registers is supported by all instructions.

NOTE:

Six bits of port P2, P2.0 to P2.5, are available on external pins – but all control and data bits for port P2 are implemented. Port P3 has no interrupt capability.

watchdog timer

The primary function of the watchdog timer (WDT) module is to perform a controlled system restart after a software problem occurs. If the selected time interval expires, a system reset is generated. If the watchdog function is not needed in an application, the module can be configured as an interval timer and can generate interrupts at selected time intervals.

MSP430x12x MIXED SIGNAL MICROCONTROLLER

SLAS312C – JULY 2001 – REVISED SEPTEMBER 2004

USART0

The MSP430x12x devices have one hardware universal synchronous/asynchronous receive transmit (USART0) peripheral module that is used for serial data communication. The USART supports synchronous SPI (3 or 4 pin) and asynchronous UART communication protocols, using double-buffered transmit and receive channels.

timer_A3

Timer_A3 is a 16-bit timer/counter with three capture/compare registers. Timer_A3 can support multiple capture/compares, PWM outputs, and interval timing. Timer_A3 also has extensive interrupt capabilities. Interrupts may be generated from the counter on overflow conditions and from each of the capture/compare registers.

Timer_A3 Signal Connections							
Input Pin Number		Device Input Signal	Module Input Name	Module Block	Module Output Signal	Output Pin Number	
DW, PW	RHB					DW, PW	RHB
21 - P1.0	21 - P1.0	TACLK	TACLK	Timer	NA		
		ACLK	ACLK				
		SMCLK	SMCLK				
9 - P2.1	7 - P2.1	INCLK	INCLK				
22 - P1.1	22 - P1.1	TA0	CCI0A	CCR0	TA0	22 - P1.1	22 - P1.1
10 - P2.2	8 - P2.2	TA0	CCI0B			26 - P1.5	26 - P1.5
		DV _{SS}	GND				
		DV _{CC}	V _{CC}				
23 - P1.2	23 - P1.2	TA1	CCI1A	CCR1	TA1	19 - P2.3	18 - P2.3
		CAOUT (internal)	CCI1B			23 - P1.2	23 - P1.2
		DV _{SS}	GND			27 - P1.6	27 - P1.6
		DV _{CC}	V _{CC}				
24 - P1.3	24 - P1.3	TA2	CCI2A	CCR2	TA2	20 - P2.4	19 - P2.4
		ACLK (internal)	CCI2B			24 - P1.3	24 - P1.3
		DV _{SS}	GND			28 - P1.7	28 - P1.7
		DV _{CC}	V _{CC}				

comparator_A

The primary function of the comparator_A module is to support precision slope analog-to-digital conversions, battery-voltage supervision, and monitoring of external analog signals.



peripheral file map

PERIPHERALS WITH WORD ACCESS			
Timer_A	Reserved		017Eh
	Reserved		017Ch
	Reserved		017Ah
	Reserved		0178h
	Capture/compare register	TACCR2	0176h
	Capture/compare register	TACCR1	0174h
	Capture/compare register	TACCR0	0172h
	Timer_A register	TAR	0170h
	Reserved		016Eh
	Reserved		016Ch
	Reserved		016Ah
	Reserved		0168h
	Capture/compare control	TACCTL2	0166h
	Capture/compare control	TACCTL1	0164h
	Capture/compare control	TACCTL0	0162h
Timer_A control	TACTL	0160h	
Timer_A interrupt vector	TAIV	012Eh	
Flash Memory	Flash control 3	FCTL3	012Ch
	Flash control 2	FCTL2	012Ah
	Flash control 1	FCTL1	0128h
Watchdog	Watchdog/timer control	WDTCTL	0120h
PERIPHERALS WITH BYTE ACCESS			
USART0	Transmit buffer	U0TXBUF	077h
	Receive buffer	U0RXBUF	076h
	Baud rate	U0BR1	075h
	Baud rate	U0BR0	074h
	Modulation control	U0MCTL	073h
	Receive control	U0RCTL	072h
	Transmit control	U0TCTL	071h
	USART control	U0CTL	070h
Comparator_A	Comparator_A port disable	CAPD	05Bh
	Comparator_A control2	CACTL2	05Ah
	Comparator_A control1	CACTL1	059h
Basic Clock	Basic clock sys. control2	BCSCTL2	058h
	Basic clock sys. control1	BCSCTL1	057h
	DCO clock freq. control	DCOCTL	056h
Port P3	Port P3 selection	P3SEL	01Bh
	Port P3 direction	P3DIR	01Ah
	Port P3 output	P3OUT	019h
	Port P3 input	P3IN	018h
Port P2	Port P2 selection	P2SEL	02Eh
	Port P2 interrupt enable	P2IE	02Dh
	Port P2 interrupt edge select	P2IES	02Ch
	Port P2 interrupt flag	P2IFG	02Bh
	Port P2 direction	P2DIR	02Ah
	Port P2 output	P2OUT	029h
	Port P2 input	P2IN	028h
Port P1	Port P1 selection	P1SEL	026h
	Port P1 interrupt enable	P1IE	025h
	Port P1 interrupt edge select	P1IES	024h
	Port P1 interrupt flag	P1IFG	023h
	Port P1 direction	P1DIR	022h
	Port P1 output	P1OUT	021h
	Port P1 input	P1IN	020h

MSP430x12x MIXED SIGNAL MICROCONTROLLER

SLAS312C – JULY 2001 – REVISED SEPTEMBER 2004

peripheral file map (continued)

PERIPHERALS WITH BYTE ACCESS (CONTINUED)			
Special Function			
	Module enable2	ME2	005h
	Module enable1	ME1	004h
	SFR interrupt flag2	IFG2	003h
	SFR interrupt flag1	IFG1	002h
	SFR interrupt enable2	IE2	001h
	SFR interrupt enable1	IE1	000h

absolute maximum ratings†

Voltage applied at V_{CC} to V_{SS}	-0.3 V to 4.1 V
Voltage applied to any pin (see Note)	-0.3 V to $V_{CC}+0.3$ V
Diode current at any device terminal	± 2 mA
Storage temperature, T_{stg} (unprogrammed device)	-55°C to 150°C
Storage temperature, T_{stg} (programmed device)	-40°C to 85°C

† Stresses beyond those listed under “absolute maximum ratings” may cause permanent damage to the device. These are stress ratings only, and functional operation of the device at these or any other conditions beyond those indicated under “recommended operating conditions” is not implied. Exposure to absolute-maximum-rated conditions for extended periods may affect device reliability.

NOTE: All voltages referenced to V_{SS} . The JTAG fuse-blow voltage, V_{FB} , is allowed to exceed the absolute maximum rating. The voltage is applied to the TEST pin when blowing the JTAG fuse.

recommended operating conditions

		MIN	NOM	MAX	UNITS
Supply voltage during program execution, V_{CC} (see Note 1)		1.8		3.6	V
Supply voltage during program/erase flash memory, V_{CC}		2.7		3.6	V
Supply voltage, V_{SS}			0		V
Operating free-air temperature range, T_A		-40		85	°C
LFXT1 crystal frequency, $f_{(LFXT1)}$ (see Note 2)	LF mode selected, $XTS=0$	Watch crystal		32768	Hz
	XT1 selected mode, $XTS=1$	Ceramic resonator		450	8000
		Crystal		1000	8000
Processor frequency $f_{(system)}$ (MCLK signal)	$V_{CC} = 1.8$ V	dc		4.15	MHz
	$V_{CC} = 3.6$ V	dc		8	

NOTES: 1. The LFXT1 oscillator in LF-mode requires a resistor of 5.1 MΩ from XOUT to V_{SS} when $V_{CC} < 2.5$ V. The LFXT1 oscillator in XT1-mode accepts a ceramic resonator or a crystal frequency of 4 MHz at $V_{CC} \geq 2.2$ V. The LFXT1 oscillator in XT1-mode accepts a ceramic resonator or a crystal frequency of 8 MHz at $V_{CC} \geq 2.8$ V.
2. The LFXT1 oscillator in LF-mode requires a watch crystal. The LFXT1 oscillator in XT1-mode accepts a ceramic resonator or crystal.

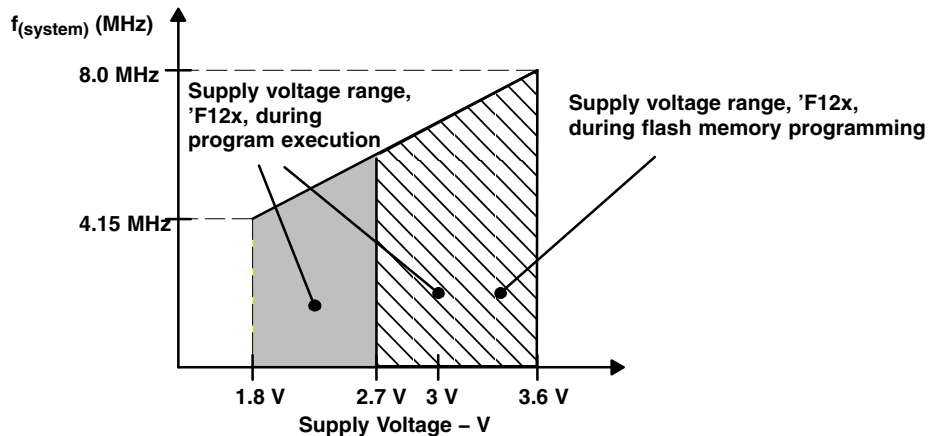

NOTE: Minimum processor frequency is defined by system clock. Flash program or erase operations require a minimum V_{CC} of 2.7 V.

Figure 1. Frequency vs Supply Voltage, MSP430F12x



electrical characteristics over recommended ranges of supply voltage and operating free-air temperature (unless otherwise noted)

supply current (into V_{CC}) excluding external current

PARAMETER		TEST CONDITIONS	MIN	TYP	MAX	UNIT	
I _(AM)	Active mode	T _A = -40°C +85°C, f _(MCLK) = f _(SMCLK) = 1 MHz, f _(ACLK) = 32,768 Hz, Program executes in Flash	V _{CC} = 2.2 V	200	250	μA	
			V _{CC} = 3 V	300	350		
		T _A = -40°C +85°C, f _(MCLK) = f _(SMCLK) = f _(ACLK) = 4096 Hz, Program executes in Flash	V _{CC} = 2.2 V	3	5	μA	
			V _{CC} = 3 V	11	18		
I _(CPUOff)	Low-power mode, (LPM0)	T _A = -40°C +85°C, f _(MCLK) = 0, f _(SMCLK) = 1 MHz, f _(ACLK) = 32,768 Hz	V _{CC} = 2.2 V	32	45	μA	
			V _{CC} = 3 V	55	70		
I _(LPM2)	Low-power mode, (LPM2)	T _A = -40°C +85°C, f _(MCLK) = f _(SMCLK) = 0 MHz, f _(ACLK) = 32,768 Hz, SCG0 = 0	V _{CC} = 2.2 V	11	14	μA	
			V _{CC} = 3 V	17	22		
I _(LPM3)	Low-power mode, (LPM3)		V _{CC} = 2.2 V	T _A = -40°C	0.8	1.2	μA
				T _A = 25°C	0.7	1	
				T _A = 85°C	1.6	2.3	
			V _{CC} = 3 V	T _A = -40°C	1.8	2.2	μA
				T _A = 25°C	1.6	1.9	
				T _A = 85°C	2.3	3.4	
I _(LPM4)	Low-power mode, (LPM4)		V _{CC} = 2.2 V/3 V	T _A = -40°C	0.1	0.5	μA
				T _A = 25°C	0.1	0.5	
				T _A = 85°C	0.8	1.9	

NOTE: All inputs are tied to 0 V or V_{CC}. Outputs do not source or sink any current.

current consumption of active mode versus system frequency

$$I_{AM} = I_{AM[1 \text{ MHz}]} \times f_{\text{system}} [\text{MHz}]$$

current consumption of active mode versus supply voltage

$$I_{AM} = I_{AM[3 \text{ V}]} + 120 \mu\text{A/V} \times (V_{CC} - 3 \text{ V})$$

MSP430x12x MIXED SIGNAL MICROCONTROLLER

SLAS312C – JULY 2001 – REVISED SEPTEMBER 2004

electrical characteristics over recommended ranges of supply voltage and operating free-air temperature (unless otherwise noted) (continued)

Schmitt-trigger inputs Port P1 to Port P3; P1.0 to P1.7, P2.0 to P2.5, P3.0 to P3.7

PARAMETER		V _{CC}	MIN	TYP	MAX	UNIT
V _{IT+}	Positive-going input threshold voltage	2.2 V	1.1		1.5	V
		3 V	1.5		1.9	
V _{IT-}	Negative-going input threshold voltage	2.2 V	0.4		0.9	V
		3 V	0.9		1.3	
V _{hys}	Input voltage hysteresis, (V _{IT+} – V _{IT-})	2.2 V	0.3		1.1	V
		3 V	0.5		1	

standard inputs – RST/NMI, TEST; JTAG: TCK, TMS, TDI/TCLK

PARAMETER		V _{CC}	MIN	TYP	MAX	UNIT
V _{IL}	Low-level input voltage	2.2 V/3 V	V _{SS}		V _{SS} +0.6	V
V _{IH}	High-level input voltage		0.8×V _{CC}		V _{CC}	V

inputs Px.x, TA_x

PARAMETER	TEST CONDITIONS	V _{CC}	MIN	TYP	MAX	UNIT
t _(int)	Port P1, P2: P1.x to P2.x, External trigger signal for the interrupt flag, (see Note 1)	2.2 V/3 V	1.5			cycle
		2.2 V	62			ns
		3 V	50			
t _(cap)	Timer_A, capture timing	TA0, TA1, TA2	2.2 V	62		ns
			3 V	50		
f _(TAext)	Timer_A clock frequency externally applied to pin	TACLK, INCLK t _(H) = t _(L)	2.2 V		8	MHz
			3 V		10	
f _(TAint)	Timer_A clock frequency	SMCLK or ACLK signal selected	2.2 V		8	MHz
			3 V		10	

NOTES: 1. The external signal sets the interrupt flag every time the minimum t_(int) cycle and time parameters are met. It may be set even with trigger signals shorter than t_(int). Both the cycle and timing specifications must be met to ensure the flag is set. t_(int) is measured in MCLK cycles.

leakage current (see Notes 1 and 2)

PARAMETER	TEST CONDITIONS	V _{CC}	MIN	TYP	MAX	UNIT
I _{lkg} (Px.x)	Port P1: P1.x, 0 ≤ x ≤ 7	2.2 V/3 V			±50	nA
	Port P2: P2.x, 0 ≤ x ≤ 5				±50	

NOTES: 1. The leakage current is measured with V_{SS} or V_{CC} applied to the corresponding pin(s), unless otherwise noted.
2. The leakage of the digital port pins is measured individually. The port pin must be selected for input and there must be no optional pullup or pulldown resistor.



electrical characteristics over recommended ranges of supply voltage and operating free-air temperature (unless otherwise noted) (continued)

outputs Port 1 to Port 3; P1.0 to P1.7, P2.0 to P2.5, P3.0 to P3.7

PARAMETER		TEST CONDITIONS			MIN	TYP	MAX	UNIT
V _{OH}	High-level output voltage	I _(OHmax) = -1.5 mA	V _{CC} = 2.2 V	See Note 1	V _{CC} -0.25		V _{CC}	V
		I _(OHmax) = -6 mA		See Note 2	V _{CC} -0.6		V _{CC}	
		I _(OHmax) = -1.5 mA	V _{CC} = 3 V	See Note 1	V _{CC} -0.25		V _{CC}	
		I _(OHmax) = -6 mA		See Note 2	V _{CC} -0.6		V _{CC}	
V _{OL}	Low-level output voltage	I _(OLmax) = 1.5 mA	V _{CC} = 2.2 V	See Note 1	V _{SS}		V _{SS} +0.25	V
		I _(OLmax) = 6 mA		See Note 2	V _{SS}		V _{SS} +0.6	
		I _(OLmax) = 1.5 mA	V _{CC} = 3 V	See Note 1	V _{SS}		V _{SS} +0.25	
		I _(OLmax) = 6 mA		See Note 2	V _{SS}		V _{SS} +0.6	

- NOTES: 1. The maximum total current, I_{OHmax} and I_{OLmax}, for all outputs combined, should not exceed ±12 mA to hold the maximum voltage drop specified.
 2. The maximum total current, I_{OHmax} and I_{OLmax}, for all outputs combined, should not exceed ±48 mA to hold the maximum voltage drop specified.

outputs P1.x, P2.x, P3.x, TAx

PARAMETER		TEST CONDITIONS		V _{CC}	MIN	TYP	MAX	UNIT
f _(P20)	Output frequency	P2.0/ACLK; C _L = 20 pF		2.2 V/3 V			f _{System}	MHz
f _(TAx)		TA0, TA1, TA2; C _L = 20 pF, Internal clock source, SMCLK signal applied (see Note 1)		2.2 V/3 V	dc		f _{System}	
t _(Xdc)	Duty cycle of O/P frequency	P1.4/SMCLK, C _L = 20 pF	f _{SMCLK} = f _{LFXT1} = f _{XT1}	2.2 V/3 V	40%		60%	
			f _{SMCLK} = f _{LFXT1} = f _{LF}		35%		65%	
			f _{SMCLK} = f _{LFXT1/n}	50%-15 ns	50%	50%+15 ns		
			f _{SMCLK} = f _{DCOCLK}	2.2 V/3 V	50%-15 ns	50%	50%+15 ns	
		P2.0/ACLK, C _L = 20 pF	f _{P20} = f _{LFXT1} = f _{XT1}	2.2 V/3 V	40%		60%	
			f _{P20} = f _{LFXT1} = f _{LF}		30%		70%	
f _{P20} = f _{LFXT1/n}			50%					
t _(TAdc)		TA0, TA1, TA2; C _L = 20 pF, Duty cycle = 50%	2.2 V/3 V		0		±50	ns

NOTE 1: The limits of the system clock MCLK has to be met. MCLK and SMCLK can have different frequencies.

MSP430x12x MIXED SIGNAL MICROCONTROLLER

SLAS312C – JULY 2001 – REVISED SEPTEMBER 2004

electrical characteristics over recommended operating free-air temperature (unless otherwise noted) (continued)

outputs – Ports P1, P2, and P3

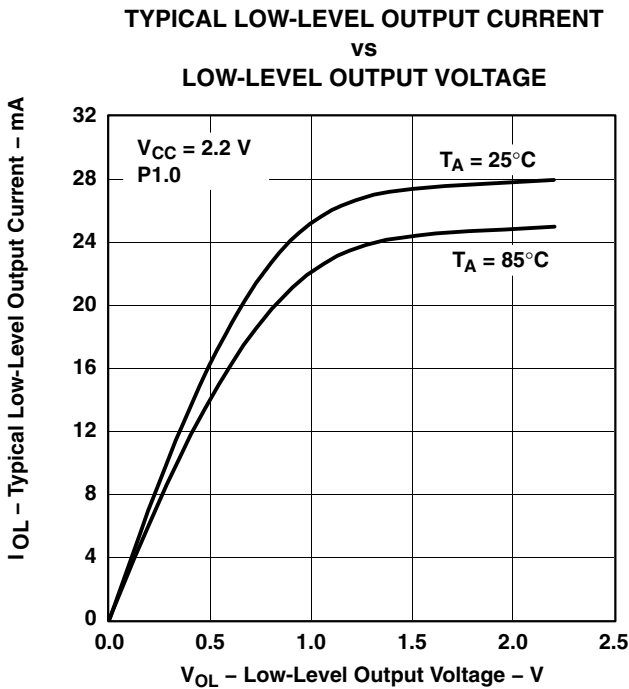

Figure 2

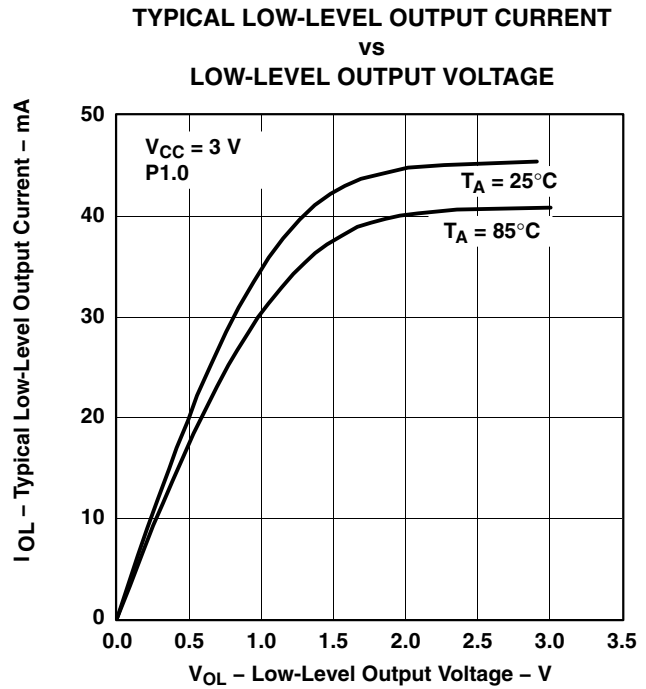

Figure 3

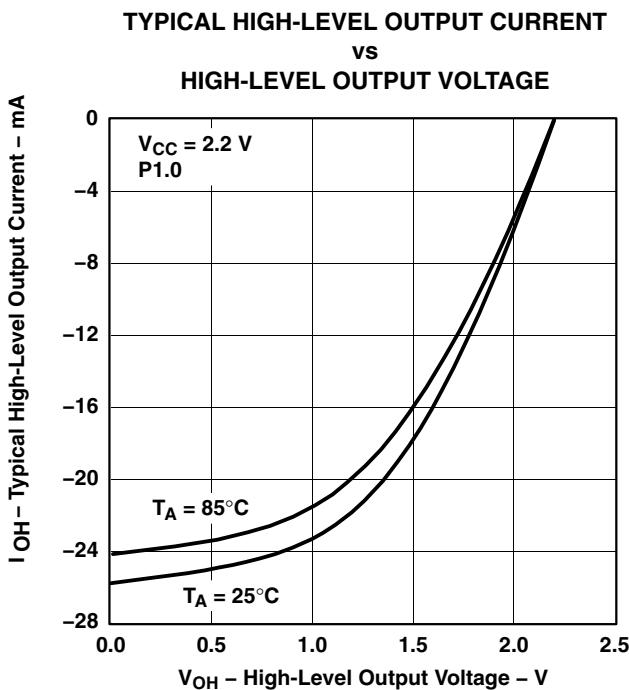

Figure 4

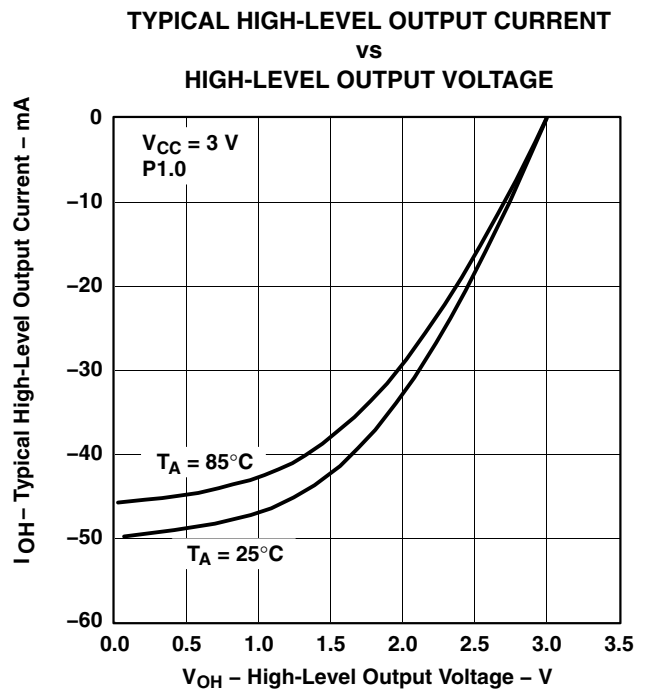

Figure 5

NOTE: Only one output is loaded at a time.

electrical characteristics over recommended ranges of supply voltage and operating free-air temperature (unless otherwise noted) (continued)

USART (see Note 1)

PARAMETER		TEST CONDITIONS	MIN	TYP	MAX	UNIT
$t_{(\tau)}$	USART: deglitch time	$V_{CC} = 2.2\text{ V}$	200	430	800	ns
		$V_{CC} = 3\text{ V}$	150	280	500	

NOTE 1: The signal applied to the USART receive signal/terminal (URXD) should meet the timing requirements of $t_{(\tau)}$ to ensure that the URXS flip-flop is set. The URXS flip-flop is set with negative pulses meeting the minimum-timing condition of $t_{(\tau)}$. The operating conditions to set the flag must be met independently from this timing constraint. The deglitch circuitry is active only on negative transitions on the URXD line.

wake-up from lower power modes (LPMx)

PARAMETER		TEST CONDITIONS	MIN	TYP	MAX	UNIT	
$t_{(LPM0)}$	Delay time (see Note 1)	$V_{CC} = 2.2\text{ V}/3\text{ V}$		100		ns	
$t_{(LPM2)}$		$V_{CC} = 2.2\text{ V}/3\text{ V}$		100			
$t_{(LPM3)}$		$f_{(MCLK)} = 1\text{ MHz}, V_{CC} = 2.2\text{ V}/3\text{ V}$				6	μs
		$f_{(MCLK)} = 2\text{ MHz}, V_{CC} = 2.2\text{ V}/3\text{ V}$				6	
		$f_{(MCLK)} = 3\text{ MHz}, V_{CC} = 2.2\text{ V}/3\text{ V}$				6	
$t_{(LPM4)}$		$f_{(MCLK)} = 1\text{ MHz}, V_{CC} = 2.2\text{ V}/3\text{ V}$				6	μs
		$f_{(MCLK)} = 2\text{ MHz}, V_{CC} = 2.2\text{ V}/3\text{ V}$				6	
		$f_{(MCLK)} = 3\text{ MHz}, V_{CC} = 2.2\text{ V}/3\text{ V}$				6	

NOTE 1: Parameter applicable only if DCOCLK is used for MCLK.

RAM

PARAMETER		MIN	NOM	MAX	UNIT
$V_{(RAMh)}$	CPU halted (see Note 1)	1.6			V

NOTE 1: This parameter defines the minimum supply voltage V_{CC} when the data in the program memory RAM remains unchanged. No program execution should happen during this supply voltage condition.

MSP430x12x MIXED SIGNAL MICROCONTROLLER

SLAS312C – JULY 2001 – REVISED SEPTEMBER 2004

electrical characteristics over recommended ranges of supply voltage and operating free-air temperature (unless otherwise noted) (continued)

Comparator_A (see Note 1)

PARAMETER	TEST CONDITIONS	V _{CC}	MIN	TYP	MAX	UNIT	
I _(DD)	CAON=1, CARSEL=0, CAREF=0	2.2 V		25	40	μA	
		3 V		45	60		
I _(RefLadder/ RefDiode)	CAON=1, CARSEL=0, CAREF=1/2/3, No load at P2.3/CA0/TA1 and P2.4/CA1/TA2	2.2 V		30	50	μA	
		3 V		45	71		
V _(IC)	Common-mode input voltage	CAON =1	2.2 V/3 V	0	V _{CC} -1	V	
V _(Ref025)	Voltage at 0.25 V _{CC} node $\frac{V_{CC}}{4}$	PCA0=1, CARSEL=1, CAREF=1, No load at P2.3/CA0/TA1 and P2.4/CA1/TA2	2.2 V/3 V	0.23	0.24	0.25	
V _(Ref050)	Voltage at 0.5V _{CC} node $\frac{V_{CC}}{2}$	PCA0=1, CARSEL=1, CAREF=2, No load at P2.3/CA0/TA1 and P2.4/CA1/TA2	2.2 V/3 V	0.47	0.48	0.5	
V _(RefVT)	(see Figure 6 and Figure 7)	PCA0=1, CARSEL=1, CAREF=3, No load at P2.3/CA0/TA1 and P2.4/CA1/TA2, T _A = 85°C	2.2 V	390	480	540	mV
			3 V	400	490	550	
V _(offset)	Offset voltage	See Note 2	2.2 V/3 V	-30		30	mV
V _{hys}	Input hysteresis	CAON=1	2.2 V/3 V	0	0.7	1.4	mV
t _(response LH)		T _A = 25°C, Overdrive 10 mV, Without filter: CAF=0	2.2 V	160	210	300	ns
			3 V	80	150	240	
			2.2 V	1.4	1.9	3.4	μs
			3 V	0.9	1.5	2.6	
t _(response HL)		T _A = 25°C, Overdrive 10 mV, without filter: CAF=0	2.2 V	130	210	300	ns
			3 V	80	150	240	
			2.2 V	1.4	1.9	3.4	μs
			3 V	0.9	1.5	2.6	

- NOTES: 1. The leakage current for the Comparator_A terminals is identical to I_{lkg(Px.x)} specification.
2. The input offset voltage can be cancelled by using the CAEX bit to invert the Comparator_A inputs on successive measurements. The two successive measurements are then summed together.

electrical characteristics over recommended operating free-air temperature (unless otherwise noted) (continued)

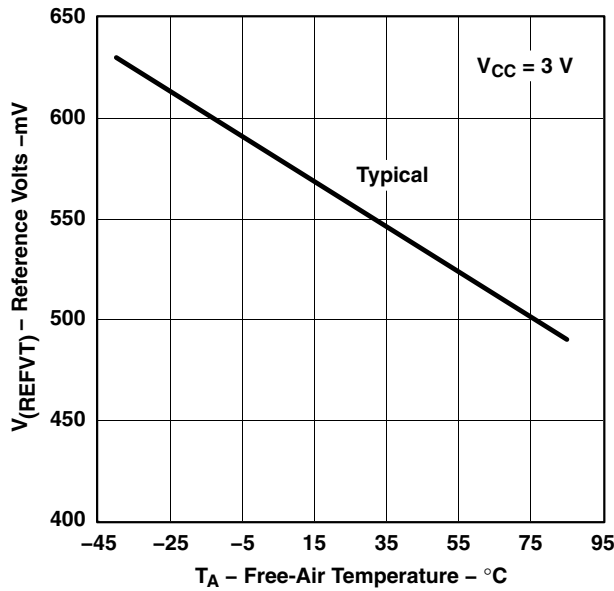

Figure 6. V_(REFVT) vs Temperature, V_{CC} = 3 V

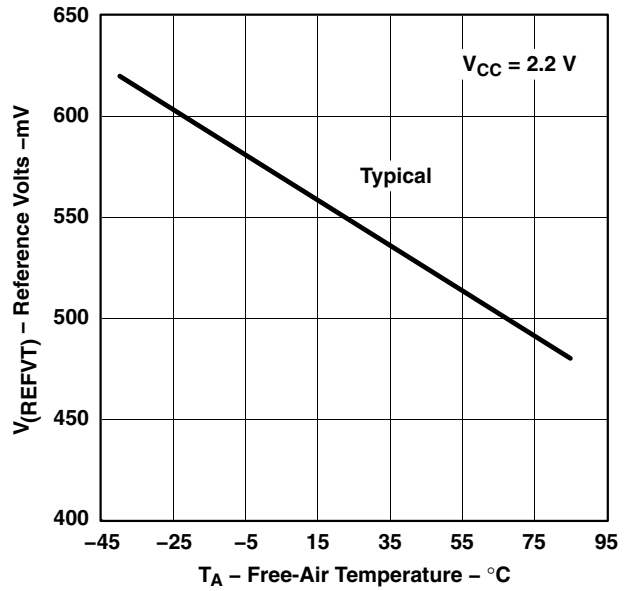

Figure 7. V_(REFVT) vs Temperature, V_{CC} = 2.2 V

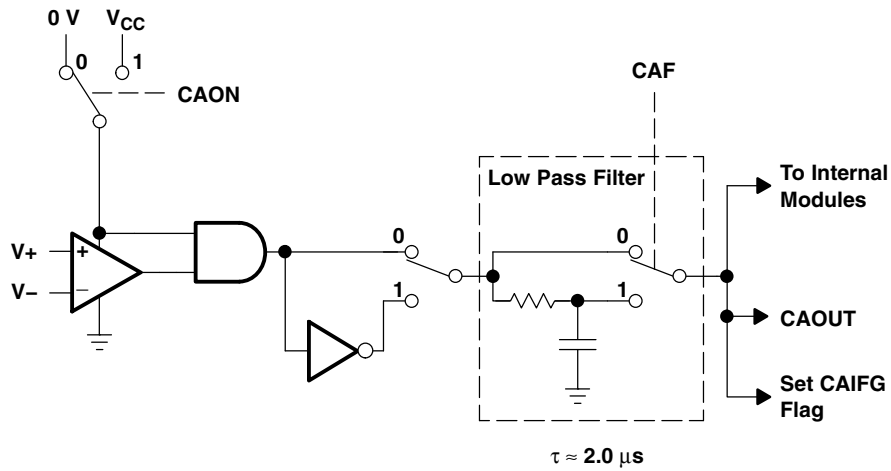

Figure 8. Block Diagram of Comparator_A Module

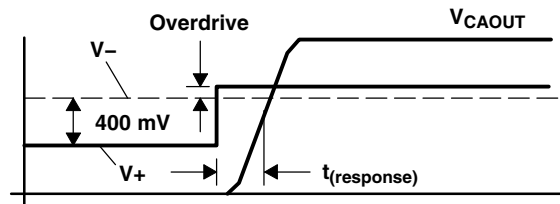

Figure 9. Overdrive Definition

MSP430x12x MIXED SIGNAL MICROCONTROLLER

SLAS312C – JULY 2001 – REVISED SEPTEMBER 2004

electrical characteristics over recommended ranges of supply voltage and operating free-air temperature (unless otherwise noted) (continued)

PUC/POR

PARAMETER	TEST CONDITIONS	MIN	TYP	MAX	UNIT	
$t_{(POR_Delay)}$	Internal time delay to release POR		150	250	μs	
V_{POR}	V_{CC} threshold at which POR release delay time begins (see Note 1)	$T_A = -40^\circ C$		1.4	1.8	V
		$T_A = 25^\circ C$		1.1	1.5	V
		$T_A = 85^\circ C$		0.8	1.2	V
$V_{(min)}$	V_{CC} threshold required to generate a POR (see Note 2)	$V_{CC} dV/dt \geq 1V/ms$		0.2	V	
$t_{(reset)}$	\overline{RST}/NMI low time for PUC/POR	Reset is accepted internally		2	μs	

NOTES: 1. V_{CC} rise time $dV/dt \geq 1V/ms$.

2. When driving V_{CC} low in order to generate a POR condition, V_{CC} should be driven to 200mV or lower with a dV/dt equal to or less than $-1V/ms$. The corresponding rising V_{CC} must also meet the dV/dt requirement equal to or greater than $+1V/ms$.

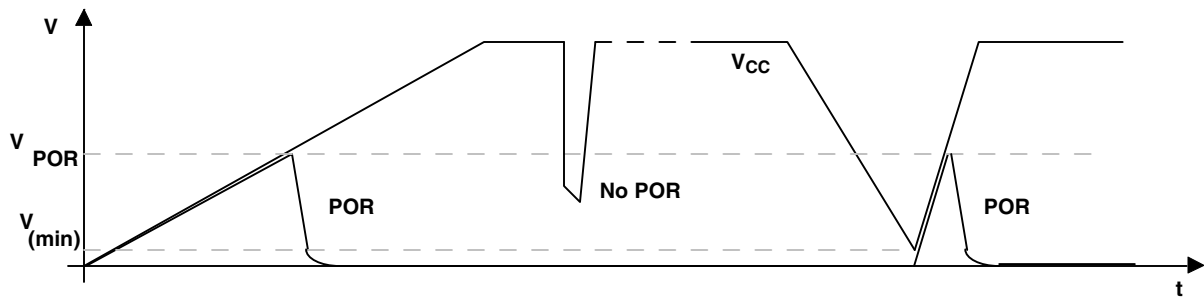

Figure 10. Power-On Reset (POR) vs Supply Voltage

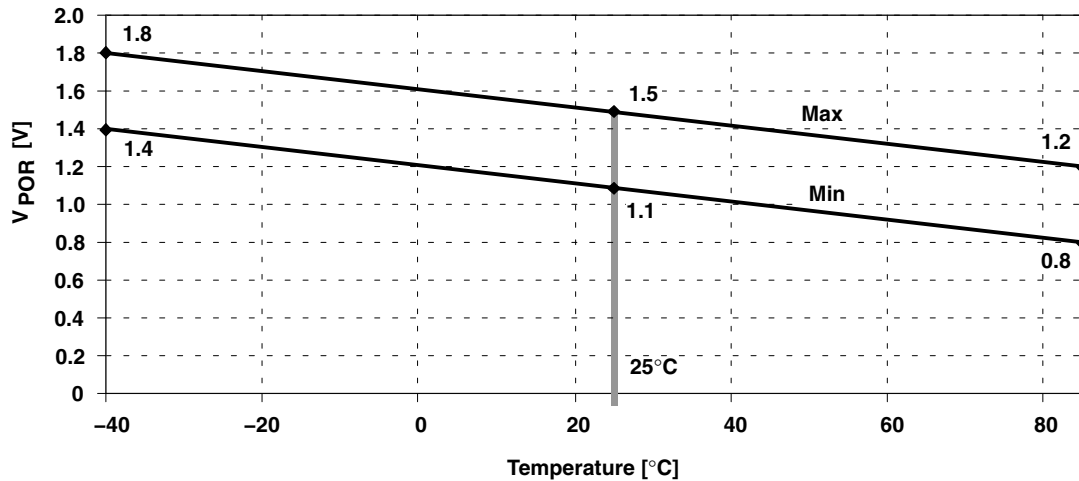

Figure 11. V_{POR} vs Temperature

electrical characteristics over recommended ranges of supply voltage and operating free-air temperature (unless otherwise noted) (continued)

DCO

PARAMETER	TEST CONDITIONS	V _{CC}	MIN	TYP	MAX	UNIT
f _(DCO03)	R _{sel} = 0, DCO = 3, MOD = 0, DCOR = 0, T _A = 25°C	2.2 V	0.08	0.12	0.15	MHz
		3 V	0.08	0.13	0.16	
f _(DCO13)	R _{sel} = 1, DCO = 3, MOD = 0, DCOR = 0, T _A = 25°C	2.2 V	0.14	0.19	0.23	MHz
		3 V	0.14	0.18	0.22	
f _(DCO23)	R _{sel} = 2, DCO = 3, MOD = 0, DCOR = 0, T _A = 25°C	2.2 V	0.22	0.30	0.36	MHz
		3 V	0.22	0.28	0.34	
f _(DCO33)	R _{sel} = 3, DCO = 3, MOD = 0, DCOR = 0, T _A = 25°C	2.2 V	0.37	0.49	0.59	MHz
		3 V	0.37	0.47	0.56	
f _(DCO43)	R _{sel} = 4, DCO = 3, MOD = 0, DCOR = 0, T _A = 25°C	2.2 V	0.61	0.77	0.93	MHz
		3 V	0.61	0.75	0.9	
f _(DCO53)	R _{sel} = 5, DCO = 3, MOD = 0, DCOR = 0, T _A = 25°C	2.2 V	1	1.2	1.5	MHz
		3 V	1	1.3	1.5	
f _(DCO63)	R _{sel} = 6, DCO = 3, MOD = 0, DCOR = 0, T _A = 25°C	2.2 V	1.6	1.9	2.2	MHz
		3 V	1.69	2	2.29	
f _(DCO73)	R _{sel} = 7, DCO = 3, MOD = 0, DCOR = 0, T _A = 25°C	2.2 V	2.4	2.9	3.4	MHz
		3 V	2.7	3.2	3.65	
f _(DCO77)	R _{sel} = 7, DCO = 7, MOD = 0, DCOR = 0, T _A = 25°C	2.2 V	4	4.5	4.9	MHz
		3 V	4.4	4.9	5.4	
f _(DCO47)	R _{sel} = 4, DCO = 7, MOD = 0, DCOR = 0, T _A = 25°C	2.2 V/3 V	F _{DCO40} x1.7	F _{DCO40} x2.1	F _{DCO40} x2.5	MHz
S _(Rsel)	S _R = f _{Rsel+1} /f _{Rsel}	2.2 V/3 V	1.35	1.65	2	ratio
S _(DCO)	S _{DCO} = f _{DCO+1} /f _{DCO}	2.2 V/3 V	1.07	1.12	1.16	ratio
D _t	Temperature drift, R _{sel} = 4, DCO = 3, MOD = 0 (see Note 1)	2.2 V	-0.31	-0.36	-0.40	%°C
		3 V	-0.33	-0.38	-0.43	
D _V	Drift with V _{CC} variation, R _{sel} = 4, DCO = 3, MOD = 0 (see Note 1)	2.2 V/3 V	0	5	10	%/V

NOTES: 1. These parameters are not production tested.

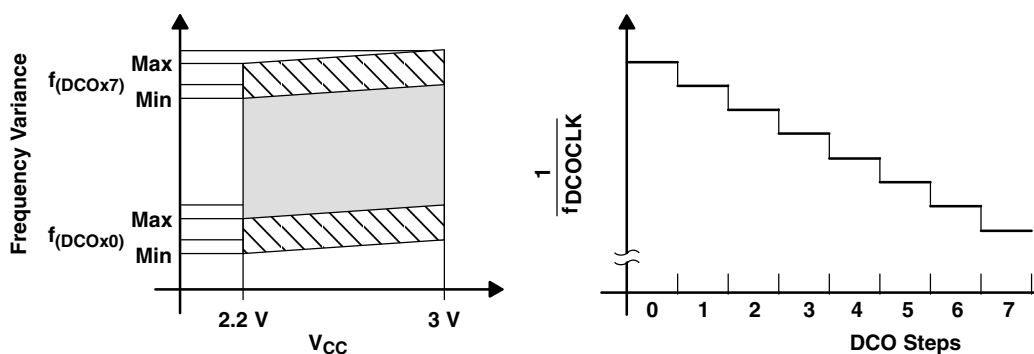

Figure 12. DCO Characteristics

MSP430x12x MIXED SIGNAL MICROCONTROLLER

SLAS312C – JULY 2001 – REVISED SEPTEMBER 2004

electrical characteristics over recommended ranges of supply voltage and operating free-air temperature (unless otherwise noted) (continued)

main DCO characteristics

- Individual devices have a minimum and maximum operation frequency. The specified parameters for $f_{(DCOx0)}$ to $f_{(DCOx7)}$ are valid for all devices.
- All ranges selected by Rsel(n) overlap with Rsel(n+1): Rsel0 overlaps Rsel1, ... Rsel6 overlaps Rsel7.
- DCO control bits DCO0, DCO1, and DCO2 have a step size as defined by parameter S_{DCO} .
- Modulation control bits MOD0 to MOD4 select how often $f_{(DCO+1)}$ is used within the period of 32 DCOCLK cycles. The frequency $f_{(DCO)}$ is used for the remaining cycles. The frequency is an average equal to:

$$f_{average} = \frac{32 \times f_{(DCO)} \times f_{(DCO+1)}}{MOD \times f_{(DCO)} + (32 - MOD) \times f_{(DCO+1)}}$$

DCO when using R_{OSC} (see Note 1)

PARAMETER	TEST CONDITIONS	V _{CC}	MIN	NOM	MAX	UNIT
f _{DCO} , DCO output frequency	R _{sel} = 4, DCO = 3, MOD = 0, DCOR = 1, T _A = 25°C	2.2 V	1.8±15%			MHz
		3 V	1.95±15%			MHz
D _t , Temperature drift	R _{sel} = 4, DCO = 3, MOD = 0, DCOR = 1	2.2 V/3 V	±0.1			%/°C
D _v , Drift with V _{CC} variation	R _{sel} = 4, DCO = 3, MOD = 0, DCOR = 1	2.2 V/3 V	10			%/V

NOTES: 1. R_{OSC} = 100kΩ. Metal film resistor, type 0257. 0.6 watt with 1% tolerance and T_K = ±50ppm/°C.

crystal oscillator, LFXT1

PARAMETER	TEST CONDITIONS	MIN	TYP	MAX	UNIT
C _{XIN} Input capacitance	XTS=0; LF mode selected. V _{CC} = 2.2 V / 3 V	12			pF
	XTS=1; XT1 mode selected. V _{CC} = 2.2 V / 3 V (see Note 1)	2			
C _{XOUT} Output capacitance	XTS=0; LF mode selected. V _{CC} = 2.2 V / 3 V	12			pF
	XTS=1; XT1 mode selected. V _{CC} = 2.2 V / 3 V (see Note 1)	2			
V _{IL}	Input levels at XIN V _{CC} = 2.2 V/3 V (see Note 2)	V _{SS}		0.2×V _{CC}	V
V _{IH}		0.8×V _{CC}		V _{CC}	

NOTES: 1. Requires external capacitors at both terminals. Values are specified by crystal manufacturers.
2. Applies only when using an external logic-level clock source. Not applicable when using a crystal or resonator.



electrical characteristics over recommended ranges of supply voltage and operating free-air temperature (unless otherwise noted) (continued)

Flash Memory

PARAMETER		TEST CONDITIONS	V _{CC}	MIN	NOM	MAX	UNIT
V _{CC(PGM/ERASE)}	Program and Erase supply voltage			2.7		3.6	V
f _{FTG}	Flash Timing Generator frequency			257		476	kHz
I _{PGM}	Supply current from V _{CC} during program		2.7 V/ 3.6 V		3	5	mA
I _{ERASE}	Supply current from V _{CC} during erase		2.7 V/ 3.6 V		3	7	mA
t _{CPT}	Cumulative program time	see Note 1	2.7 V/ 3.6 V			4	ms
t _{CMErase}	Cumulative mass erase time	see Note 2	2.7 V/ 3.6 V	200			ms
	Program/Erase endurance			10 ⁴	10 ⁵		cycles
t _{Retention}	Data retention duration	T _J = 25°C		100			years
t _{Word}	Word or byte program time	see Note 3			35		t _{FTG}
t _{Block, 0}	Block program time for 1 st byte or word				30		
t _{Block, 1-63}	Block program time for each additional byte or word				21		
t _{Block, End}	Block program end-sequence wait time				6		
t _{Mass Erase}	Mass erase time				5297		
t _{Seq Erase}	Segment erase time				4819		

- NOTES: 1. The cumulative program time must not be exceeded when writing to a 64-byte flash block. This parameter applies to all programming methods: individual word/byte write and block write modes.
 2. The mass erase duration generated by the flash timing generator is at least 11.1ms (= 5297x1/f_{FTG,max} = 5297x1/476kHz). To achieve the required cumulative mass erase time the Flash Controller's mass erase operation can be repeated until this time is met. (A worst case minimum of 19 cycles are required).
 3. These values are hardwired into the Flash Controller's state machine; t_{FTG} = 1/f_{FTG}.

JTAG Interface

PARAMETER		TEST CONDITIONS	V _{CC}	MIN	NOM	MAX	UNIT
f _{TCK}	TCK input frequency	see Note 1	2.2 V	0		5	MHz
			3 V	0		10	MHz
R _{Internal}	Internal pull-down resistance on TEST	see Note 2	2.2 V/ 3 V	25	60	90	kΩ

- NOTES: 1. f_{TCK} may be restricted to meet the timing requirements of the module selected.
 2. TEST pull-down resistor implemented in all versions.

JTAG Fuse (see Note 1)

PARAMETER		TEST CONDITIONS	V _{CC}	MIN	NOM	MAX	UNIT
V _{CC(FB)}	Supply voltage during fuse-blow condition	T _A = 25°C		2.5			V
V _{FB}	Voltage level on TEST for fuse-blow			6		7	V
I _{FB}	Supply current into TEST during fuse blow					100	mA
t _{FB}	Time to blow fuse					1	ms

- NOTES: 1. Once the fuse is blown, no further access to the MSP430 JTAG/Test and emulation features is possible. The JTAG block is switched to bypass mode.

MSP430x12x MIXED SIGNAL MICROCONTROLLER

SLAS312C – JULY 2001 – REVISED SEPTEMBER 2004

APPLICATION INFORMATION

input/output schematic

Port P1, P1.0 to P1.3, input/output with Schmitt-trigger

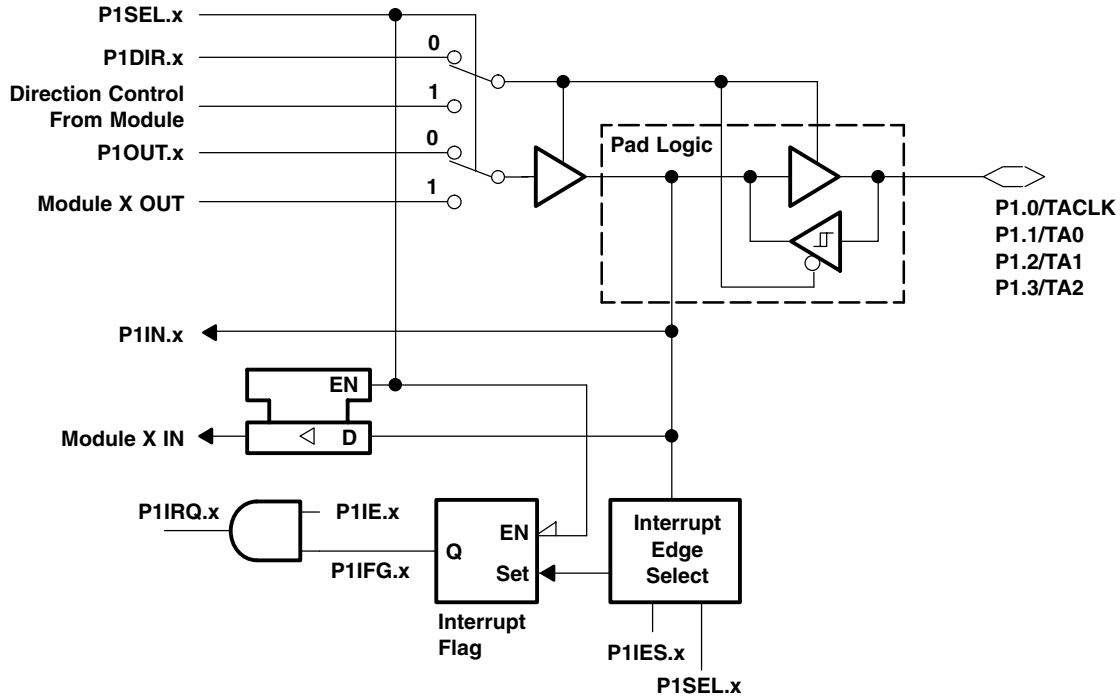

NOTE: x = Bit/identifier, 0 to 3 for port P1

P1Sel.0	P1DIR.0	P1DIR.0	P1OUT.0	V _{SS}	P1IN.0	TACLK [†]	P1IE.0	P1IFG.0	P1IES.0
P1Sel.1	P1DIR.1	P1DIR.1	P1OUT.1	Out0 signal [†]	P1IN.1	CCI0A [†]	P1IE.1	P1IFG.1	P1IES.1
P1Sel.2	P1DIR.2	P1DIR.2	P1OUT.2	Out1 signal [†]	P1IN.2	CCI1A [†]	P1IE.2	P1IFG.2	P1IES.2
P1Sel.3	P1DIR.3	P1DIR.3	P1OUT.3	Out2 signal [†]	P1IN.3	CCI2A [†]	P1IE.3	P1IFG.3	P1IES.3

[†] Signal from or to Timer_A

APPLICATION INFORMATION

input/output schematic (continued)

Port P1, P1.4 to P1.7, input/output with Schmitt-trigger and in-system access features

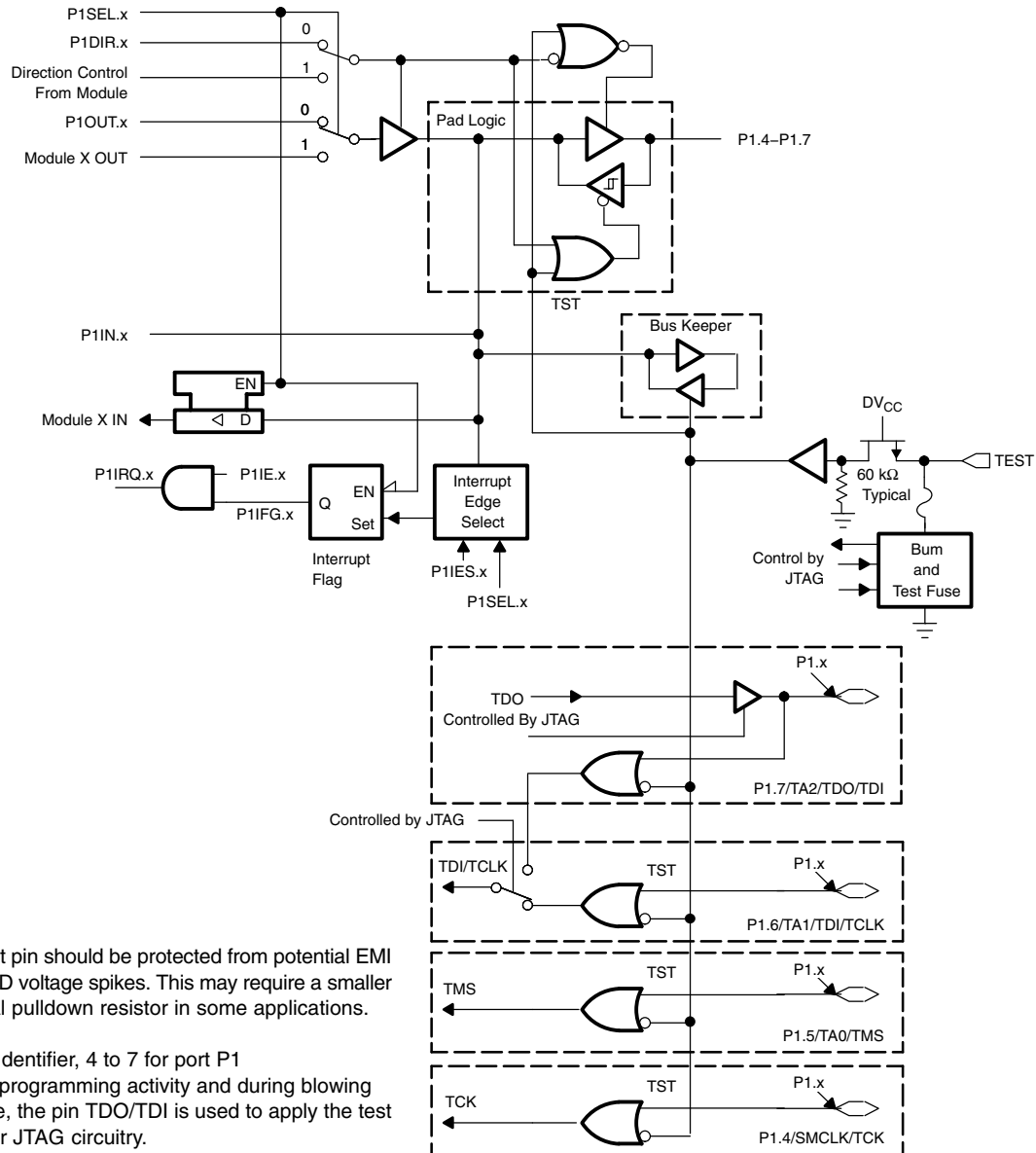

NOTE: The test pin should be protected from potential EMI and ESD voltage spikes. This may require a smaller external pull-down resistor in some applications.

x = Bit identifier, 4 to 7 for port P1
During programming activity and during blowing the fuse, the pin TDO/TDI is used to apply the test input for JTAG circuitry.

P1Sel.4	P1DIR.4	P1DIR.4	P1OUT.4	SMCLK	P1IN.4	unused	P1IE.4	P1IFG.4	P1IES.4
P1Sel.5	P1DIR.5	P1DIR.5	P1OUT.5	Out0 signal [†]	P1IN.5	unused	P1IE.5	P1IFG.5	P1IES.5
P1Sel.6	P1DIR.6	P1DIR.6	P1OUT.6	Out1 signal [†]	P1IN.6	unused	P1IE.6	P1IFG.6	P1IES.6
P1Sel.7	P1DIR.7	P1DIR.7	P1OUT.7	Out2 signal [†]	P1IN.7	unused	P1IE.7	P1IFG.7	P1IES.7

[†] Signal from or to Timer_A

MSP430x12x MIXED SIGNAL MICROCONTROLLER

SLAS312C – JULY 2001 – REVISED SEPTEMBER 2004

APPLICATION INFORMATION

input/output schematic (continued)

Port P2, P2.0 to P2.2, input/output with Schmitt-trigger

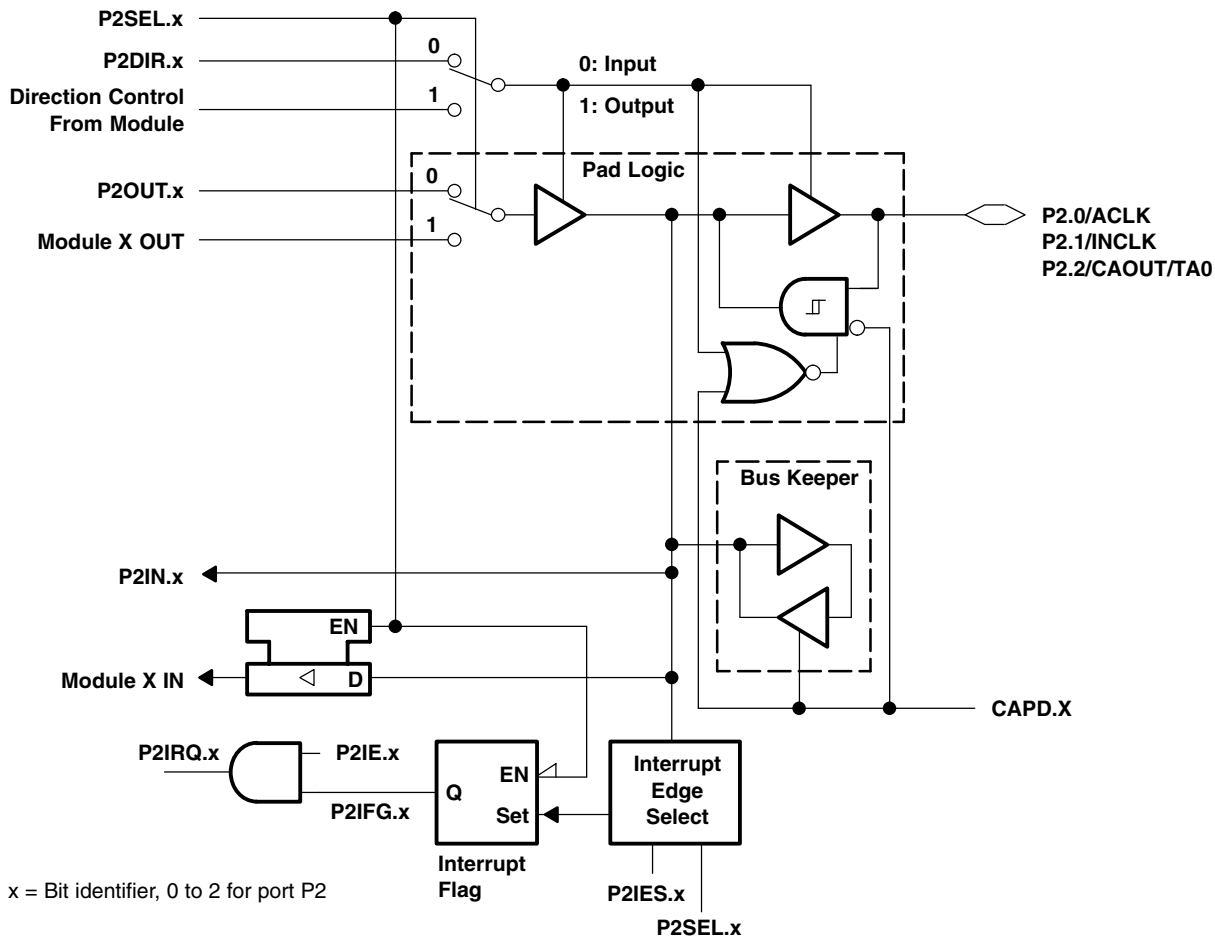

PnSel.x	PnDIR.x	DIRECTION CONTROL FROM MODULE	PnOUT.x	MODULE X OUT	PnIN.x	MODULE X IN	PnIE.x	PnIFG.x	PnIES.x
P2Sel.0	P2DIR.0	P2DIR.0	P2OUT.0	ACLK	P2IN.0	unused	P2IE.0	P2IFG.0	P1IES.0
P2Sel.1	P2DIR.1	P2DIR.1	P2OUT.1	V _{SS}	P2IN.1	INCLK [†]	P2IE.1	P2IFG.1	P1IES.1
P2Sel.2	P2DIR.2	P2DIR.2	P2OUT.2	CAOUT	P2IN.2	CCI0B [†]	P2IE.2	P2IFG.2	P1IES.2

[†] Signal from or to Timer_A

APPLICATION INFORMATION

input/output schematic (continued)

Port P2, P2.3 to P2.4, input/output with Schmitt-trigger

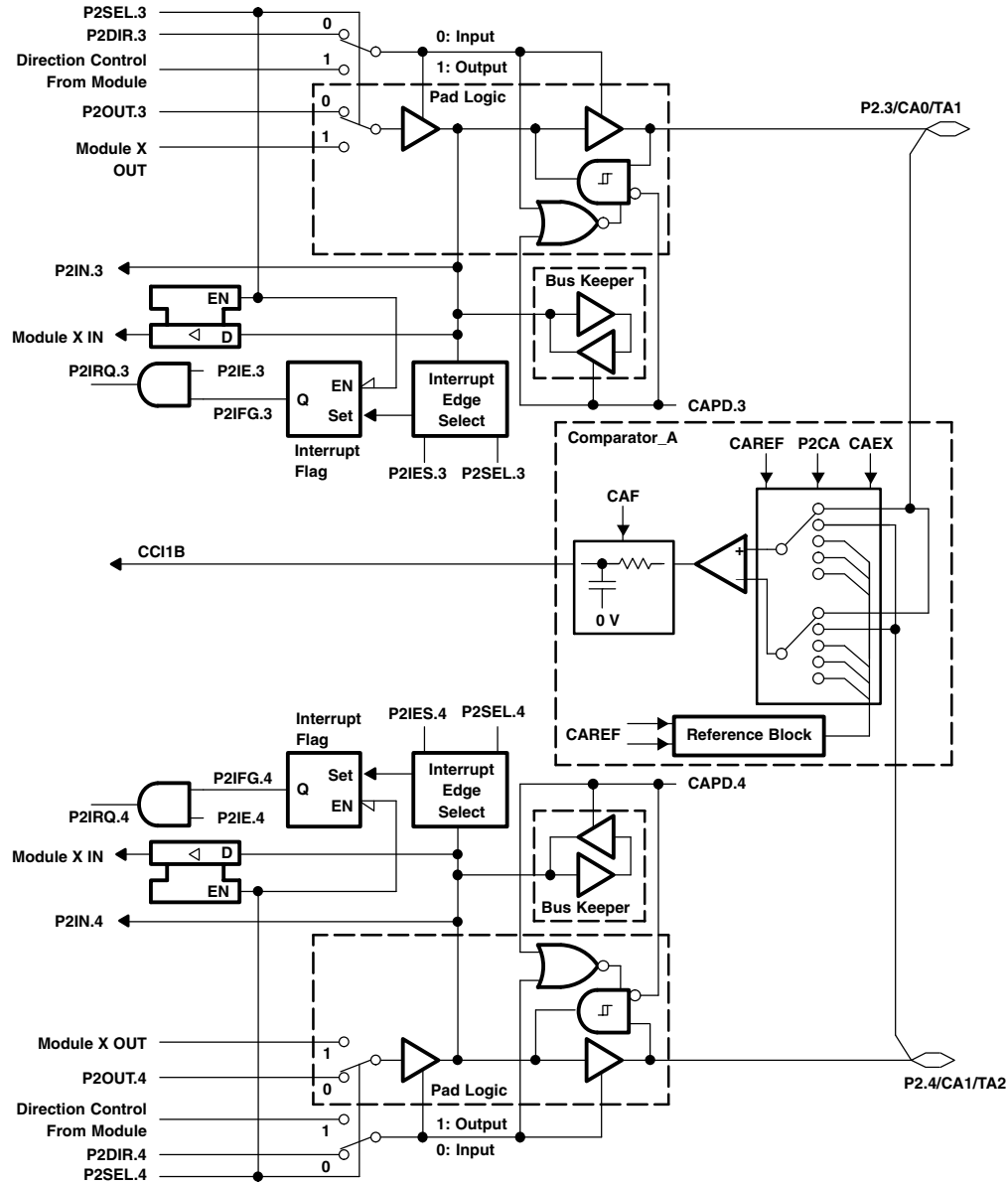

PnSel.x	PnDIR.x	DIRECTION CONTROL FROM MODULE	PnOUT.x	MODULE X OUT	PnIN.x	MODULE X IN	PnIE.x	PnIFG.x	PnIES.x
P2Sel.3	P2DIR.3	P2DIR.3	P2OUT.3	Out1 signal [†]	P2IN.3	unused	P2IE.3	P2IFG.3	P1IES.3
P2Sel.4	P2DIR.4	P2DIR.4	P2OUT.4	Out2 signal [†]	P2IN.4	unused	P2IE.4	P2IFG.4	P1IES.4

[†] Signal from Timer_A

MSP430x12x MIXED SIGNAL MICROCONTROLLER

SLAS312C – JULY 2001 – REVISED SEPTEMBER 2004

APPLICATION INFORMATION

input/output schematic (continued)

Port P2, P2.5, input/output with Schmitt-trigger and R_{osc} function for the Basic Clock module

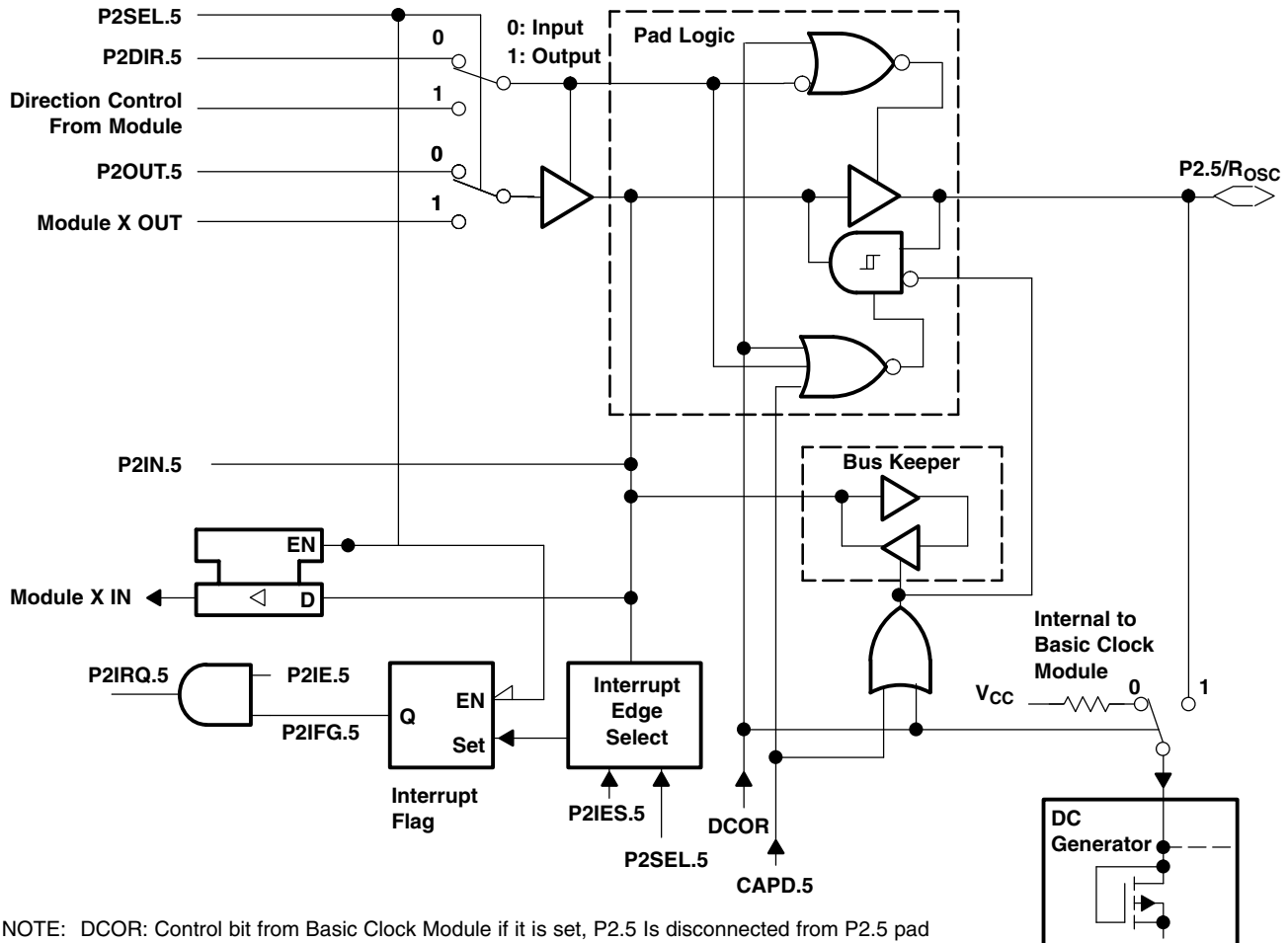

NOTE: DCOR: Control bit from Basic Clock Module if it is set, P2.5 is disconnected from P2.5 pad

PnSel.x	PnDIR.x	DIRECTION CONTROL FROM MODULE	PnOUT.x	MODULE X OUT	PnIN.x	MODULE X IN	PnIE.x	PnIFG.x	PnIES.x
P2Sel.5	P2DIR.5	P2DIR.5	P2OUT.5	V _{SS}	P2IN.5	unused	P2IE.5	P2IFG.5	P2IES.5

APPLICATION INFORMATION

input/output schematic (continued)

Port P2, unbonded bits P2.6 and P2.7

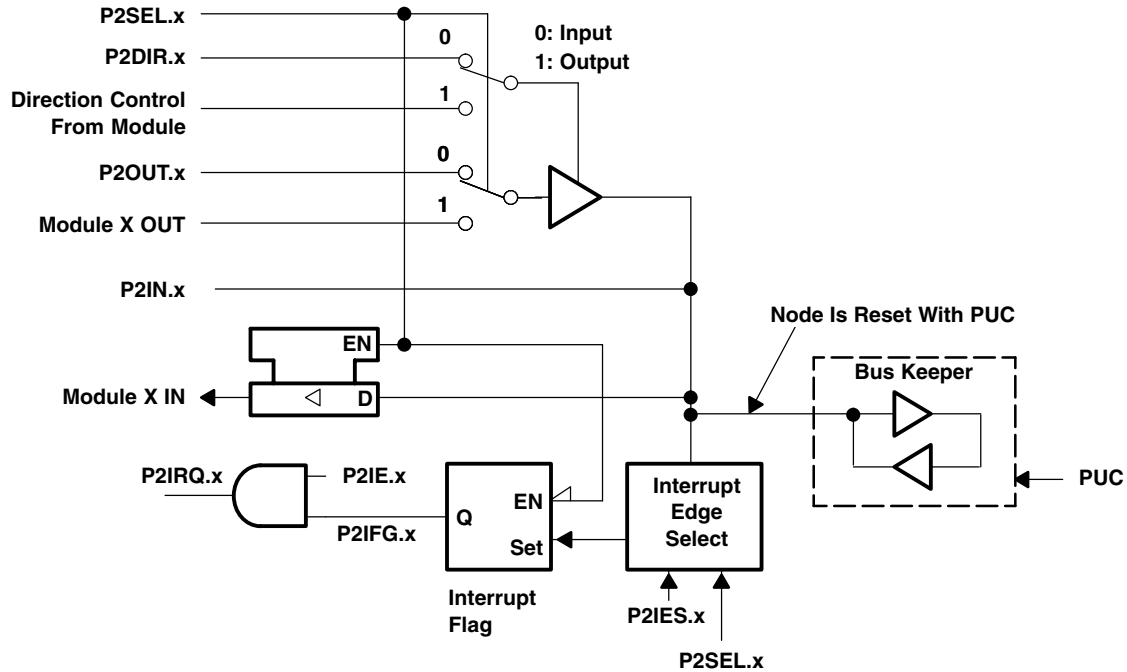

NOTE: x = Bit/identifier, 6 to 7 for port P2 without external pins

P2Sel.x	P2DIR.x	DIRECTION-CONTROL FROM MODULE	P2OUT.x	MODULE X OUT	P2IN.x	MODULE X IN	P2IE.x	P2IFG.x	P2IES.x
P2Sel.6	P2DIR.6	P2DIR.6	P2OUT.6	V _{SS}	P2IN.6	unused	P2IE.6	P2IFG.6	P2IES.6
P2Sel.7	P2DIR.7	P2DIR.7	P2OUT.7	V _{SS}	P2IN.7	unused	P2IE.7	P2IFG.7	P2IES.7

NOTE: Unbonded bits 6 and 7 of port P2 can be used as interrupt flags. Only software can affect the interrupt flags. They work as software interrupts.

MSP430x12x MIXED SIGNAL MICROCONTROLLER

SLAS312C – JULY 2001 – REVISED SEPTEMBER 2004

APPLICATION INFORMATION

input/output schematic (continued)

port P3, P3.0 and P3.4 to P3.7, input/output with Schmitt-trigger

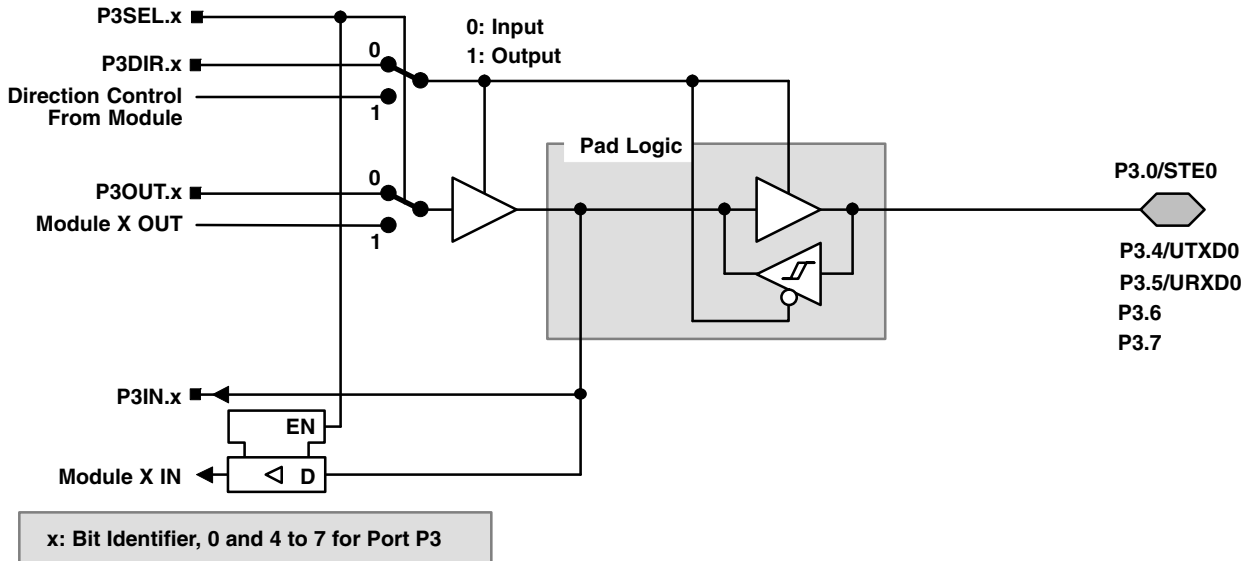

PnSel.x	PnDIR.x	DIRECTION CONTROL FROM MODULE	PnOUT.x	MODULE X OUT	PnIN.x	MODULE X IN
P3Sel.0	P3DIR.0	V _{SS}	P3OUT.0	V _{SS}	P3IN.0	STE0
P3Sel.4	P3DIR.4	V _{CC}	P3OUT.4	UTXD0 [†]	P3IN.4	Unused
P3Sel.5	P3DIR.5	V _{SS}	P3OUT.5	V _{SS}	P3IN.5	URXD0 [‡]
P3Sel.6	P3DIR.6	V _{SS}	P3OUT.6	V _{SS}	P3IN.6	Unused
P3Sel.7	P3DIR.7	V _{SS}	P3OUT.7	V _{SS}	P3IN.7	Unused

[†] Output from USART0 module

[‡] Input to USART0 module

port P3, P3.1, input/output with Schmitt-trigger

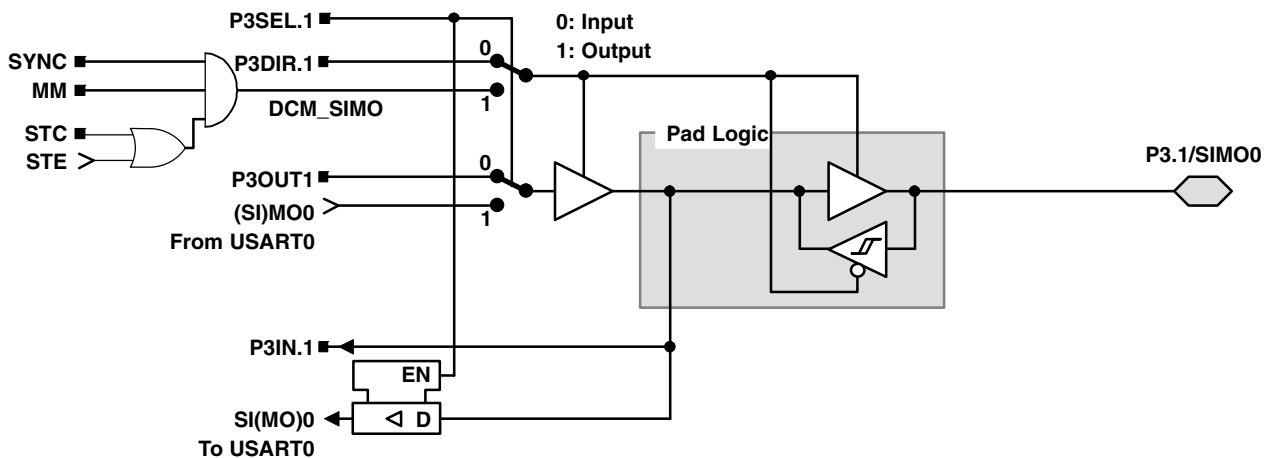

APPLICATION INFORMATION

input/output schematic (continued)

port P3, P3.2, input/output with Schmitt-trigger

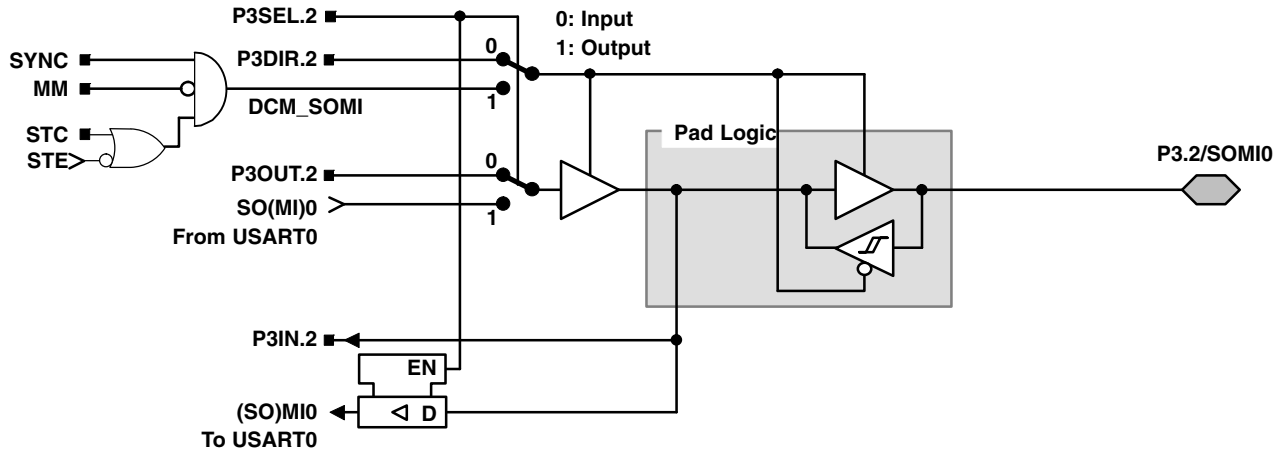

port P3, P3.3, input/output with Schmitt-trigger

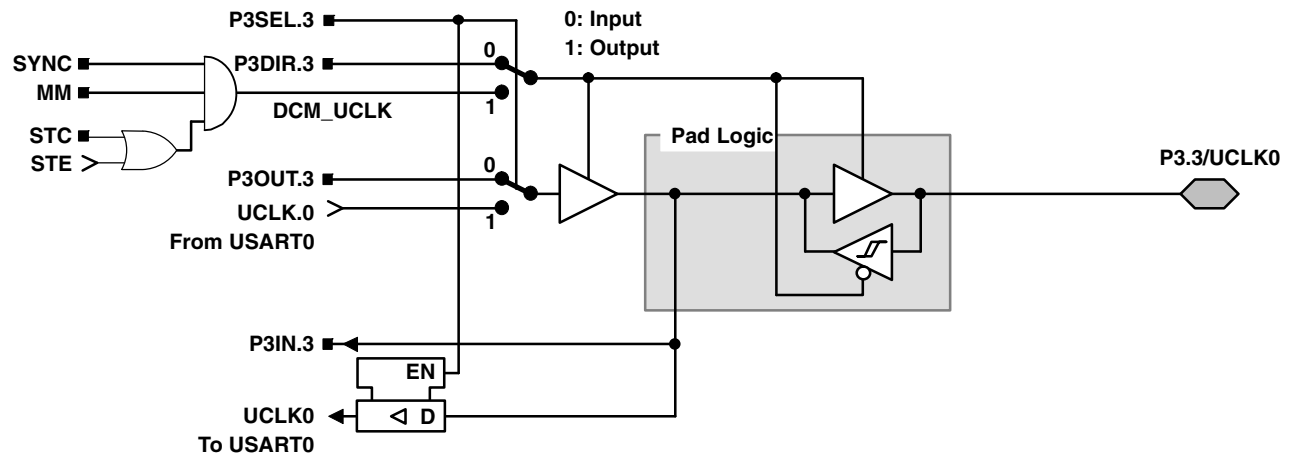

NOTE: UART mode: The UART clock can only be an input. If UART mode and UART function are selected, the P3.3/UCLK0 is always an input.
 SPI, slave mode: The clock applied to UCLK0 is used to shift data in and out.
 SPI, master mode: The clock to shift data in and out is supplied to connected devices on pin P3.3/UCLK0 (in slave mode).

APPLICATION INFORMATION

JTAG fuse check mode

MSP430 devices that have the fuse on the TEST terminal have a fuse check mode that tests the continuity of the fuse the first time the JTAG port is accessed after a power-on reset (POR). When activated, a fuse check current, a fuse check current, I_{TF} , of 1 mA at 3 V, 2.5 mA at 5 V can flow from from the TEST pin to ground if the fuse is not burned. Care must be taken to avoid accidentally activating the fuse check mode and increasing overall system power consumption.

When the TEST pin is taken back low after a test or programming session, the fuse check mode and sense currents are terminated.

Activation of the fuse check mode occurs with the first negative edge on the TMS pin after power up or if the TMS is being held low during power up. The second positive edge on the TMS pin deactivates the fuse check mode. After deactivation, the fuse check mode remains inactive until another POR occurs. After each POR the fuse check mode has the potential to be activated.

The fuse check current will only flow when the fuse check mode is active and the TMS pin is in a low state (see Figure 13). Therefore, the additional current flow can be prevented by holding the TMS pin high (default condition).

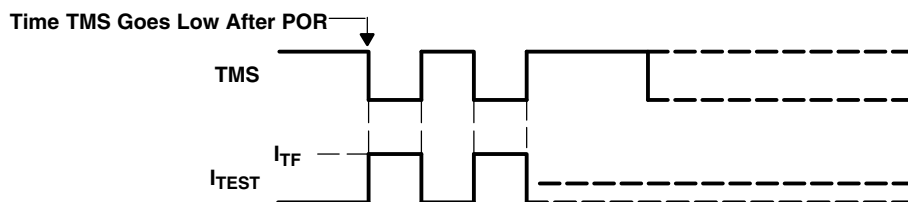

Figure 13. Fuse Check Mode Current, MSP430F12x

NOTE:

The CODE and RAM data protection is ensured if the JTAG fuse is blown and the 256-bit bootloader access key is used. Also see the *bootstrap loader* section for more information.

PACKAGING INFORMATION

Orderable Device	Status (1)	Package Type	Package Drawing	Pins	Package Qty	Eco Plan (2)	Lead/Ball Finish (6)	MSL Peak Temp (3)	Op Temp (°C)	Device Marking (4/5)	Samples
MSP430A012IDW	ACTIVE	SOIC	DW	28	20	Green (RoHS & no Sb/Br)	CU NIPDAU	Level-1-260C-UNLIM	-40 to 85	M430F123	Samples
MSP430A012IDWR	ACTIVE	SOIC	DW	28	1000	Green (RoHS & no Sb/Br)	CU NIPDAU	Level-1-260C-UNLIM	-40 to 85	M430F123	Samples
MSP430A052IPW	ACTIVE	TSSOP	PW	28	50	Green (RoHS & no Sb/Br)	CU NIPDAU	Level-1-260C-UNLIM	-40 to 85	M430F123	Samples
MSP430A052IPWR	ACTIVE	TSSOP	PW	28	2000	Green (RoHS & no Sb/Br)	CU NIPDAU	Level-1-260C-UNLIM	-40 to 85	M430F123	Samples
MSP430F122IDW	ACTIVE	SOIC	DW	28	20	Green (RoHS & no Sb/Br)	CU NIPDAU	Level-1-260C-UNLIM	-40 to 85	M430F122	Samples
MSP430F122IDWR	ACTIVE	SOIC	DW	28	1000	Green (RoHS & no Sb/Br)	CU NIPDAU	Level-1-260C-UNLIM	-40 to 85	M430F122	Samples
MSP430F122IPW	ACTIVE	TSSOP	PW	28	50	Green (RoHS & no Sb/Br)	CU NIPDAU	Level-1-260C-UNLIM	-40 to 85	M430F122	Samples
MSP430F122IPWR	ACTIVE	TSSOP	PW	28	2000	Green (RoHS & no Sb/Br)	CU NIPDAU	Level-1-260C-UNLIM	-40 to 85	M430F122	Samples
MSP430F122IRHBR	ACTIVE	VQFN	RHB	32	3000	Green (RoHS & no Sb/Br)	CU NIPDAU	Level-2-260C-1 YEAR	-40 to 85	MSP430 F122	Samples
MSP430F122IRHBT	ACTIVE	VQFN	RHB	32	250	Green (RoHS & no Sb/Br)	CU NIPDAU	Level-2-260C-1 YEAR	-40 to 85	MSP430 F122	Samples
MSP430F123IDW	ACTIVE	SOIC	DW	28	20	Green (RoHS & no Sb/Br)	CU NIPDAU	Level-1-260C-UNLIM	-40 to 85	M430F123	Samples
MSP430F123IDWR	ACTIVE	SOIC	DW	28	1000	Green (RoHS & no Sb/Br)	CU NIPDAU	Level-1-260C-UNLIM	-40 to 85	M430F123	Samples
MSP430F123IPW	ACTIVE	TSSOP	PW	28	50	Green (RoHS & no Sb/Br)	CU NIPDAU	Level-1-260C-UNLIM	-40 to 85	M430F123	Samples
MSP430F123IPWR	ACTIVE	TSSOP	PW	28	2000	Green (RoHS & no Sb/Br)	CU NIPDAU	Level-1-260C-UNLIM	-40 to 85	M430F123	Samples
MSP430F123IPWR-HYD	ACTIVE	TSSOP	PW	28	2000	Green (RoHS & no Sb/Br)	CU NIPDAU	Level-1-260C-UNLIM	-40 to 85	M430F123	Samples
MSP430F123IRHBR	ACTIVE	VQFN	RHB	32	3000	Green (RoHS & no Sb/Br)	CU NIPDAU	Level-2-260C-1 YEAR	-40 to 85	MSP430 F123	Samples
MSP430F123IRHBT	ACTIVE	VQFN	RHB	32	250	Green (RoHS & no Sb/Br)	CU NIPDAU	Level-2-260C-1 YEAR	-40 to 85	MSP430 F123	Samples

(1) The marketing status values are defined as follows:

ACTIVE: Product device recommended for new designs.

LIFEBUY: TI has announced that the device will be discontinued, and a lifetime-buy period is in effect.

NRND: Not recommended for new designs. Device is in production to support existing customers, but TI does not recommend using this part in a new design.

PREVIEW: Device has been announced but is not in production. Samples may or may not be available.

OBSOLETE: TI has discontinued the production of the device.

(2) Eco Plan - The planned eco-friendly classification: Pb-Free (RoHS), Pb-Free (RoHS Exempt), or Green (RoHS & no Sb/Br) - please check <http://www.ti.com/productcontent> for the latest availability information and additional product content details.

TBD: The Pb-Free/Green conversion plan has not been defined.

Pb-Free (RoHS): TI's terms "Lead-Free" or "Pb-Free" mean semiconductor products that are compatible with the current RoHS requirements for all 6 substances, including the requirement that lead not exceed 0.1% by weight in homogeneous materials. Where designed to be soldered at high temperatures, TI Pb-Free products are suitable for use in specified lead-free processes.

Pb-Free (RoHS Exempt): This component has a RoHS exemption for either 1) lead-based flip-chip solder bumps used between the die and package, or 2) lead-based die adhesive used between the die and leadframe. The component is otherwise considered Pb-Free (RoHS compatible) as defined above.

Green (RoHS & no Sb/Br): TI defines "Green" to mean Pb-Free (RoHS compatible), and free of Bromine (Br) and Antimony (Sb) based flame retardants (Br or Sb do not exceed 0.1% by weight in homogeneous material)

(3) MSL, Peak Temp. - The Moisture Sensitivity Level rating according to the JEDEC industry standard classifications, and peak solder temperature.

(4) There may be additional marking, which relates to the logo, the lot trace code information, or the environmental category on the device.

(5) Multiple Device Markings will be inside parentheses. Only one Device Marking contained in parentheses and separated by a "~" will appear on a device. If a line is indented then it is a continuation of the previous line and the two combined represent the entire Device Marking for that device.

(6) Lead/Ball Finish - Orderable Devices may have multiple material finish options. Finish options are separated by a vertical ruled line. Lead/Ball Finish values may wrap to two lines if the finish value exceeds the maximum column width.

Important Information and Disclaimer: The information provided on this page represents TI's knowledge and belief as of the date that it is provided. TI bases its knowledge and belief on information provided by third parties, and makes no representation or warranty as to the accuracy of such information. Efforts are underway to better integrate information from third parties. TI has taken and continues to take reasonable steps to provide representative and accurate information but may not have conducted destructive testing or chemical analysis on incoming materials and chemicals. TI and TI suppliers consider certain information to be proprietary, and thus CAS numbers and other limited information may not be available for release.

In no event shall TI's liability arising out of such information exceed the total purchase price of the TI part(s) at issue in this document sold by TI to Customer on an annual basis.

TAPE AND REEL INFORMATION



QUADRANT ASSIGNMENTS FOR PIN 1 ORIENTATION IN TAPE



*All dimensions are nominal

Device	Package Type	Package Drawing	Pins	SPQ	Reel Diameter (mm)	Reel Width W1 (mm)	A0 (mm)	B0 (mm)	K0 (mm)	P1 (mm)	W (mm)	Pin1 Quadrant
MSP430F122IDWR	SOIC	DW	28	1000	330.0	32.4	11.35	18.67	3.1	16.0	32.0	Q1
MSP430F122IPWR	TSSOP	PW	28	2000	330.0	16.4	6.9	10.2	1.8	12.0	16.0	Q1
MSP430F122IRHBR	VQFN	RHB	32	3000	330.0	12.4	5.3	5.3	1.5	8.0	12.0	Q2
MSP430F122IRHBT	VQFN	RHB	32	250	180.0	12.4	5.3	5.3	1.5	8.0	12.0	Q2
MSP430F123IDWR	SOIC	DW	28	1000	330.0	32.4	11.35	18.67	3.1	16.0	32.0	Q1
MSP430F123IPWR	TSSOP	PW	28	2000	330.0	16.4	6.9	10.2	1.8	12.0	16.0	Q1
MSP430F123IRHBR	VQFN	RHB	32	3000	330.0	12.4	5.3	5.3	1.5	8.0	12.0	Q2
MSP430F123IRHBT	VQFN	RHB	32	250	180.0	12.4	5.3	5.3	1.5	8.0	12.0	Q2

TAPE AND REEL BOX DIMENSIONS

*All dimensions are nominal

Device	Package Type	Package Drawing	Pins	SPQ	Length (mm)	Width (mm)	Height (mm)
MSP430F122IDWR	SOIC	DW	28	1000	367.0	367.0	55.0
MSP430F122IPWR	TSSOP	PW	28	2000	367.0	367.0	38.0
MSP430F122IRHBR	VQFN	RHB	32	3000	367.0	367.0	35.0
MSP430F122IRHBT	VQFN	RHB	32	250	210.0	185.0	35.0
MSP430F123IDWR	SOIC	DW	28	1000	367.0	367.0	55.0
MSP430F123IPWR	TSSOP	PW	28	2000	367.0	367.0	38.0
MSP430F123IRHBR	VQFN	RHB	32	3000	367.0	367.0	35.0
MSP430F123IRHBT	VQFN	RHB	32	250	210.0	185.0	35.0

DW (R-PDSO-G28)

PLASTIC SMALL OUTLINE

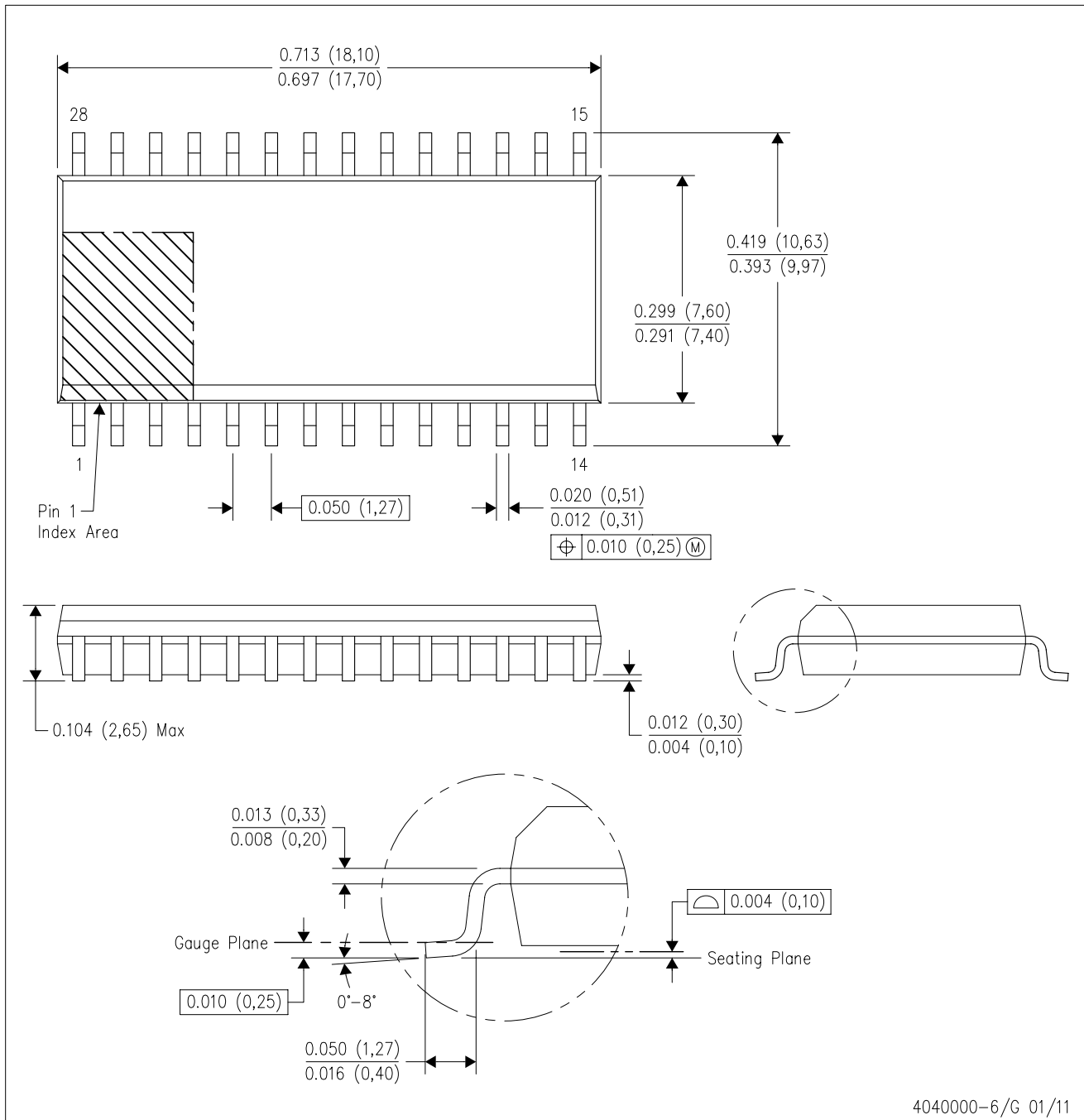

4040000-6/G 01/11

- NOTES:
- All linear dimensions are in inches (millimeters). Dimensioning and tolerancing per ASME Y14.5M-1994.
 - This drawing is subject to change without notice.
 - Body dimensions do not include mold flash or protrusion not to exceed 0.006 (0,15).
 - Falls within JEDEC MS-013 variation AE.

DW (R-PDSO-G28)

PLASTIC SMALL OUTLINE

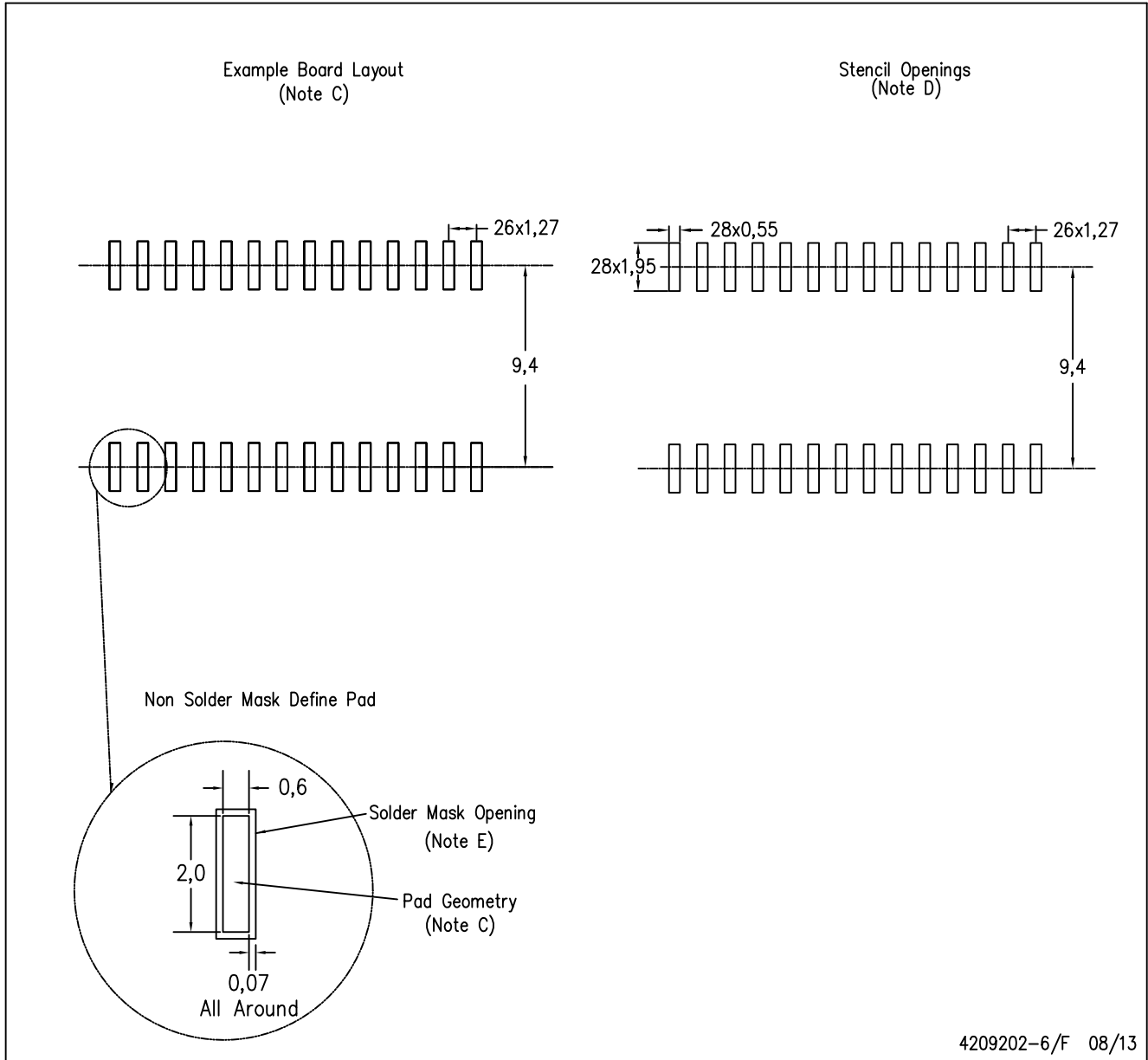

4209202-6/F 08/13

- NOTES:
- A. All linear dimensions are in millimeters.
 - B. This drawing is subject to change without notice.
 - C. Refer to IPC7351 for alternate board design.
 - D. Laser cutting apertures with trapezoidal walls and also rounding corners will offer better paste release. Customers should contact their board assembly site for stencil design recommendations. Refer to IPC-7525
 - E. Customers should contact their board fabrication site for solder mask tolerances between and around signal pads.

MECHANICAL DATA

RHB (S-PVQFN-N32)

PLASTIC QUAD FLATPACK NO-LEAD

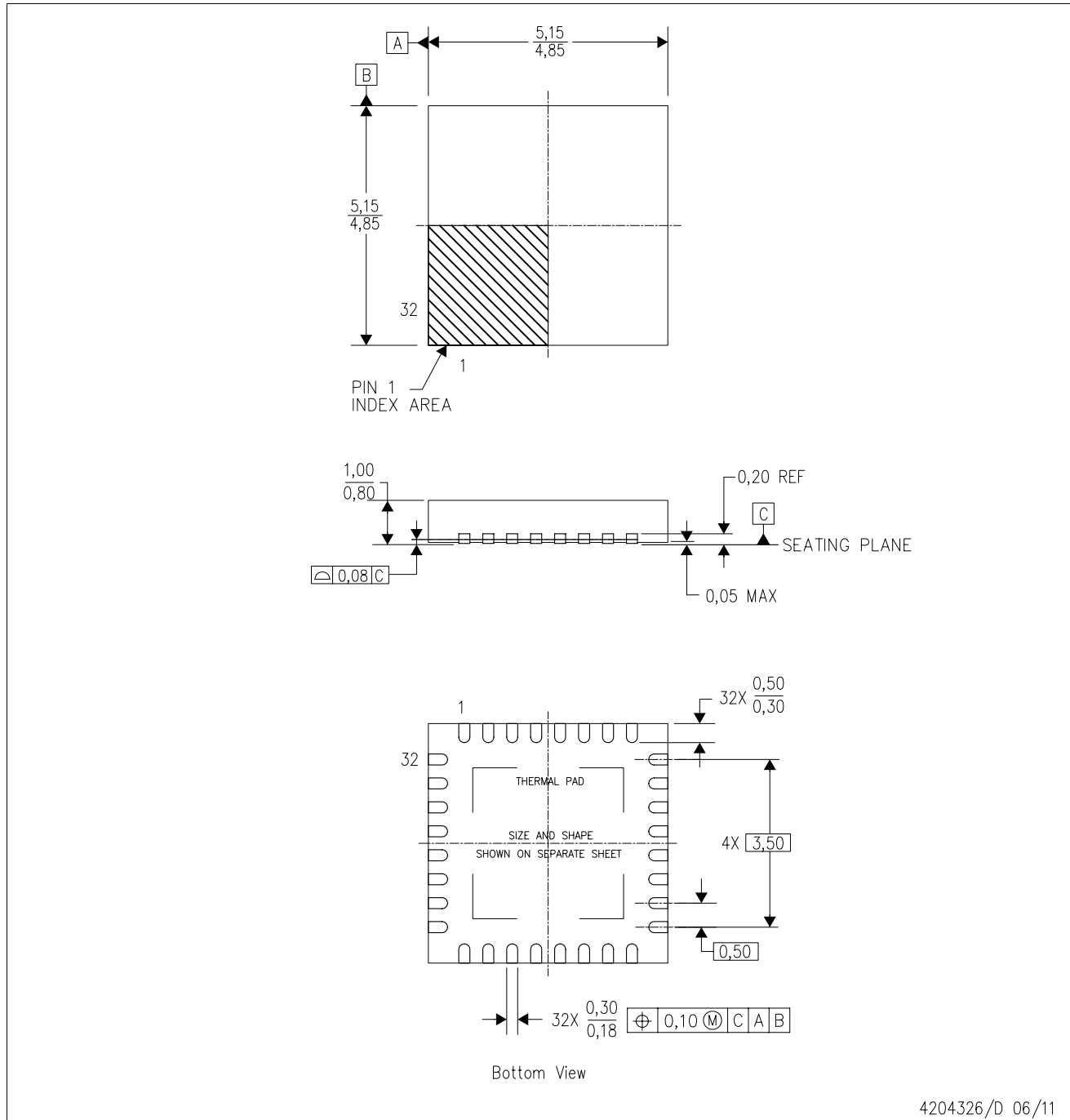

4204326/D 06/11

- NOTES:
- All linear dimensions are in millimeters. Dimensioning and tolerancing per ASME Y14.5M-1994.
 - This drawing is subject to change without notice.
 - QFN (Quad Flatpack No-Lead) Package configuration.
 - The package thermal pad must be soldered to the board for thermal and mechanical performance.
 - See the additional figure in the Product Data Sheet for details regarding the exposed thermal pad features and dimensions.
 - Falls within JEDEC MO-220.

THERMAL INFORMATION

This package incorporates an exposed thermal pad that is designed to be attached directly to an external heatsink. The thermal pad must be soldered directly to the printed circuit board (PCB). After soldering, the PCB can be used as a heatsink. In addition, through the use of thermal vias, the thermal pad can be attached directly to the appropriate copper plane shown in the electrical schematic for the device, or alternatively, can be attached to a special heatsink structure designed into the PCB. This design optimizes the heat transfer from the integrated circuit (IC).

For information on the Quad Flatpack No-Lead (QFN) package and its advantages, refer to Application Report, QFN/SON PCB Attachment, Texas Instruments Literature No. SLUA271. This document is available at www.ti.com.

The exposed thermal pad dimensions for this package are shown in the following illustration.

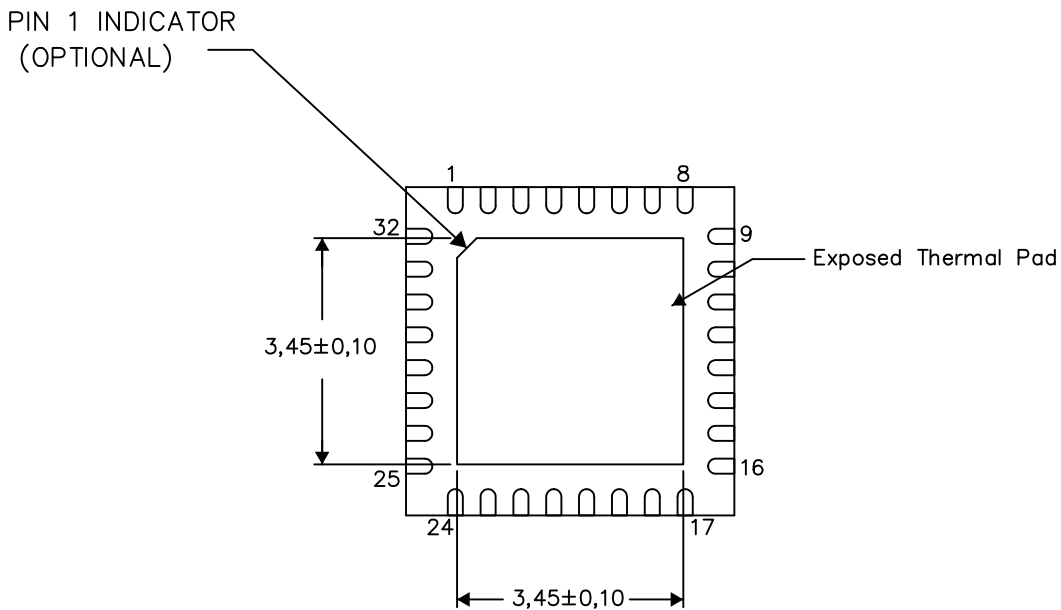

Bottom View

Exposed Thermal Pad Dimensions

4206356-2/AC 05/15

NOTE: A. All linear dimensions are in millimeters

RHB (S-PVQFN-N32)

PLASTIC QUAD FLATPACK NO-LEAD

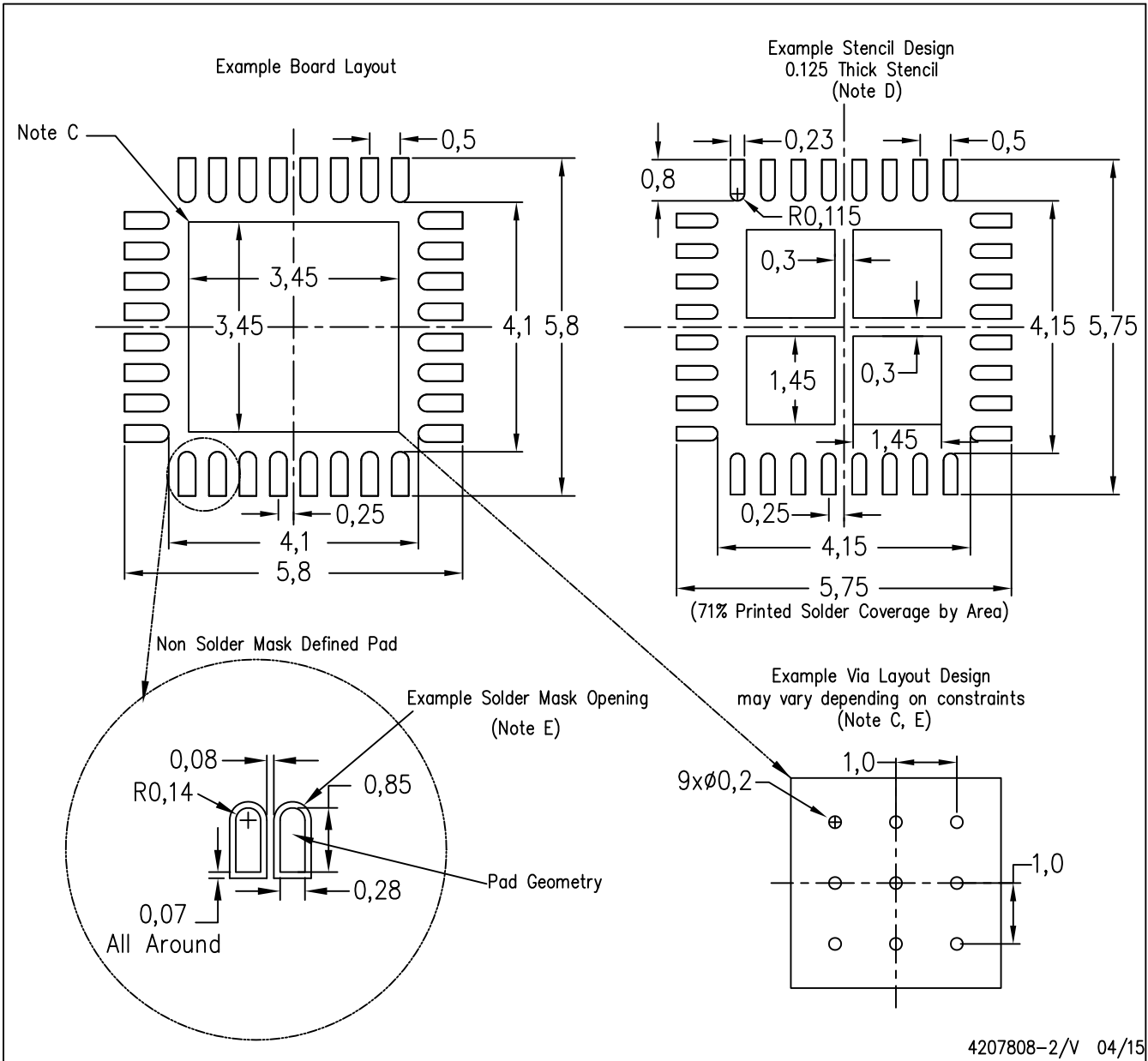

- NOTES:
- All linear dimensions are in millimeters.
 - This drawing is subject to change without notice.
 - This package is designed to be soldered to a thermal pad on the board. Refer to Application Note, Quad Flat-Pack Packages, Texas Instruments Literature No. SLUA271, and also the Product Data Sheets for specific thermal information, via requirements, and recommended board layout. These documents are available at www.ti.com <<http://www.ti.com>>.
 - Laser cutting apertures with trapezoidal walls and also rounding corners will offer better paste release. Customers should contact their board assembly site for stencil design recommendations. Refer to IPC 7525 for stencil design considerations.
 - Customers should contact their board fabrication site for recommended solder mask tolerances and via tenting recommendations for any larger diameter vias placed in the thermal pad.



MECHANICAL DATA

PW (R-PDSO-G28)

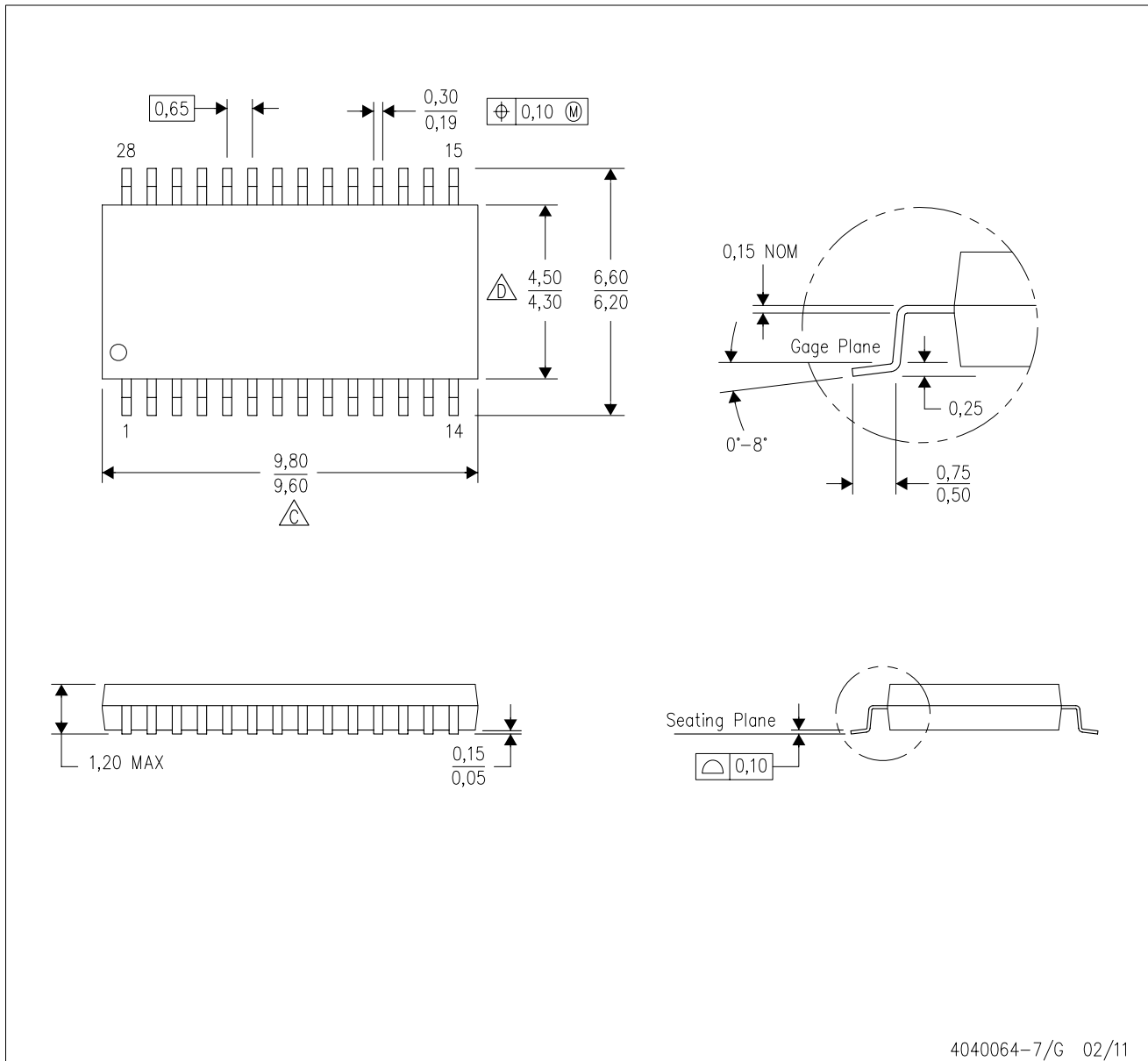
PLASTIC SMALL OUTLINE



4040064-7/G 02/11

- NOTES:
- A. All linear dimensions are in millimeters. Dimensioning and tolerancing per ASME Y14.5M-1994.
 - B. This drawing is subject to change without notice.
 -  C. Body length does not include mold flash, protrusions, or gate burrs. Mold flash, protrusions, or gate burrs shall not exceed 0,15 each side.
 -  D. Body width does not include interlead flash. Interlead flash shall not exceed 0,25 each side.
 - E. Falls within JEDEC MO-153

PW (R-PDSO-G28)

PLASTIC SMALL OUTLINE

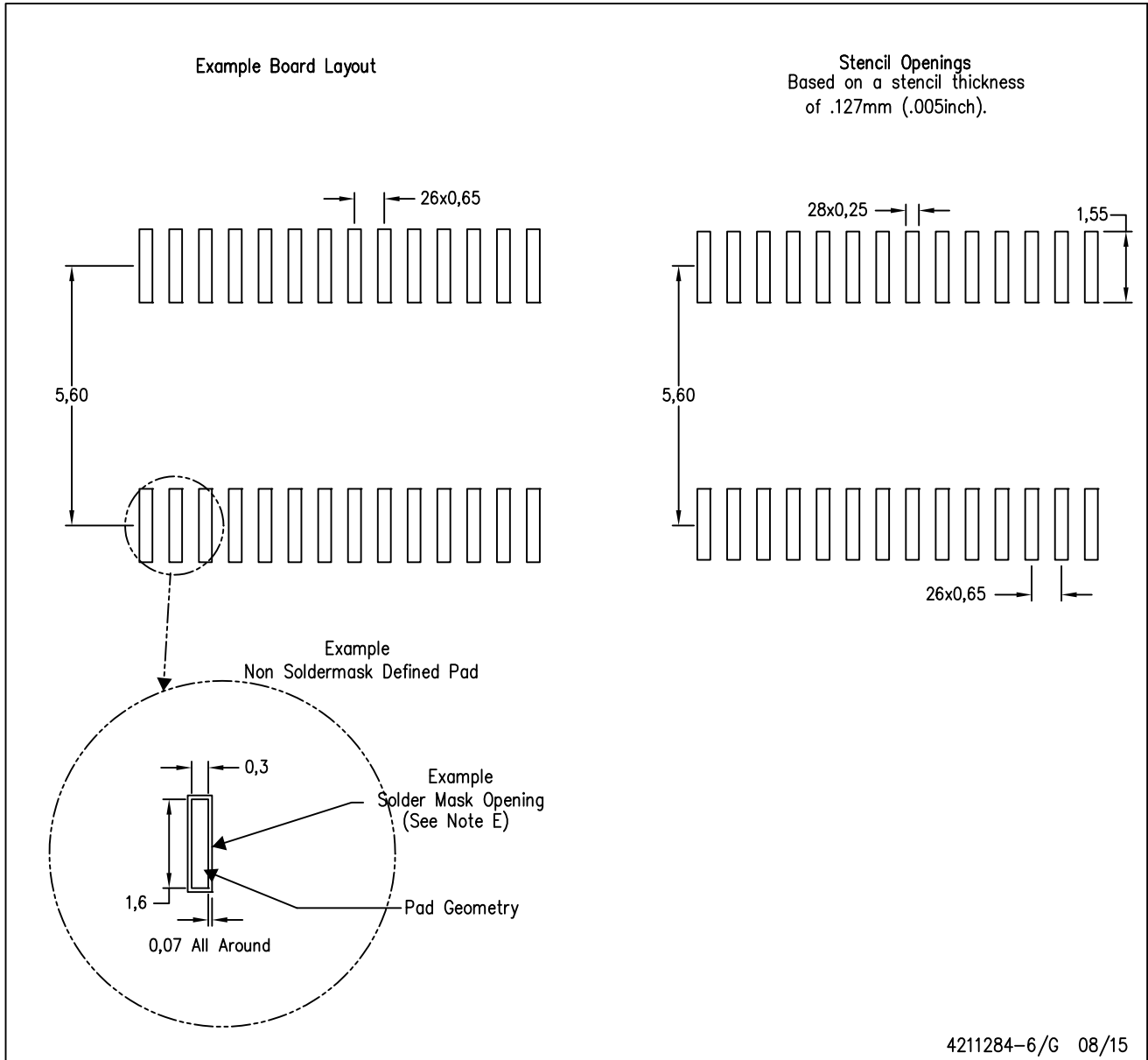

- NOTES:
- All linear dimensions are in millimeters.
 - This drawing is subject to change without notice.
 - Publication IPC-7351 is recommended for alternate design.
 - Laser cutting apertures with trapezoidal walls and also rounding corners will offer better paste release. Customers should contact their board assembly site for stencil design recommendations. Refer to IPC-7525 for other stencil recommendations.
 - Customers should contact their board fabrication site for solder mask tolerances between and around signal pads.

IMPORTANT NOTICE

Texas Instruments Incorporated (TI) reserves the right to make corrections, enhancements, improvements and other changes to its semiconductor products and services per JESD46, latest issue, and to discontinue any product or service per JESD48, latest issue. Buyers should obtain the latest relevant information before placing orders and should verify that such information is current and complete.

TI's published terms of sale for semiconductor products (<http://www.ti.com/sc/docs/stdterms.htm>) apply to the sale of packaged integrated circuit products that TI has qualified and released to market. Additional terms may apply to the use or sale of other types of TI products and services.

Reproduction of significant portions of TI information in TI data sheets is permissible only if reproduction is without alteration and is accompanied by all associated warranties, conditions, limitations, and notices. TI is not responsible or liable for such reproduced documentation. Information of third parties may be subject to additional restrictions. Resale of TI products or services with statements different from or beyond the parameters stated by TI for that product or service voids all express and any implied warranties for the associated TI product or service and is an unfair and deceptive business practice. TI is not responsible or liable for any such statements.

Buyers and others who are developing systems that incorporate TI products (collectively, "Designers") understand and agree that Designers remain responsible for using their independent analysis, evaluation and judgment in designing their applications and that Designers have full and exclusive responsibility to assure the safety of Designers' applications and compliance of their applications (and of all TI products used in or for Designers' applications) with all applicable regulations, laws and other applicable requirements. Designer represents that, with respect to their applications, Designer has all the necessary expertise to create and implement safeguards that (1) anticipate dangerous consequences of failures, (2) monitor failures and their consequences, and (3) lessen the likelihood of failures that might cause harm and take appropriate actions. Designer agrees that prior to using or distributing any applications that include TI products, Designer will thoroughly test such applications and the functionality of such TI products as used in such applications.

TI's provision of technical, application or other design advice, quality characterization, reliability data or other services or information, including, but not limited to, reference designs and materials relating to evaluation modules, (collectively, "TI Resources") are intended to assist designers who are developing applications that incorporate TI products; by downloading, accessing or using TI Resources in any way, Designer (individually or, if Designer is acting on behalf of a company, Designer's company) agrees to use any particular TI Resource solely for this purpose and subject to the terms of this Notice.

TI's provision of TI Resources does not expand or otherwise alter TI's applicable published warranties or warranty disclaimers for TI products, and no additional obligations or liabilities arise from TI providing such TI Resources. TI reserves the right to make corrections, enhancements, improvements and other changes to its TI Resources. TI has not conducted any testing other than that specifically described in the published documentation for a particular TI Resource.

Designer is authorized to use, copy and modify any individual TI Resource only in connection with the development of applications that include the TI product(s) identified in such TI Resource. NO OTHER LICENSE, EXPRESS OR IMPLIED, BY ESTOPPEL OR OTHERWISE TO ANY OTHER TI INTELLECTUAL PROPERTY RIGHT, AND NO LICENSE TO ANY TECHNOLOGY OR INTELLECTUAL PROPERTY RIGHT OF TI OR ANY THIRD PARTY IS GRANTED HEREIN, including but not limited to any patent right, copyright, mask work right, or other intellectual property right relating to any combination, machine, or process in which TI products or services are used. Information regarding or referencing third-party products or services does not constitute a license to use such products or services, or a warranty or endorsement thereof. Use of TI Resources may require a license from a third party under the patents or other intellectual property of the third party, or a license from TI under the patents or other intellectual property of TI.

TI RESOURCES ARE PROVIDED "AS IS" AND WITH ALL FAULTS. TI DISCLAIMS ALL OTHER WARRANTIES OR REPRESENTATIONS, EXPRESS OR IMPLIED, REGARDING RESOURCES OR USE THEREOF, INCLUDING BUT NOT LIMITED TO ACCURACY OR COMPLETENESS, TITLE, ANY EPIDEMIC FAILURE WARRANTY AND ANY IMPLIED WARRANTIES OF MERCHANTABILITY, FITNESS FOR A PARTICULAR PURPOSE, AND NON-INFRINGEMENT OF ANY THIRD PARTY INTELLECTUAL PROPERTY RIGHTS. TI SHALL NOT BE LIABLE FOR AND SHALL NOT DEFEND OR INDEMNIFY DESIGNER AGAINST ANY CLAIM, INCLUDING BUT NOT LIMITED TO ANY INFRINGEMENT CLAIM THAT RELATES TO OR IS BASED ON ANY COMBINATION OF PRODUCTS EVEN IF DESCRIBED IN TI RESOURCES OR OTHERWISE. IN NO EVENT SHALL TI BE LIABLE FOR ANY ACTUAL, DIRECT, SPECIAL, COLLATERAL, INDIRECT, PUNITIVE, INCIDENTAL, CONSEQUENTIAL OR EXEMPLARY DAMAGES IN CONNECTION WITH OR ARISING OUT OF TI RESOURCES OR USE THEREOF, AND REGARDLESS OF WHETHER TI HAS BEEN ADVISED OF THE POSSIBILITY OF SUCH DAMAGES.

Unless TI has explicitly designated an individual product as meeting the requirements of a particular industry standard (e.g., ISO/TS 16949 and ISO 26262), TI is not responsible for any failure to meet such industry standard requirements.

Where TI specifically promotes products as facilitating functional safety or as compliant with industry functional safety standards, such products are intended to help enable customers to design and create their own applications that meet applicable functional safety standards and requirements. Using products in an application does not by itself establish any safety features in the application. Designers must ensure compliance with safety-related requirements and standards applicable to their applications. Designer may not use any TI products in life-critical medical equipment unless authorized officers of the parties have executed a special contract specifically governing such use. Life-critical medical equipment is medical equipment where failure of such equipment would cause serious bodily injury or death (e.g., life support, pacemakers, defibrillators, heart pumps, neurostimulators, and implantables). Such equipment includes, without limitation, all medical devices identified by the U.S. Food and Drug Administration as Class III devices and equivalent classifications outside the U.S.

TI may expressly designate certain products as completing a particular qualification (e.g., Q100, Military Grade, or Enhanced Product). Designers agree that it has the necessary expertise to select the product with the appropriate qualification designation for their applications and that proper product selection is at Designers' own risk. Designers are solely responsible for compliance with all legal and regulatory requirements in connection with such selection.

Designer will fully indemnify TI and its representatives against any damages, costs, losses, and/or liabilities arising out of Designer's non-compliance with the terms and provisions of this Notice.