

MEMS audio sensor omnidirectional digital microphone

Datasheet - production data

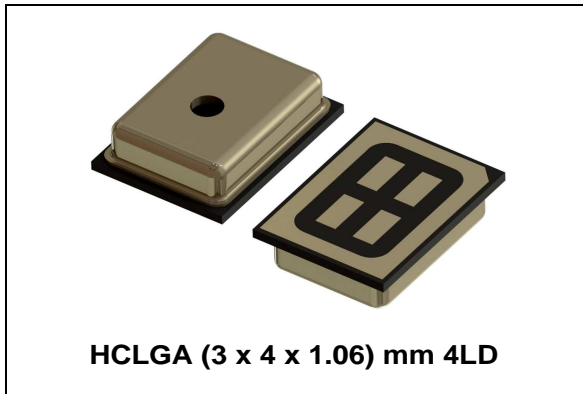

- Speech recognition
- A/V eLearning devices
- Gaming and virtual reality input devices
- Digital still and video cameras
- Antitheft systems

Description

The MP34DT02 is an ultra-compact, low-power, omnidirectional, digital MEMS microphone built with a capacitive sensing element and an IC interface.

The sensing element, capable of detecting acoustic waves, is manufactured using a specialized silicon micromachining process dedicated to produce audio sensors.

The IC interface is manufactured using a CMOS process that allows designing a dedicated circuit able to provide a digital signal externally in PDM format.

The MP34DT02 has an acoustic overload point of 120 dB SPL with a 60 dB signal-to-noise ratio and -26 dBFS sensitivity.

The MP34DT02 is available in a top-port, SMD-compliant, EMI-shielded package and is guaranteed to operate over an extended temperature range from -40 °C to +85 °C.

Features

- Single supply voltage
- Low power consumption
- 120 dB SPL acoustic overload point
- 60 dB signal-to-noise ratio
- Omnidirectional sensitivity
- -26 dBFS sensitivity
- PDM output
- HCLGA package
 - Top-port design
 - SMD-compliant
 - EMI-shielded
 - ECOPACK®, RoHS, and “Green” compliant

Applications

- Mobile terminals
- Laptop and notebook computers
- Portable media players
- VoIP

Table 1. Device summary

Order codes	Temperature range [°C]	Package	Packing
MP34DT02	-40 to +85	HCLGA (3 x 4 x 1.06) mm 4LD	Tray
MP34DT02TR	-40 to +85	HCLGA (3 x 4 x 1.06) mm 4LD	Tape and reel

Contents

- 1 Pin description 3**
- 2 Acoustic and electrical specifications 4**
 - 2.1 Acoustic and electrical characteristics 4
 - 2.2 Frequency response 5
- 3 Application recommendations 6**
 - 3.1 Timing characteristics 7
- 4 Sensing element 8**
- 5 Absolute maximum ratings 9**
- 6 Functionality 10**
 - 6.1 L/R channel selection 10
- 7 Package mechanical data 11**
- 8 Carrier tape mechanical specifications 13**
- 9 Process recommendations 14**
- 10 Revision history 15**

1 Pin description

Figure 1. Pin connections

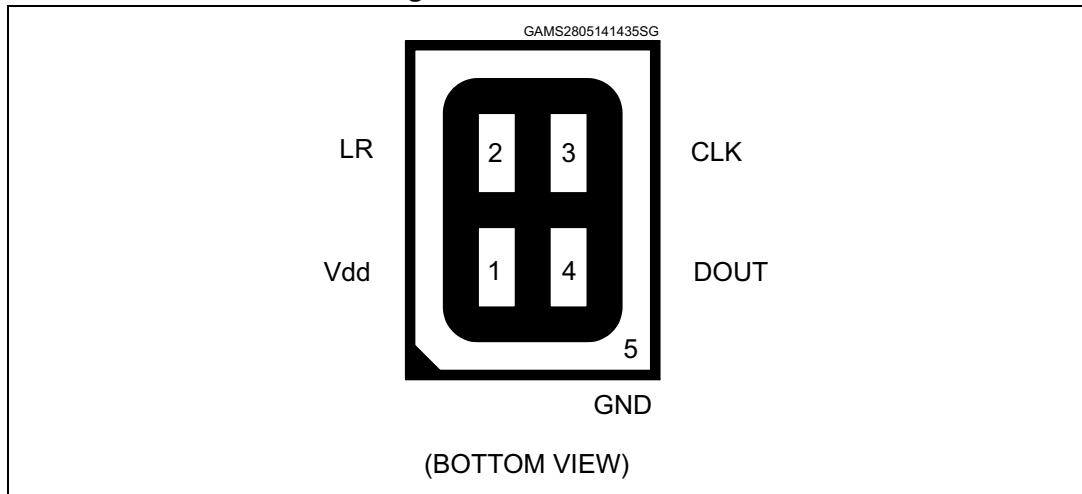

Table 2. Pin description

Pin n°	Pin name	Function
1	Vdd	Power supply
2	LR	Left/Right channel selection
3	CLK	Synchronization input clock
4	DOUT	Left/Right PDM data output
5 (ground ring)	GND	0 V supply

2 Acoustic and electrical specifications

2.1 Acoustic and electrical characteristics

The values listed in the table below are specified for Vdd = 1.8 V, Clock = 2.4 MHz, T = 25 °C, unless otherwise noted.

Table 3. Acoustic and electrical characteristics

Symbol	Parameter	Test condition	Min.	Typ. ⁽¹⁾	Max.	Unit
Vdd	Supply voltage		1.64	1.8	3.6	V
Idd	Current consumption in normal mode	Mean value		0.6		mA
IddPdn	Current consumption in power-down mode ⁽²⁾			20		μA
Sc	Short-circuit current		1		10	mA
AOP	Acoustic overload point			120		dB SPL
So	Sensitivity		-29	-26	-23	dBFS
SNR	Signal-to-noise ratio	A-weighted at 1 kHz, 1 Pa		60		dB
PSR	Power supply rejection	Guaranteed by design		-70		dBFS
Clock	Input clock frequency ⁽³⁾		1	2.4	3.25	MHz
Ton	Turn-on time ⁽⁴⁾	Guaranteed by design			10	ms
Top	Operating temperature range		-40		+85	°C
V _{IOL}	Low level logic input/output voltage	I _{out} = 1 mA	-0.3		0.35xVdd	V
V _{IOH}	High level logic input/output voltage	I _{out} = 1 mA	0.65xVdd		Vdd+0.3	V

1. Typical specifications are not guaranteed.
2. Input clock in static mode.
3. Duty cycle: min = 40% max = 60%.
4. Time from the first clock edge to valid output data.

Table 4. Distortion specifications

Parameter	Test condition	Value
Distortion	100 dB SPL (1 kHz)	< 1% THD+N
Distortion	115 dB SPL (1 kHz)	< 2% THD+N
Distortion	120 dB SPL (1 kHz)	< 10% THD+N

2.2 Frequency response

Figure 2. Typical frequency response normalized at 1 kHz

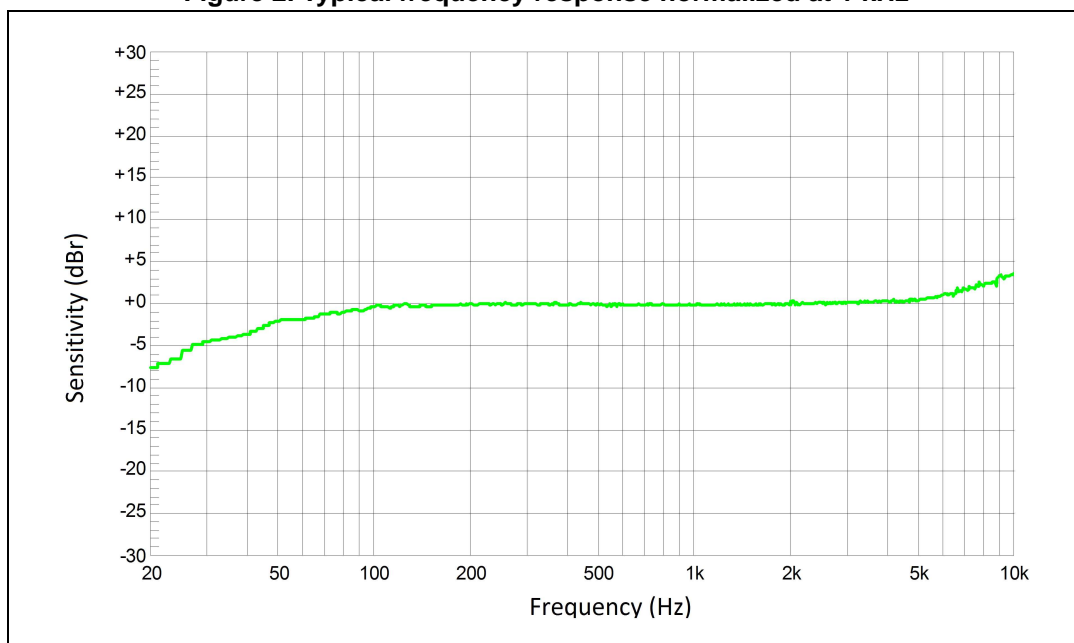

3 Application recommendations

Figure 3. MP34DT02 electrical connections (Top view)

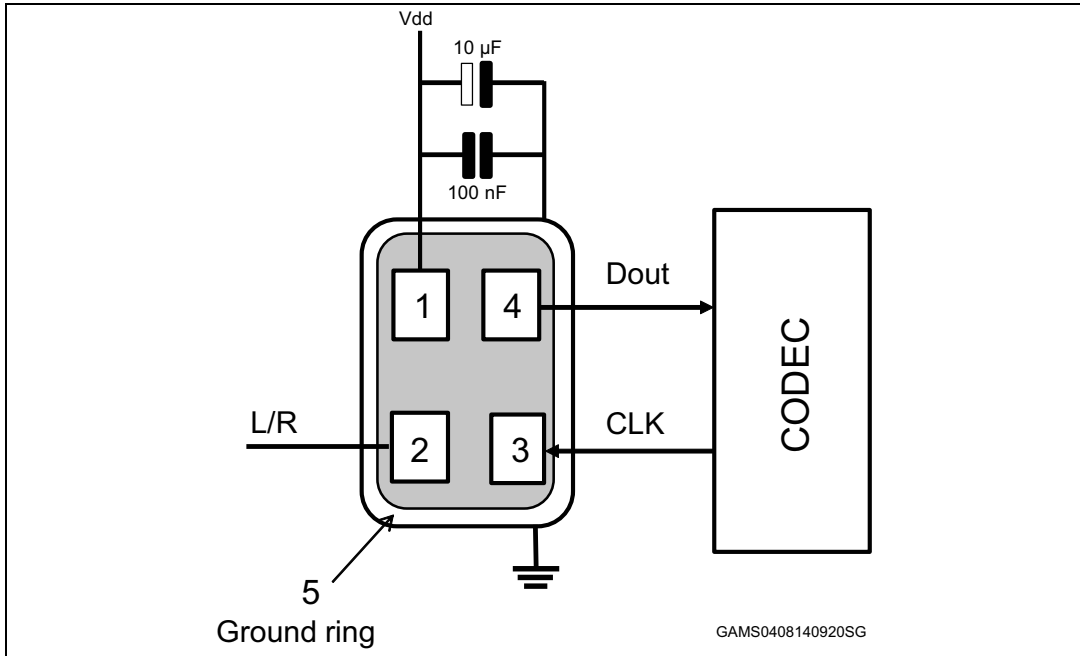
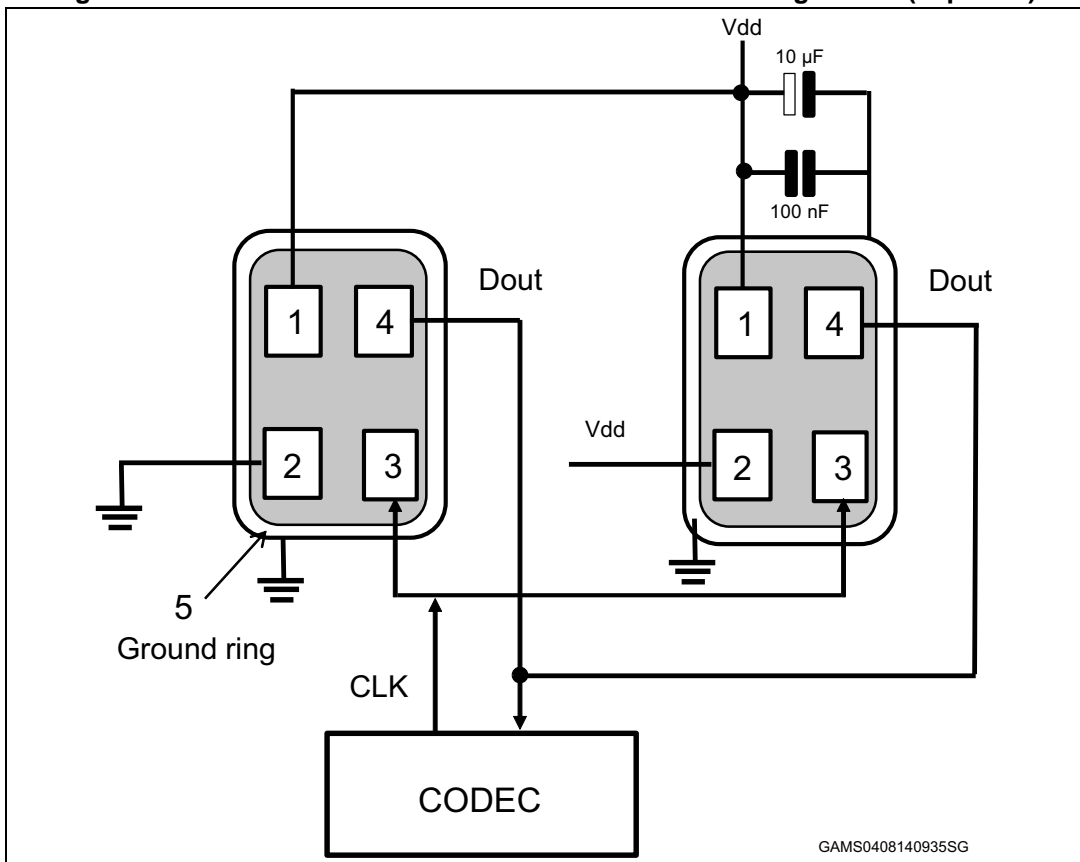

Figure 4. MP34DT02 electrical connections for stereo configuration (Top view)



Power supply decoupling capacitors (100 nF ceramic, 10 μ F ceramic) should be placed as near as possible to pin 1 of the device (common design practice).

The L/R pin must be connected to Vdd or GND (refer to [Table 5](#)).

3.1 Timing characteristics

Table 5. Timing characteristics

Parameter	Description	Min	Max	Unit
f_{CLK}	Clock frequency for normal mode	1	3.25	MHz
f_{PD}	Clock frequency for power-down mode		0.23	MHz
T_{CLK}	Clock period for normal mode	308	1000	ns
$T_{R,EN}$	Data enabled on DATA line, L/R pin = 1	18 ⁽¹⁾		ns
$T_{R,DIS}$	Data disabled on DATA line, L/R pin = 1		16 ⁽¹⁾	ns
$T_{L,EN}$	Data enabled on DATA line, L/R pin = 0	18 ⁽¹⁾		ns
$T_{L,DIS}$	Data disabled on DATA line, L/R pin = 0		16 ⁽¹⁾	ns

1. From design simulations

Figure 5. Timing waveforms

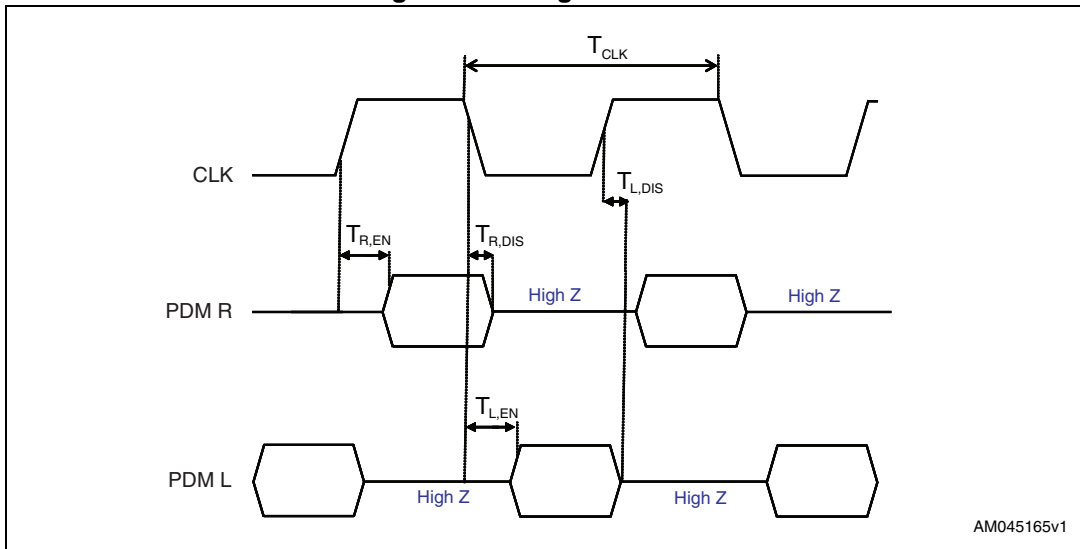

AM045165v1

4 Sensing element

The sensing element shall mean the acoustic sensor consisting of a conductive movable plate and a fixed plate placed in a tiny silicon chip. This sensor transducers the sound pressure into the changes of coupled capacity between those two plates.

Omron Corporation supplies this element for STMicroelectronics.

5 Absolute maximum ratings

Stresses above those listed as “absolute maximum ratings” may cause permanent damage to the device. This is a stress rating only and functional operation of the device under these conditions is not implied. Exposure to maximum rating conditions for extended periods may affect device reliability.

Table 6. Absolute maximum ratings

Symbol	Ratings	Maximum value	Unit
Vdd	Supply voltage	-0.3 to 6	V
Vin	Input voltage on any control pin	-0.3 to Vdd +0.3	V
T _{STG}	Storage temperature range	-40 to +125	°C
ESD	Electrostatic discharge protection	2 (HBM)	kV
	3 discharges at ± 8 kV direct contact to lid when unit is grounded (IEC 61000-4-2) and 3 discharges at ± 2 kV direct contact to I/O pins. (MIL 883E, Method 3015.7)	± 8	kV



This device is sensitive to mechanical shock, improper handling can cause permanent damage to the part.



This device is ESD-sensitive, improper handling can cause permanent damage to the part.

6 Functionality

6.1 L/R channel selection

The L/R digital pad lets the user select the DOUT signal pattern as shown in [Table 7](#). The L/R pin must be connected to Vdd or GND.

Table 7. L/R channel selection

L/R	CLK low	CLK high
GND	Data valid	High impedance
Vdd	High impedance	Data valid

7 Package mechanical data

In order to meet environmental requirements, ST offers these devices in different grades of ECOPACK® packages, depending on their level of environmental compliance. ECOPACK® specifications, grade definitions and product status are available at: www.st.com. ECOPACK® is an ST trademark.

Soldering information

The HCLGA 3x4 4LD package is also compliant with the RoHS and “Green” standards and is qualified for soldering heat resistance according to JEDEC J-STD-020.

Landing pattern and soldering recommendations are available at www.st.com.

Figure 6. Recommended soldering profile limits

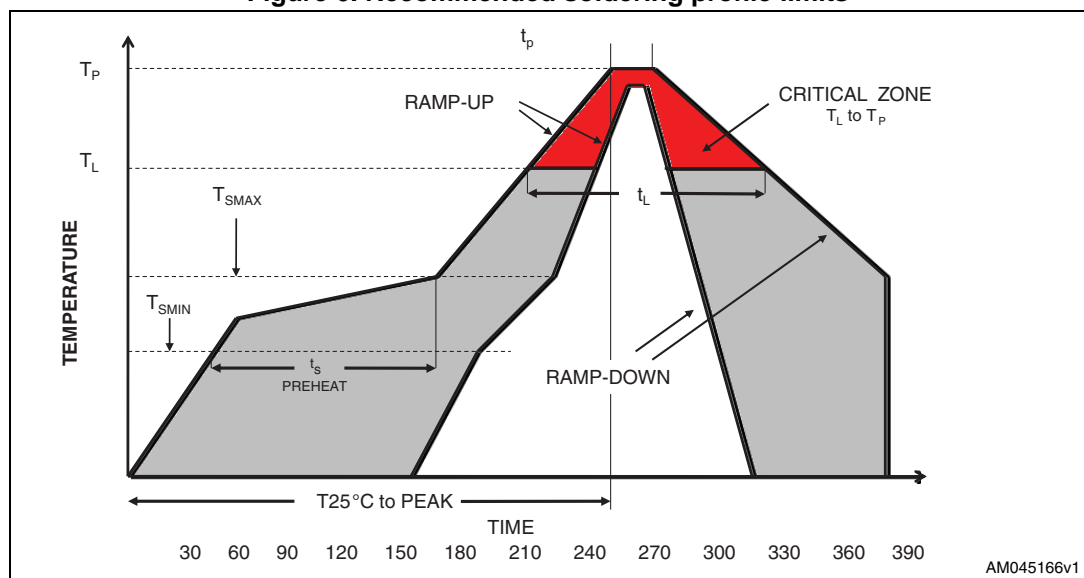
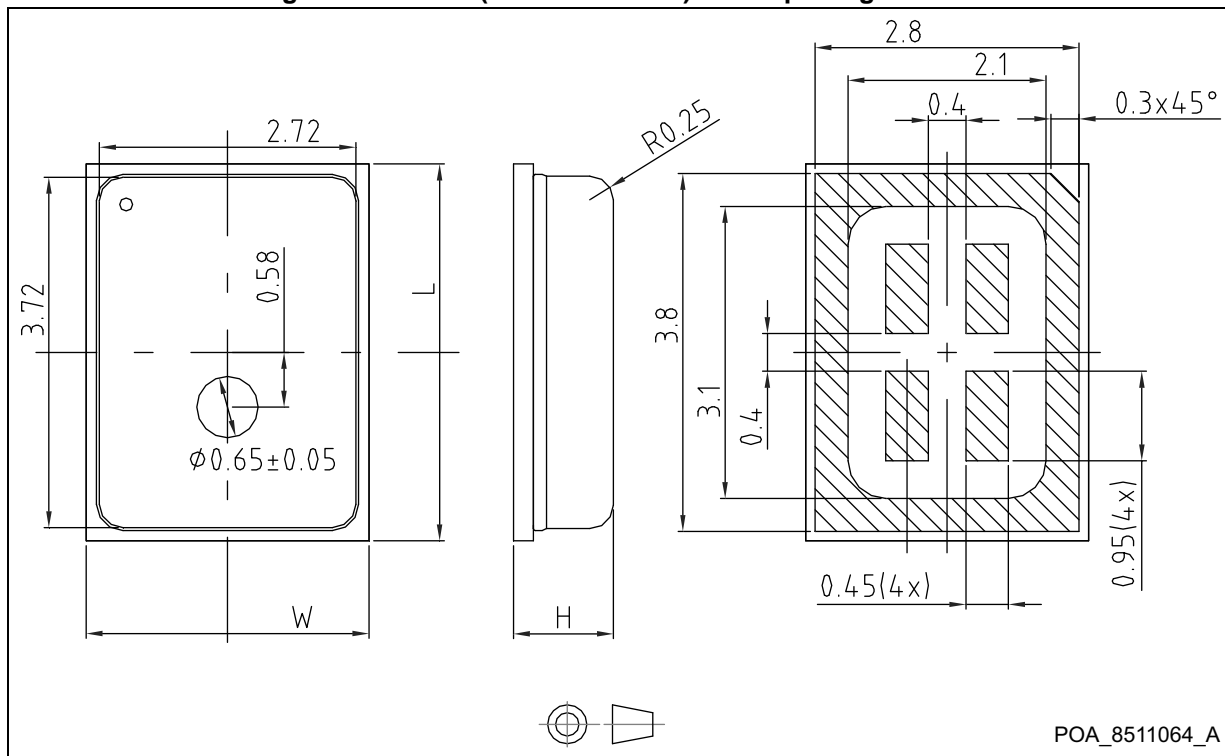

Table 8. Recommended soldering profile limits

Description	Parameter	Pb free
Average ramp rate	T_L to T_P	3 °C/sec max
Preheat		
Minimum temperature	T_{SMIN}	150 °C
Maximum temperature	T_{SMAX}	200 °C
Time (T_{SMIN} to T_{SMAX})	t_s	60 sec to 120 sec
Ramp-up rate	T_{SMAX} to T_L	
Time maintained above liquidus temperature	t_L	60 sec to 150 sec
Liquidus temperature	T_L	217 °C
Peak temperature	T_P	260 °C max
Time within 5 °C of actual peak temperature		20 sec to 40 sec
Ramp-down rate		6 °C/sec max
Time 25 °C ($t_{25\text{ °C}}$) to peak temperature		8 minutes max

Figure 7. HCLGA (3 x 4 x 1.06 mm) 4-lead package outline



Note: The MEMS microphone metal cap can exhibit some level of variation in color when the device is subjected to thermal process.
 Dimensions are in millimeter unless otherwise specified. General tolerance is ± 0.15 mm unless otherwise specified.

Table 9. HCLGA (3 x 4 x 1.06 mm) mechanical data

Item	Dimension (mm)	Tolerance (mm)
Length [L]	4	± 0.1
Width [W]	3	± 0.1
Height [H]	1.06	± 0.1

8 Carrier tape mechanical specifications

Figure 8. Carrier tape without microphone-top view

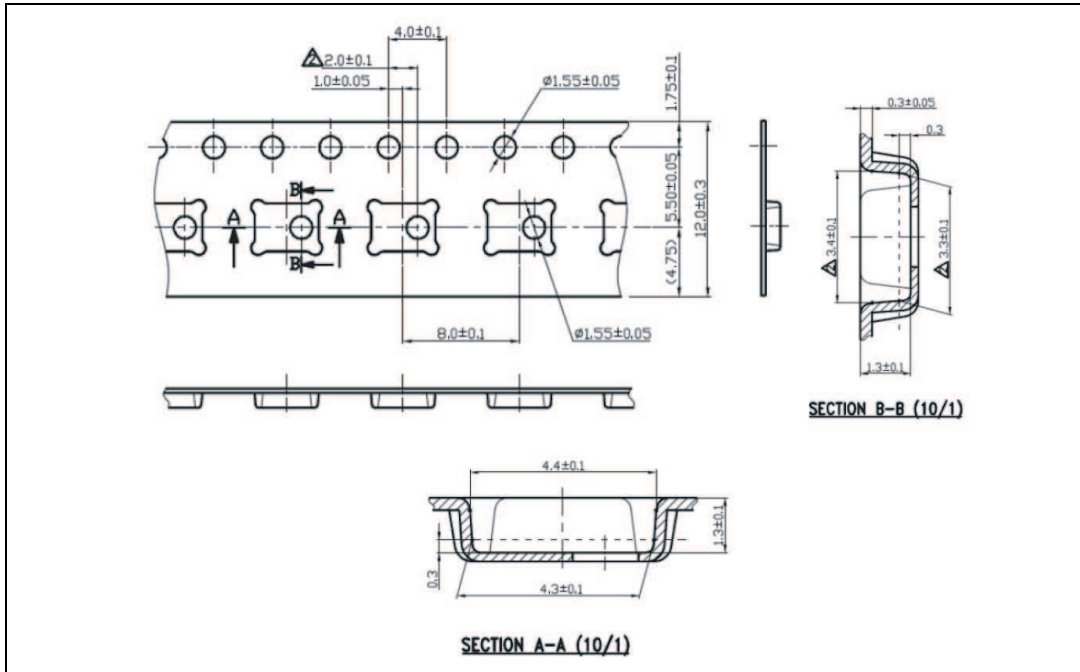
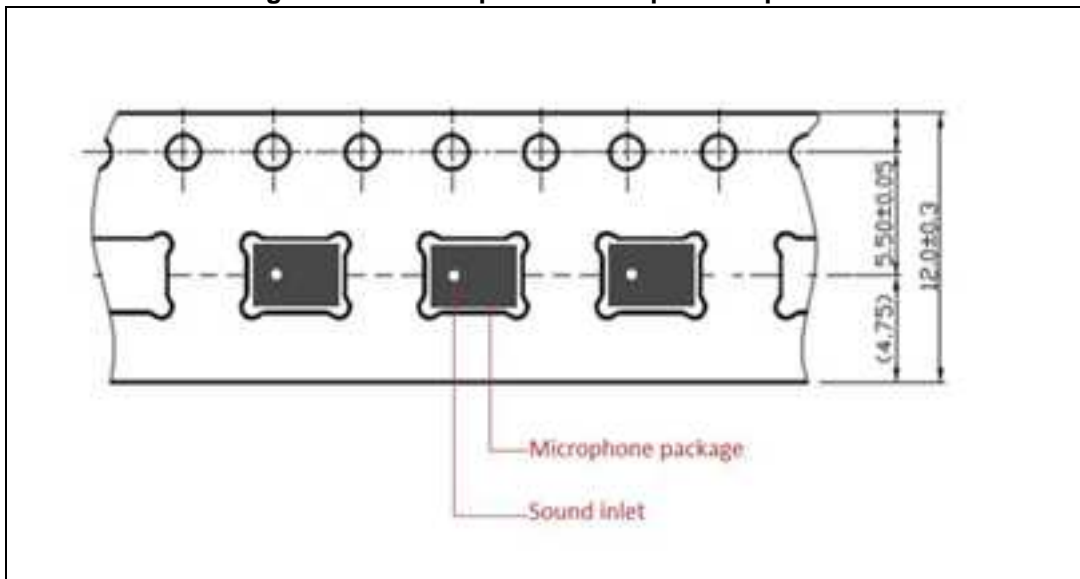

Figure 9. Carrier tape with microphone-top view



9 Process recommendations

To ensure a consistent manufacturing process it is strongly advised to comply with following recommendations:

- The recommended pick-up area for the MP34DT02 package must be defined using the worst case (ie. no device alignment during picking process). This area has been defined considering all the tolerances of the components involved (reel, package, sound inlet). Picker tolerance shall be considered as well.
- To prevent damage to the MEMS membrane or incorrect pick-up and placement, do not pick up the component on the inlet area
- For the package outline please refer to [Figure 10](#). Nozzle shape, size, and placement accuracy are the other key factors to consider when deciding on the coordinates for the picking.
- Device alignment before picking is highly recommended.
- A vacuum force greater than 7 psi must be avoided
- 1 kPa = 0.145 psi (lb/in²) = 0.0102 kgf/cm² = 0.0098 atm
- All the recommended dimensions (device safe pick area) do not include the pick and place equipment tolerances
- According to [Figure 10](#), standard picker tool can be used to handle this device

Figure 10. Recommended picking area

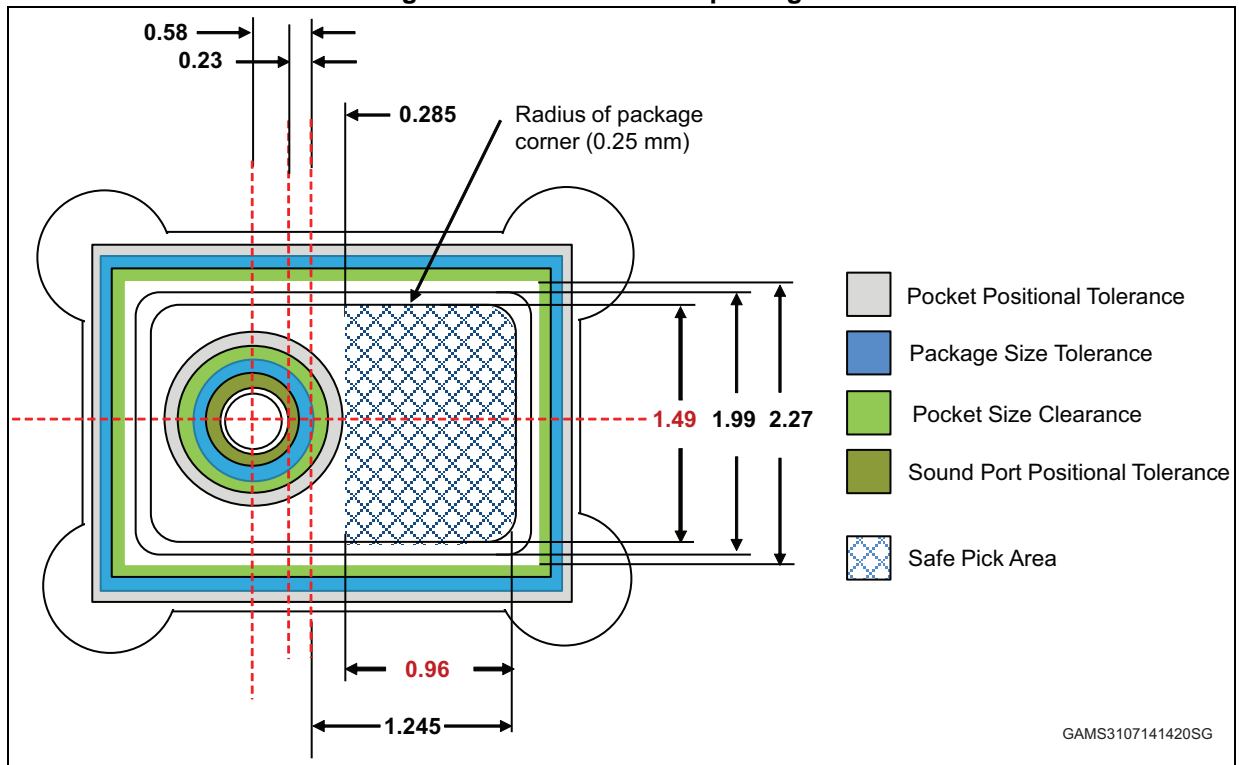

10 Revision history

Table 10. Document revision history

Date	Revision	Changes
19-Jun-2014	1	Initial release
03-Sep-2014	2	Updated sensitivity values parameter Table 3 on page 4 Added: <ul style="list-style-type: none">– Table 4: Distortion specifications on page 4 and Figure 2: Typical frequency response normalized at 1 kHz on page 5– Section 3: Application recommendations on page 6– Section 9: Process recommendations on page 14

IMPORTANT NOTICE – PLEASE READ CAREFULLY

STMicroelectronics NV and its subsidiaries ("ST") reserve the right to make changes, corrections, enhancements, modifications, and improvements to ST products and/or to this document at any time without notice. Purchasers should obtain the latest relevant information on ST products before placing orders. ST products are sold pursuant to ST's terms and conditions of sale in place at the time of order acknowledgement.

Purchasers are solely responsible for the choice, selection, and use of ST products and ST assumes no liability for application assistance or the design of Purchasers' products.

No license, express or implied, to any intellectual property right is granted by ST herein.

Resale of ST products with provisions different from the information set forth herein shall void any warranty granted by ST for such product.

ST and the ST logo are trademarks of ST. All other product or service names are the property of their respective owners.

Information in this document supersedes and replaces information previously supplied in any prior versions of this document.

© 2014 STMicroelectronics – All rights reserved