

Silicon PNP Power Transistors

MJE15029

DESCRIPTION

- With TO-220C package
- Complement to type MJE15028
- High transition frequency
- DC Current Gain Specified to 4.0 Amperes
 - $h_{FE} = 40$ (Min) @ $I_C = -3.0$ Adc
 - $h_{FE} = 20$ (Min) @ $I_C = -4.0$ Adc

APPLICATIONS

- Designed for use as high-frequency drivers in audio amplifiers.

PINNING

PIN	DESCRIPTION
1	Emitter
2	Collector;connected to mounting base
3	Base

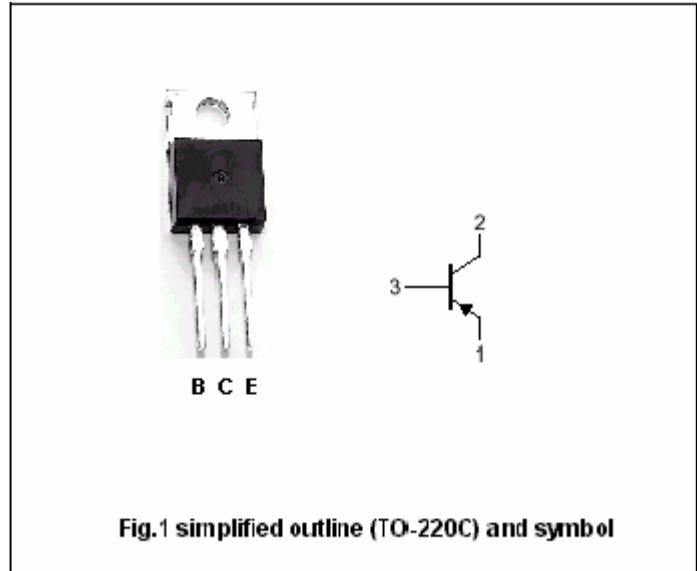

Absolute maximum ratings (Tc=25°C)

SYMBOL	PARAMETER	CONDITIONS	VALUE	UNIT
V_{CBO}	Collector-base voltage	Open emitter	-120	V
V_{CEO}	Collector-emitter voltage	Open base	-120	V
V_{EBO}	Emitter-base voltage	Open collector	-5	V
I_C	Collector current (DC)		-8	A
I_{CM}	Collector current-Peak		-16	A
I_B	Base current		-2	A
P_D	Total power dissipation	$T_a=25^\circ\text{C}$	2	W
		$T_C=25^\circ\text{C}$	50	
T_j	Junction temperature		150	°C
T_{stg}	Storage temperature		-65~150	°C

THERMAL CHARACTERISTICS

SYMBOL	PARAMETER	MAX	UNIT
$R_{th\ j-C}$	Thermal resistance ; junction to case	2.5	°C/W
$R_{th\ j-A}$	Thermal resistance , junction to ambient	62.5	°C/W

Silicon PNP Power Transistors

MJE15029

CHARACTERISTICS

T_j=25 °C unless otherwise specified

SYMBOL	PARAMETER	CONDITIONS	MIN	TYP.	MAX	UNIT
V _{CEQ(SUS)}	Collector-emitter sustaining voltage	I _C =-10mA; I _B =0	-120			V
V _{CEsat}	Collector-emitter saturation voltage	I _C =-1A ;I _B =-0.1A			-0.5	V
V _{BE}	Base-emitter on voltage	I _C =-1A ; V _{CE} =-2V			-1.0	V
I _{CBO}	Collector cut-off current	V _{CB} =-120V; I _E =0			-10	μA
I _{CEO}	Collector cut-off current	V _{CE} =-120V; I _B =0			-0.1	mA
I _{EBO}	Emitter cut-off current	V _{EB} =-5V; I _C =0			-10	μA
h _{FE-1}	DC current gain	I _C =-0.1A ; V _{CE} =-2V	40			
h _{FE-2}	DC current gain	I _C =-2A ; V _{CE} =-2V	40			
h _{FE-3}	DC current gain	I _C =-3A ; V _{CE} =-2V	40			
h _{FE-4}	DC current gain	I _C =-4A ; V _{CE} =-2V	20			
f _T	Transition frequency	I _C =0.5A;V _{CE} =-10V;f=10MHz	30			MHz

Silicon PNP Power Transistors

MJE15029

PACKAGE OUTLINE

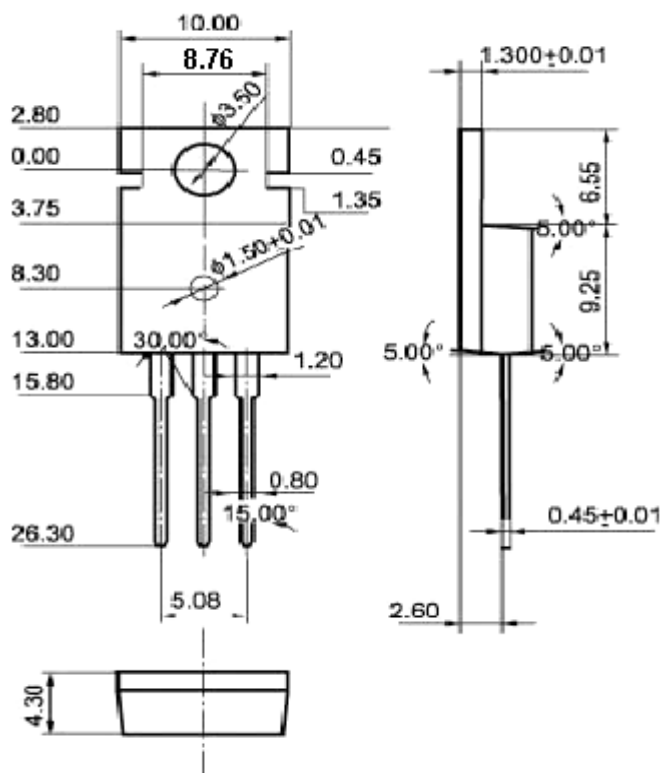

Fig.2 Outline dimensions (unindicated tolerance: ±0.10mm)

Silicon PNP Power Transistors

MJE15029

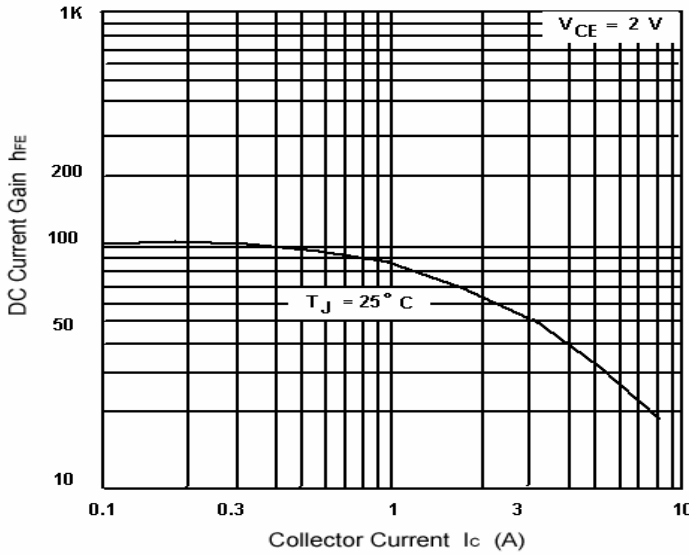

Fig.3 DC current Gain

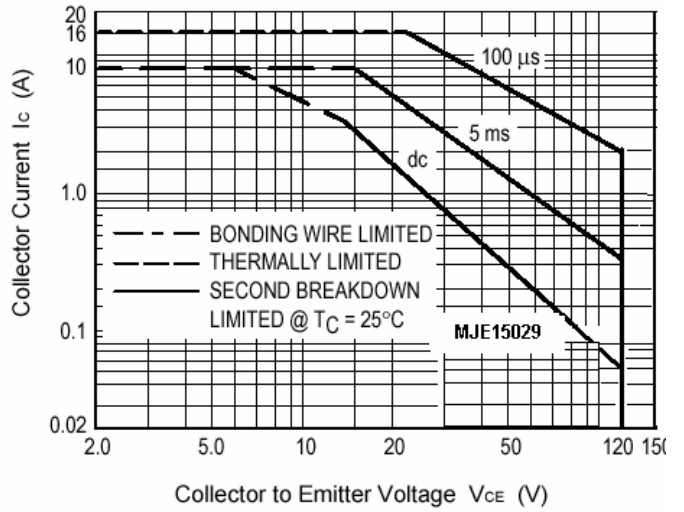

Fig.4 Safe Operating Area

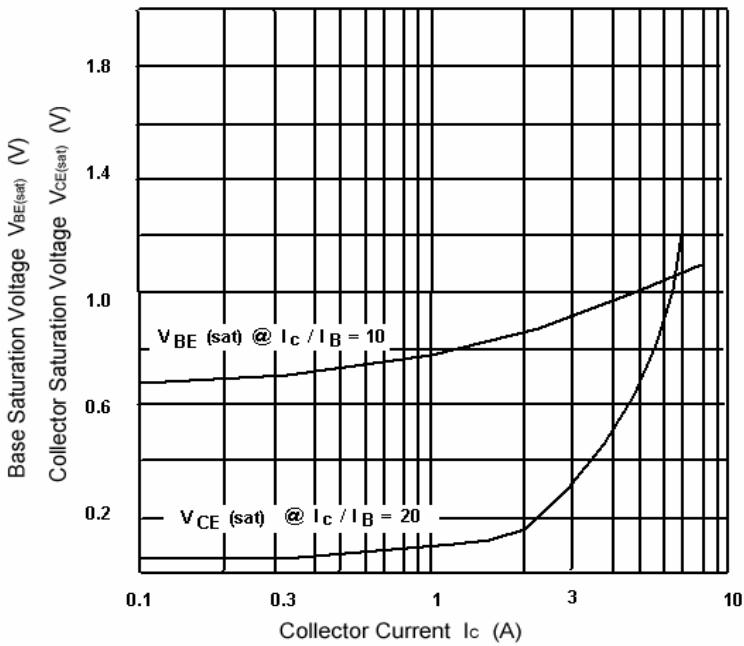

Fig.5 Base-Emitter Saturation Voltage
Collector-Emitter Saturation Voltage