

General Description

The MIC5331 is a tiny dual low quiescent current LDO ideal for applications that are power sensitive. The MIC5331 integrates two high performance, 300mA LDOs into a tiny 2mm x 2mm Thin MLF® package, which occupies less PC board area than a single SOT-23 package.

The MIC5331 is designed to reject input noise and provide low output noise with fast transient response to any load change quickly even though it is a low quiescent current part. This combination of PSRR, low noise and transient response along with low power consumption makes for a very high performance, yet general purpose product.

The MIC5331 is a μ Cap design, operating with very small ceramic output capacitors, which reduces required board space and component cost; and it is available in fixed output voltages in the tiny 8-pin 2mm x 2mm Thin MLF® leadless package.

Data sheets and support documentation can be found on Micrel's web site at: www.micrel.com.

Features

- 2.3V to 5.5V input voltage range
- 300mA output current per LDO
- Very low quiescent current: 25 μ A per LDO
- High PSRR - >65dB on each LDO
- Stable with 1 μ F ceramic output capacitors
- Tiny 8-pin 2mm x 2mm Thin MLF® package
- Ultra-low dropout voltage – 120mV @ 300mA
- Low output voltage noise – 50 μ Vrms
- Thermal shutdown protection
- Current limit protection

Applications

- Camera phones
- Mobile phones
- PDAs
- GPS receivers
- Portable devices

Typical Application

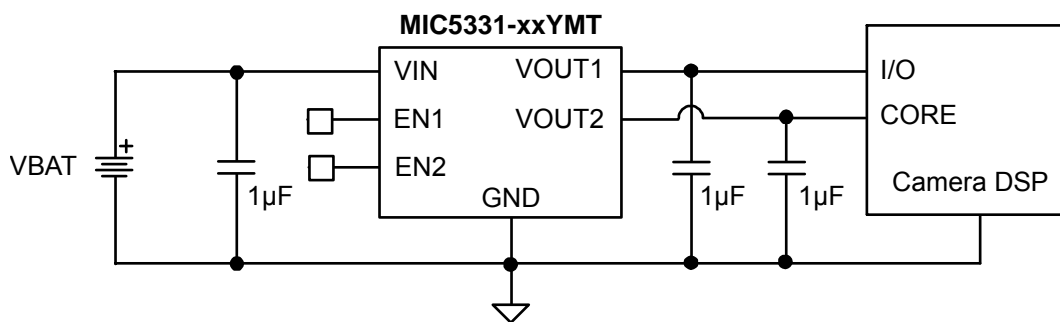

Camera DSP Power Supply Circuit

ULDO is a trademark of Micrel, Inc.

MLF and *MicroLeadFrame* are registered trademarks of Amkor Technology, Inc.

Micrel Inc. • 2180 Fortune Drive • San Jose, CA 95131 • USA • tel +1 (408) 944-0800 • fax + 1 (408) 474-1000 • <http://www.micrel.com>

Ordering Information

Part Number	Manufacturing Part Number	Marking	Voltage	Junction Temperature Range	Package
MIC5331-1.8/1.2YMT	MIC5331-G4YMT	UG4	1.8V/1.2V	-40° to +125°C	8-Pin 2mm x 2mm Thin MLF [®]
MIC5331-2.5/1.2YMT	MIC5331-J4YMT	UJ4	2.5V/1.2V	-40° to +125°C	8-Pin 2mm x 2mm Thin MLF [®]
MIC5331-2.8/2.8YMT	MIC5331-MMYMT	UMM	2.8V/2.8V	-40° to +125°C	8-Pin 2mm x 2mm Thin MLF [®]
MIC5331-2.8/2.85YMT	MIC5331-MNYMT	UMN	2.8V/2.85V	-40° to +125°C	8-Pin 2mm x 2mm Thin MLF [®]
MIC5331-2.85/2.85YMT	MIC5331-NNYMT	UNN	2.85V/2.85V	-40° to +125°C	8-Pin 2mm x 2mm Thin MLF [®]
MIC5331-3.0/2.8YMT	MIC5331-PMYMT	UPM	3.0V/2.8V	-40° to +125°C	8-Pin 2mm x 2mm Thin MLF [®]
MIC5331-3.0/2.85YMT	MIC5331-PNYMT	UPN	3.0V/2.85V	-40° to +125°C	8-Pin 2mm x 2mm Thin MLF [®]
MIC5331-3.0/3.0YMT	MIC5331-PPYMT	UPP	3.0V/3.0V	-40° to +125°C	8-Pin 2mm x 2mm Thin MLF [®]

Note: Other voltage options available. Contact Micrel for details.

Pin Configuration

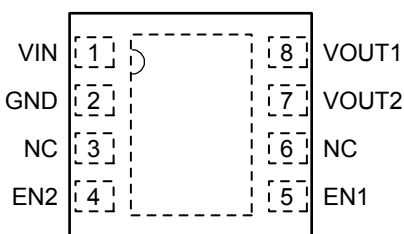

8-Pin 2mm x 2mm Thin MLF[®] (MT)
(Top View)

Pin Description

Pin Number	Pin Name	Pin Function
1	VIN	Supply Input.
2	GND	Ground.
3	NC	Not Internally Connected.
4	EN2	Enable Input (Regulator 2): Active High Input. Logic High = On; Logic Low = Off. Do not leave floating.
5	EN1	Enable Input (Regulator 1): Active High Input. Logic High = On; Logic Low = Off. Do not leave floating.
6	NC	Not Internally Connected.
7	VOUT2	Regulator Output – LDO2.
8	VOUT1	Regulator Output – LDO1.

Absolute Maximum Ratings⁽¹⁾

Supply Voltage (V_{IN})	0V to +6V
Enable Input Voltage (V_{EN1} , V_{EN2})	0V to V_{IN}
Power Dissipation	Internally Limited ⁽³⁾
Lead Temperature (soldering, 3sec.)	260°C
Storage Temperature (T_s)	-65°C to +150°C
ESD Sensitive ⁽⁴⁾	

Operating Ratings⁽²⁾

Supply Voltage (V_{IN})	+2.3V to +5.5V
Enable Input Voltage (V_{EN1} , V_{EN2})	0V to V_{IN}
Junction Temperature (T_J)	-40°C to +125°C
Junction Thermal Resistance	
2mm x 2mm Thin MLF-8 (θ_{JA})	90°C/W

Electrical Characteristics⁽⁵⁾

$V_{IN} = V_{EN1} = V_{EN2} = V_{OUT} + 1.0V$, higher of the two regulator outputs; $I_{OUT1} = I_{OUT2} = 100\mu A$; $C_{OUT1} = C_{OUT2} = 1\mu F$;
 $T_J = 25^\circ C$, **bold** values indicate $-40^\circ C \leq T_J \leq +125^\circ C$; unless noted.

Parameter	Condition	Min	Typ	Max	Units
Output Voltage Accuracy	Variation from nominal V_{OUT}	-1.0		+1.0	%
	Variation from nominal V_{OUT} ; -40°C to +125°C	-2.0		+2.0	%
Line Regulation	$V_{IN} = V_{OUT} + 1V$ to 5.5V; $I_{OUT} = 100\mu A$		0.02	0.3	%/V
				0.6	%/V
Load Regulation	$I_{OUT} = 100\mu A$ to 300mA		0.2	0.5	%
Dropout Voltage	$I_{OUT} = 50mA$		20	40	mV
	$I_{OUT} = 300mA$		120	240	mV
Ground Current	$V_{EN1} = \text{High}$; $V_{EN2} = \text{Low}$; $I_{OUT} = 100\mu A$ to 300mA		25	50	μA
	$V_{EN1} = \text{Low}$; $V_{EN2} = \text{High}$; $I_{OUT} = 100\mu A$ to 300mA		25	50	μA
	$V_{EN1} = V_{EN2} = \text{High}$; $I_{OUT1} = 300mA$, $I_{OUT2} = 300mA$		40	75	μA
Ground Current in Shutdown	$V_{EN1} = V_{EN2} \leq 0.2V$		0.01	1.0	μA
Ripple Rejection	$f = 1kHz$; $C_{OUT} = 2.2\mu F$		65		dB
	$f = 20kHz$; $C_{OUT} = 2.2\mu F$		45		dB
Current Limit	$V_{OUT} = 0V$	350	550	800	mA
Output Voltage Noise	$C_{OUT} = 1\mu F$; 10Hz to 100kHz		50		μV_{RMS}
Enable Inputs (EN1/EN2)					
Enable Input Voltage	Logic Low			0.2	V
	Logic High	1.2			V
Enable Input Current	$V_{IL} \leq 0.2V$		0.01	1.0	μA
	$V_{IH} \geq 1.2V$		0.01	1.0	μA
Turn-on Time					
Turn-on Time (LDO1 and 2)	$C_{OUT} = 1\mu F$ (Enable of First LDO)		140	500	μs
	$C_{OUT} = 1\mu F$ (Enable of Second LDO after First Enabled)		110	500	μs

Notes:

- Exceeding the absolute maximum rating may damage the device.
- The device is not guaranteed to function outside its operating rating.
- The maximum allowable power dissipation of any T_A (ambient temperature) is $P_{D(max)} = (T_{J(max)} - T_A) / \theta_{JA}$. Exceeding the maximum allowable power dissipation will result in excessive die temperature, and the regulator will go into thermal shutdown.
- Devices are ESD sensitive. Handling precautions recommended. Human body model, 1.5k Ω in series with 100pF.
- Specification for packaged product only.

Typical Characteristics

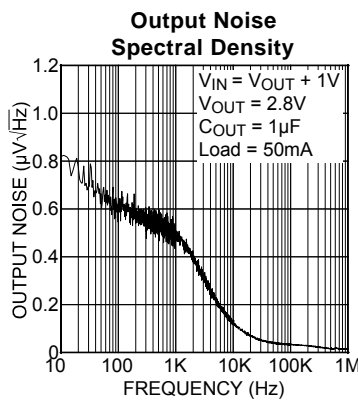
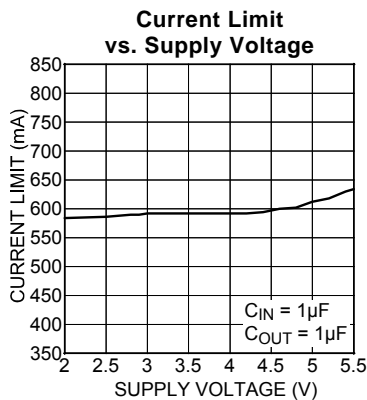
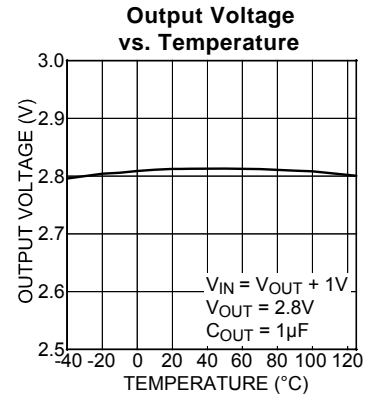
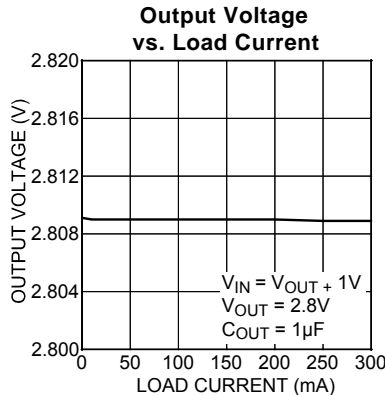
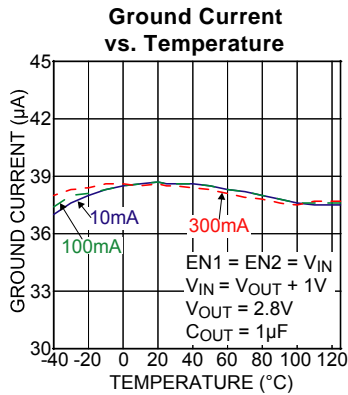
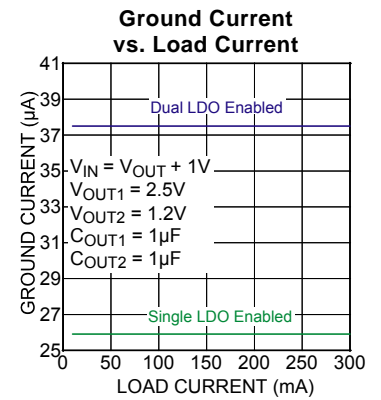
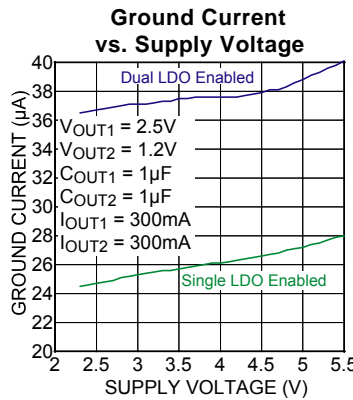
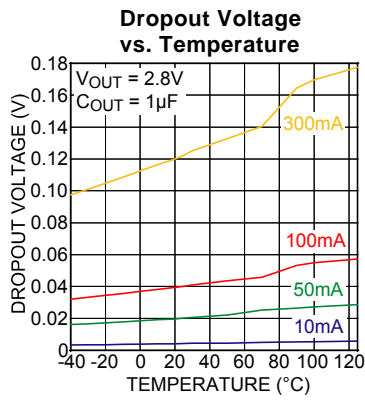
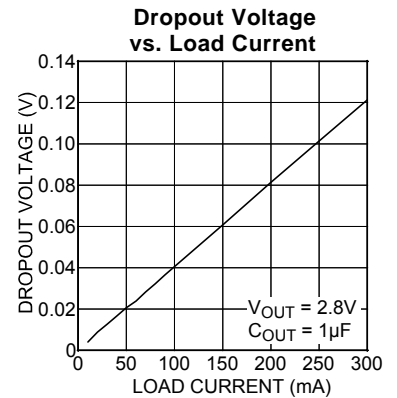
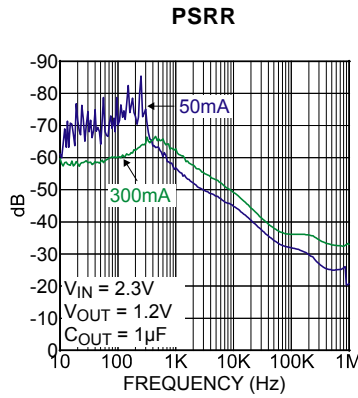
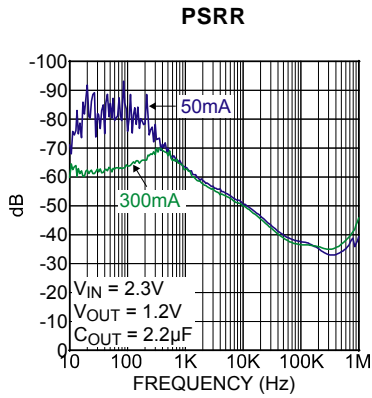

Functional Characteristics

Load Transient (0mA-150mA)

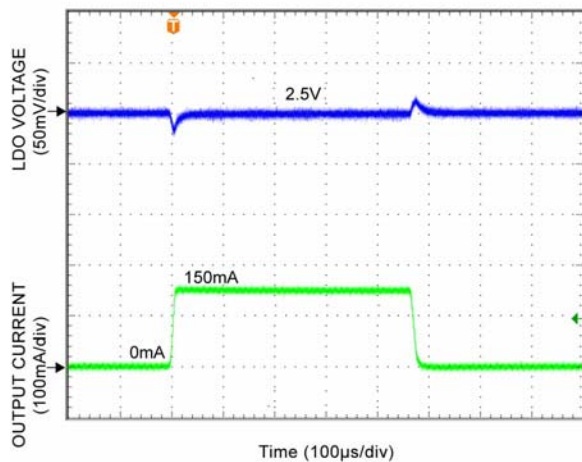

Load Transient (150mA-300mA)

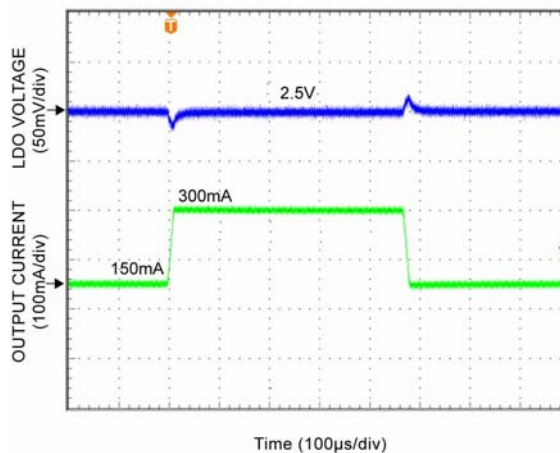

Enable Turn-On

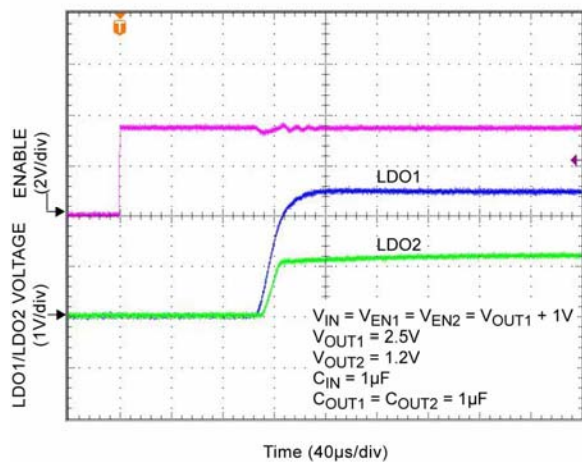

Functional Diagram

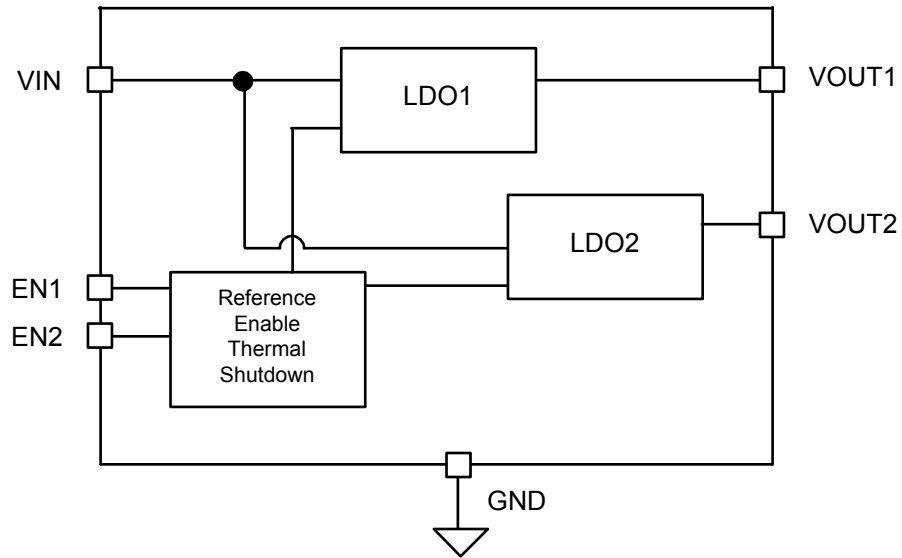

MIC5331 Block Diagram

Application Information

MIC5331 is a tiny dual low quiescent current 300mA LDO. The MIC5331 regulator is fully protected from damage due to fault conditions, offering linear current limiting and thermal shutdown.

Input Capacitor

The MIC5331 is a high-performance, high bandwidth device. Therefore, it requires a well-bypassed input supply for optimal performance. A 1 μ F capacitor is required from the input to ground to provide stability. Low-ESR ceramic capacitors provide optimal performance at a minimum of space. Additional high-frequency capacitors, such as small-valued NPO dielectric-type capacitors, help filter out high-frequency noise and are good practice in any RF-based circuit. X5R or X7R dielectrics are recommended for the input capacitor. Y5V dielectrics lose most of their capacitance over temperature and are therefore, not recommended.

Output Capacitor

The MIC5331 requires an output capacitor of 1 μ F or greater to maintain stability. The design is optimized for use with low-ESR ceramic chip capacitors. High ESR capacitors may cause high frequency oscillation. The output capacitor can be increased, but performance has been optimized for a 1 μ F ceramic output capacitor and does not improve significantly with larger capacitance.

X7R/X5R dielectric-type ceramic capacitors are recommended because of their temperature performance. X7R-type capacitors change capacitance by 15% over their operating temperature range and are the most stable type of ceramic capacitors. Z5U and Y5V dielectric capacitors change value by as much as 50% and 60%, respectively, over their operating temperature ranges. To use a ceramic chip capacitor with Y5V dielectric, the value must be much higher than an X7R ceramic capacitor to ensure the same minimum capacitance over the equivalent operating temperature range.

No-Load Stability

Unlike many other voltage regulators, the MIC5331 will remain stable and in regulation with no load. This is especially important in CMOS RAM keep-alive applications.

Enable/Shutdown

The MIC5331 comes with dual active-high enable pins that allow each regulator to be disabled independently. Forcing the enable pin low disables the regulator and sends it into a “zero” off-mode-current state. In this state, current consumed by the regulator goes nearly to zero. Forcing the enable pin high enables the output voltage. The active-high enable pin uses CMOS technology and

the enable pin cannot be left floating; a floating enable pin may cause an indeterminate state on the output.

Thermal Considerations

The MIC5331 is designed to provide 300mA of continuous current for both outputs in a very small package. Maximum ambient operating temperature can be calculated based on the output current and the voltage drop across the part. For example if the input voltage is 3.6V, the output voltage is 3.0V for V_{OUT1} , 2.8V for V_{OUT2} and the output current = 300mA. The actual power dissipation of the regulator circuit can be determined using the equation:

$$P_D = (V_{IN} - V_{OUT1}) I_{OUT1} + (V_{IN} - V_{OUT2}) I_{OUT2} + V_{IN} I_{GND}$$

Because this device is CMOS and the ground current is typically <100 μ A over the load range, the power dissipation contributed by the ground current is < 1% and can be ignored for this calculation.

$$P_D = (3.6V - 3.0V) \times 300mA + (3.6V - 2.8) \times 300mA$$

$$P_D = 0.42W$$

To determine the maximum ambient operating temperature of the package, use the junction-to-ambient thermal resistance of the device and the following basic equation:

$$P_{D(MAX)} = \left(\frac{T_{J(MAX)} - T_A}{\theta_{JA}} \right)$$

$T_{J(max)} = 125^\circ\text{C}$, and the maximum junction temperature of the die, θ_{JA} , thermal resistance = 90°C/W .

Substituting P_D for $P_{D(max)}$ and solving for the ambient operating temperature will give the maximum operating conditions for the regulator circuit. The junction-to-ambient thermal resistance for the minimum footprint is 90°C/W .

The maximum power dissipation must not be exceeded for proper operation.

For example, when operating the MIC5331-PMYMT at an input voltage of 3.6V and 300mA loads at each output with a minimum footprint layout, the maximum ambient operating temperature T_A can be determined as follows:

$$0.42W = (125^\circ\text{C} - T_A)/(90^\circ\text{C/W})$$

$$T_A = 87.2^\circ\text{C}$$

Therefore, a 3.0V/2.8V application with 300mA at each output current can accept an ambient operating temperature of 87°C in a 2mm x 2mm MLF[®] package. For a full discussion of heat sinking and thermal effects on voltage regulators, refer to the “Regulator Thermals” section of *Micrel's Designing with Low-Dropout Voltage Regulators* handbook. This information can be found on Micrel's website at:

http://www.micrel.com/_PDF/other/LDOBk_ds.pdf

MIC5331 Typical Application Circuit

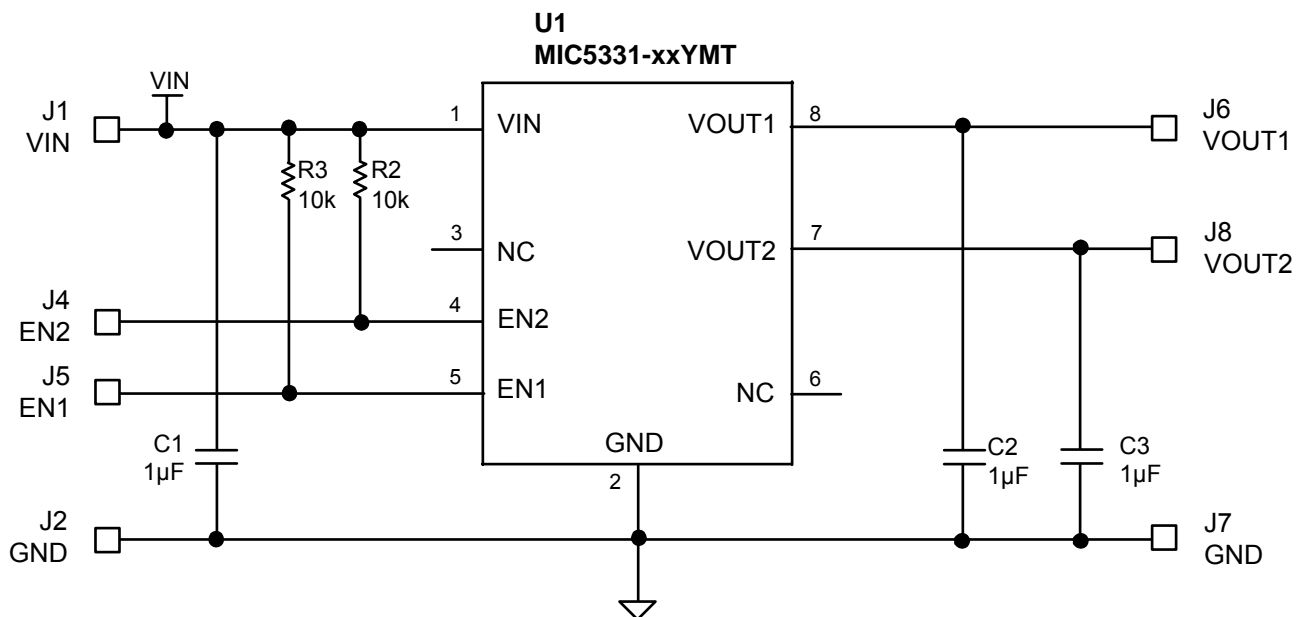

Bill of Materials

Item	Part Number	Manufacturer	Description	Qty
C1, C2, C3	C1608X5R0J105K	TDK ⁽¹⁾	Capacitor, 1µF Ceramic, 6.3V, X5R, Size 0603	3
R2, R3	CRCW06031002FKEYE3	Vishay ⁽²⁾	Resistor, 10kΩ, 1%, 1/16W, Size 0603	2
U1	MIC5331-XXYMT	Micrel ⁽³⁾	UCAP Dual 300mA LDO, Size 2mm x 2mm Thin MLF [®]	1

Notes:

1. TDK: www.tdk.com
2. Vishay: www.vishay.com
3. Micrel, Inc.: www.micrel.com

PCB Layout Recommendations

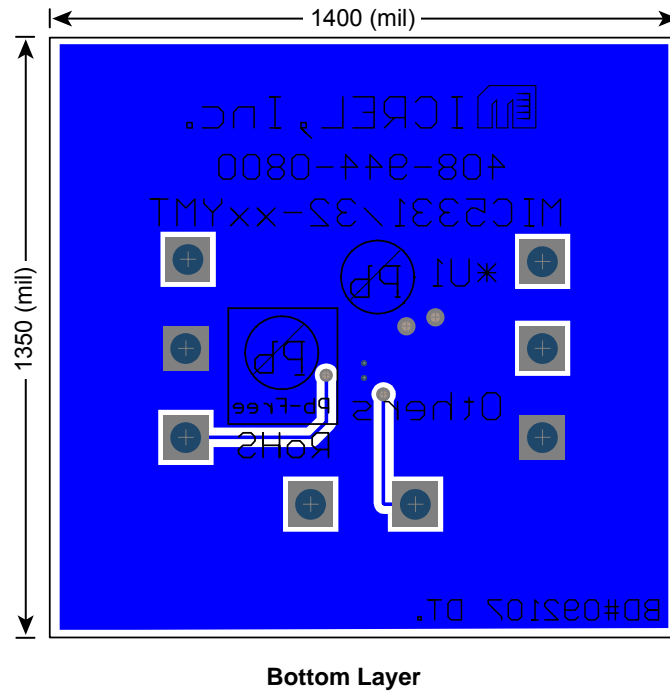
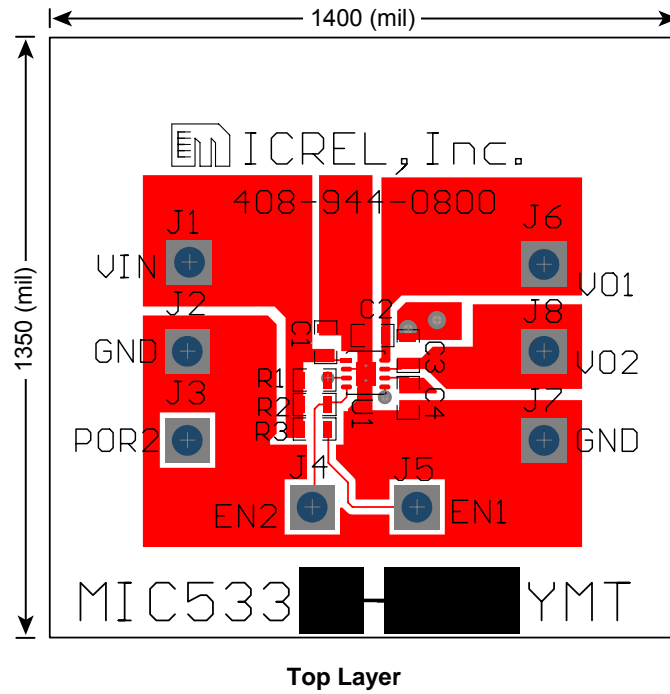

Package Information

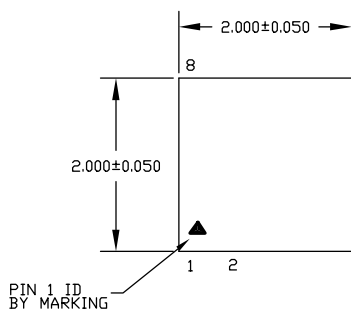

TOP VIEW

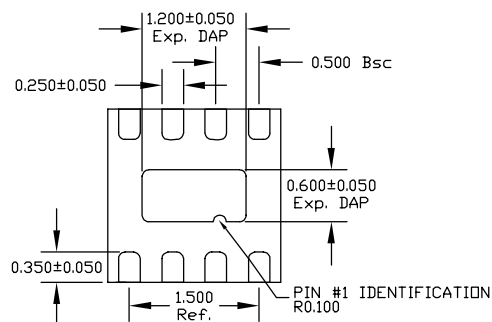

BOTTOM VIEW

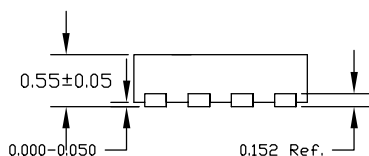

SIDE VIEW

NOTE:

1. ALL DIMENSIONS ARE IN MILLIMETERS.
2. MAX. PACKAGE WARPAGE IS 0.08 mm.
3. MAXIMUM ALLOWABLE BURRS IS 0.076 mm IN ALL DIRECTIONS.
4. PIN #1 ID WILL BE LASER MARKED.

8-Pin 2mm x 2mm Thin MLF[®] (MT)

MICREL, INC. 2180 FORTUNE DRIVE SAN JOSE, CA 95131 USA
 TEL +1 (408) 944-0800 FAX +1 (408) 474-1000 WEB <http://www.micrel.com>

The information furnished by Micrel in this data sheet is believed to be accurate and reliable. However, no responsibility is assumed by Micrel for its use. Micrel reserves the right to change circuitry and specifications at any time without notification to the customer.

Micrel Products are not designed or authorized for use as components in life support appliances, devices or systems where malfunction of a product can reasonably be expected to result in personal injury. Life support devices or systems are devices or systems that (a) are intended for surgical implant into the body or (b) support or sustain life, and whose failure to perform can be reasonably expected to result in a significant injury to the user. A Purchaser's use or sale of Micrel Products for use in life support appliances, devices or systems is a Purchaser's own risk and Purchaser agrees to fully indemnify Micrel for any damages resulting from such use or sale.

© 2008 Micrel, Incorporated.