



MIC5323

High PSRR Low Noise 300mA μ Cap
Ultra-Low Dropout LDO Regulator

General Description

The MIC5323 is a high-performance, 300mA LDO regulator, offering extremely high PSRR and very low noise while consuming low ground current.

Ideal for battery operated applications, the MIC5323 features 2% accuracy, extremely low dropout voltage (120mV @ 300mA), and low ground current at light load (typically 90 μ A). When disabled, the MIC5323 typically consumes less than 1 μ A.

The MIC5323 is a μ Cap design operating with small ceramic output capacitors for stability, thereby reducing required board space and component cost.

The MIC5323 is available in fixed output voltages and adjustable output voltages in the super compact 6-pin 2mm \times 2mm Thin MLF[®] and thin SOT-23-5 package. Additional voltage options are available. Contact Micrel marketing.

Data sheets and support documentation can be found on Micrel's web site at www.micrel.com.

Features

- Ultra low dropout voltage of 120mV @ 300mA
- Input voltage range: 2.65 to 5.5V
- Stable with ceramic output capacitor
- 300mA guaranteed output current
- Low output noise — 20 μ Vrms
- High PSRR, up to 80dB @1kHz
- Less than 30 μ s turn-on time with $C_{BYP} = 0.1\mu$ F
- High output accuracy: $\pm 2.0\%$ over temperature
- Thermal shutdown protection
- Current limit protection
- 6-pin 2mm \times 2mm Thin MLF[®] package
- Thin SOT-23-5 package

Applications

- Cellular phones
- Notebook and Tablet Computers
- Fiber optic modules
- Portable electronics
- Instrumentation Systems
- Audio Codec power supplies

Typical Application

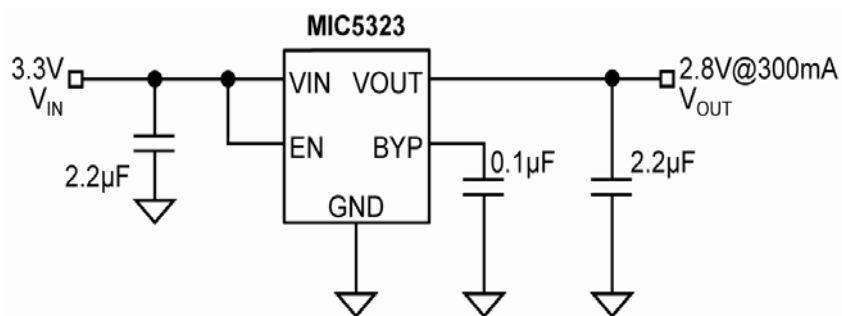

Power Supply Rejection Ratio
($C_{BYP} = 0.1\mu$ F)

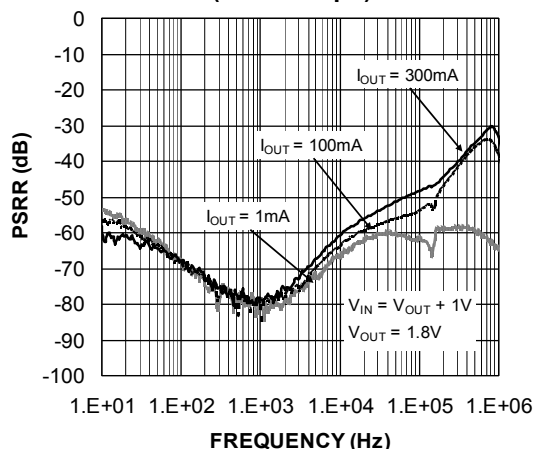

Ordering Information

Part Number ⁽¹⁾	Marking ⁽²⁾	Voltage	Junction Temp. Range ⁽²⁾	Package ⁽³⁾
MIC5323-1.8YMT	<u>23</u> G	1.8V	-40°C to +125°C	6-Pin 2mm x 2mm Thin MLF [®]
MIC5323-2.8YMT	<u>23</u> M	2.8V	-40°C to +125°C	6-Pin 2mm x 2mm Thin MLF [®]
MIC5323-3.3YMT	<u>23</u> S	3.3V	-40°C to +125°C	6-Pin 2mm x 2mm Thin MLF [®]
MIC5323YMT	<u>23</u> A	ADJ	-40°C to +125°C	6-Pin 2mm x 2mm Thin MLF [®]
MIC5323-1.8YD5	<u>23</u> 18	1.8V	-40°C to +125°C	Thin SOT23-5
MIC5323-2.8YD5	<u>23</u> 28	2.8V	-40°C to +125°C	Thin SOT23-5
MIC5323-3.3YD5	<u>23</u> 33	3.3V	-40°C to +125°C	Thin SOT23-5

Notes:

1. For other output voltage and/or temperature options, contact Micrel marketing.
2. Underbar/Overbar symbols may not be to scale.
3. Pin 1 identifier for 2x2 Thin MLF[®] is "▲" symbol.

Pin Configuration

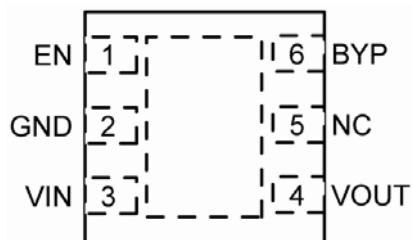

MIC5323-x.YMT (Fixed) 6-Pin 2mm x 2mm Thin MLF[®] (MT)
(Top View)

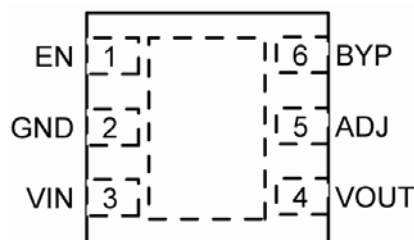

MIC5323YMT (Adjustable) 6-Pin 2mm x 2mm Thin MLF[®] (MT)
(Top View)

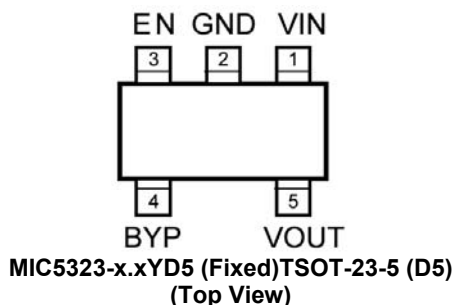

MIC5323-x.YD5 (Fixed) TSOT-23-5 (D5)
(Top View)

Pin Description

Pin Number Thin MLF [®] -6 Adjustable	Pin Number Thin MLF [®] -6 Fixed	Pin Number TSOT23-5 Fixed	Pin Name	Pin Description
1	1	3	EN	Enable Input: Active High. High = on, low = off. Do not leave floating.
2	2	2	GND	Ground.
3	3	1	VIN	Supply Input.
4	4	5	VOUT	Output Voltage.
5	–	–	ADJ	Adjust Input: Connect to external resistor voltage divider network.
–	5	–	NC	No connection for fixed voltage parts.
6	6	4	BYP	Reference Bypass: Connect external 0.1µF capacitor to GND for reduced output noise. May be left open.
EPAD	EPAD	–	EPAD	Exposed Heatsink Pad: Connect to ground plane for performance enhancement.

Absolute Maximum Ratings ⁽¹⁾

Supply Voltage (V_{IN})	0V to 6V
Enable Input Voltage (V_{EN})	0V to 6V
Power Dissipation (P_D)	Internally Limited ⁽³⁾
Junction Temperature (T_J)	-40°C to +125°C
Lead Temperature (soldering, 5sec.)	260°C
Storage Temperature (T_s)	-65°C to +150°C
ESD Rating ⁽⁴⁾	2kV

Operating Ratings ⁽²⁾

Supply voltage (V_{IN})	2.65V to 5.5V
Enable Input Voltage (V_{EN})	0V to V_{IN}
Junction Temperature (T_J)	-40°C to +125°C
Junction Thermal Resistance	
2mm x 2mm Thin MLF [®] 6 pin (θ_{JA})	93°C/W
TSOT-23-5 (θ_{JA})	235°C/W

Electrical Characteristics ⁽⁵⁾

$V_{IN} = V_{OUT} + 1.0V$; $C_{OUT} = 2.2\mu F$; $I_{OUT} = 100\mu A$; $T_J = 25^\circ C$, **bold** values indicate -40°C to +125°C, unless noted.

Parameter	Condition	Min	Typ	Max	Units
Output Voltage Accuracy	Variation from nominal V_{OUT} , $I_{OUT} = 100\mu A$ to 300mA	-2.0		+2.0	%
Line Regulation	$V_{IN} = V_{OUT} + 1V$ to 5.5V		0.02	0.3	%/V
Load Regulation ⁽⁶⁾	$I_{OUT} = 100\mu A$ to 300mA		0.1	0.5	%
Dropout Voltage	$I_{OUT} = 50mA$, $V_{OUT} > 2.8V$		20	35	mV
	$I_{OUT} = 150mA$, $V_{OUT} > 2.8V$		60	85	mV
	$I_{OUT} = 300mA$, $V_{OUT} > 2.8V$		120	170	mV
	$I_{OUT} = 50mA$, $V_{OUT} \leq 2.8V$		25	45	mV
	$I_{OUT} = 150mA$, $V_{OUT} \leq 2.8V$		75	110	mV
	$I_{OUT} = 300mA$, $V_{OUT} \leq 2.8V$		150	220	mV
Ground Pin Current ⁽⁷⁾	$I_{OUT} = 0$ to 300mA		90	150	μA
Ground Pin Current in Shutdown	$V_{EN} = 0V$		0.5	2	μA
Ripple Rejection	$f = 1kHz$; $C_{OUT} = 2.2\mu F$ ceramic; $C_{BYP} = 0.1\mu F$		80		dB
	$f = 10kHz$; $C_{OUT} = 2.2\mu F$ ceramic; $C_{BYP} = 0.1\mu F$		65		dB
Current Limit	$V_{OUT} = 0V$	350	600	900	mA
Output Voltage Noise	$C_{OUT} = 2.2\mu F$, $C_{BYP} = 0.1\mu F$, 10Hz to 100kHz		20		μV_{rms}
Turn-On Time	$C_{OUT} = 2.2\mu F$; $C_{BYP} = 0.1\mu F$; $I_{OUT} = 300mA$		30	150	μs
Enable Input Voltage	Logic Low			0.2	V
	Logic High	1.2			V
Enable Input Current	$V_{IL} \leq 0.2V$		0.01	1	μA
	$V_{IH} \geq 1.2V$		0.01	1	μA

Notes:

- Exceeding the absolute maximum rating may damage the device.
- The device is not guaranteed to function outside its operating rating.
- The maximum allowable power dissipation of any T_A (ambient temperature) is $P_{D(max)} = (T_{J(max)} - T_A) / \theta_{JA}$. Exceeding the maximum allowable power dissipation will result in excessive die temperature, and the regulator will go into thermal shutdown.
- Devices are ESD sensitive. Handling precautions recommended. Human body model, 1.5k Ω in series with 100pF.
- Specification for packaged product only.
- Regulation is measured at constant junction temperature using low duty cycle pulse testing, changes in output voltage due to heating effects are covered by the thermal regulation specification.
- Ground pin current is the regulator quiescent current. The total current drawn from the supply is the sum of the load current plus the ground pin current.

Typical Characteristics

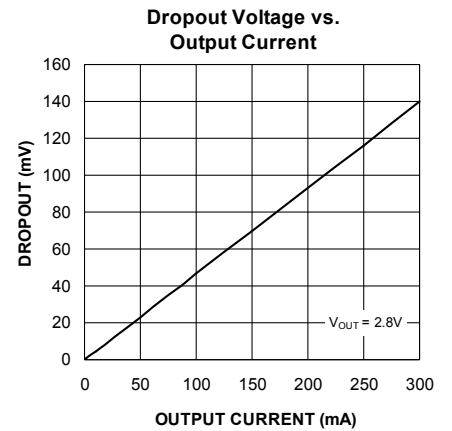
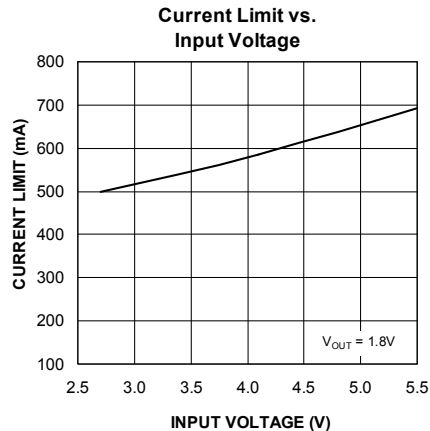
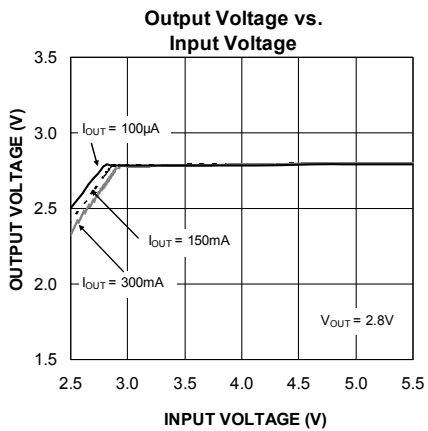
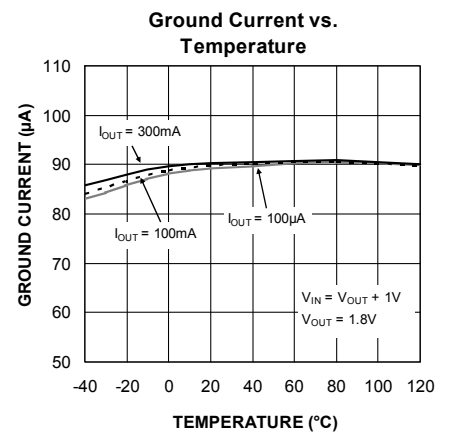
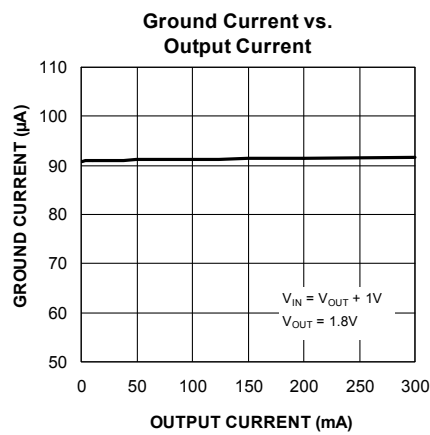
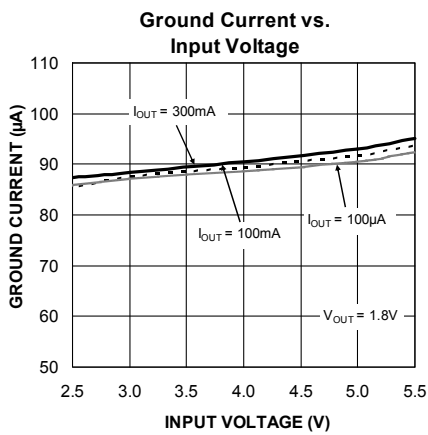
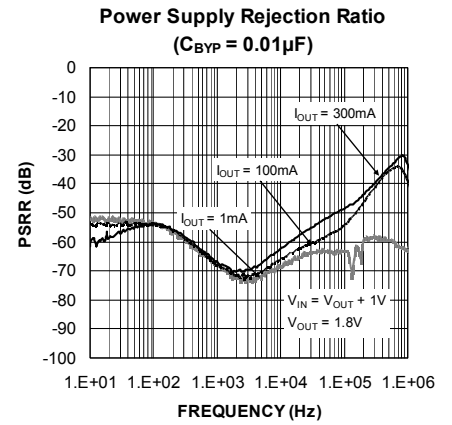
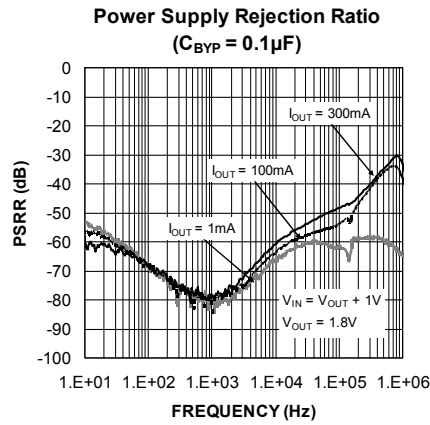
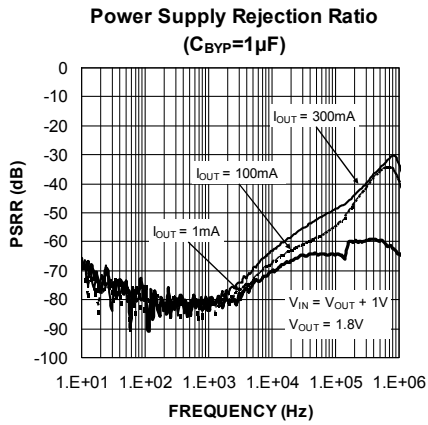

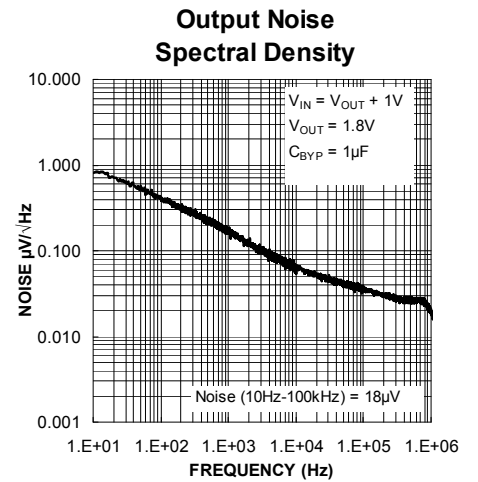
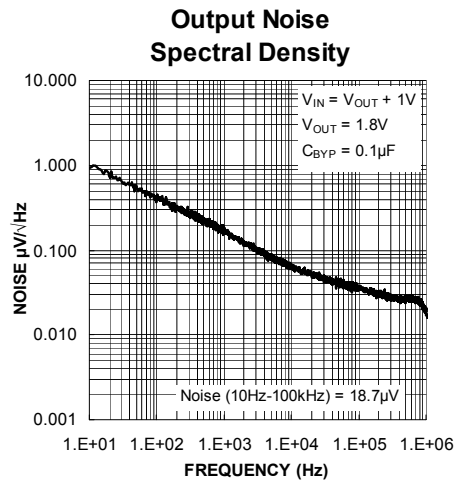
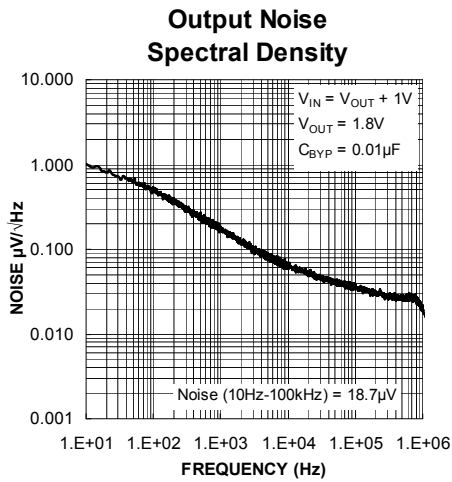
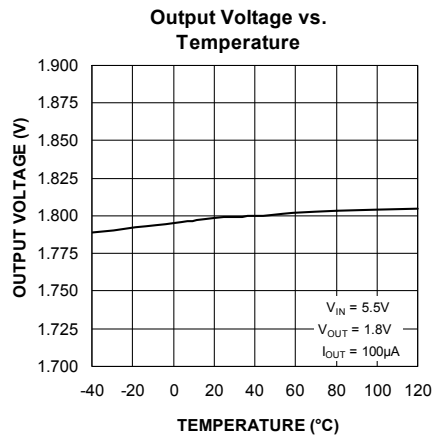
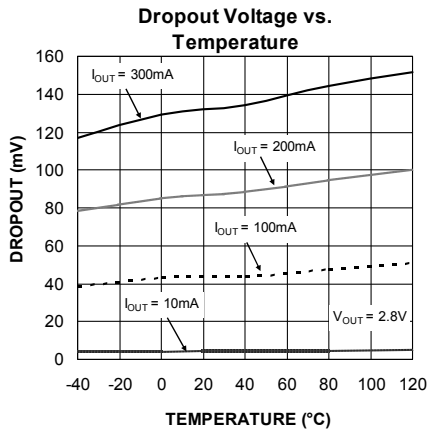

Functional Characteristics

Load Transient (10mA to 300mA)

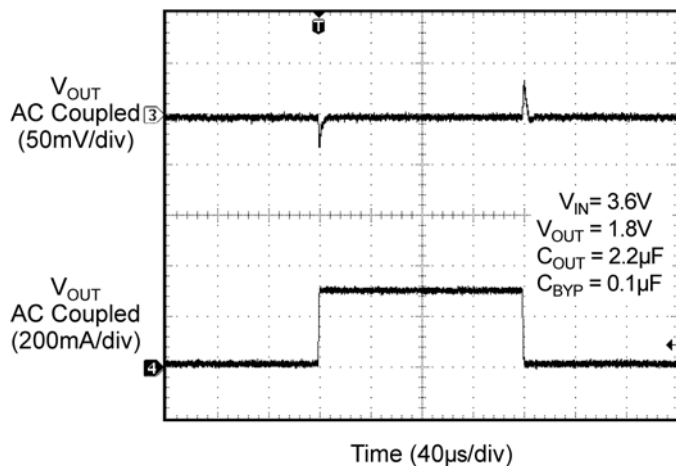

Line Transient (2.7V to 5.5V)

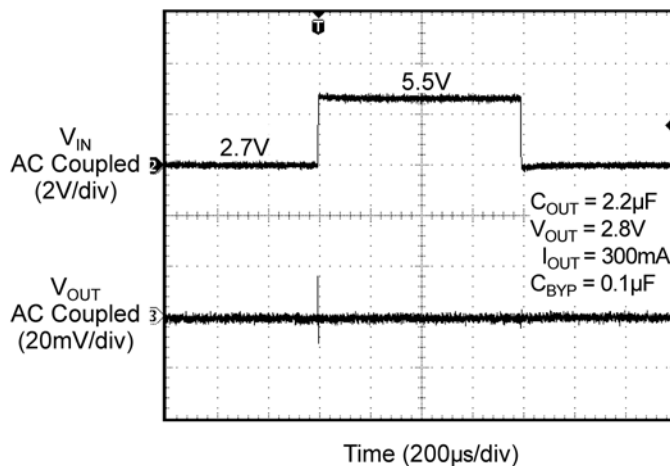

Startup

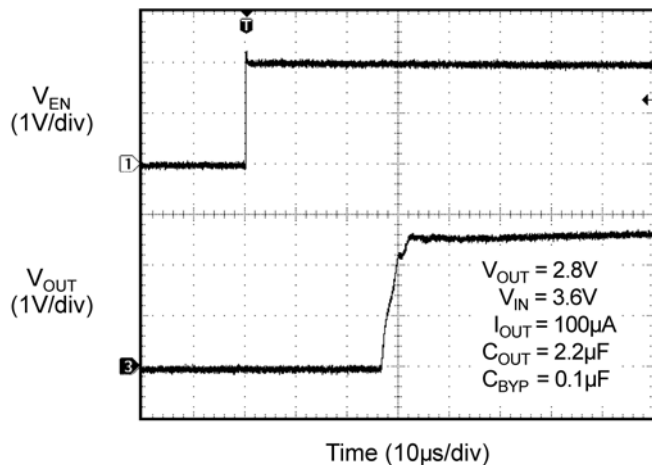

Shutdown

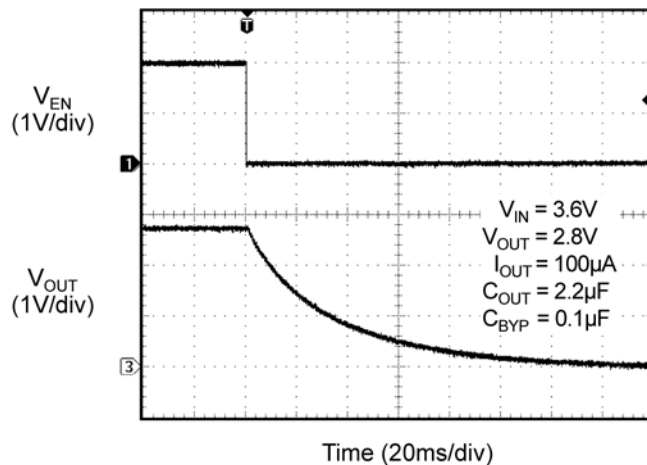

Functional Diagram

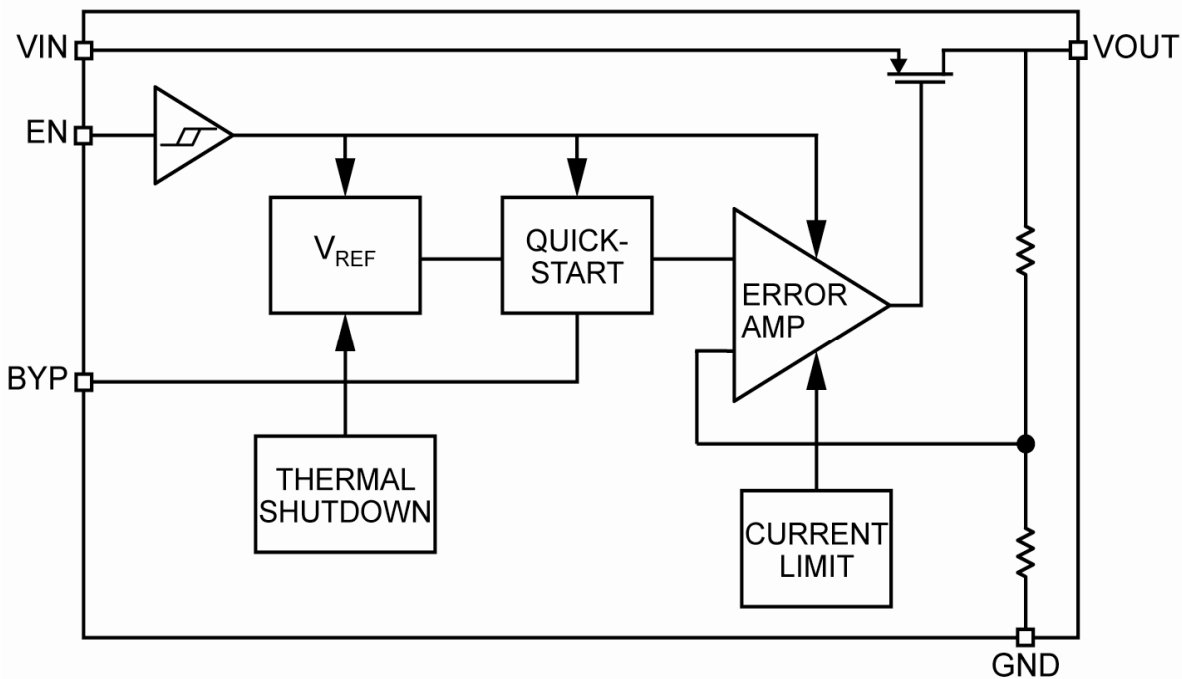

MIC5323 Block Diagram – Fixed

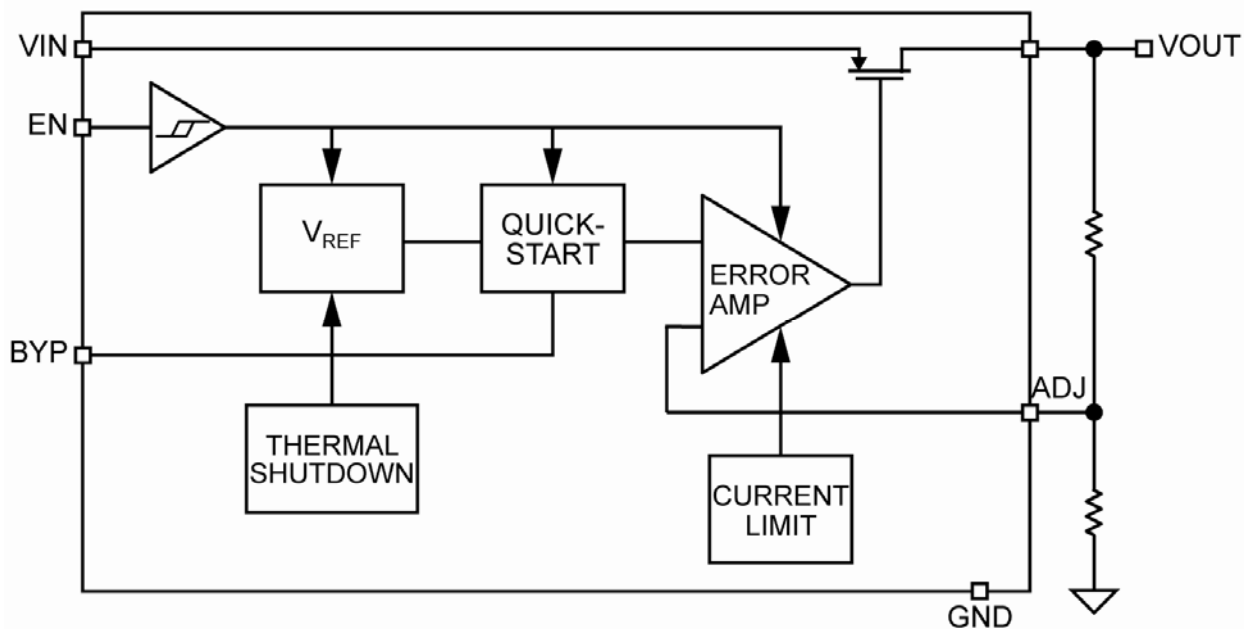

MIC5323 Block Diagram – Adjustable

Application Information

Enable/Shutdown

The MIC5323 comes with an active high enable pin that allows the regulator to be disabled. Forcing the enable pin low disables the regulator and sends it into a “zero” off mode current state. In this state, current consumed by the regulator goes nearly to zero. Forcing the enable pin high enables the output voltage. The active high enable pin uses CMOS technology, and the enable pin cannot be left floating; a floating enable pin may cause an indeterminate state on the output.

Input Capacitor

The MIC5323 is a high performance, high bandwidth device. Therefore, it requires a well-bypassed input supply for optimal performance. A 2.2μF capacitor is required from the input-to-ground to provide stability. Low ESR ceramic capacitors provide optimal performance using a minimum amount of space. Additional high frequency capacitors, such as small valued NPO dielectric type capacitors, help filter out high-frequency noise, and are a good practice in any RF based circuit.

Output Capacitor

The MIC5323 requires an output capacitor of 2.2μF or greater to maintain stability. The design is optimized for use with low ESR ceramic chip capacitors. High ESR capacitors may cause high frequency oscillation. The output capacitor can be increased, but performance has been optimized for a 2.2μF ceramic output capacitor, and it does not improve significantly with larger capacitance.

X7R/X5R dielectric type ceramic capacitors are recommended because of their temperature performance. X7R type capacitors change capacitance by 15% over their operating temperature range, making them the most stable type of ceramic capacitors. Z5U and Y5V dielectric capacitors change value by as much as 50% and 60%, respectively, over their operating temperature ranges. To use a ceramic chip capacitor with Y5V dielectric, the value must be much higher than an X7R ceramic capacitor to ensure the same minimum capacitance over the equivalent operating temperature range.

Bypass Capacitor

A capacitor can be placed from the noise bypass pin to ground to reduce output voltage noise. The capacitor bypasses the internal reference. A 0.1μF capacitor is recommended for applications that require low noise outputs. The bypass capacitor can be increased, further reducing noise and improving PSRR. Turn-on time increases slightly with respect to bypass capacitance. A unique, quick-start circuit allows the MIC5323 to drive a large capacitor on the bypass pin without significantly

slowing turn on time. Refer to the Typical Characteristics section for performance with different bypass capacitors.

No Load Stability

Unlike many other voltage regulators, the MIC5323 will remain stable and in regulation with no load. This is especially important in CMOS RAM keep alive applications.

Adjustable Regulator Application

Adjustable regulators use the ratio of two resistors to multiply the reference voltage to produce the desired output voltage. The MIC5323 can be adjusted from 1.25V to 5.5V by using two external resistors (Figure 1). The resistors set the output voltage based on the following equation:

$$V_{OUT} = V_{REF} \cdot \left(1 + \frac{R1}{R2} \right)$$

$$V_{REF} = 1.25V$$

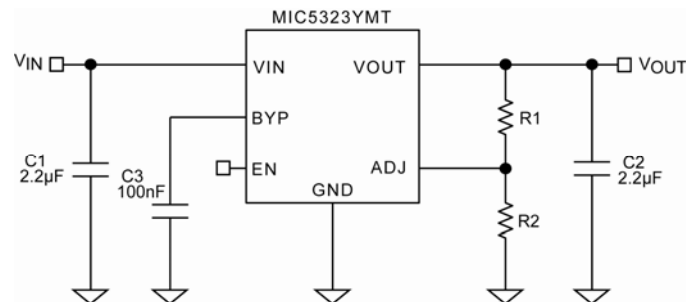

Figure 1. Adjustable Voltage Application

Thermal Considerations

The MIC5323 is designed to provide 300mA of continuous current in a very small package. Maximum ambient operating temperature can be calculated based on the output current and the voltage drop across the part. Given that the input voltage is 3.3V, the output voltage is 2.8V and the output current = 300mA.

The actual power dissipation of the regulator circuit can be determined using the equation:

$$P_D = (V_{IN} - V_{OUT}) I_{OUT} + V_{IN} I_{GND}$$

Because this device is CMOS and the ground current is typically $100\mu A$ over the load range, the power dissipation contributed by the ground current is <math>< 1\%</math> and can be ignored for this calculation.

$$P_D = (3.3V - 2.8V) \times 300mA$$

$$P_D = 0.15W$$

To determine the maximum ambient operating temperature of the package, use the junction-to-ambient thermal resistance of the device and the following basic equation:

$$P_{D(max)} = \left(\frac{T_{J(max)} - T_A}{\theta_{JA}} \right)$$

Where $T_{J(max)}$ is the maximum junction temperature, 125°C, and θ_{JA} represents the junction-to-ambient

thermal resistance, 93°C/W.

Substituting P_D for $P_{D(max)}$ and solving for the ambient operating temperature will give the maximum operating conditions for the regulator circuit consuming P_D watts. The maximum power dissipation must not be exceeded for proper operation.

For example, when operating the MIC5323-2.8YMT at an input voltage of 3.3V and 300mA load with a minimum footprint layout, the maximum ambient can be solved for as follows:

$$0.15W = \left(\frac{125^\circ C - T_A}{93^\circ C/W} \right)$$

$$T_A = 111^\circ C$$

Therefore, a 2.8V application at 300mA of output current can accept an ambient operating temperature of 111°C in a 6 pin 2mm x 2mm Thin MLF® package. For a full discussion of heat sinking and thermal effects on voltage regulators, refer to the “Regulator Thermals” section of *Micrel’s Designing with Low-Dropout Voltage Regulators* handbook. This information can be found on Micrel’s website at:

http://www.micrel.com/_PDF/other/LDOBk_ds.pdf

Typical Application Circuit (Fixed Output)

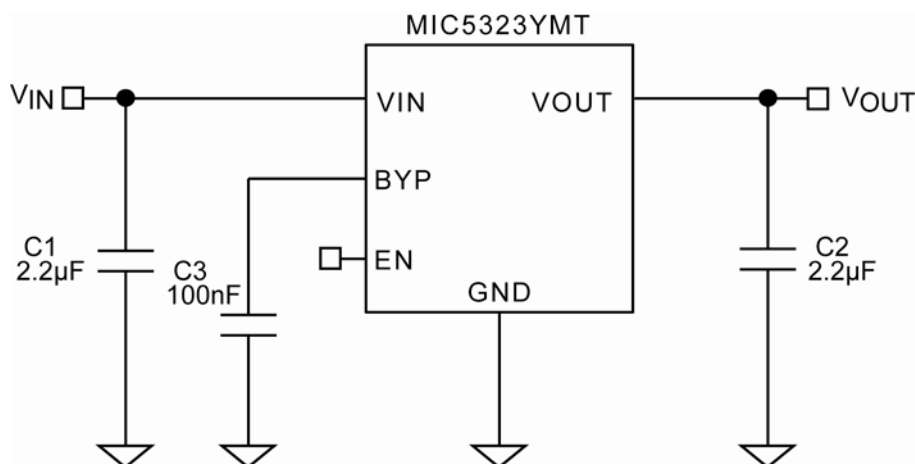

Bill of Materials

Item	Part Number	Manufacturer	Description	Qty.
C1	C1608X5R0J225K	TDK ⁽¹⁾	Ceramic Capacitor, 2.2µF, 6.3V, X5R, Size 0603	1
	GRM188R60J225KE19D	Murata ⁽²⁾		
C2	C1608X5R0J225K	TDK ⁽¹⁾		1
	GRM188R60J225KE19D	Murata ⁽²⁾		
C3	CL10B104KB8NNN	Samsung ⁽³⁾	Ceramic Capacitor, 100nF, 50V, X5R, Size 0603	1
U1	MIC5323YMT	Micrel, Inc. ⁽⁴⁾	300mA Low Noise Ultra Low Dropout LDO	1

Notes:

1. TDK: www.tdk.com
2. Murata: www.murata.com
3. Samsung: www.samsungsem.com
4. Micrel, Inc.: www.micrel.com

Typical Application Circuit (Adjustable Output)

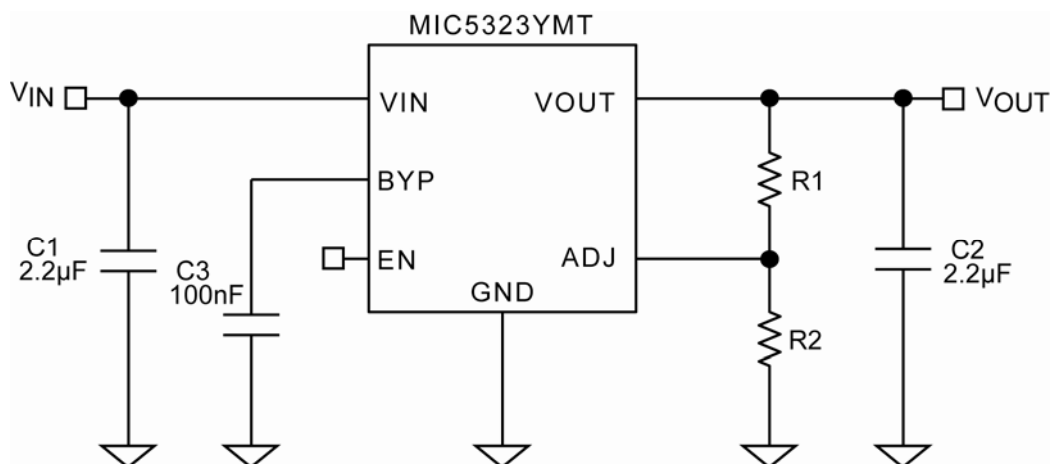

Bill of Materials

Item	Part Number	Manufacturer	Description	Qty.
C1	C1608X5R0J225K	TDK ⁽¹⁾	Ceramic Capacitor, 2.2µF, 6.3V, X5R, Size 0603	1
	GRM188R60J225KE19D	Murata ⁽²⁾		
C2	C1608X5R0J225K	TDK ⁽¹⁾		1
	GRM188R60J225KE19D	Murata ⁽²⁾		
C3	CL10B104KB8NNN	Samsung ⁽³⁾	Ceramic Capacitor, 100nF, 50V, X7R, Size 0603	1
R1	CRCW060312K1FKEA	Vishay ⁽⁴⁾	Resistor, 10kΩ, 1%, 1/16W, Size 0603	1
R2	CRCW060312K1FKEA	Vishay ⁽⁴⁾	Resistor, 10kΩ, 1%, 1/16W, Size 0603	1
U1	MIC5323YMT	Micrel, Inc. ⁽⁵⁾	300mA Low Noise Ultra Low Dropout LDO	1

Notes:

1. TDK: www.tdk.com
2. Murata: www.murata.com
3. Samsung: www.samsungsem.com
4. Vishay: www.vishay.com
5. Micrel, Inc.: www.micrel.com

Layout Recommendations

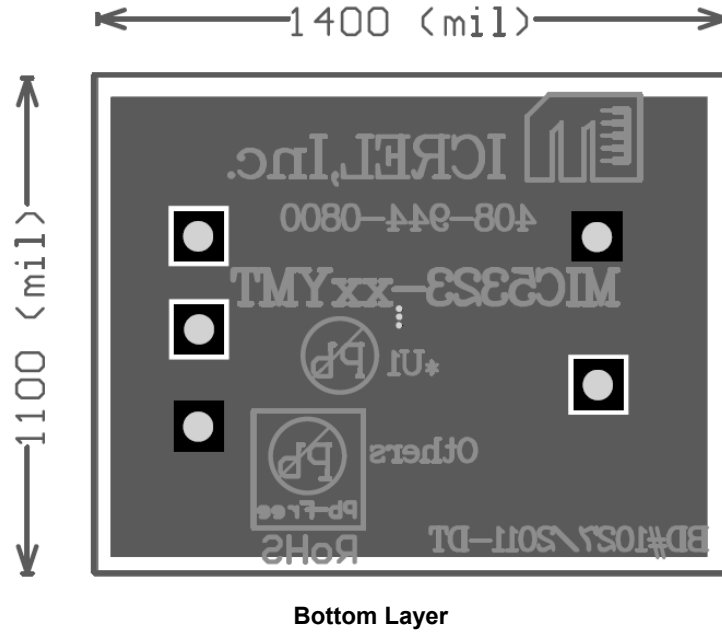
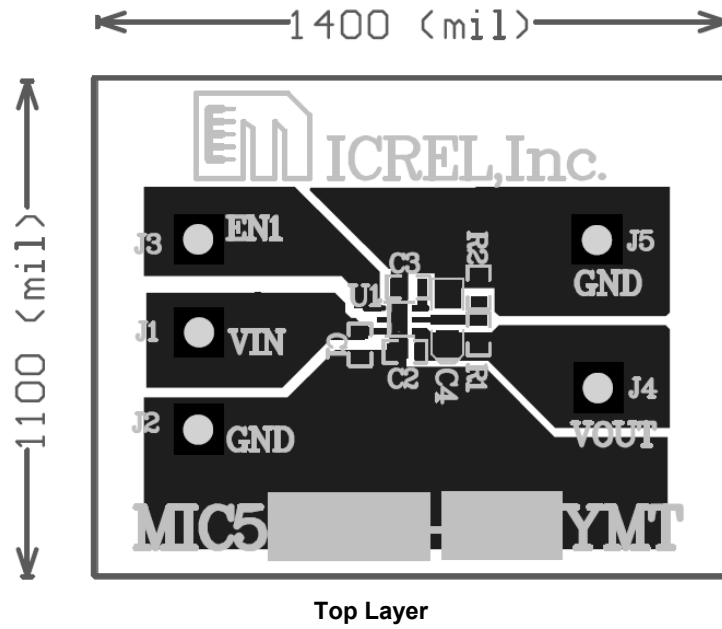

Package Information

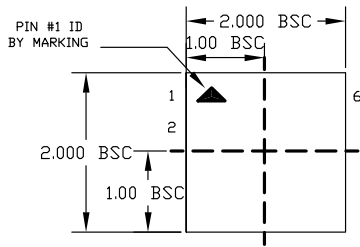

TOP VIEW

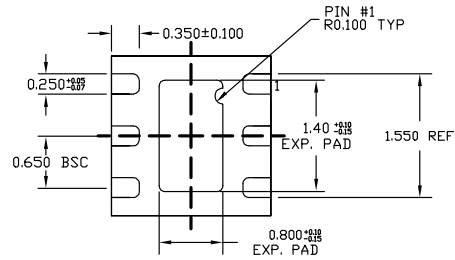

BOTTOM VIEW

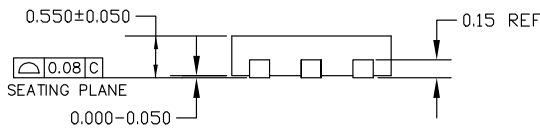

SIDE VIEW

NOTE:

1. ALL DIMENSIONS ARE IN MILLIMETERS.
2. MAX. PACKAGE WARPAGE IS 0.08 mm.
3. MAXIMUM ALLOWABLE BURRS IS 0.076 mm IN ALL DIRECTIONS.
4. PIN #1 ID ON TOP WILL BE LASER MARKED.

6-Pin 2mm x 2mm Thin MLF® (MT)

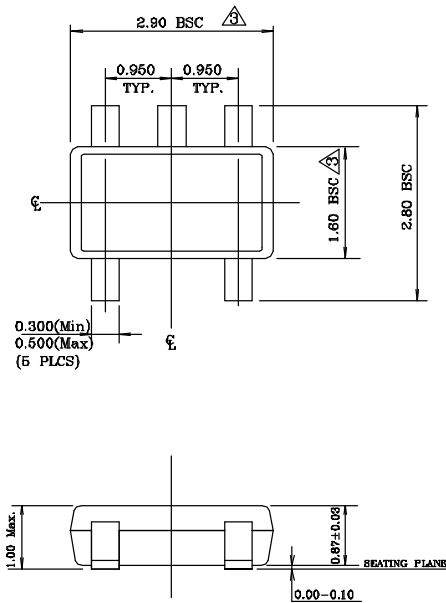

NOTE:

1. Dimensions and tolerances are as per ANSI Y14.5M, 1994.
2. Die is facing up for mold. Die is facing down for trim/form, ie. reverse trim/form.
- △ Dimensions are exclusive of mold flash and gate burr.
4. The footlength measuring is based on the gauge plane method.
5. All specification comply to Jedec Spec M0193 Issue C.
6. All dimensions are in millimeters.

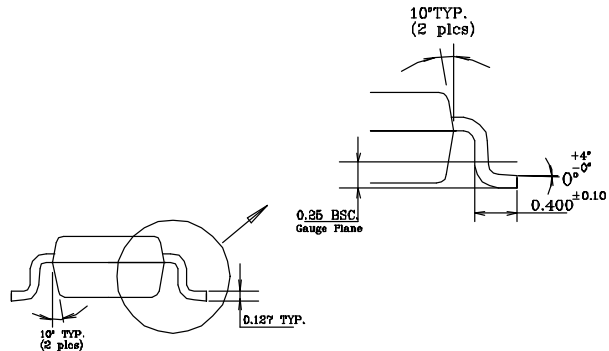

5-Pin TSOT-23 (D5)

MICREL, INC. 2180 FORTUNE DRIVE SAN JOSE, CA 95131 USA
TEL +1 (408) 944-0800 FAX +1 (408) 474-1000 WEB <http://www.micrel.com>

Micrel makes no representations or warranties with respect to the accuracy or completeness of the information furnished in this data sheet. This information is not intended as a warranty and Micrel does not assume responsibility for its use. Micrel reserves the right to change circuitry, specifications and descriptions at any time without notice. No license, whether express, implied, arising by estoppel or otherwise, to any intellectual property rights is granted by this document. Except as provided in Micrel's terms and conditions of sale for such products, Micrel assumes no liability whatsoever, and Micrel disclaims any express or implied warranty relating to the sale and/or use of Micrel products including liability or warranties relating to fitness for a particular purpose, merchantability, or infringement of any patent, copyright or other intellectual property right.

Micrel Products are not designed or authorized for use as components in life support appliances, devices or systems where malfunction of a product can reasonably be expected to result in personal injury. Life support devices or systems are devices or systems that (a) are intended for surgical implant into the body or (b) support or sustain life, and whose failure to perform can be reasonably expected to result in a significant injury to the user. A Purchaser's use or sale of Micrel Products for use in life support appliances, devices or systems is a Purchaser's own risk and Purchaser agrees to fully indemnify Micrel for any damages resulting from such use or sale.

© 2011 Micrel, Incorporated.